



U.S. Department
of Transportation
**National Highway
Traffic Safety
Administration**

MAR 26 2008

1200 New Jersey Avenue SE
Washington, DC 20590

CERTIFIED MAIL
RETURN RECEIPT REQUESTED

Mr. Roger Hagie
Director, Public Affairs
Kawasaki Motors Corp., U.S.A.
9950 Jeronimo Road
Irvine, CA 92618

NVS-214jry
PE08-021

Dear Mr. Hagie:

As you are aware, we recently opened this investigation based on five Vehicle Owner Questionnaires (complaints), a number of EWR field reports, and discussions on web forums alleging frame cross member separations due to weld failures involving some MY 2006-7 Kawasaki ZX14 model motorcycles.

To assess whether these reports indicate the existence of a safety defect trend, we are opening this PE and request the following information. Unless otherwise stated in the text, the following definitions apply to this information request:

Subject Vehicles: All MY 2006-7 ZX14 model motorcycles produced for sale in the United States.

Subject Component: lower-most frame crossmember.

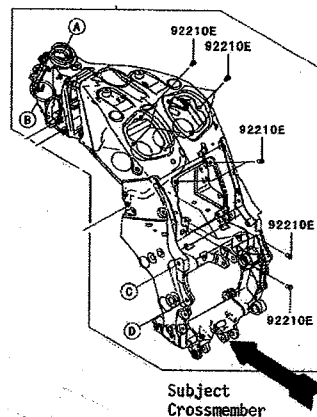

Alleged defect: subject component structural failure (of any kind) and/or its separation (full or partial) from the frame.

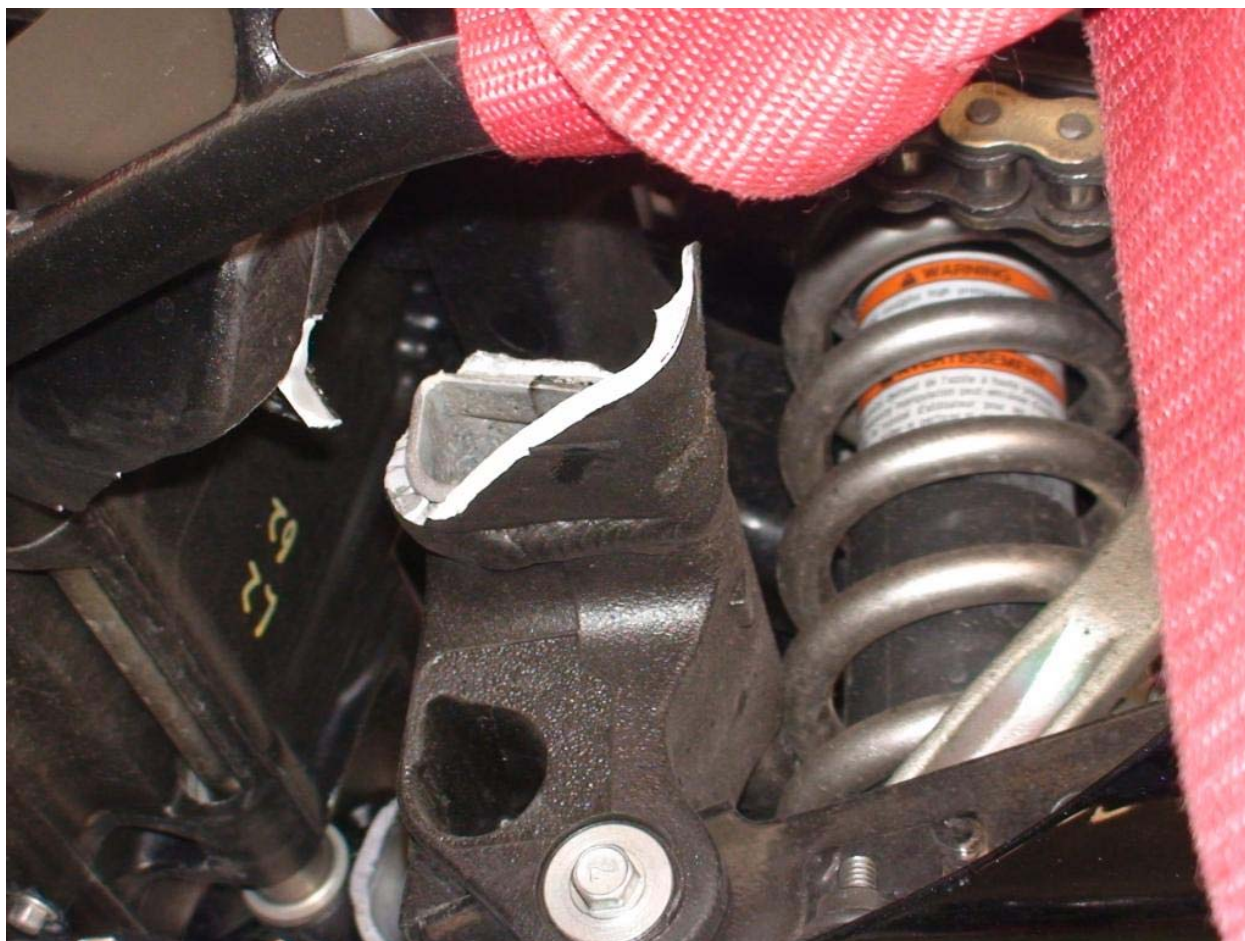

Kawasaki: Kawasaki Motors Corp., U.S.A., its parent company, and all of its past and present officers and employees, whether assigned to its principal offices or any of its field or other locations, including all of its divisions, subsidiaries (whether or not incorporated) and affiliated enterprises and all of their headquarters, regional, zone and other offices and their employees, and all agents, contractors, consultants, attorneys and law firms and other persons engaged directly or indirectly (e.g., employee of a consultant) by or under the control of Kawasaki (including all business units and persons previously referred to), who were involved in any way with any of the following related to the alleged defect:

- a. Design, engineering, analysis, modification, or production (e.g., quality control);
- b. Testing, assessment, or evaluation;
- c. Consideration, or recognition of potential or actual defects, reporting, record-keeping and information management, (e.g., complaints, field reports, warranty information, part sales), analysis, claims, or lawsuits; or
- d. Communication to, from or intended for zone representatives, field quality engineers, assembly plant engineers, component suppliers, assembly wholesalers, retailers, or other field locations, including but not limited to people who have the capacity to obtain information from wholesalers or retailers, all officers, employees, agents, contractors, and consultants of Kawasaki, whether assigned to its principal office or to any of its field locations, and all records or files maintained by the company either in hard copy form or in electronic storage media.

Document: "Document(s)" is used in the broadest sense of the word and shall mean all original written, printed, typed, recorded, or graphic matter whatsoever, however produced or reproduced, of every kind, nature, and description, and all non-identical copies of both sides thereof, including, but not limited to, papers, letters, memoranda, correspondence, communications, electronic mail (e-mail) messages (existing in hard copy and/or in electronic storage), faxes, mailgrams, telegrams, cables, telex messages, notes, annotations, working papers, drafts, minutes, records, audio and video recordings, data, databases, other information bases, summaries, charts, tables, graphics, other visual displays, photographs, statements, interviews, opinions, reports, newspaper articles, studies, analyses, evaluations, interpretations, contracts, agreements, jottings, agendas, bulletins, notices, announcements, instructions, blueprints, drawings, as-builts, changes, manuals, publications, work schedules, journals, statistical data, desk, portable and computer calendars, appointment books, diaries, travel reports, lists, tabulations, computer printouts, data processing program libraries, data processing inputs and outputs, microfilms, microfiches, statements for services, resolutions, financial statements, governmental records, business records, personnel records, work orders, pleadings, discovery in any form, affidavits, motions, responses to discovery, all transcripts, administrative filings and all mechanical, magnetic, photographic and electronic records or recordings of any kind, including any storage media associated with computers, including, but not limited to, information on hard drives, floppy disks, backup tapes, and zip drives, electronic communications, including but not limited to, the Internet and shall include any drafts or revisions pertaining to any of the foregoing, all other things similar to any of the foregoing, however denominated by Kawasaki, any other data compilations from which information can be obtained, translated if necessary, into a usable form and any other documents. For purposes of this request, any document containing any note, comment, addition, deletion, insertion, annotation, or otherwise comprises a non-identical copy of another document shall be treated as a separate document subject to production. In all cases where original and any non-identical copies are not available, "document(s)" also means any identical copies of the original and all non-identical copies thereof. Any document, record, graph, chart, film or photograph originally produced in color must be provided in color. Furnish all documents whether verified by Kawasaki or not. If a document is not in the English language, provide both the original document and an English translation of the document.

Other Terms: To the extent that they are used in these information requests, the terms "claim," "consumer complaint," "dealer field report," "field report," "fire," "fleet," "good will," "make," "model," "model year," "notice," "property damage," "property damage claim," "rollover," "type," "warranty," "warranty adjustment," and "warranty claim," whether used in singular or in plural form, have the same meaning as found in 49 CFR 579.4.

In order for my staff to evaluate the alleged defect, certain information is required. Pursuant to 49 U.S.C. § 30166, please provide numbered responses to the following information requests. Insofar as Kawasaki has previously provided a document to ODI, Kawasaki may produce it again or identify the document, the document submission to ODI in which it was included and the precise location in that submission where the document is located. When documents are produced, the documents shall be produced in an identified, organized manner that corresponds with the organization of this information request letter (including all individual requests and

subparts). When documents are produced and the documents would not, standing alone, be self-explanatory, the production of documents shall be supplemented and accompanied by explanation.

Please repeat the applicable request verbatim above each response. After Kawasaki's response to each request, identify the source of the information and indicate the last date the information was gathered.

1. State, by model and model year, the number of subject vehicles Kawasaki has manufactured for sale or lease in the United States. Separately, for each subject vehicle manufactured to date by Kawasaki, state the following:
 - a. Vehicle identification number (VIN);
 - b. Model Year;
 - c. Model;
 - d. Date of manufacture;
 - e. Warranty coverage start date;
 - f. Original purchaser first and last name; and
 - g. The selling dealer Kawasaki identification number (i.e., 239224, 241415, etc.).

Provide the table in Microsoft Access 2000, or a compatible format, entitled "PRODUCTION DATA." See the attached CD-ROM, titled "PE08-021 IR Attachments", for pre-formatted template illustrating the requested information format.

2. State the number of each of the following, received by Kawasaki, or of which Kawasaki is otherwise aware, which relate to, or may relate to, the alleged defect:
 - a. Consumer complaints;
 - b. Field reports, including dealer field reports;
 - c. Reports involving a crash, injury, or fatality, based on claims against the manufacturer involving a death or injury and/or notices received by the manufacturer alleging or proving that a death or injury was caused by a possible defect in a subject vehicle.
 - d. Property damage claims;
 - e. Third-party arbitration proceedings where Kawasaki is or was a party to the arbitration; and
 - f. Lawsuits, both pending and closed, where Kawasaki is or was a defendant or codefendant.

For subparts "a" through "d," state the total number of each item (e.g., consumer complaints, field reports, etc.) separately. Multiple incidents involving the same vehicle are to be counted separately. Multiple reports of the same incident are also to be counted separately (i.e., a consumer complaint and a field report involving the same incident in which a crash occurred are to be counted as a crash report, a field report and a consumer complaint).

In addition, for items "c" through "f," provide a summary description of the alleged problem and causal and contributing factors and Kawasaki's assessment of the problem, with a summary of the significant underlying facts and evidence. For items "e" and "f," identify the

parties to the action, as well as the caption, court, docket number, and date on which the complaint or other document initiating the action was filed.

3. Separately, for each item (complaint, report, claim, notice, or matter) within the scope of your response to Request No. 2, state the following information:
 - a. Kawasaki's file number or other identifier used;
 - b. The category of the item, as identified in Request No. 2 (i.e., consumer complaint, field report, etc.);
 - c. Vehicle owner name, address, and telephone number;
 - d. Vehicle's VIN;
 - e. Vehicle model year;
 - f. Vehicle's mileage at time of incident;
 - g. Incident date;
 - h. Report or claim date;
 - i. Whether a crash is alleged;
 - j. Whether property damage is alleged;
 - k. Number of alleged injuries, if any; and
 - l. Number of alleged fatalities, if any.

Provide this information in Microsoft Access 2000, or a compatible format, entitled "COMPLAINT DATA." See the attached CD-ROM, titled "PE08-021 IR Attachments", for a pre-formatted template illustrating the requested information format.

4. Produce copies of all documents related to each item within the scope of Request No. 2. Organize the documents separately by category (i.e., consumer complaints, field reports, etc.) and describe the method Kawasaki used for organizing the documents.
5. State, by model and model year, a total count for all of the following categories of claims, collectively, that have been paid by Kawasaki to date that relate to, or may relate to, the alleged defect: warranty claims; extended warranty claims; claims for good will services that were provided; field, zone, or similar adjustments and reimbursements; and warranty claims or repairs made in accordance with a procedure specified in a technical service bulletin or customer satisfaction campaign.

Separately, for each such claim, state the following information:

- a. Kawasaki's claim number;
- b. Vehicle owner and telephone number;
- c. VIN;
- d. Repair date;
- e. Vehicle mileage at time of repair;
- f. Repairing dealer's Kawasaki identification number;
- g. Labor operation number;
- h. Problem code;
- i. Replacement part number(s) and description(s);
- j. Concern stated by customer; and
- k. Comment, if any, by dealer/technician relating to claim and/or repair.

Provide this information in Microsoft Access 2000, or a compatible format, entitled "WARRANTY DATA." See the attached CD-ROM, titled "PE08-021 IR Attachments", for a pre-formatted template illustrating the requested information format.

In addition to the total counts requested above, provide Kawasaki's assessment, by model and model year, of the number of claims within each of the counts given that relate to, or may relate to, the alleged defect.

6. Describe in detail the search criteria used by Kawasaki to identify the claims identified in response to Request No. 5, including the labor operations, problem codes, part numbers and any other pertinent parameters used. Provide a list of all labor operations, labor operation descriptions, problem codes, and problem code descriptions applicable to the alleged defect in the subject vehicles. State, by make and model year, the terms of the new vehicle warranty coverage offered by Kawasaki on the subject vehicles (i.e., the number of months and mileage for which coverage is provided and the vehicle systems that are covered). Describe any extended warranty coverage option(s) that Kawasaki offered for the subject vehicles and state by option, model, and model year, the number of vehicles that are covered under each such extended warranty.
7. Produce copies of all service, warranty, and other documents that relate to, or may relate to, the alleged defect that Kawasaki has issued to any dealers, regional or zone offices, field offices, fleet purchasers, or other entities. This includes, but is not limited to, bulletins, advisories, informational documents, training documents, or other documents or communications, with the exception of standard shop manuals. Also include the latest draft copy of any communication that Kawasaki is planning to issue within the next 120 days.
8. Describe all assessments, analyses, tests, test results, studies, surveys, simulations, investigations, inquiries and/or evaluations (collectively, "actions") that relate to, or may relate to, the alleged defect that have been conducted, are being conducted, are planned, or are being planned by, or for, Kawasaki. For each such action, provide the following information:
 - a. Action title or identifier;
 - b. The actual or planned start date;
 - c. The actual or expected end date;
 - d. Brief summary of the subject and objective of the action;
 - e. Engineering group(s)/supplier(s) responsible for designing and for conducting the action; and
 - f. A brief summary of the findings and/or conclusions resulting from the action.

For each action identified, provide copies of all documents related to the action, regardless of whether the documents are in interim, draft, or final form. Organize the documents chronologically by action.

9. Describe all modifications or changes made by, or on behalf of, Kawasaki in the design, material composition, manufacture, quality control, supply, or installation of the subject

component, from the start of production to date, which relate to, or may relate to, the alleged defect. For each such modification or change, provide the following information:

- a. The date or approximate date on which the modification or change was incorporated into vehicle production;
 - b. A detailed description of the modification or change;
 - c. The reason(s) for the modification or change;
 - d. The part numbers (service and engineering) of the original component;
 - e. The part number (service and engineering) of the modified component;
 - f. Whether the original unmodified component was withdrawn from production and/or sale, and if so, when;
 - g. When the modified component was made available as a service component; and
 - h. Whether the modified component can be interchanged with earlier production components.
10. Also, provide the above information for any modification or change that Kawasaki is aware of which may be incorporated into vehicle production within the next 120 days.
11. State the number of subject frames Kawasaki has sold by component name, part number (both service and engineering/production), and model year of the subject vehicle in which it is used and month/year of sale (including the cut-off date for sales, if applicable).
12. Provide a listing, ordered by Kawasaki dealer number (i.e., 1381, 1814, etc.), of all Kawasaki motorcycle dealers in the United States and its territories. Please include the dealer name (including, where applicable, its DBA), street address (including city, state, and zip code), contact phone number, and Kawasaki dealer number.
13. Furnish Kawasaki's assessment of the alleged defect in the subject vehicle, including:
- a. The causal or contributory factor(s);
 - b. The failure mechanism(s);
 - c. The failure mode(s);
 - d. The risk to motor vehicle safety that it poses;
 - e. What warnings, if any, the operator and the other persons both inside and outside the vehicle would have that the alleged defect was occurring or subject component was malfunctioning;
 - f. The EWR field reports included with this inquiry; and
 - g. The ODI owner reports included with this inquiry.

This letter is being sent to Kawasaki pursuant to 49 U.S.C. § 30166, which authorizes NHTSA to conduct any investigation that may be necessary to enforce Chapter 301 of Title 49 and to request reports and the production of things. It constitutes a new request for information. Kawasaki's failure to respond promptly and fully to this letter could subject Kawasaki to civil penalties pursuant to 49 U.S.C. § 30165 or lead to an action for injunctive relief pursuant to 49 U.S.C. § 30163. (Other remedies and sanctions are available as well.) Please note that maximum civil penalties under 49 U.S.C. § 30165 have increased as a result of the recent enactment of the Transportation Recall Enhancement, Accountability, and Documentation (TREAD) Act, Public Law No. 106-414 (signed November 1, 2000). Section 5(a) of the

TREAD Act, codified at 49 U.S.C. § 30165(b), provides for civil penalties of up to \$6,000 per day, with a maximum of \$16,375,000 for a related series of violations, for failing or refusing to perform an act required under 49 U.S.C. § 30166. See 49 CFR 578.6 (as amended by 71 Fed. Reg. 28279 (May 16, 2006)). This includes failing to respond to ODI information requests.

If Kawasaki cannot respond to any specific request or subpart(s) thereof, please state the reason why it is unable to do so. If on the basis of attorney-client, attorney work product, or other privilege, Kawasaki does not submit one or more requested documents or items of information in response to this information request, Kawasaki must provide a privilege log identifying each document or item withheld, and stating the date, subject or title, the name and position of the person(s) from, and the person(s) to whom it was sent, and the name and position of any other recipient (to include all carbon copies or blind carbon copies), the nature of that information or material, and the basis for the claim of privilege and why that privilege applies.

Kawasaki's response to this letter, in duplicate, together with a copy of any confidentiality request, must be submitted to this office by May 9, 2008. **All business confidential information must be submitted directly to the Office of Chief Counsel as described in this and the following two paragraphs and should not be sent to this office.** In addition do not submit any business confidential information in the body of the letter submitted to this office. Please refer to PE08-021 in Kawasaki's response to this letter and in any confidentiality request submitted to the Office of Chief Counsel. If Kawasaki finds that it is unable to provide all of the information requested within the time allotted, it must request an extension from me at (202) 366-4933 no later than five business days before the response due date. If Kawasaki is unable to provide all of the information requested by the original deadline, it must submit a partial response by the original deadline with whatever information Kawasaki then has available, even if an extension has been granted.

If Kawasaki claims that any of the information or documents provided in response to this information request constitute confidential commercial material within the meaning of 5 U.S.C. § 552(b)(4), or are protected from disclosure pursuant to 18 U.S.C. § 1905, Kawasaki must submit supporting information together with the materials that are the subject of the confidentiality request, in accordance with 49 CFR Part 512, as amended (69 Fed. Reg. 21409 et seq; April 21, 2004), to the Office of Chief Counsel (NCC-110), National Highway Traffic Safety Administration, Room W41-227, 1200 New Jersey Avenue SE, Washington, D.C. 20590. Kawasaki is required to **submit two copies of the documents containing allegedly confidential information (except only one copy of blueprints) and one copy of the documents from which information claimed to be confidential has been deleted.** Please remember that the word "CONFIDENTIAL" must appear at the top of each page containing information claimed to be confidential, and the information must be clearly identified in accordance with 5 U.S.C. § 512.6.

If your request for confidentiality includes material provided in electronic format (on a CD-ROM, for example), your request and associated submission must conform to the new requirements in NHTSA's Confidential Business Information Rule regarding submissions in electronic formats (49 CFR 512.6(c)). For more information regarding this requirement, see Federal Register, volume 72, page 59434 (October 19, 2007).

Please send email notification to Bob Young (Robert.young@dot.gov) and to ODI_IRresponse@dot.gov when Kawasaki sends its response to this office and indicate whether there is confidential information as part of its response.

If you have any technical questions concerning this matter, please call Mr. Young at (202) 366-4806.

Sincerely,

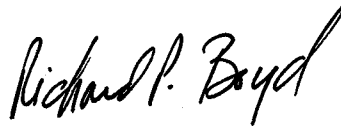
A handwritten signature in black ink that reads "Richard P. Boyd". The signature is written in a cursive style with a large, prominent "R" and "B".

Richard P. Boyd, Chief
Medium Heavy Duty Division
Office of Defects Investigation

Attachments – “PE08-021 CD-Rom”