

MPS Horn Button – Air Shifter Control Harness Installation Instructions

The MPS Horn Button – Air Shifter Control Harness will work on any bike with a horn. This time saving device makes it super easy to wire your horn/shifter switch.

Mount The Horn-Shifter Control Box -

Find a convenient spot to mount the horn – shifter switch box and secure it with the double sided tape.

Wire The Horns - Locate the horn(s). Carefully route the two yellow wires and the two green wires to the horn. Unplug the two wire leads with female spade connectors from the male spade terminal on the horn(s). Cut the two yellow wires to length and install two male spade connectors provided. Plug the two yellow wire leads into the factory horn harness female spade terminals. It doesn't matter which one of the yellows goes to each female, just one to each. Cut the two green wires to length and install two female spade connectors provided. Plug the two green wire leads into the two male spade terminals on the horn. It doesn't matter which one of the greens goes to which, just one to each. If you have a two horn system you won't use the two wire leads that connected to horn number two. Tape these up and tuck out of the way so they won't be damaged or shorted. If you still want to use horn number two you can wire jumpers from horn number one to horn number two. Most people simply remove them.



Wire Power & Grounds – The red wire will need to have a switched 12 volt power supply connected to it. You can usually find this at the on-off rocker switch on the handlebars or an auxiliary terminal on the fuse block. Consult your individual shop manual for wiring diagram. The black wire is a ground. You can use the ring connector provided and connect it to the battery negative (preferred) or and good ground.

Wire Blue Activation Wire - The blue wire is wired to the air shifter components. The blue wire outputs a ground signal when the control switch is set to the air shift position and the horn button is depressed. This will activate your electric air valve and your Electronic Engine Kill. The diagram below shows all wire connections.

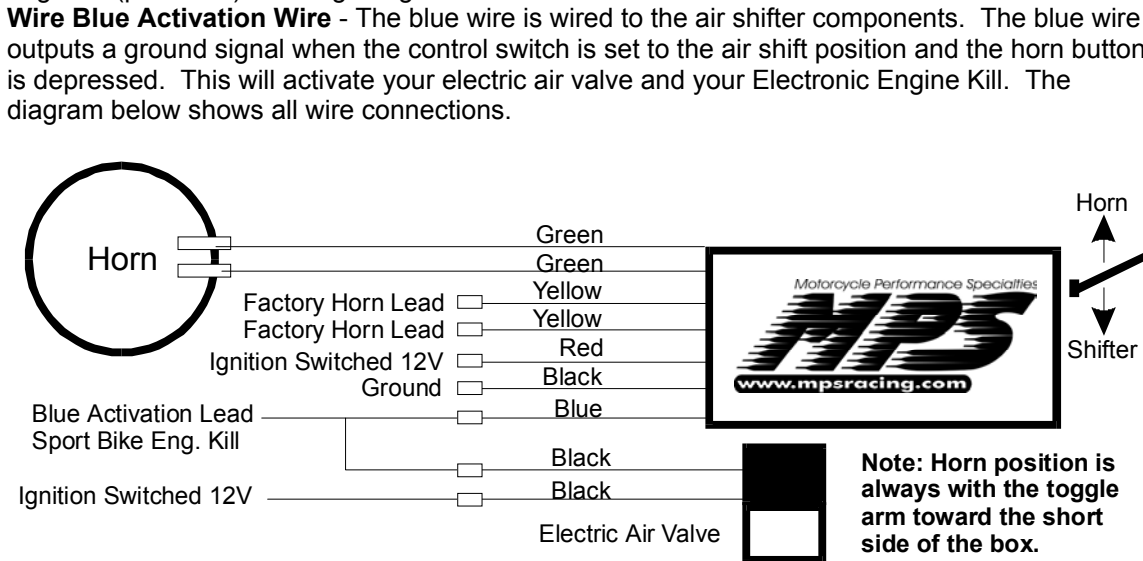

If you have any more questions we have a Frequently Asked Questions page at our web site as well as the telephone tech support. Thank you for your purchase of this MPS product. All products sold by MPS are for use at closed course competition events and not for use on public streets or highways.