



2005 CB900F SET-UP INSTRUCTIONS



**Set-up and pre-delivery service
must be performed by an authorized
Honda motorcycle dealer.**

IMPORTANCE OF PROPER SET-UP AND PRE-DELIVERY SERVICE

FOR YOUR CUSTOMER'S SAFETY

Proper set-up and pre-delivery service are essential to rider safety and the reliability of the machine. Any error or oversight made by the technician assembling and servicing a new machine can result in faulty operation, damage to the machine, or injury to the rider.

WARNING

Improper set-up or pre-delivery service can create an unsafe condition that can cause your customer to be seriously hurt or killed.

Follow the procedures and precautions in this manual and the service manual carefully.

FOR YOUR SAFETY

Some of the most important safety precautions are given below. However, we cannot warn you of every conceivable hazard that can arise in performing set-up and pre-delivery service. Only you can decide whether or not you should perform a given task.

WARNING

Failure to properly follow instructions and precautions can cause you to be seriously hurt or killed.

Follow the procedures and precautions in this manual carefully.

IMPORTANT SAFETY PRECAUTIONS

Make sure you have a clear understanding of all basic shop safety practices and that you are wearing appropriate clothing and safety equipment. When performing the set-up or pre-delivery service, be especially careful of the following:

- Read the instructions before you begin, and make sure you have the tools and skills required to perform the tasks safely.
- To prevent the machine from falling on you, park it on a firm, level surface, using the proper stand(s) to provide firm support.

Make sure the engine is off before you begin any servicing procedures. This will help eliminate several potential hazards:

- **Carbon monoxide poisoning from engine exhaust**—be sure there is adequate ventilation whenever you run the engine.
- **Burns from hot parts**—let the engine and exhaust system cool before touching.
- **Injury from moving parts**—do not run the engine unless the instruction tells you to do so. Even then, keep your hands, fingers, and clothing away.

To reduce the possibility of a fire or explosion, be careful when working around gasoline or batteries. Use only a nonflammable solvent, not gasoline, to clean parts. Keep all cigarettes, sparks and flames away from the battery and all fuel-related parts.

2005 CB900F

How To Use This Manual

Follow the complete sequence of steps as shown. Do not short-cut any steps. The sequence has been established to ensure the unit is properly assembled.

The individual steps are composed of three components:

- Sub-heading—The large sub-headings are a brief description of the step. They are intended to be used by the experienced technician, one who only needs a brief reminder of the set-up sequence.
- Descriptive text—The descriptive text explains in detail what is to be done during that step. This explanation is intended as a guide for the technician needing additional information.
- Photographs/Line art—The photographs or line art support both the sub-headings and the detailed text.



Indicates the Set-up section



Indicates the Pre-delivery section

Modifications and Accessories

Modifications that you may have made, or should make in the future, to any Honda product, shall be deemed by our company to have been performed at your sole risk and responsibility, and without our company's or the manufacturer's approval, or consent, implied or expressed. We further disclaim any and all liability, obligation, or responsibility for any defects of modified parts or of the modified product, and for any claims, demands, or causes of action for damage to property or for personal injuries resulting from the modification of said Honda product.

Torque Table

ITEM	SIZE	TORQUE
Handlebar bolts	8 mm	27 N·m (2.8 kgf·m, 20 lbf-ft)
Handlebar weight	6 mm	10 N·m (1.0 kgf·m, 7 lbf-ft)
Master cylinder holder bolts	6 mm	12 N·m (1.2 kgf·m, 9 lbf-ft)
Clutch lever holder bolts	6 mm	12 N·m (1.2 kgf·m, 9 lbf-ft)
Footpeg socket bolts	8 mm	27 N·m (2.8 kgf·m, 20 lbf-ft)
Rear axle nut	-----	93 N·m (9.5 kgf·m, 69 lbf-ft)



1. Remove the carton cover and check for damage.

The CB900F is crated at the factory in either a covered or uncovered crate. You may receive either one.

Covered crate:

Cut the strap and remove the carton cover. Remove the cardboard top.

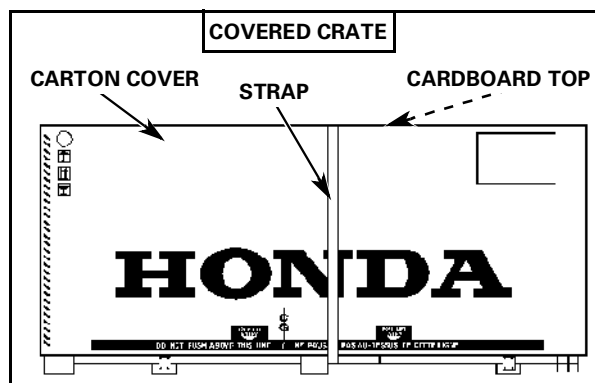

Uncovered crate:

When stacking, protect the motorcycle from falling objects and bad weather.

Check the motorcycle for hidden damage. If you find damage, follow the instructions on the *Delivery and Damage Claims Guidelines* wall chart (Reorder No. S0477) before proceeding.

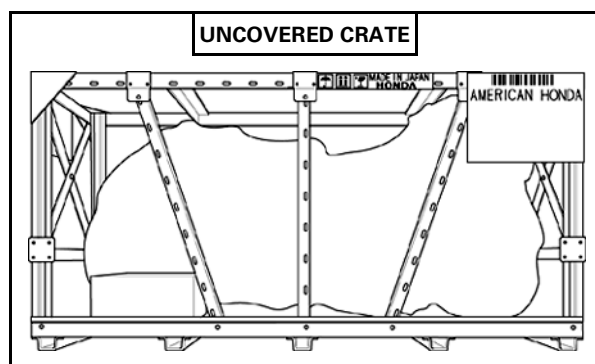

2. Remove the master cylinder and the clutch lever assembly.

Remove the bolt and the front brake master cylinder.

Do not allow the master cylinder to hang by its hose. The weight of the assembly could damage the hose.

Remove the bolt and the clutch lever assembly.

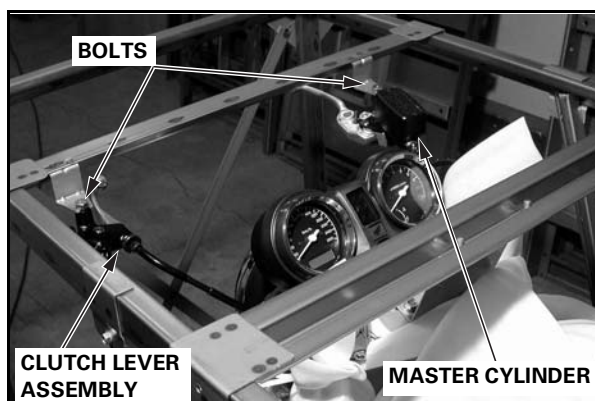

3. Remove the front shipping brace.

Remove the nuts and the front shipping brace.

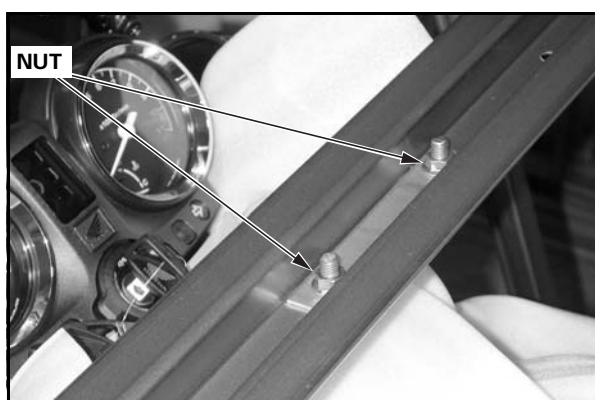

2005 CB900F

4. Remove the crate frame and the loose parts carton.

Remove the bolts and braces. Using two people lift off the crate frame, being careful not to damage the motorcycle.

Cut the strap and remove the loose parts carton.

Keep the *You and Your Motorcycle - Riding Tips & Practice Guide* booklet separate and hand-deliver to the customer at the time of delivery.

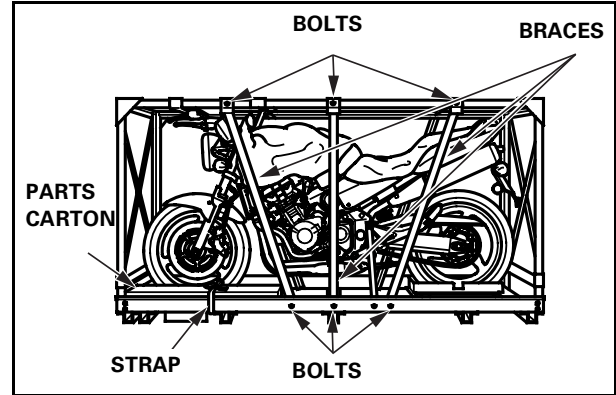



5. Loose Parts Information.

Unpack the remaining loose parts and check them against this illustration and list.

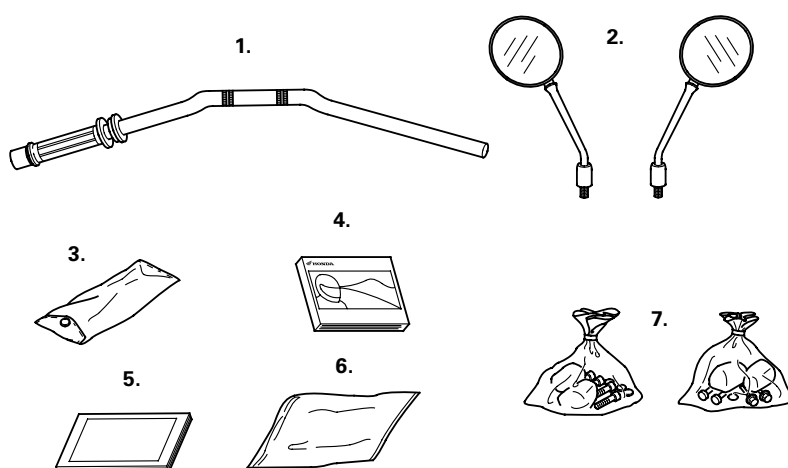

DESCRIPTION	QTY	PART NUMBER	STEP
1. Handlebar	1	53100-MCZ-000	8
2. Mirrors	2	88210-MCC-000	14
3. Tool kit	1	89010-MCZ-000	15
4. Owner's Manual	1	31MCZ630*	15
5. Riding Tips & Practice Guide	1	G0045**	4
6. Manual bag	1	77251-342-000	15
7. Attaching Parts:			
Screw/washer, 5 x 20 mm	1	93892-05020-07	7
Screw/washer, 5 x 25 mm	1	93892-05025-07	7
Handlebar Holder	2	53131-MCZ-000	8
Socket bolt, 8 x 32 mm	4	96600-08032-10	8
Socket bolt cap, 8 mm	4	91455-KEA-000	8
Handlebar weight	1	53105-MK4-620	9
Oval crew, 6 x 65 mm	1	90191-KBG-000	9
Master cylinder holder	2	45517-166-006	10 & 12
Flange bolt, 6 x 22 mm	2	90101-MBZ-G00	10
Screw/washer, 5 x 45 mm	1	93892-05045-07	11
Screw/washer, 5 x 35 mm	1	93892-05035-07	11
Flange bolt, small head, 6 x 22 mm (clutch side)	2	96001-06022-07	12
Socket bolt, 8 x 22 mm	2	90157-ME9-000	13

*If missing, order from Helm Inc.

**If missing, order from Resolve Corp.

Missing Parts or Shipping Damage

Identify missing parts by referring to the *Loose Parts Information* section. Order the parts using normal parts ordering procedures. Claims for missing loose parts or those damaged during transit should be submitted to American Honda, not the carrier. After completing repairs, submit a Transportation Claim via *iN*. For complete details, please refer to the Warranty Policy and Procedures Manual.

2005 CB900F

6. Remove the front shipping bracket.

Remove the bolts and front shipping bracket from the handlebar mount.

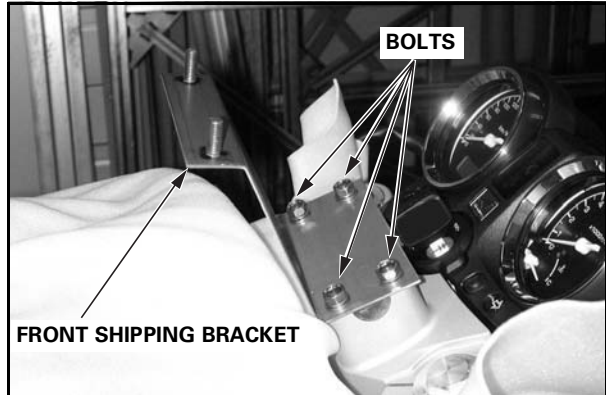

7. Install the throttle grip.

Remove the protective wrap from the throttle grip/switch assembly.

Slide the throttle grip/switch assembly onto the right side of the handlebar. Move the grip until the pin in the switch assembly drops into the hole in the handlebar.

Close the bottom half of the switch assembly and secure the halves using a 5 x 20 mm screw/washer in the front hole and a 5 x 25 mm screw/washer in the rear hole. Torque the screw/washers, starting with the front one.

Torque: 4 N·m (0.4 kgf·m, 3 lbf·ft)

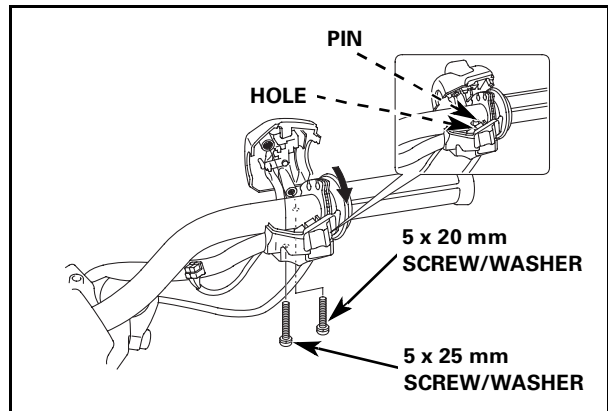

8. Install the handlebars.

Align the handlebar punch mark with the top edge of the lower holder.

Set the upper holders onto the handlebar with their punch marks to the front.

Attach the handlebar using four 8 x 32 mm socket bolts. Torque the four bolts starting with the front two.

Torque: 27 N·m (2.8 kgf·m, 20 lbf·ft)

Attach the socket bolt caps to the handlebar bolts.

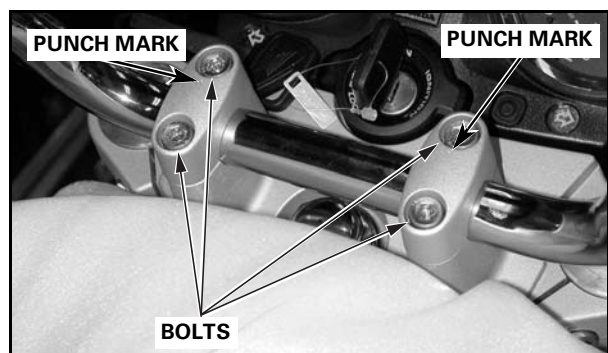
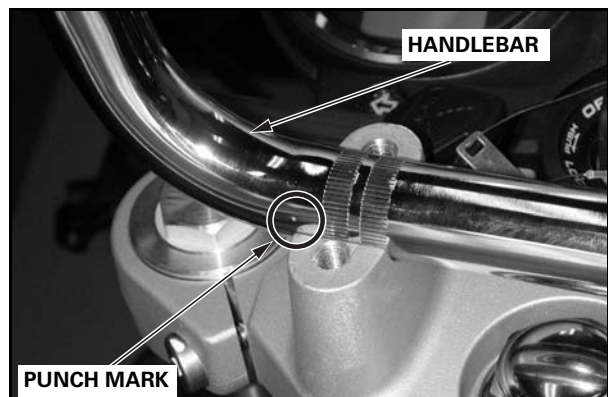



9. Attach the handlebar weight.

Align the tab on the handlebar weight with the recess in the handlebar.

Insert the weight into the handlebar and attach it with a 6 x 65 mm oval head screw.

Torque the screw.

Torque: 10 N·m (1.0 kgf·m, 7 lbf·ft)



10. Install the front brake master cylinder.

Place the master cylinder assembly on the handlebar. Align the edge of the assembly with the punch mark on the handlebar.

Set the master cylinder holder, with its UP mark facing up, on the assembly.

Attach it using two 6 x 22 mm flange bolts.

Torque the two bolts, starting with the top one.

Torque: 12 N·m (1.2 kgf·m, 9 lbf·ft)

Connect the brake light wires to the master cylinder terminals.

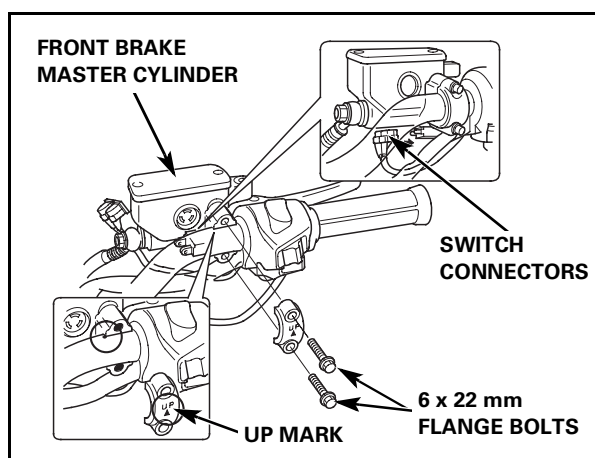

11. Install the turn signal switch.

Position the switch assembly on the handlebar by inserting its pin into the hole in the handlebar and aligning the end cap with the groove in the switch assembly.

Attach the switch assembly using a 5 x 45 mm screw/washer in the front hole and a 5 x 35 mm screw/washer in the rear hole.

Torque the screw/washers, starting with the front one.

Torque: 4 N·m (0.4 kgf·m, 3 lbf·ft)

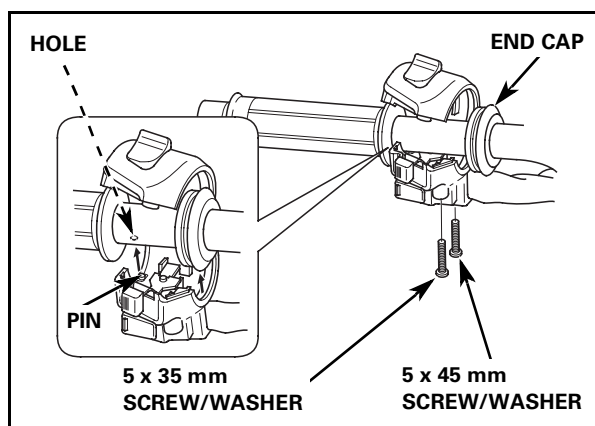

2005 CB900F

12. Install the clutch lever assembly.

Position the clutch lever assembly on the left side of the handlebar. Loosely attach it using its holder and two 6 x 22 mm small head flange bolts. Be sure the holder's UP mark is facing up.

Align the split between the holder and lever assembly with the punch mark on the handlebar.

Torque the two bolts, starting with the top bolt first.

Torque: 12 N-m (1.2 kgf-m, 9 lbf-ft)

Connect the clutch switch connectors to the switch terminals.

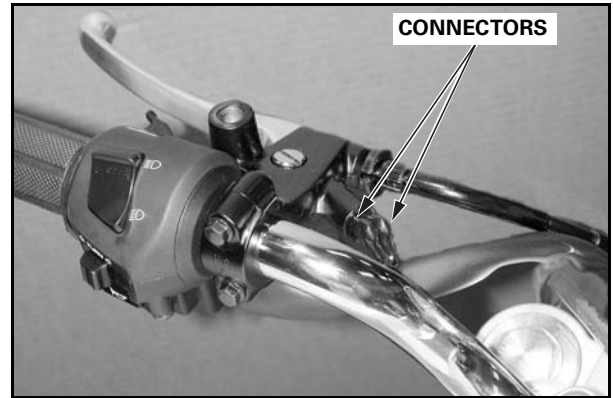
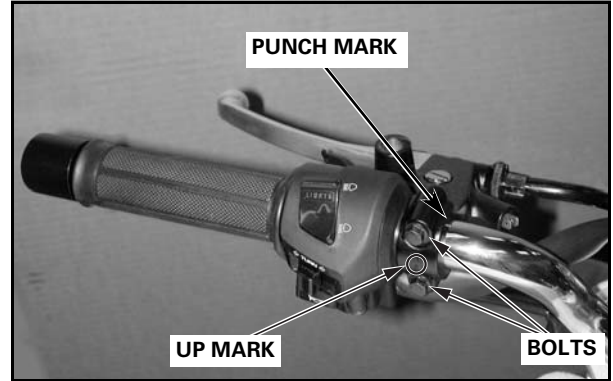

13. Remove the motorcycle from the crate base.

Route a sling under the steering stem. Be sure not to trap any cables, hoses or wires between the sling and the frame.

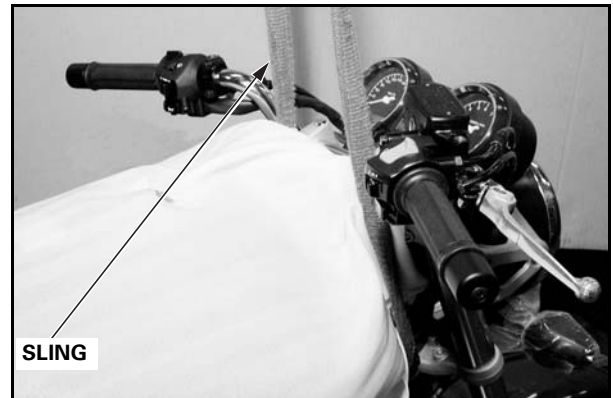

Route another sling through the rear wheel. Attach the slings to a fork lift or similar lifting device and apply just enough tension to the slings to support the motorcycle.

Use a spreader board, if needed, to prevent the sling from rubbing on the rear body.

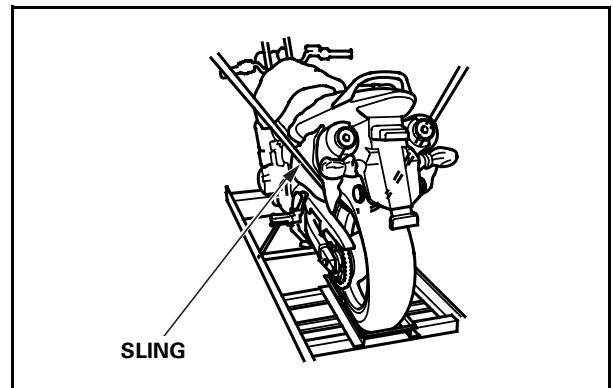



13. Remove the motorcycle from the crate base (cont.).

Remove the 6 and 8 mm bolts and right crate shipping brace.

Remove the 6 and 8 mm bolts and left crate shipping brace.

Discard the bolts.

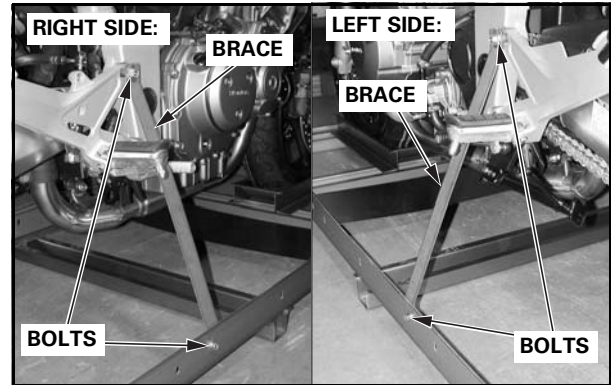

Install and torque the 8 x 22 mm socket bolts securing the footpeg brackets.

Torque: 27 N·m (2.8 kgf·m, 20 lbf·ft)

Lower the side stand and place the motorcycle on a level surface.

Remove the slings.

Clean both sides of all the brake discs using Pro Honda Brake Cleaner or equivalent and a clean shop towel.

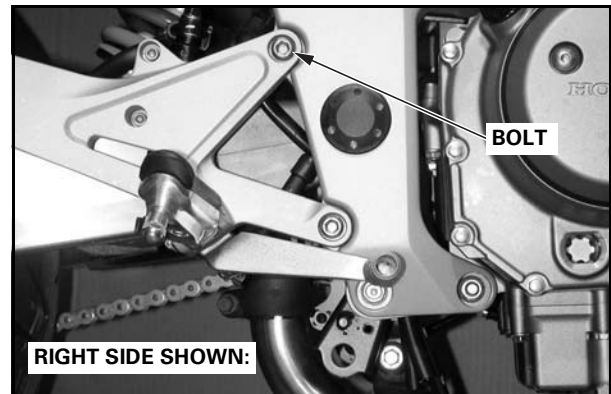

14. Install the mirrors.

Thread the mirrors into their mounts and secure them by tightening their lock nuts.

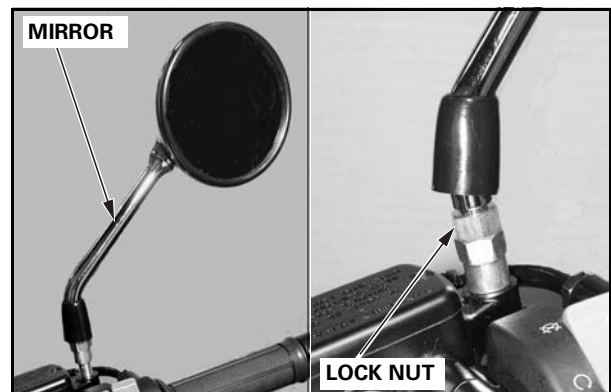

15. Store the Owner's Manual and tool kit.

Insert the ignition key into the seat lock. Turn the key clockwise to release the seat. Pull the seat back and off the motorcycle.

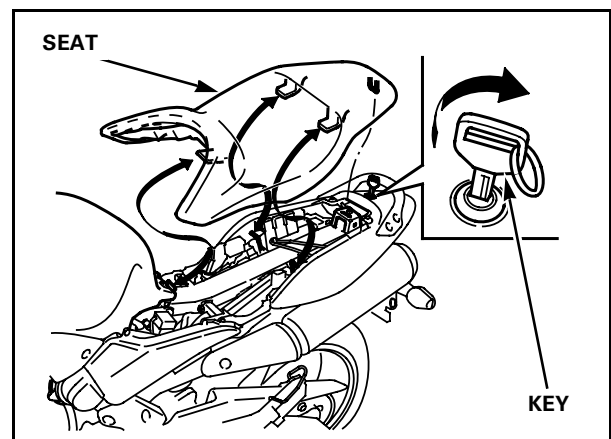

2005 CB900F

15. Store the Owner's Manual and tool kit (cont.).

Place the tool kit in the holder and secure it with the rubber restraining strap.

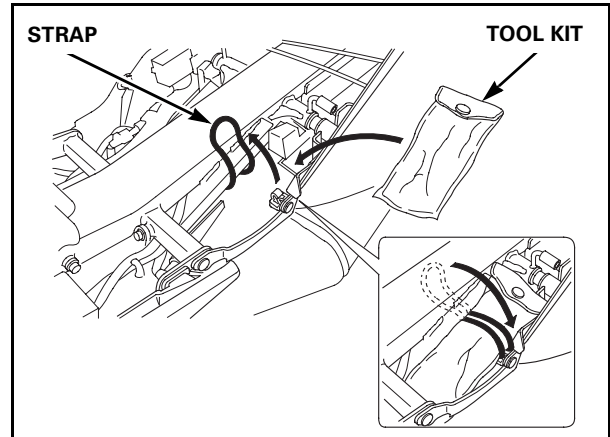

Place the Owner's Manual in its bag and secure it in the holder located on the bottom of the seat.

If the pre-delivery inspection is to be completed directly after set-up, leave the seat off. If not, reinstall the seat.

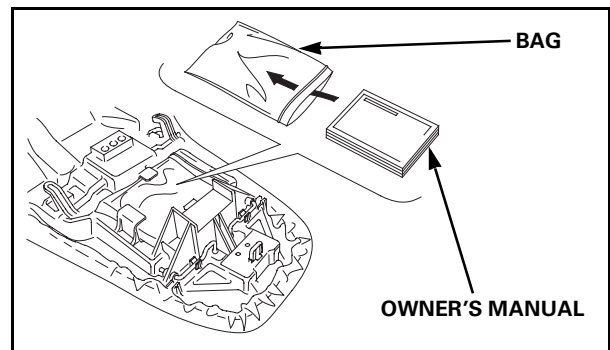



16. Check the cables, hoses, and wire harness routing.

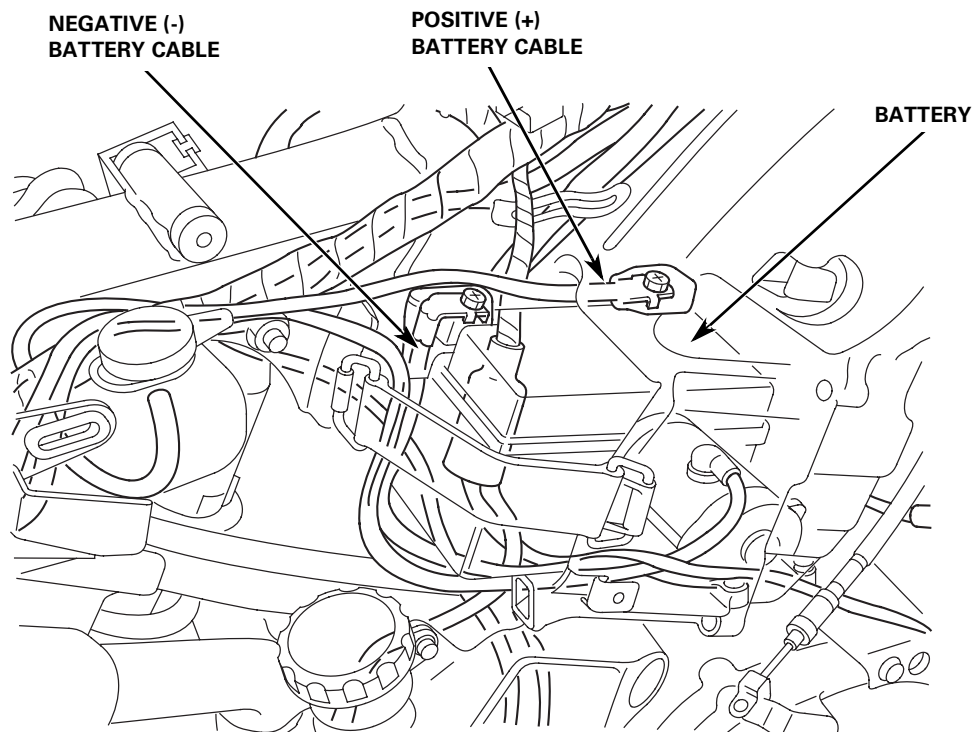
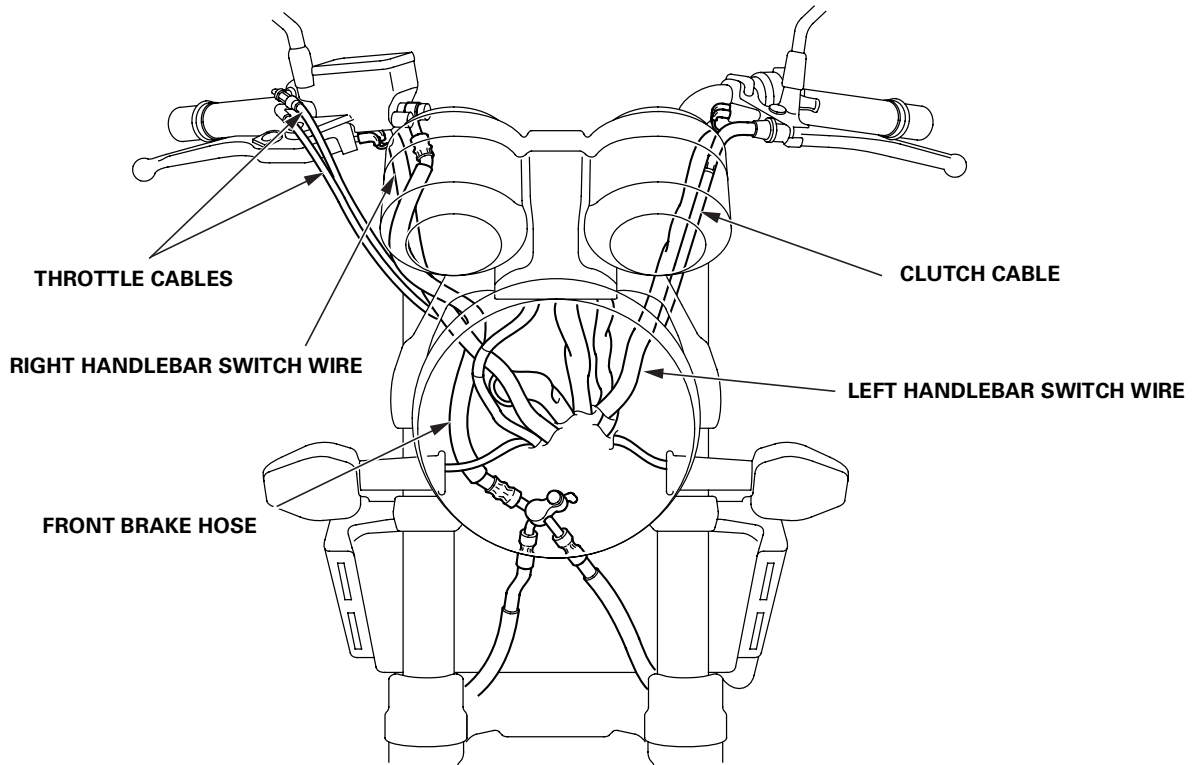

2005 CB900F

17. Service and install the battery.

Service the battery only if the motorcycle has been sold or is to be used as a demonstration vehicle.

Remove the seat (see step 15).

Remove the bolt, then pull back the right side cover from the motorcycle.

Follow the instructions included on the battery case and in *Service Letter #48*.

The battery used in this motorcycle is a pre-charged, maintenance-free type. The electrolyte has already been added to the battery.

Do not connect the motorcycle battery cables to the battery terminals until the motorcycle is ready for delivery.

Place the ignition in the OFF position.

Remove the battery hold-down strap and battery.

Remove the protective cap from the positive (+) battery terminal.

Slide the battery terminal nut into the battery positive (+) terminal. Connect the battery positive (+) cable to the positive (+) battery terminal, tighten the bolt, coat the terminal with dielectric grease, then pull the red cover over the positive terminal.

Set the battery into the battery box. Install the battery hold-down strap.

Slide the battery terminal nut into the battery negative (-) terminal. Connect the battery negative (-) cable to the negative (-) battery terminal, tighten the bolt, coat the terminal with dielectric grease, then pull the cover over the negative terminal.

Reinstall the side cover and seat.

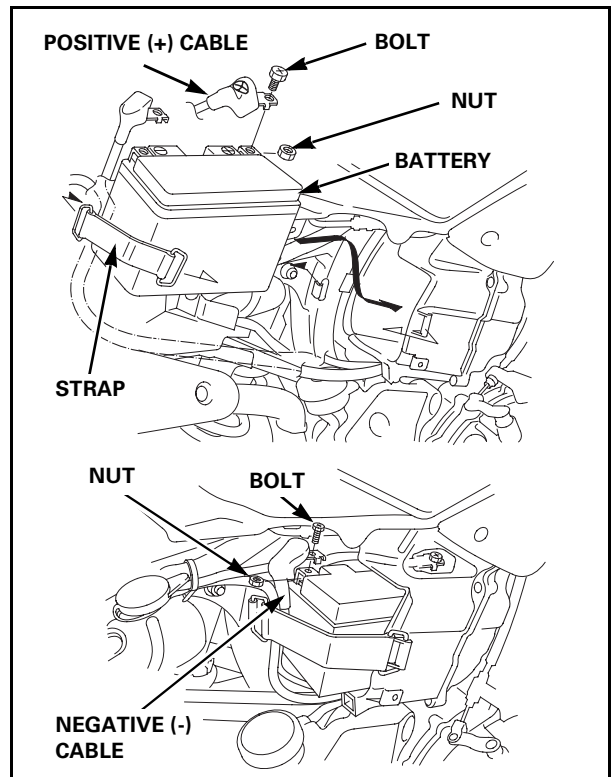
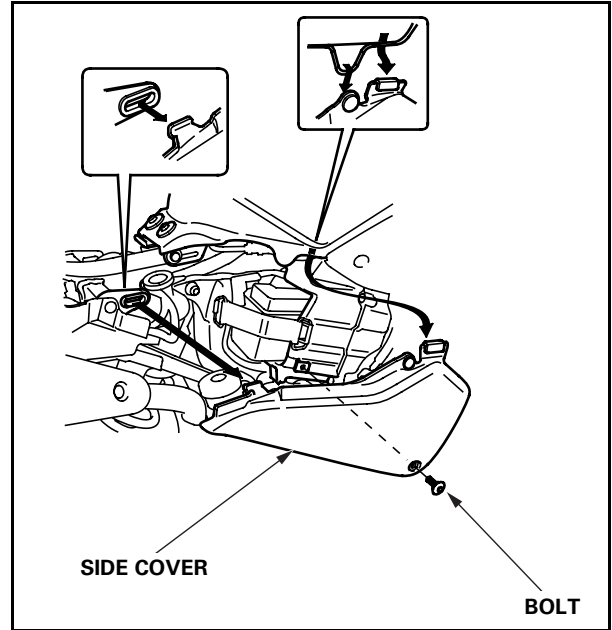



18. Check the throttle operation.

Check the throttle cable for damage.

Check that the throttle returns from all open positions to the fully closed position smoothly and automatically in all steering positions.

Measure the throttle grip free play.

**Throttle grip free play: 2 – 4 mm
(1/16 – 3/16 in.)**

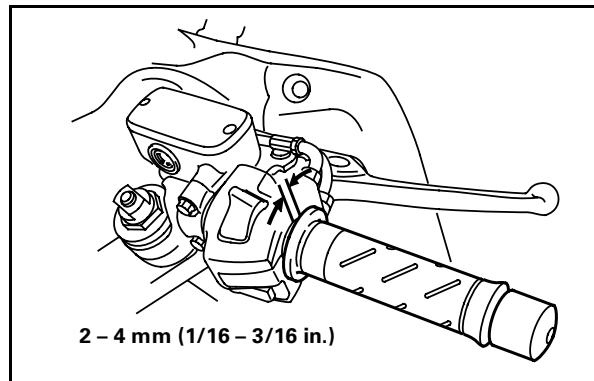

To adjust free play:

- Make small adjustments at the throttle grip adjuster. Loosen the lock nut and turn the adjuster. Tighten the lock nut after adjusting.
- Make large adjustments at the throttle body end. Loosen the lock nut and the adjuster nut. Tighten the lock nuts after adjusting.

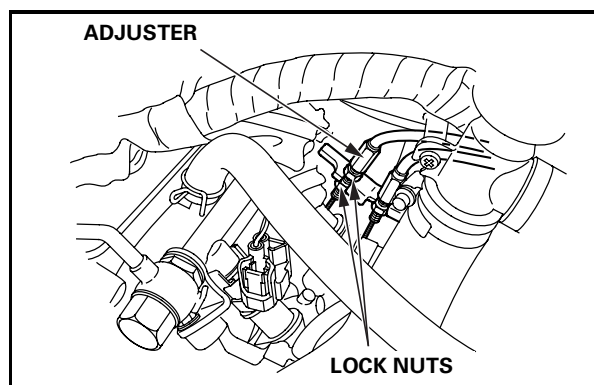
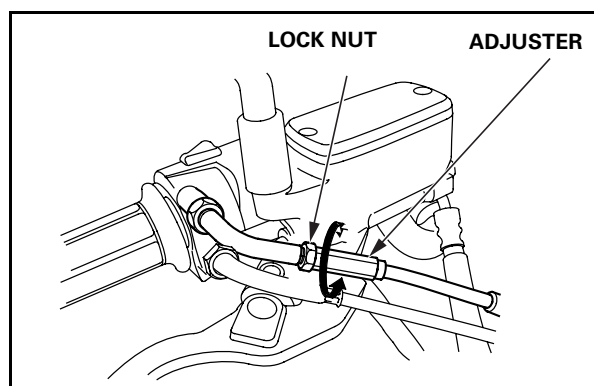

2005 CB900F

19. Check the clutch lever free play.

Measure the clutch lever free play at the lever tip.

Clutch lever free play: 10 - 20 mm (3/8 - 13/16 in)

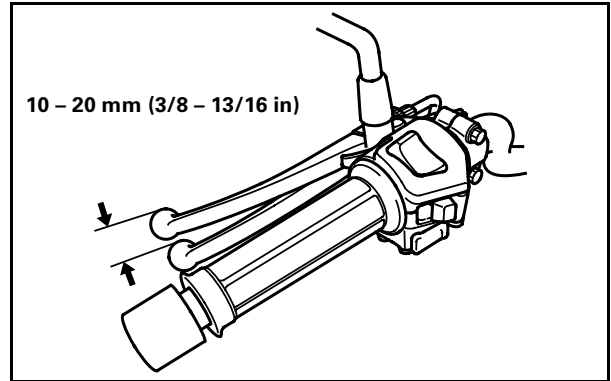

To adjust the free play:

- Make small adjustments at the lever end of the cable. Loosen the lock nut and turn the adjuster. Tighten the lock nut after adjusting.
- Before making any large adjustments, loosen the lever adjuster lock nut, turn the adjuster in completely, then turn it out one or two turns.
- Make large adjustments at the engine end of the cable. Loosen the lock nut and turn the adjustment nut. Tighten the lock nut after adjusting.

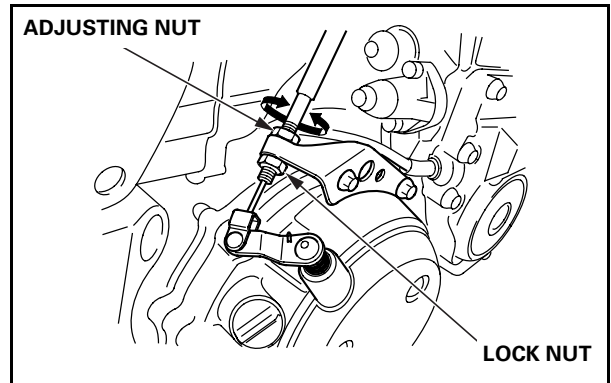
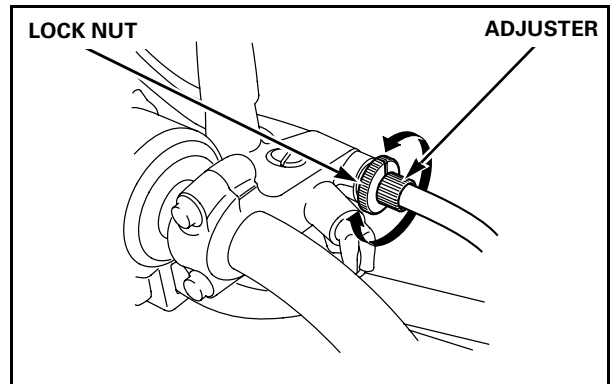

20. Adjust the brake light switch.

Turn on the ignition switch.

Adjust the rear brake light switch so the light comes on as the brake begins to engage.

Avoid turning the switch body. Turning the switch body will twist the wires and could cause a short circuit.

To adjust, turn the adjuster, not the body.

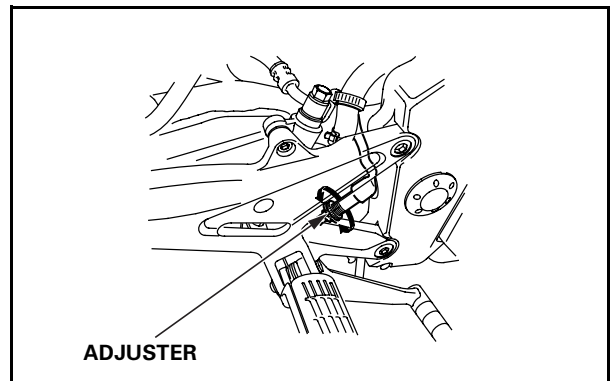



21. Check the engine oil.

Before starting the engine, remove the anti-rust coating from the engine and exhaust system using a mild detergent and water. Rinse with clean water.

Support the motorcycle in an upright position on a firm, level surface.

Check the oil inspection window to be sure the engine has oil.

If no oil is present in the window, remove the oil filler cap and add the recommended oil to bring the level up to between the upper and lower level marks.

- **Oil recommendation: Pro Honda GN4 or HP4 (without molybdenum additives) 4-stroke oil, or an equivalent motorcycle oil.**
- **Viscosity (weight): SAE, 10W-40**
- **API classification: SF or higher. Do not use oils labeled as energy conserving on the circular API service label.**
- **JASO T 903 standard: MA**
- **Crankcase capacity: 3.5 Liters (3.7 US Quarts)**

Start the engine and let it idle for 3 - 5 minutes, then shut it off. Wait 2 - 3 minutes and, supporting the motorcycle in an upright position, check the oil inspection window. The oil level should be between the upper and lower level marks. If the level is low, add the recommended oil as detailed above. Do not add oil above the upper level mark.

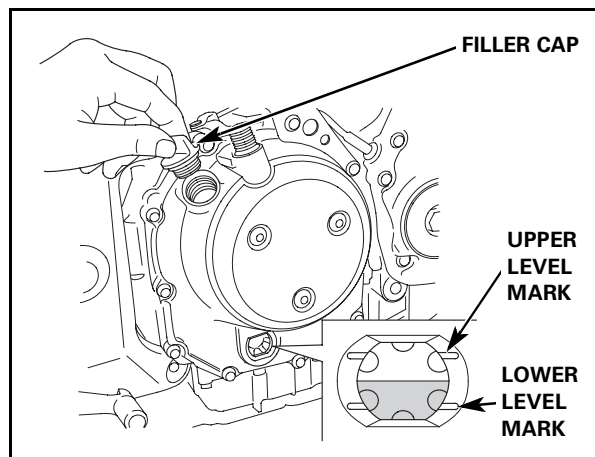

22. Check the coolant level.

Check the coolant level at the reserve tank located behind the side cover on the left side.

If required, add Pro Honda HP coolant or an equivalent high quality ethylene glycol antifreeze containing silicate-free corrosion inhibitors to restore the level to the UPPER mark.

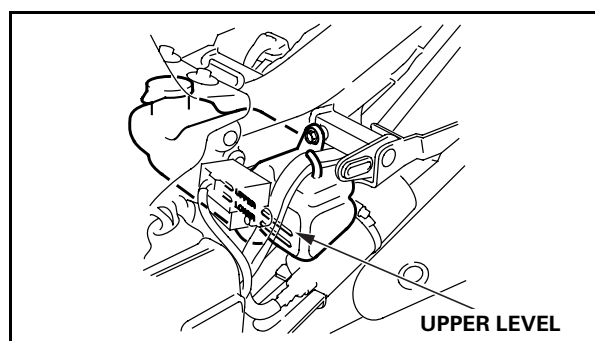

2005 CB900F

23. Check the idle speed.

Support the motorcycle on its side stand on a firm, level surface.

Connect a tachometer to the engine. Place the transmission in neutral.

Start the engine and warm it to the normal operating temperature. Verify the engine idle speed.

Idle speed: 1,200 ± 100 rpm

Use only the throttle stop screw to make idle speed adjustments.



24. Verify the drive chain slack.

Place the motorcycle on the side stand and put the transmission in neutral.

Check the drive chain slack midway on the lower chain run.

Drive chain slack:

30 – 40 mm (1 3/16 – 1 9/16 in.)

Adjust the slack by loosening the axle nut and the adjustment lock nuts. Turn the adjustment bolts to set the proper chain slack.

Set the wheel alignment using the alignment marks on the swingarm and the notches on the axle holders. Be sure both sides are set to the same position.

Torque the axle nut and tighten the lock nuts on both sides.

Torque: 93 N-m (9.5 kgf-m, 69 lbf-ft)

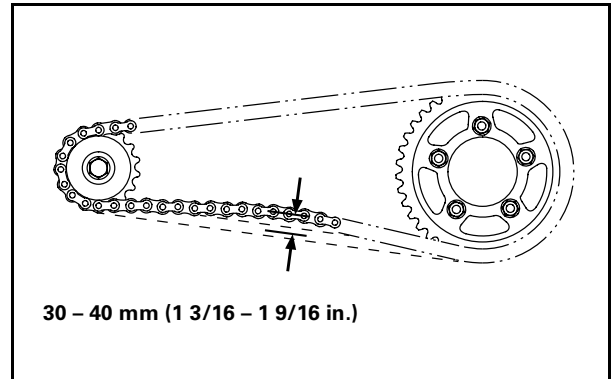

25. Check the tire pressure.

Front: 36 psi Rear: 41 psi

26. Complete the Set-Up/ Pre-Delivery Checklist.

Complete an *On-Road Set-Up/Pre-Delivery Checklist* (Reorder No. S0299) by checking the boxes confirming that the steps were done.

