

### Preparation

**Part Number(s): Multiple**

#### Kit Contents

Item #	Qty Req'd	Description
1	1	BedTred Floor Panel
2	1	BedTred Bulkhead Panel
3	2	BedTred Sidewall Panels (L&R)
4	1	BedTred Tailgate Panel
5	1	1" x 63.5" Adhesive Bk. Hook
6	5	1" x 60" Adhesive Bk. Hook
7	25	1" x 2" Adhesive Bk. Hook
8	6	1" x 10" Adhesive Bk. Hook
9	4	1" x 6" Adhesive Bk. Hook
10	1	#4298 Adhesive Promotor Pad
11	1	6' roll 2" Non-adhesive Hook
12	1	Printed set of Instructions

#### Additional Items Required for Installation

Item #	Quantity Req'd	Description

#### Recommended Tools

Personal and Vehicle Protection	Notes:
Safety Glasses	
Gloves	
Special Tools	
Various	Tools required to remove tiedowns (unique to vehicle)
Installation Tools	
Utility Knife	To cut slits or to trim BedTred for cargo mgmt. system
Scissors	To cut hook tape to length
Awl	To locate holes for cargo hook attachment bolts (or other accessories)
Special Chemicals	
Approved Cleaner	70% (or higher) Isopropyl Alcohol

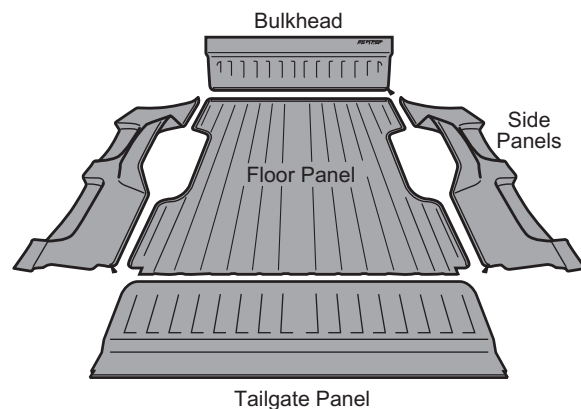

This document covers such items as:

- Vehicle Preparation (use of cleaners, adhesive promoters, etc.)
- Safety (rechecking torque procedure, etc.)
- BedTred installation





**WARNING: IMPROPER INSTALLATION WILL RESULT IN LINER FLYING OUT OF THE TRUCK. FOLLOW INSTRUCTIONS EXACTLY**

**IMPORTANT:** Read all instructions before beginning installation. Be sure to dispose of all adhesive backing tape in the trash.

#### General Applications

Multiple
----------

#### Legend

	<b>STOP:</b> Damage to the vehicle may occur. Do not proceed until process has been completed.
	<b>OPERATOR SAFETY:</b> Use caution to avoid risk of injury.
	<b>CAUTION:</b> A process that must be carefully observed in order to reduce the risk of damage to the accessory/vehicle and to ensure a quality installation.
	<b>TOOLS &amp; EQUIPMENT:</b> Calls out the specific tools and equipment recommended for this process.

#### 1. Check Kit Contents

- Verify that your kit contains all the parts listed in the Kit Contents.
- Test fit all parts in truck bed prior to installation to determine correct location for best appearance.

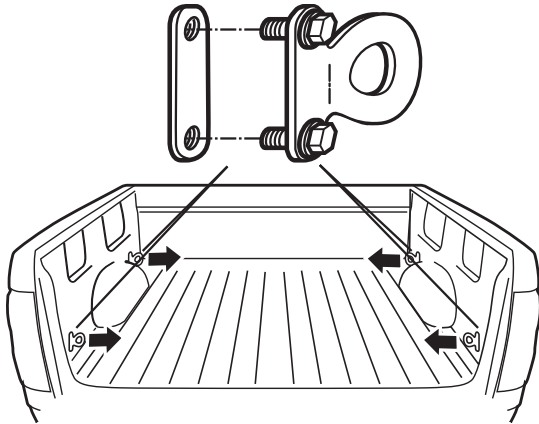

### 2. Vehicle Preparation

a. **Wash and Dry** the bed and tailgate area thoroughly before proceeding.

b. Remove bolt-in type cargo hooks or load extenders (if equipped) Cargo hooks will be reinstalled in Step 10.



**IMPORTANT:** Truck bed should be at least 68°F (20°C) for maximum adhesion. Clean all areas with 70% (or higher) Isopropyl Alcohol before applying tape. Do not remove backing from any tape until ready to adhere to the truck bed. When removing backing, do not touch adhesive. Extra adhesive strips have been provided in the kit for future use or if the installer deems more fasteners are necessary for better fit and appearance.

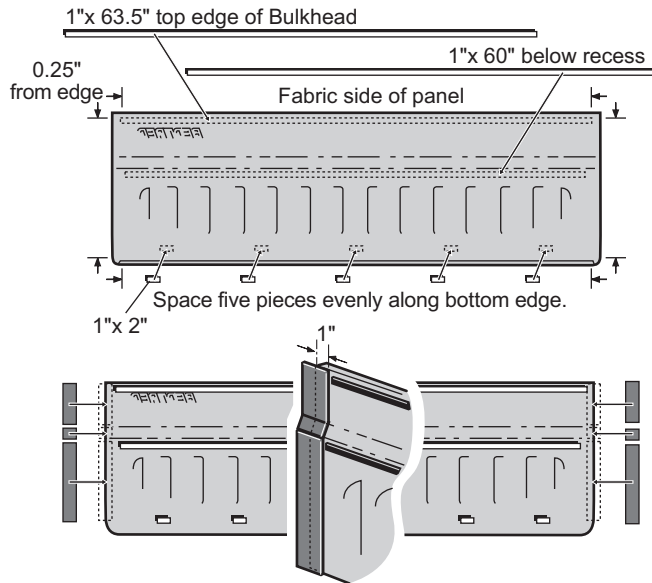

### 3. Attach Hook Fasteners To BedTred Bulkhead Panel.

a. Apply 63.5" piece and one 60" piece of Hook Fastener to back (loop side) of Bulkhead Panel as shown leaving the adhesive side out and backing in place.

b. Apply five pieces of 2" Hook Fastener to the loop side at the bottom of Bulkhead Panel.



c. Cut pieces of the 2" wide Hook Fastener **without adhesive** tape and attach to Bulkhead Panel.



Leave 1" of 2" wide Hook Fastener exposed for future attachment to front edges of side panels in Step 11.

### 4. Attach Hook Fasteners to BedTred Sidewall Panels.

a. Apply three 10" long Hook Fasteners above wheel well and upper tier loading areas as shown. **Do Not Locate in wheel well itself.**



b. Apply 6" pieces at 45° angles outside of each end of wheel well.

c. Apply 2" pieces on top and rear edges as needed.

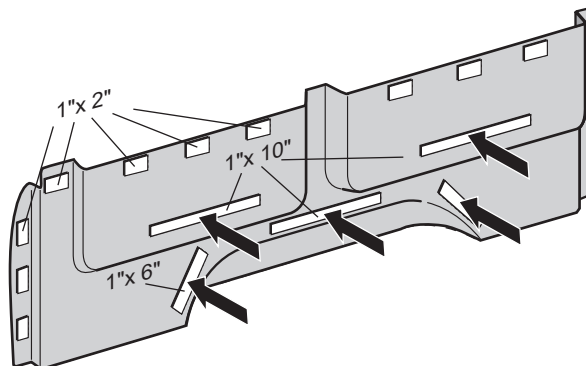

# BEDTRED

## BedTred Truck Bed Liner Installation

### Procedure

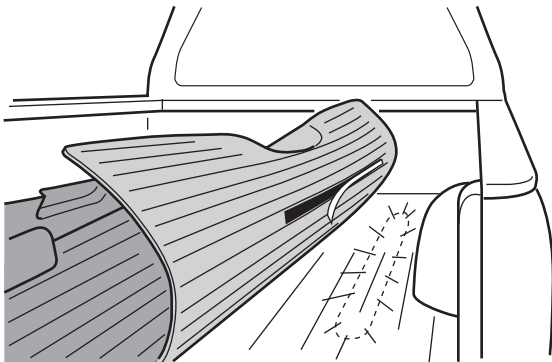
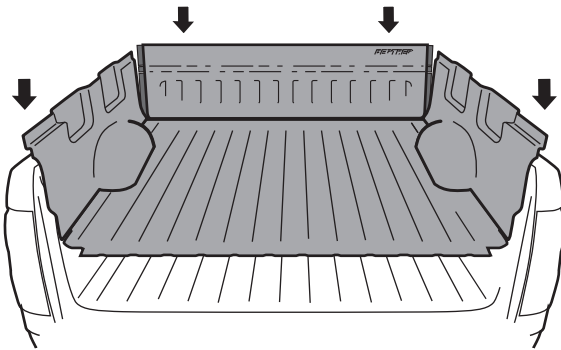
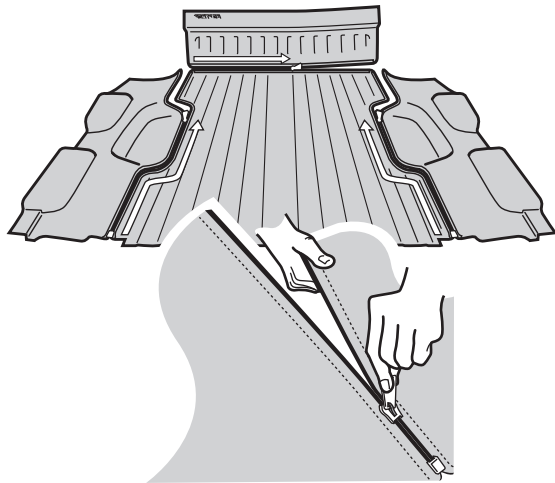
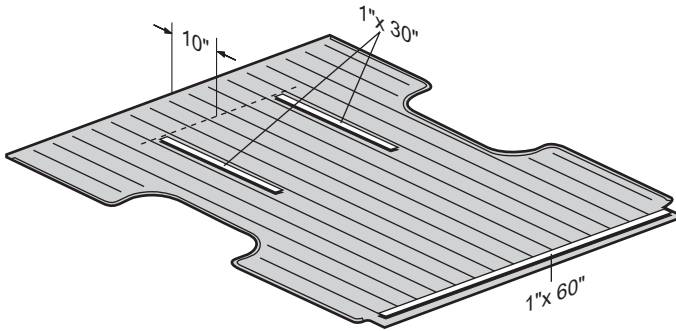

### 5. Attach fasteners to BedTred Floor Panel.

- Cut 1 piece of 1"x 60" in half to achieve two 1"x 30" pieces.
- Apply two 30" pieces to the center areas of the Floor Panel no closer than 10" from the front.



These pieces must be installed in a valley on the BedTred floor, which will be on top of a rib in the floor of the truck.

- Apply one piece of the 1"x 60" to the full width of the rear edge of floor.

### 6. Zip the BedTred truck bed panels together

From the loop side of the panels, zip the two side panels to the Floor Panel (starting at the back of the BedTred) and then zip the Bulkhead Panel to the Floor Panel.

### 7. Place the joined BedTred panels in truck

Turn the BedTred over again and place it carefully into the truck bed.



Position the Floor Panel carefully.

### 8. Adhere the Floor Panel to the truck floor.

Lay the Bulkhead Panel down onto floor, then carefully roll the BedTred over on one side.



Thoroughly clean the area of the floor with alcohol where the adhesive will be applied. Be careful not to crease any of the panels as you fit the BedTred into your truck bed. Remove the tape backing from that adhesive-backed hook and roll the BedTred back into position on that side.



**Be careful not to shift position of the Floor Panel during this step.**

Repeat for the other side.



**Press fasteners firmly in place.**

# BEDTRED

## BedTred Truck Bed Liner Installation

### Procedure

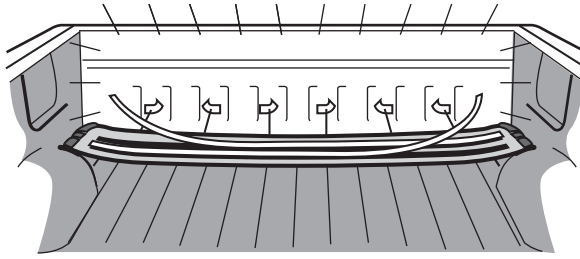

9. **Attach Bulkhead Panel to Truck Bed.**  
Wipe all contact areas with alcohol, then let dry.



Remove backing tape and attach lower fasteners first. Work from the bottom up and the center out.



**IMPORTANT:** Do not remove backing tape until ready to adhere tape to truck bed.



Press all fasteners firmly in place.

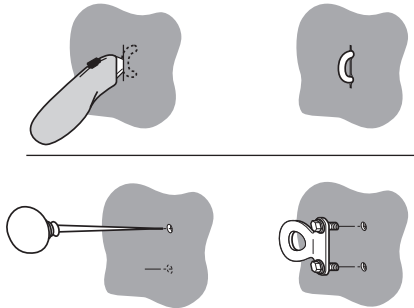

10. **Some Truck beds are equipped with tie-down hooks- load extenders and other equipment on the floor, bulkhead or sidewalls. For these you must either:**



equipment on the floor, bulkhead or sidewalls. For these you must either:



- a. Cut a small slit in the appropriate area, allowing the equipment to protrude through the BedTred surface (this will not damage the BedTred) or,



- b. If you removed the above equipment as noted in Step 2, install the BedTred and then reinstall the equipment over the BedTred surface.



Note: An awl works well to locate and punch holes.

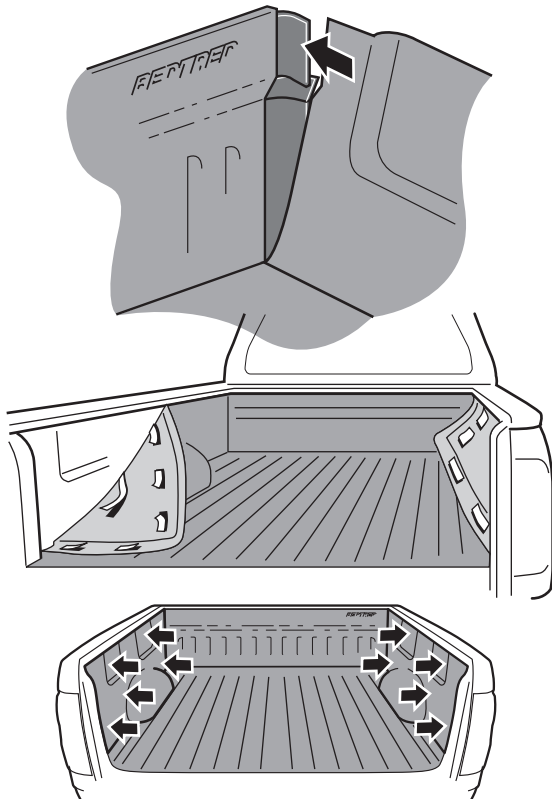

11. **Attach sidewall panels to truck bed.**



Begin by attaching the front edge of the side panel to the Bulkhead Panel. Be sure the 2" wide hook is secure against the fabric side of the side panel.



It is best to center and attach the wheel well area next. Clean attachment areas of bed with alcohol and let dry. Remove backing tapes and adhere to truck.



Work from the bottom up then toward the front and rear.

Repeat with the opposite sides.



Press all fasteners firmly in place.

# BEDTRED

## BedTred Truck Bed Liner Installation

### Procedure

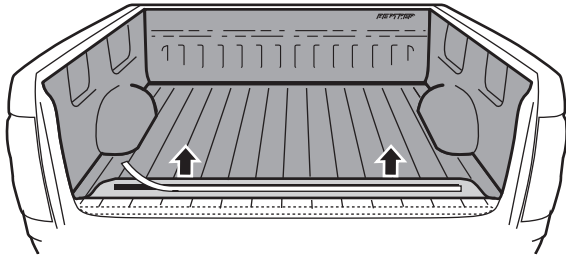

- 12. Finish attaching BedTred Floor Panel**  
Turn the rear flap of the Floor Panel and wipe the truck bed with alcohol and let dry. Remove the backing tape and then secure the BedTred Floor Panel starting in the middle and pressing out to each side.

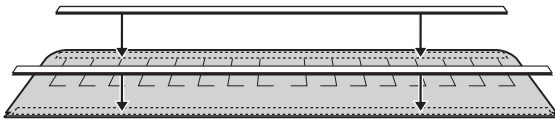

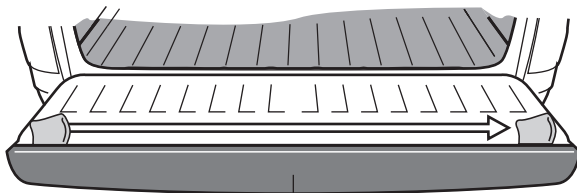

- 13. Prepare BedTred Tailgate Panel**  
Attach 1x60 Hook Fasteners to both the top and bottom edge of tailgate as shown.

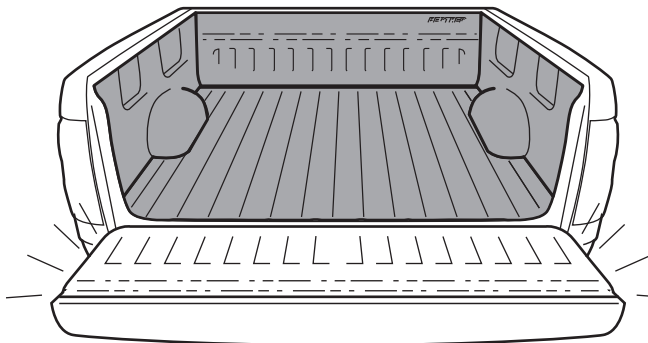

Tailgate Cap

- 14. Attach Tailgate Panel to Truck**  
 If your truck has a plastic tailgate cap. After cleaning with alcohol, apply Adhesive Promotor to the plastic tailgate cap before attaching Hook Fastener.  

-  Clean hook attachment areas with alcohol and let dry.

-  Place Tailgate Panel in proper location. Remove backing tape and attach **top** 1"x 60" fastener.

Press firmly in place.

-  Remove backing tape and attach **bottom** 1"x 60" fastener to truck tailgate.

Press firmly in place.

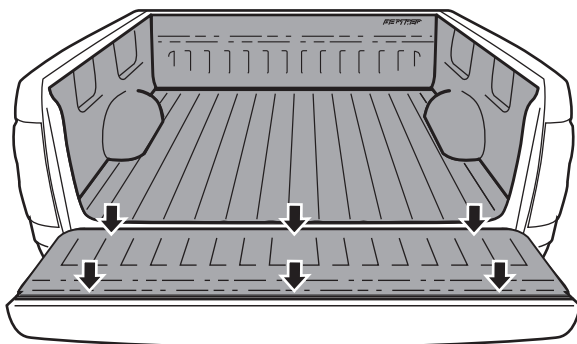

**You have now completed the BedTred Installation.**



## BedTred® CLEANING INSTRUCTIONS

The mildew resistant BedTred foam will not absorb liquids. The engineered polypropylene fiber surfaces resist stains and deterioration from most acids, chemicals, gasoline and oils, etc. Therefore, by following the cleaning instructions below, your BedTred will remain serviceable for as long as you own your truck.

### Cleaning your BedTred is easy:

1. A vacuum, broom, brush or compressed air can be used to remove dirt, grime, sand, mulch, etc. Due to the fact that water will not harm the BedTred, pressure washing is also an effective way to clean a soiled BedTred product. Also, the BedTred floor panel may be taken out to remove any trapped material before it can damage your truck's paint finish.
2. Although most acids will not harm the BedTred, baking soda should be applied immediately to neutralize the acid to ensure the safety of the paint on the truck.
3. To clean tougher jobs such as gasoline, oil, chemicals, acid spills or leaks from your BedTred, use a detergent soap with degreaser and water, then rinse thoroughly. This detergent soap is used in most car wash locations with pressure washing equipment. The BedTred polypropylene closed-cell foam will not absorb water and the polypropylene fiber dries in minutes.

If you have additional questions, call BedRug, Inc. customer service at 800-462-8435.

**Retain these cleaning instructions with your vehicle owner's manual for future reference.**

## BedRug, Inc. LIMITED WARRANTY

BedRug, Inc. warrants BedRug, BedTred, VanRug, and VanTred, for pickup trucks and vans to be free from defects in materials and workmanship. BedRug bedliners will be warranted for the duration of the vehicle ownership by the original BedRug purchaser. The terms of this warranty may vary from state to state. You may have rights under specific state laws that differ from the terms of this warranty. Proof of purchase will be required for warranty service. Customer modifications and/or improper return packaging of the product may void this warranty. Product should be cleaned before returning. For warranty instructions, returns and packaging contact BedRug, Inc. Customer Service at 800-462-8435. Labor and shipping are not covered under the terms of this agreement.

**Retain this warranty information with your vehicle owner's manual for future reference.  
FOR WARRANTY SERVICE, CALL 800-462-8435**