

ARTICLE BEGINNING 

AIR CONDITIONING 

2.2L 

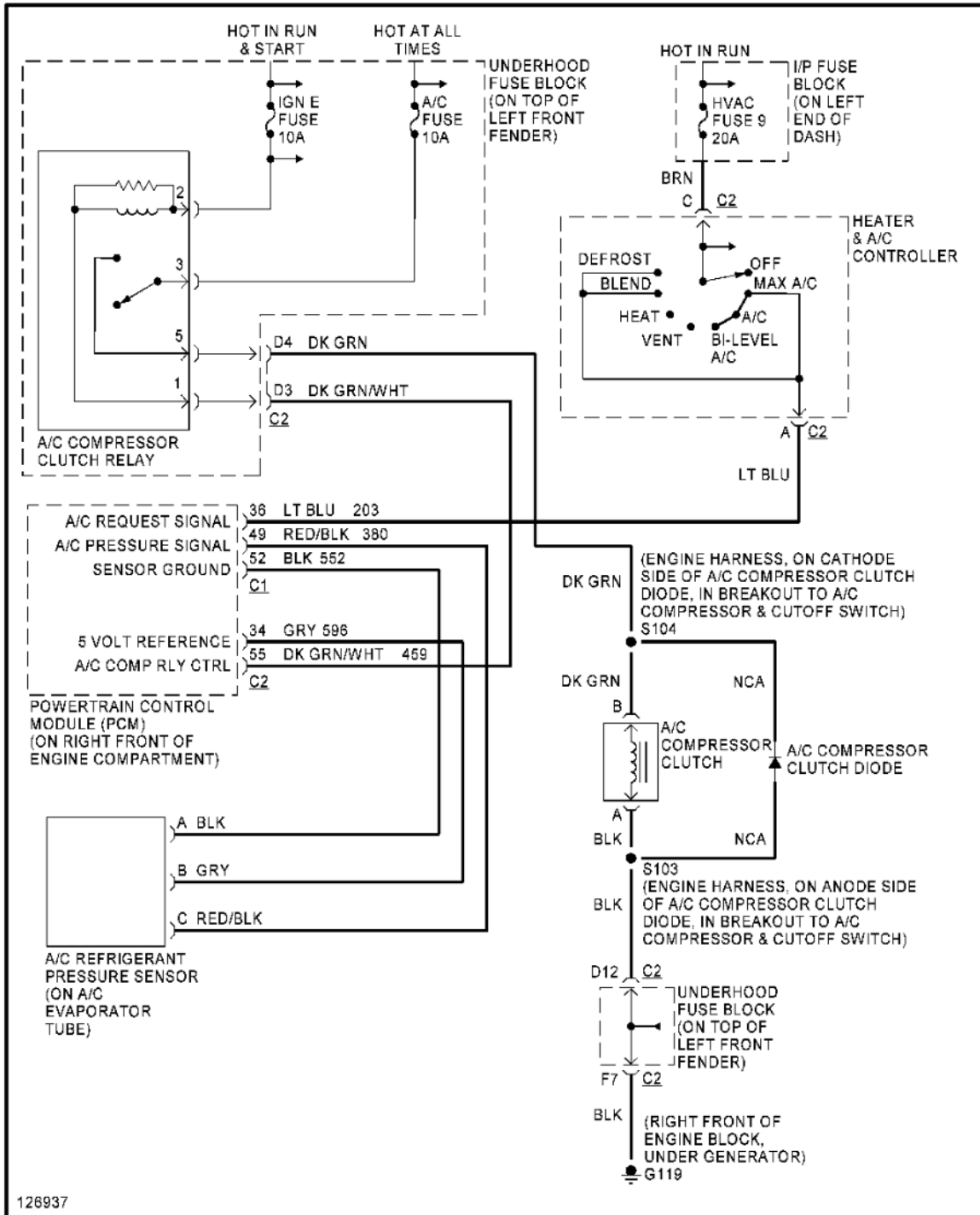

Fig. 1: 2.2L VIN 4, Compressor Circuit

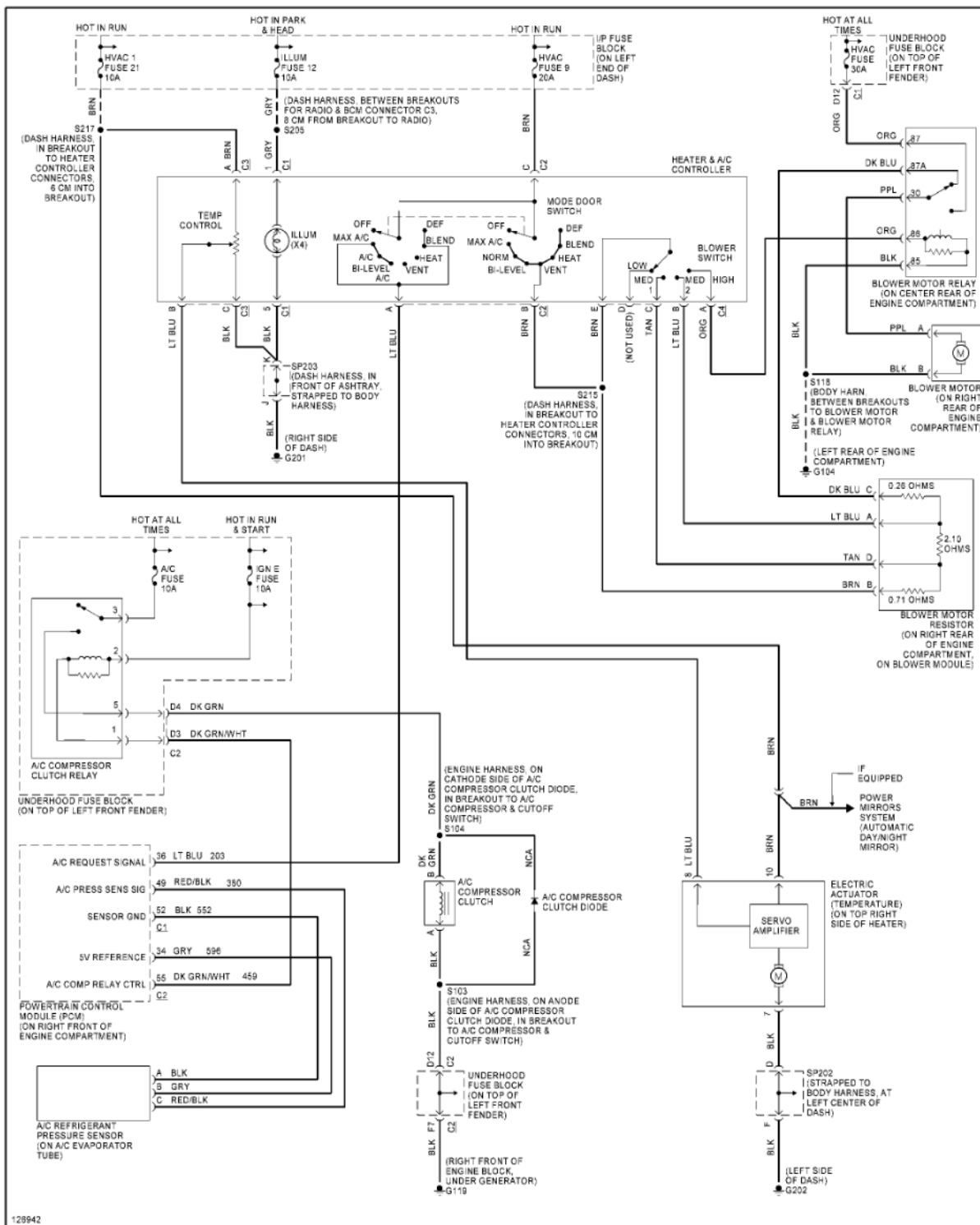

Fig. 2: 2.2L VIN 4, Manual A/C Circuit

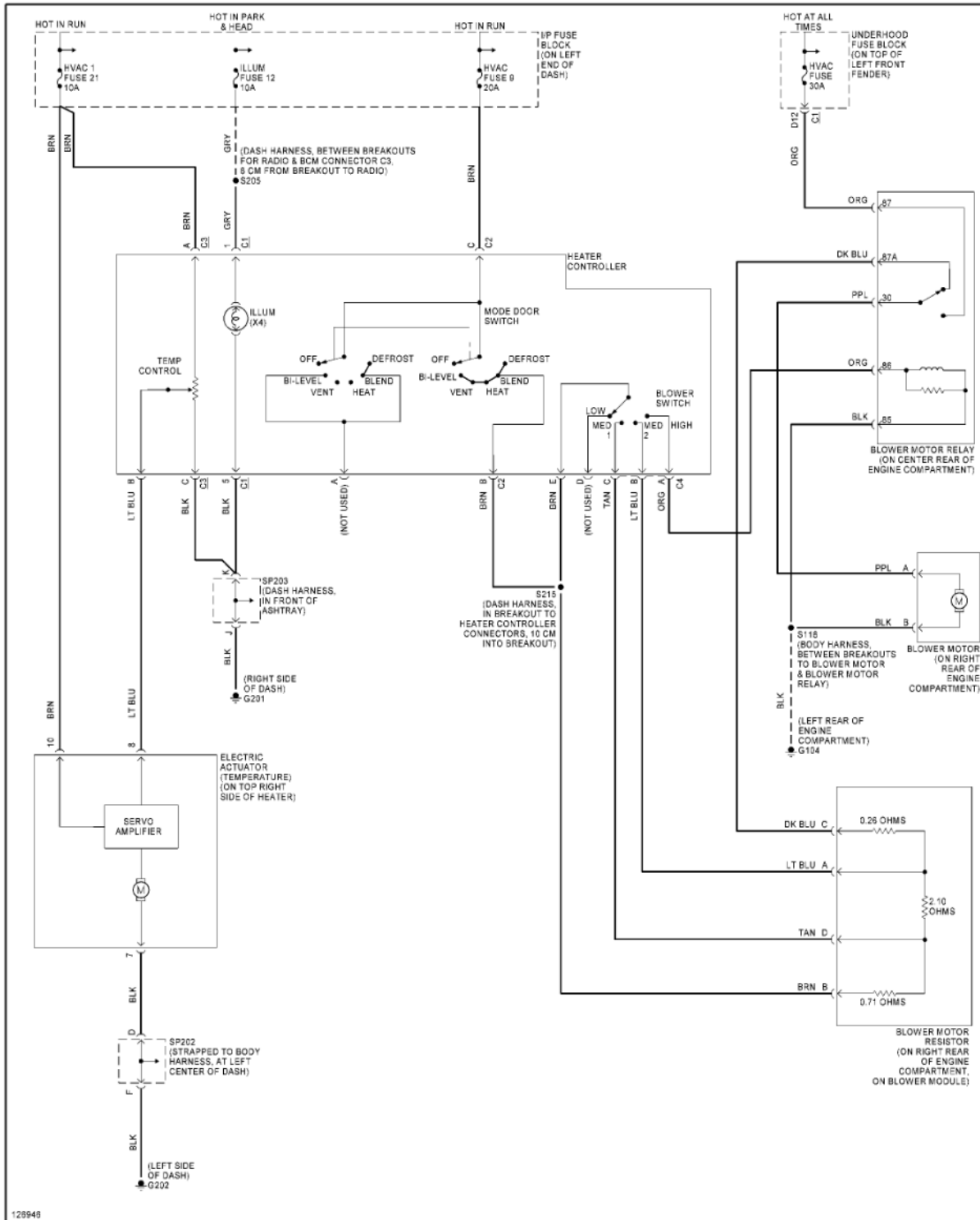

Fig. 3: Heater Circuit

4.3L 

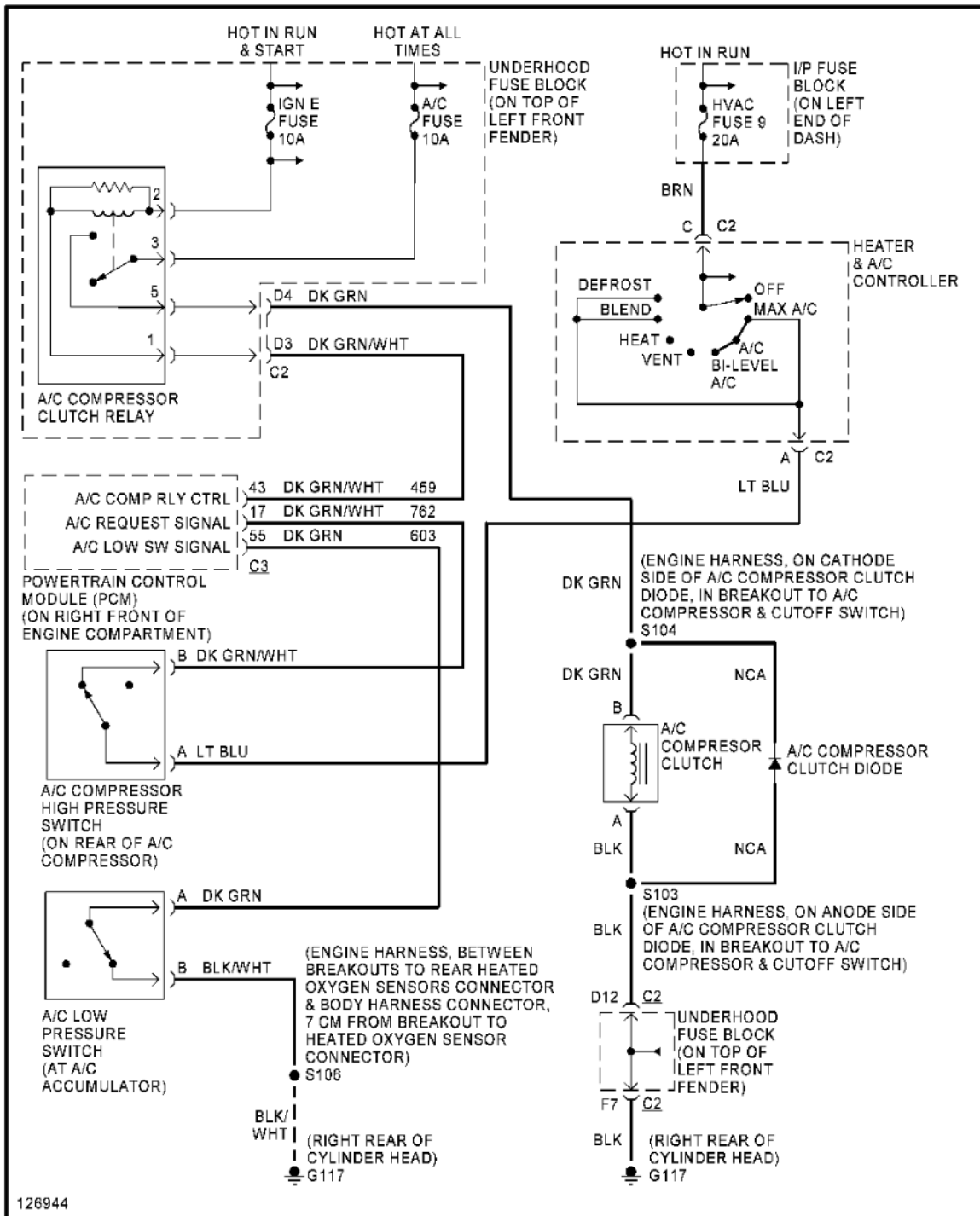

Fig. 4: 4.3L VIN W, Compressor Circuit, Manual A/C

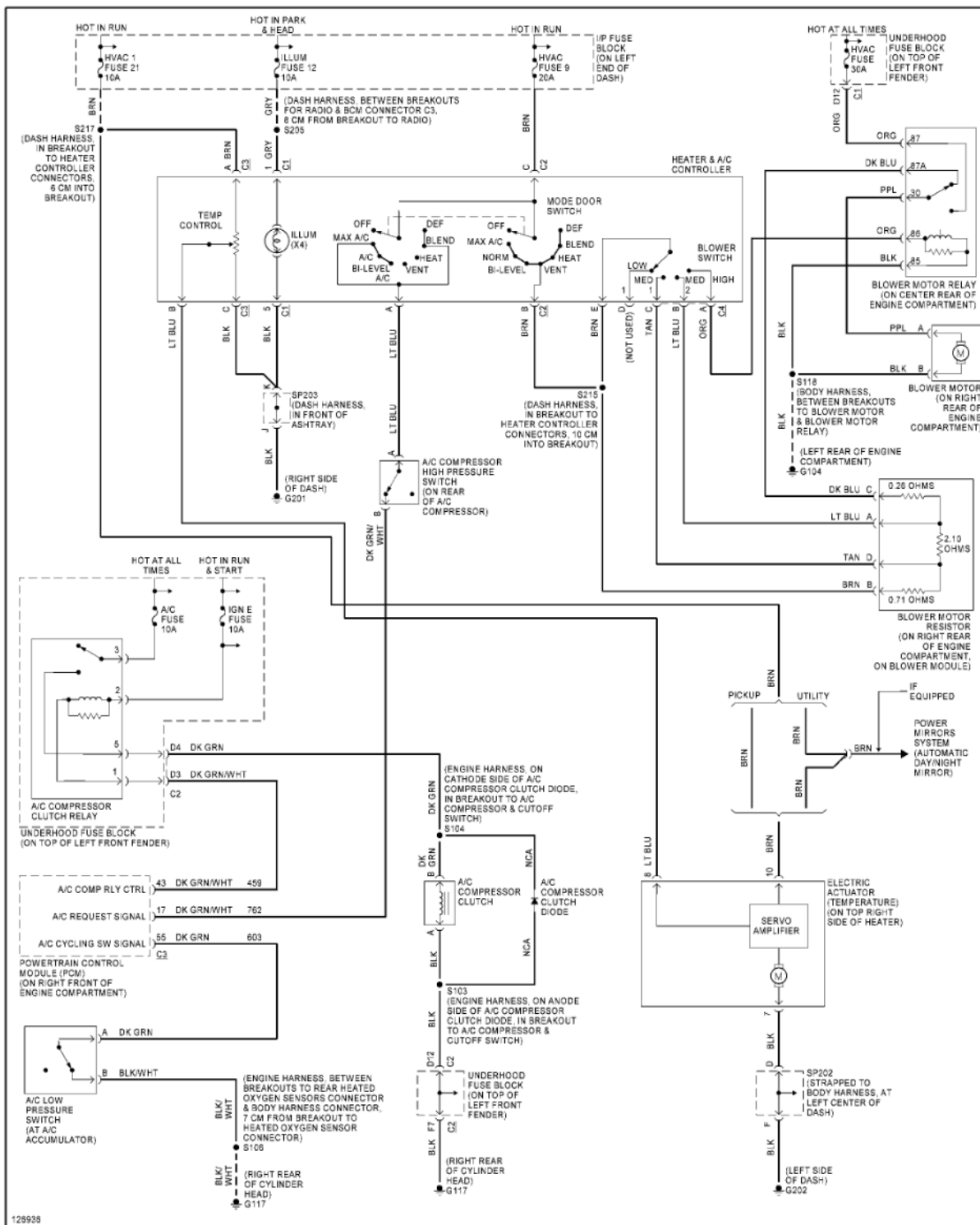

Fig. 5: 4.3L VIN W, Manual A/C Circuit

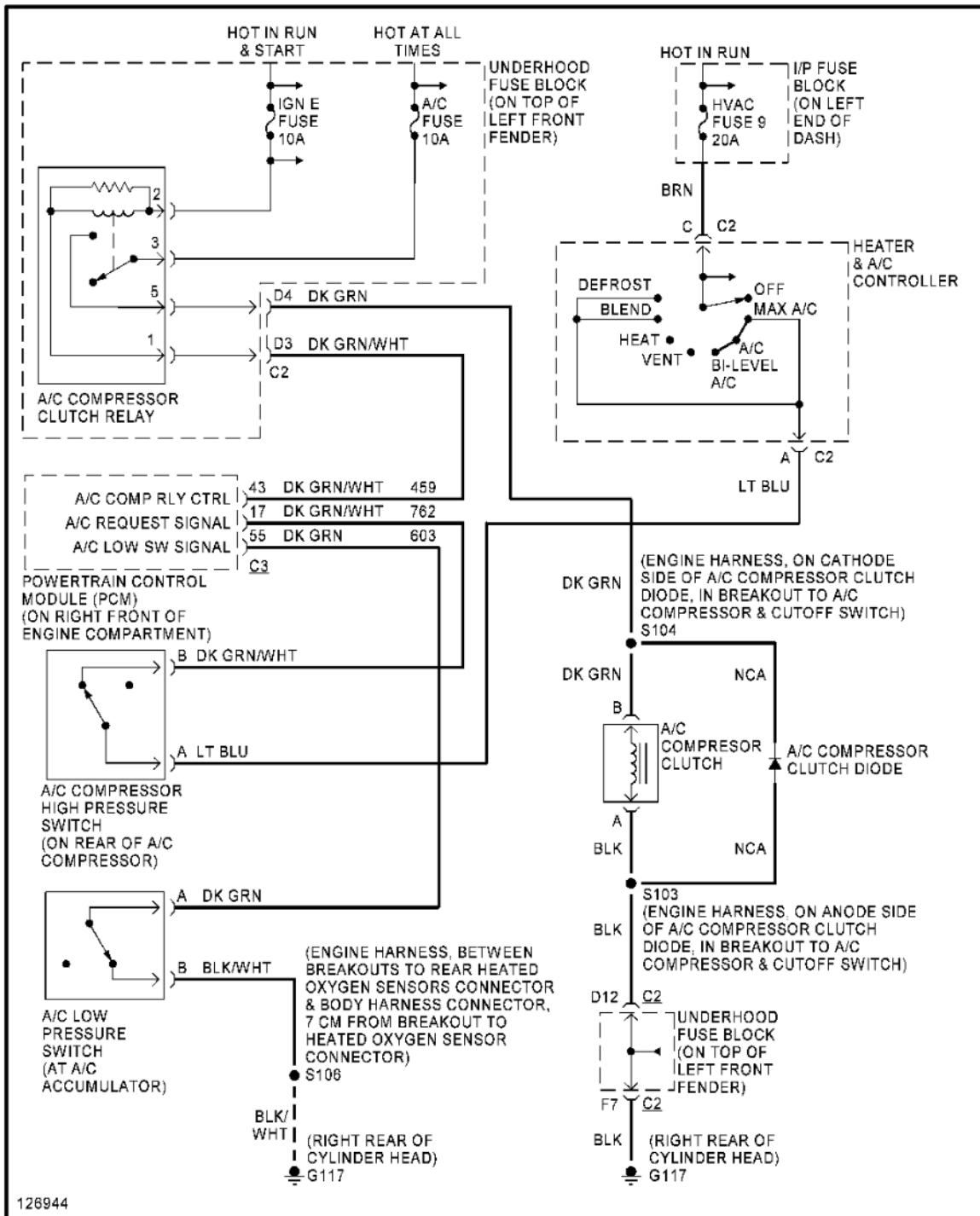

Fig. 6: 4.3L VIN X, Compressor Circuit, Manual A/C

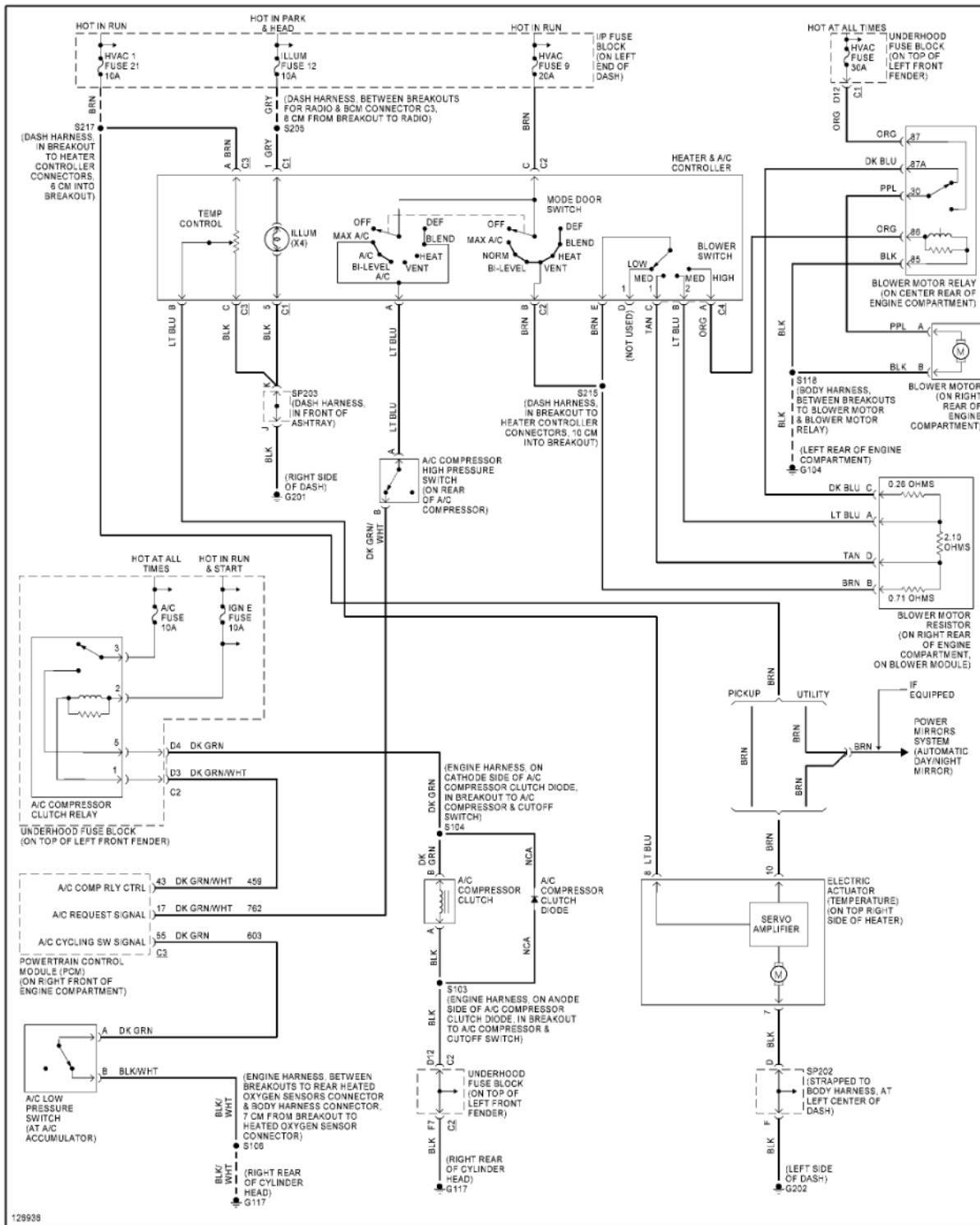

Fig. 7: 4.3L VIN X, Manual A/C Circuit

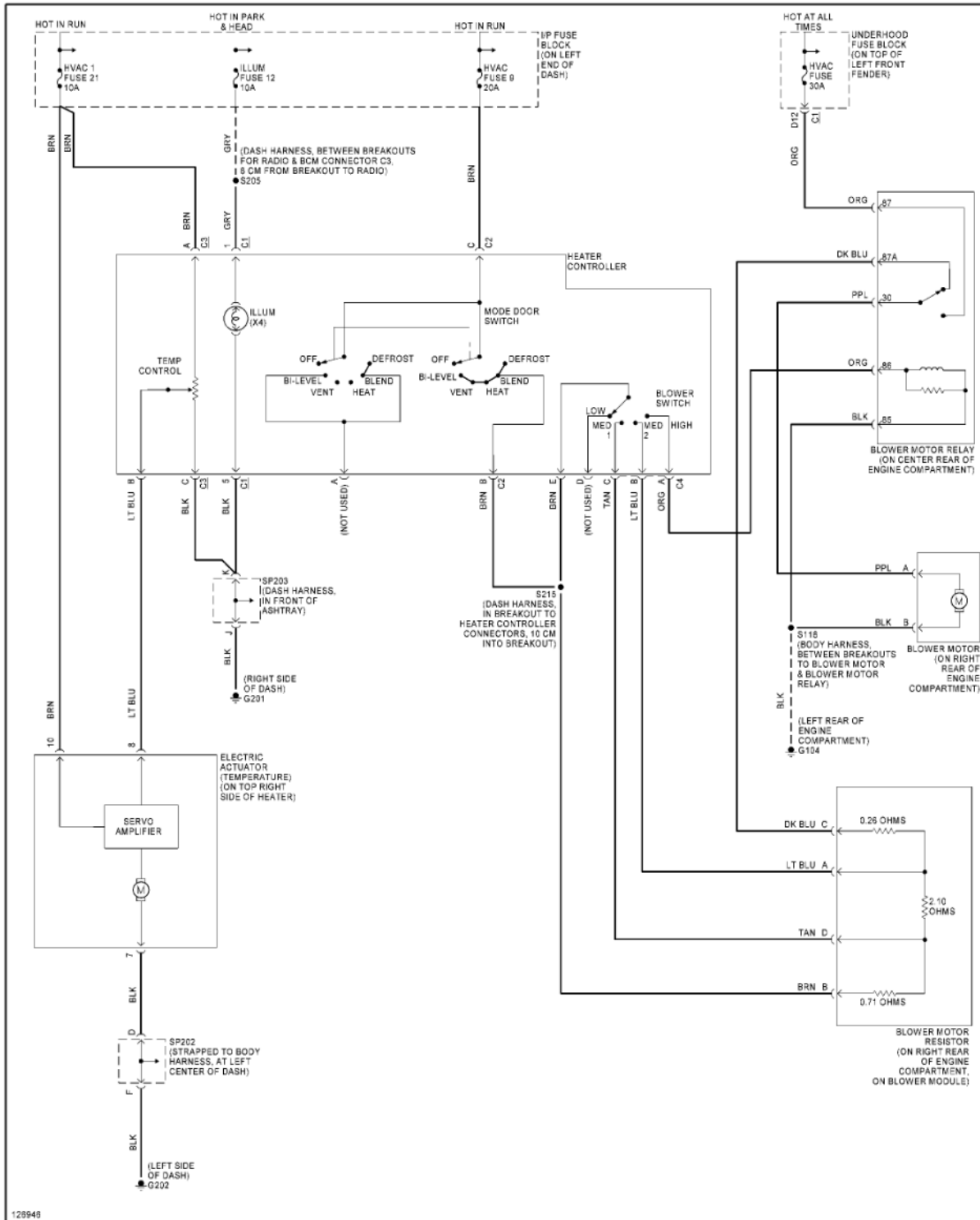

Fig. 8: Heater Circuit

ANTI-LOCK BRAKES

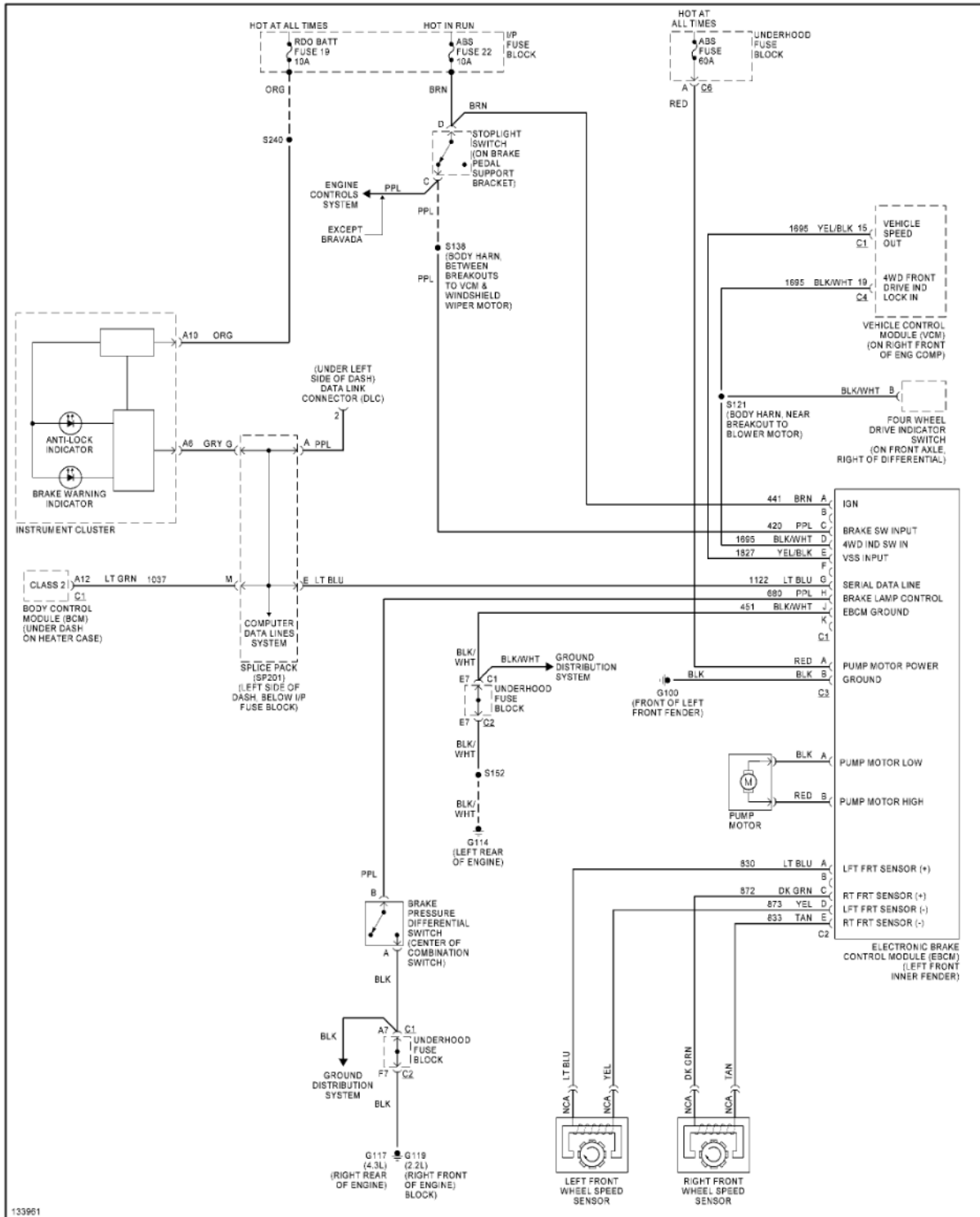

Fig. 9: Anti-lock Brake Circuits, 310 ABS

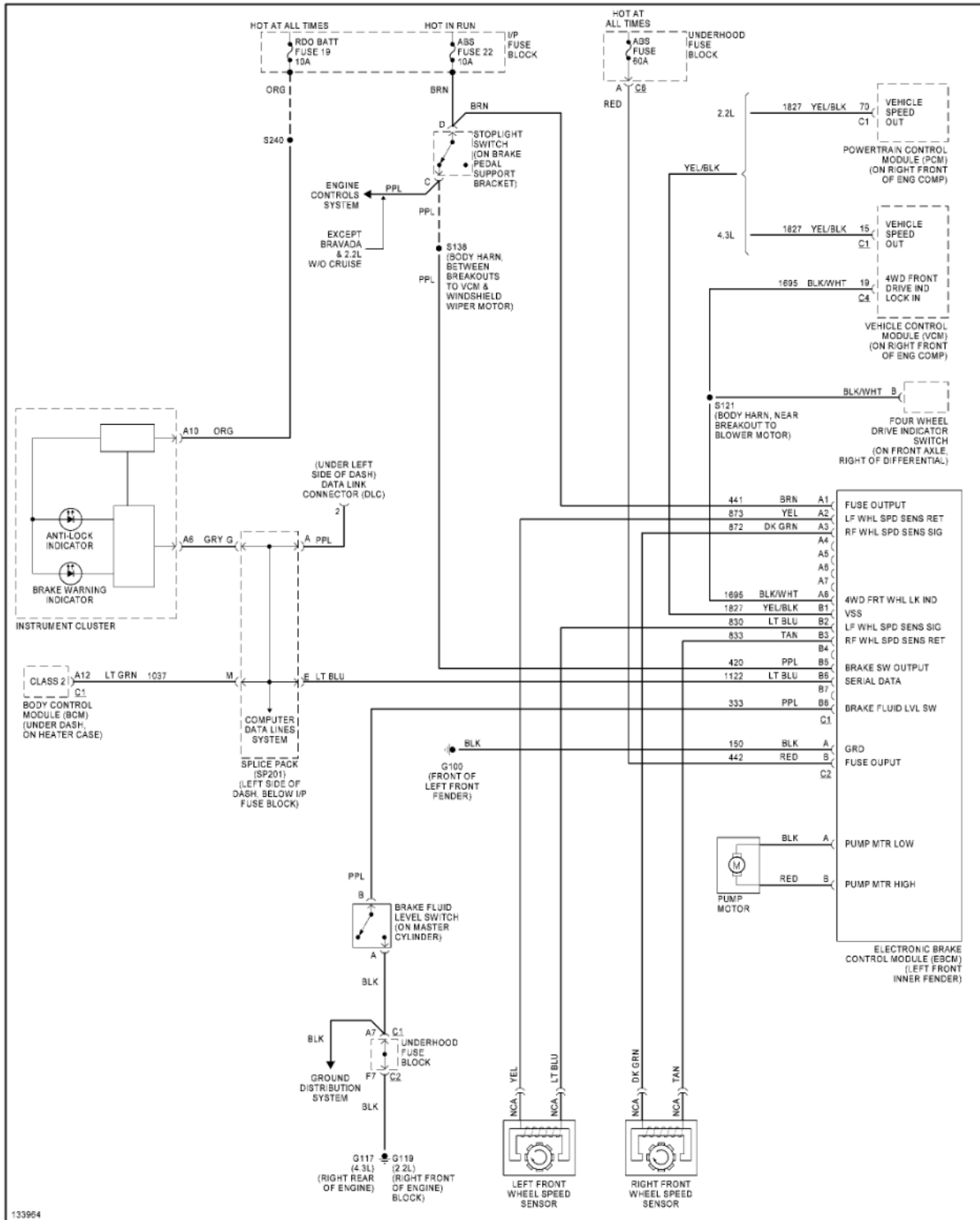

Fig. 10: Anti-lock Brake Circuits, 325 ABS

ANTI-THEFT

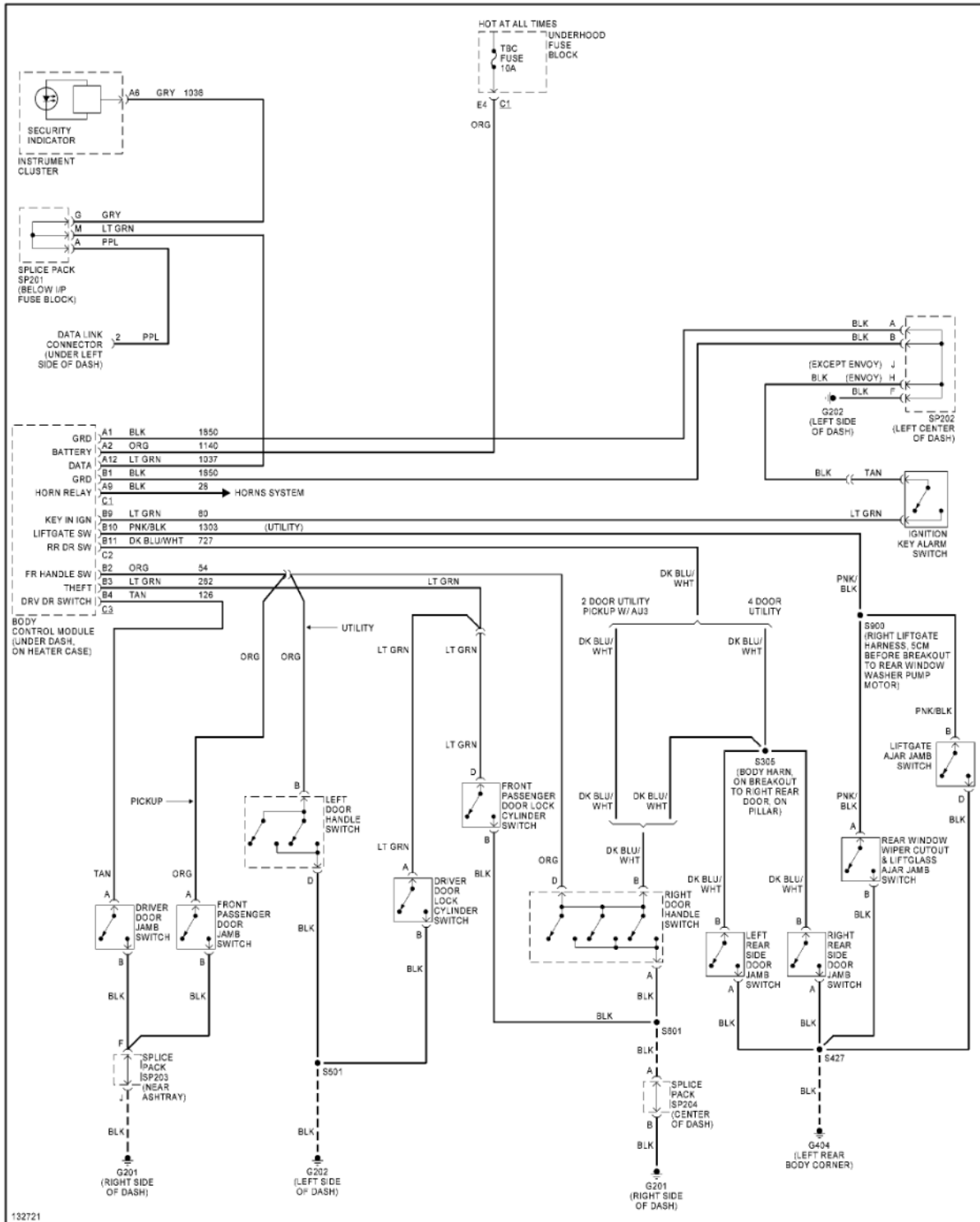

Fig. 11: Forced Entry Circuit

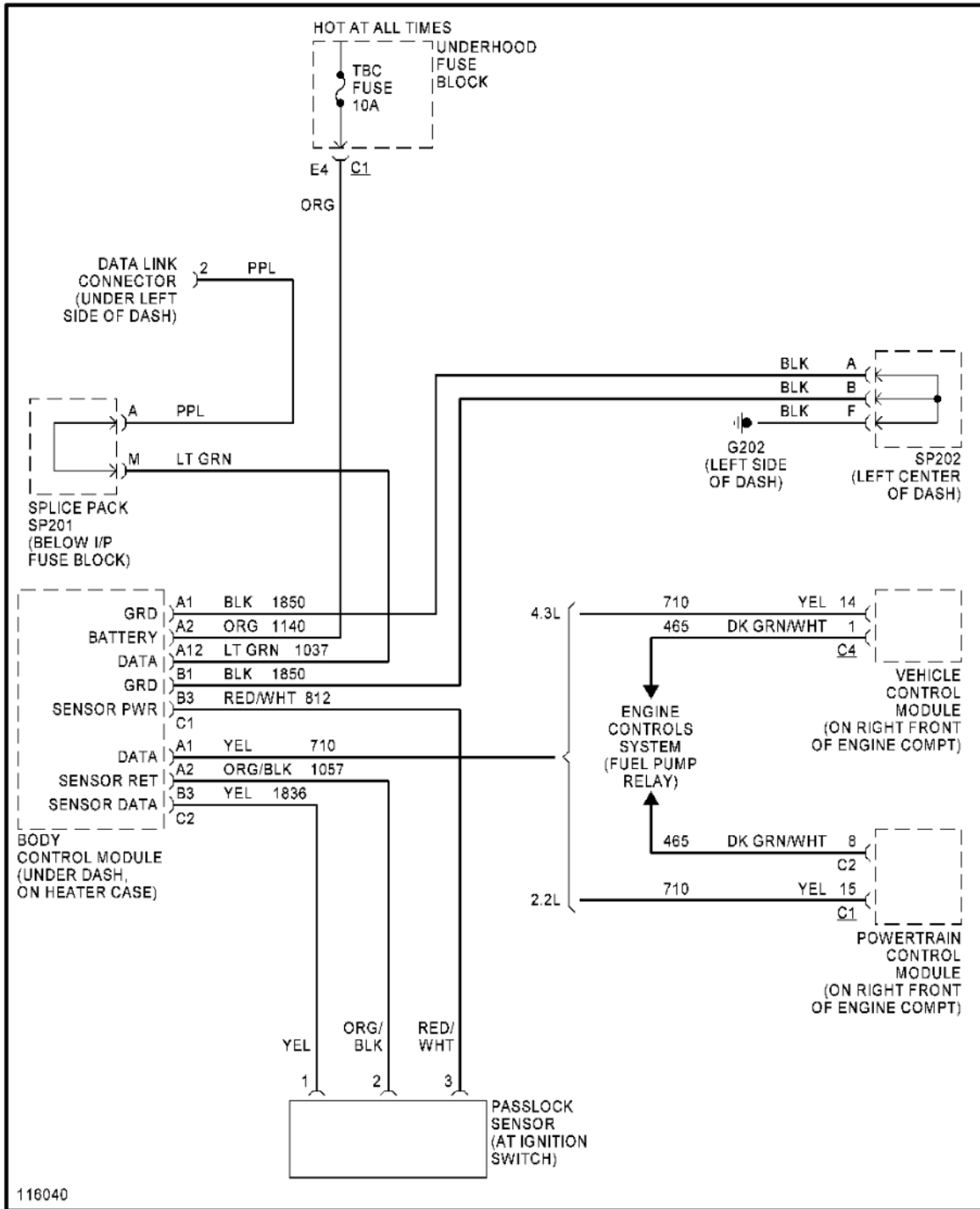

Fig. 12: Pass-Key Circuit

BODY COMPUTER

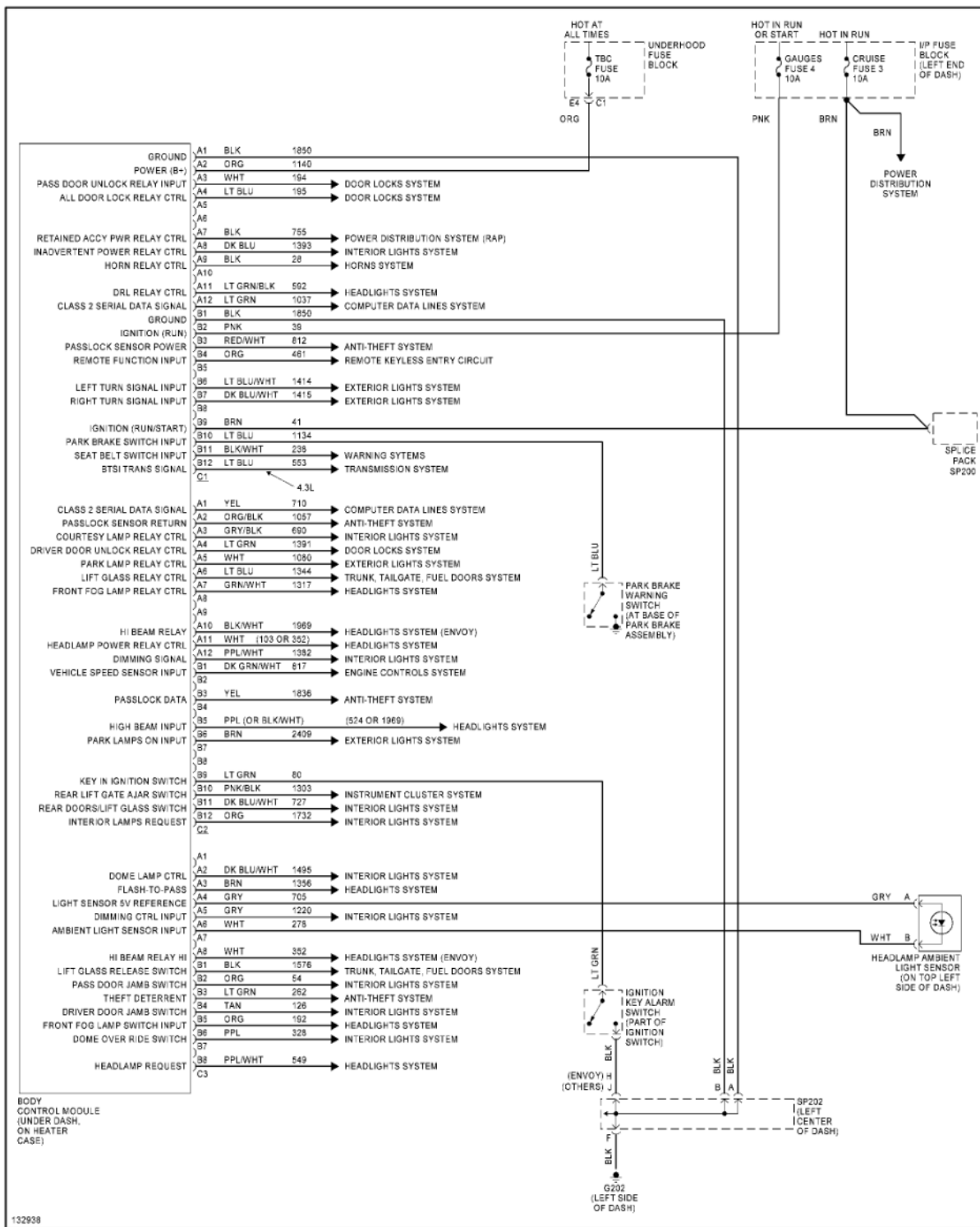

Fig. 13: Body Computer Circuits

COMPUTER DATA LINES

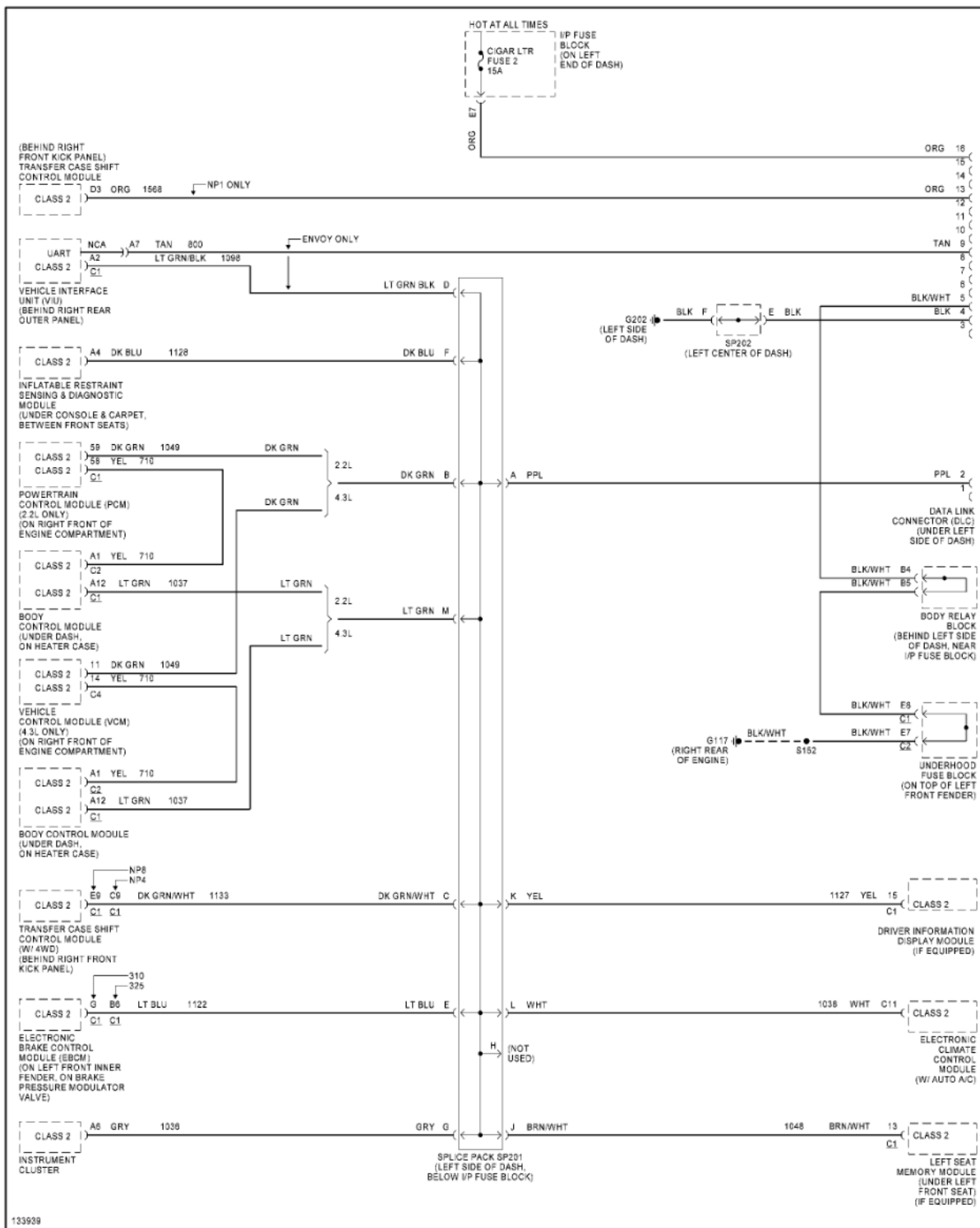

Fig. 14: Computer Data Lines

CRUISE CONTROL

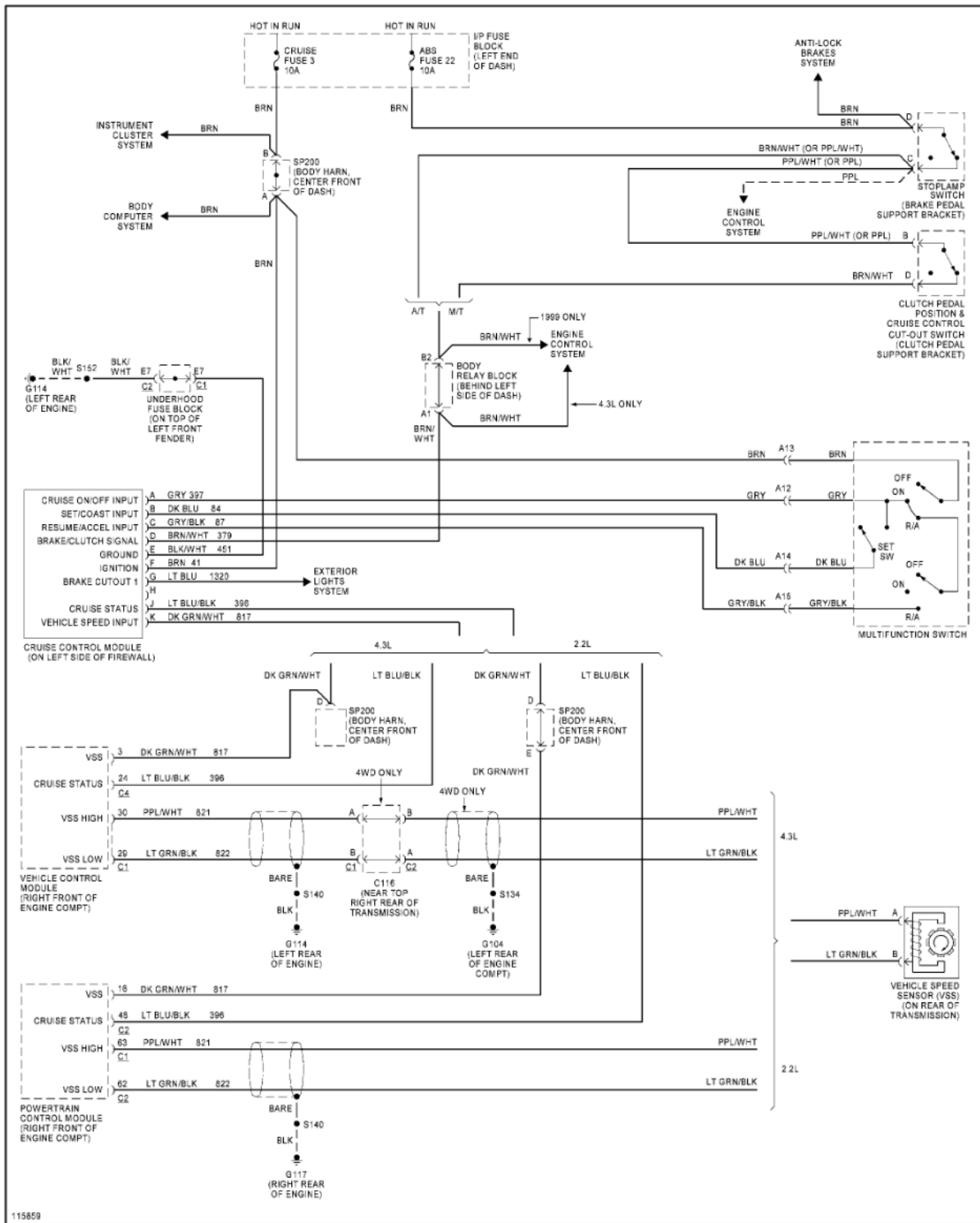

Fig. 15: Cruise Control Circuit

DEFOGGER

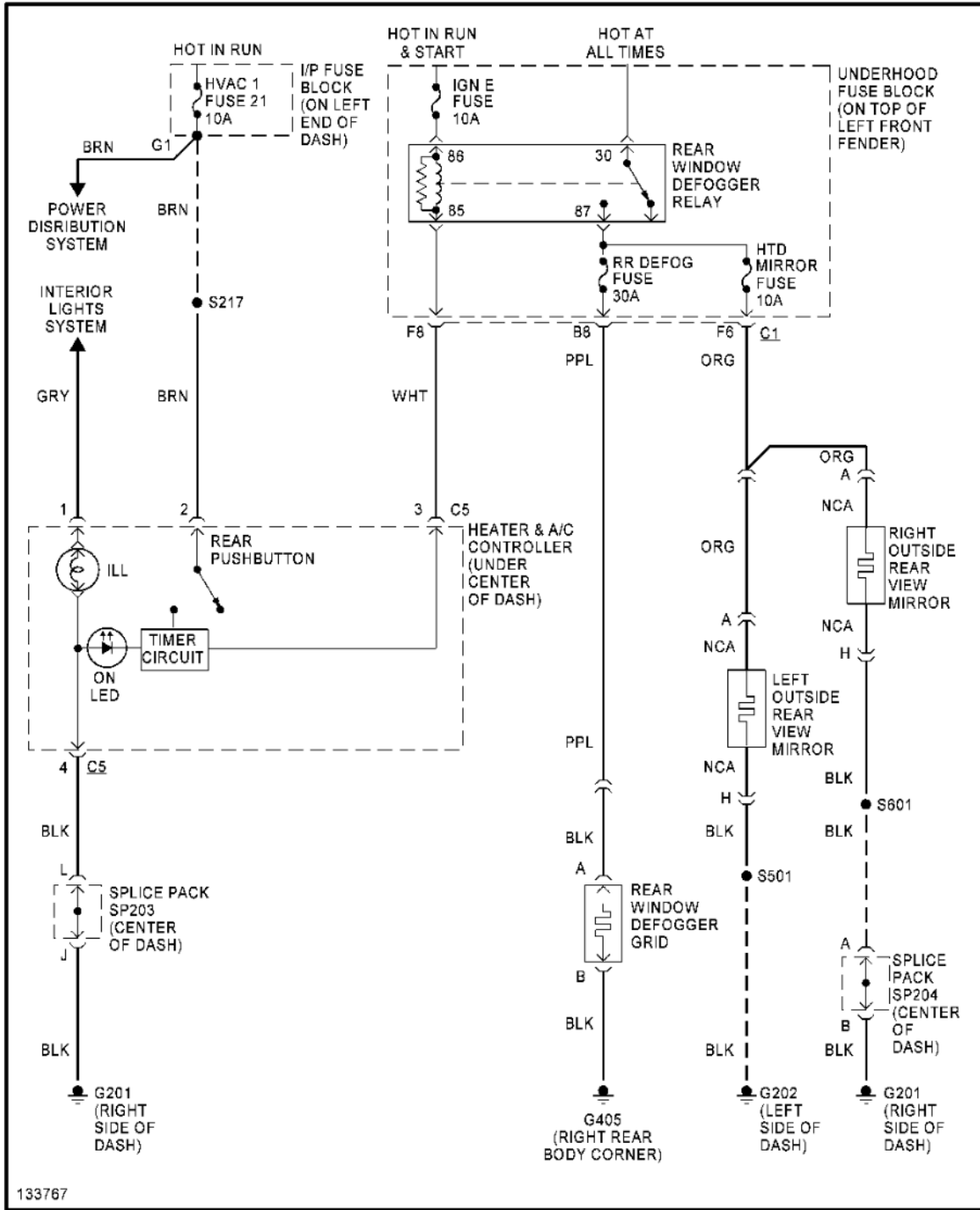

Fig. 16: Defogger Circuit

ENGINE PERFORMANCE

2.2L

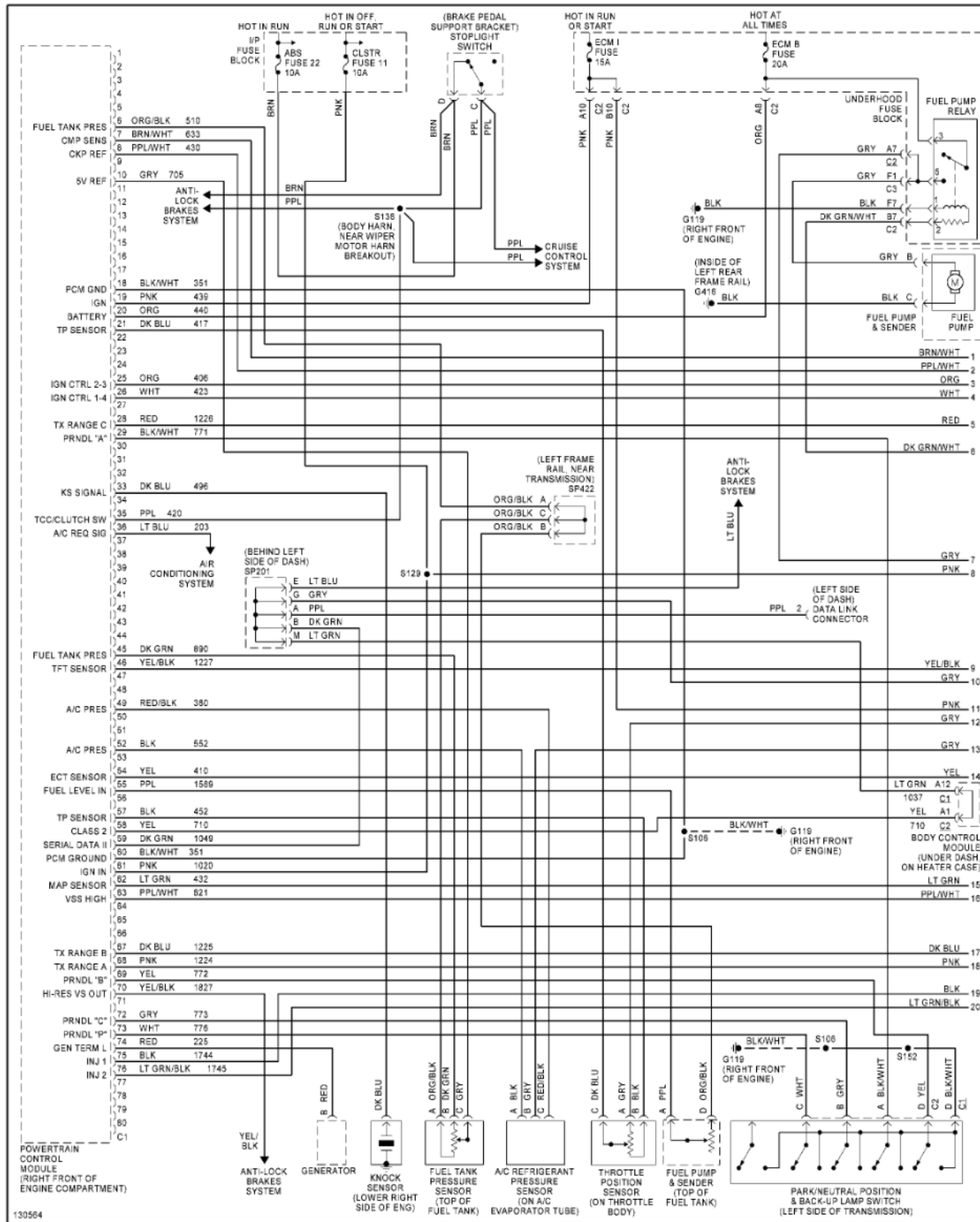

Fig. 17: 2.2L VIN 4, Engine Performance Circuits (1 of 3)

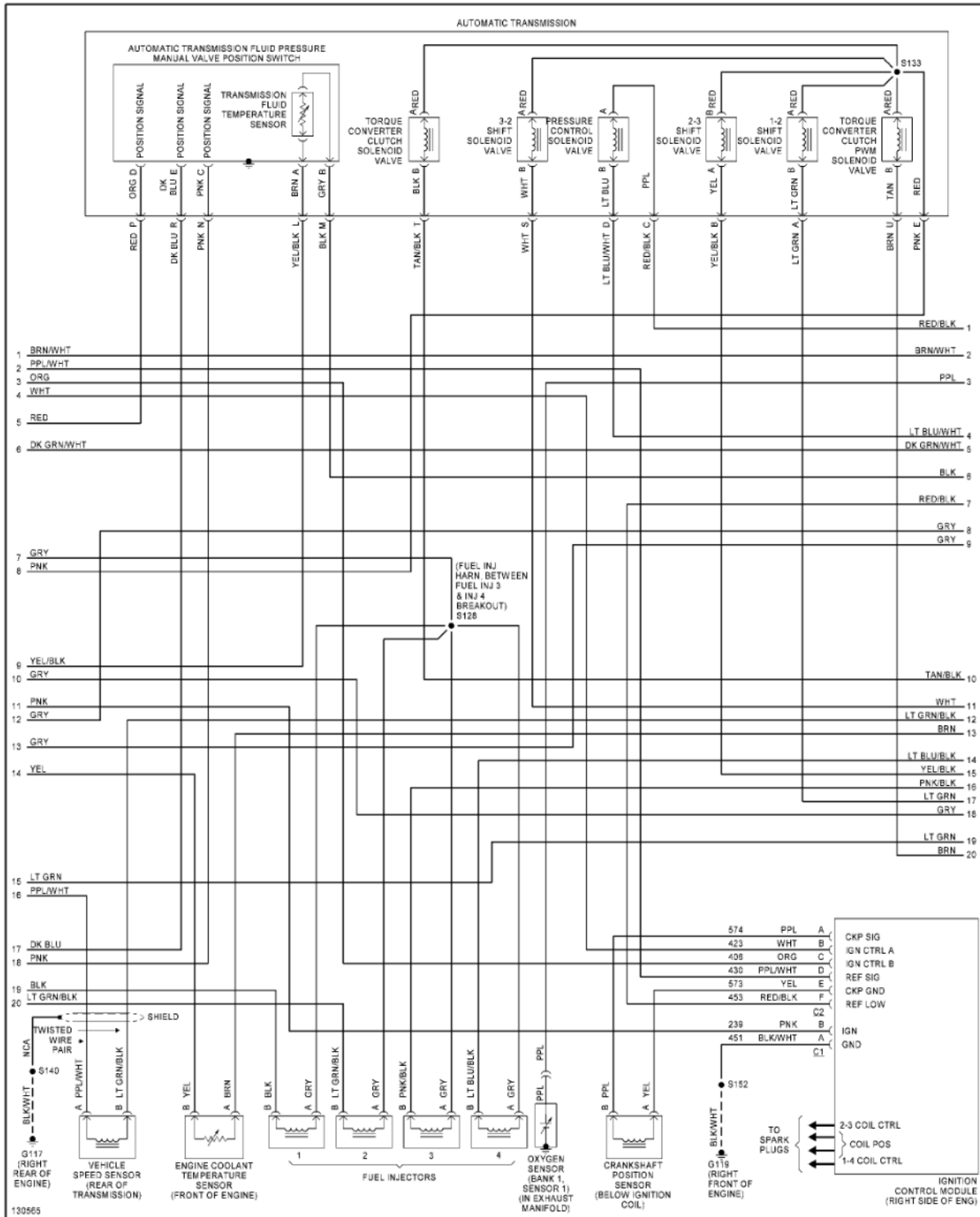

Fig. 18: 2.2L VIN 4, Engine Performance Circuits (2 of 3)

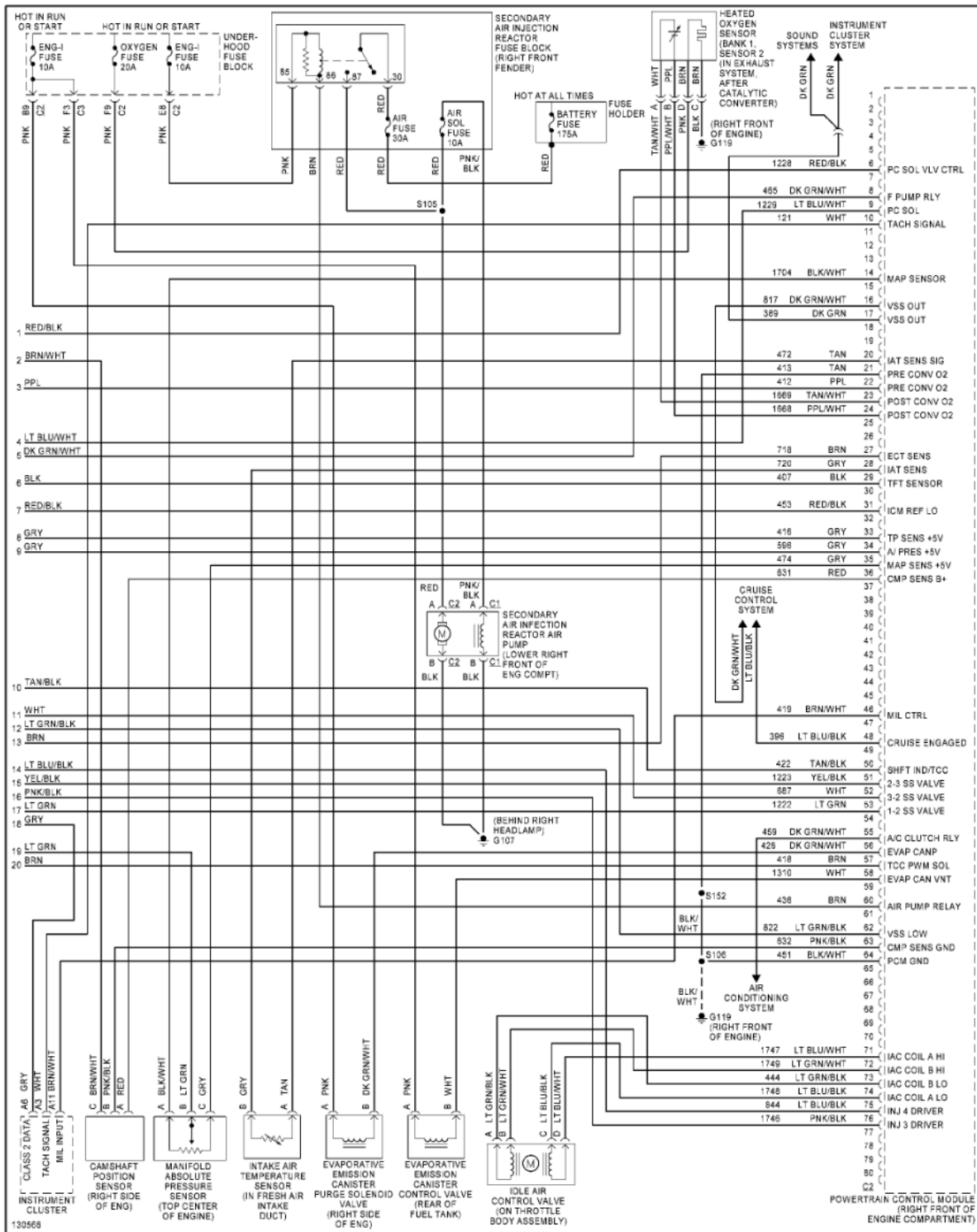

Fig. 19: 2.2L VIN 4, Engine Performance Circuits (3 of 3)

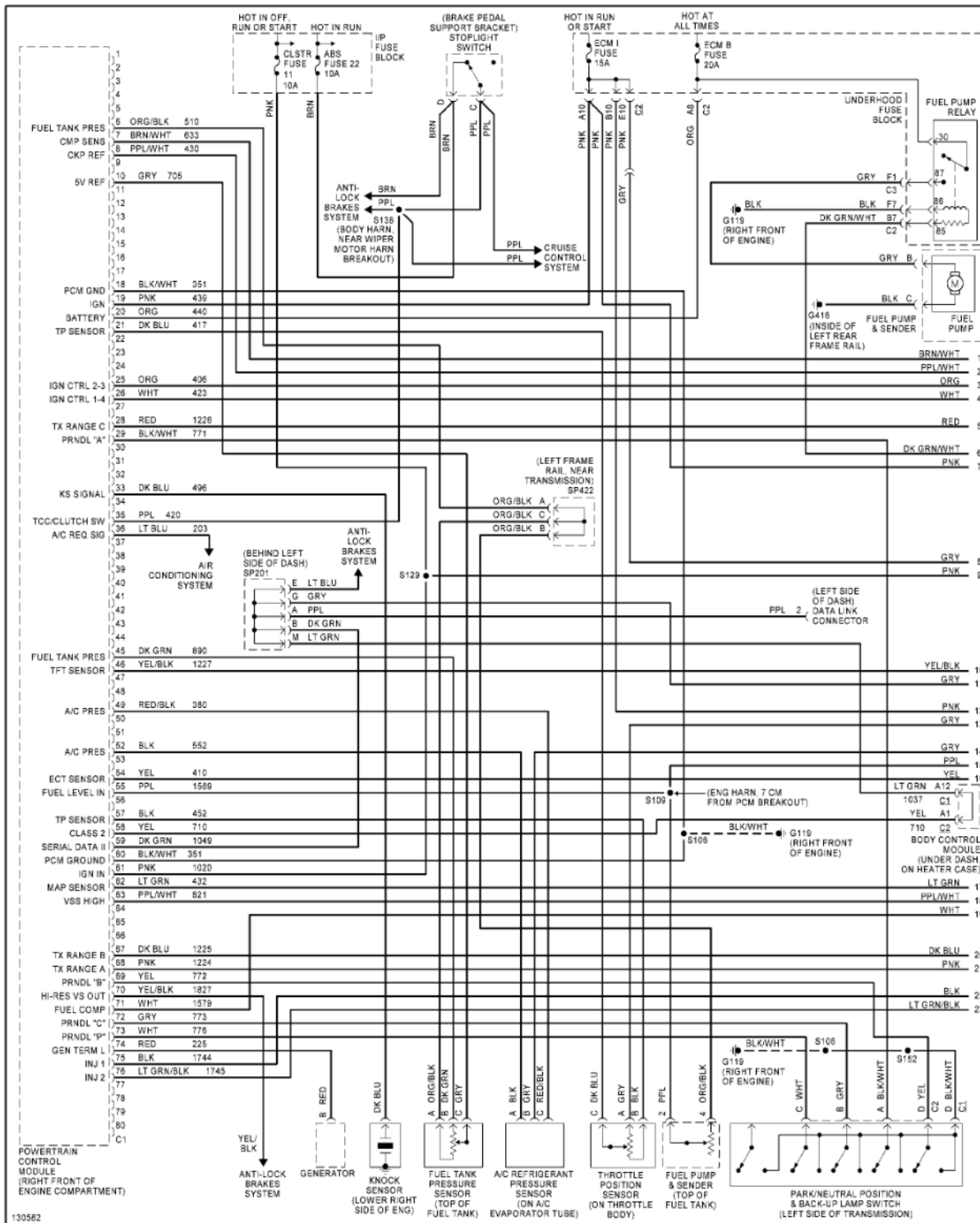

Fig. 20: 2.2L VIN 5, Engine Performance Circuits (1 of 3)

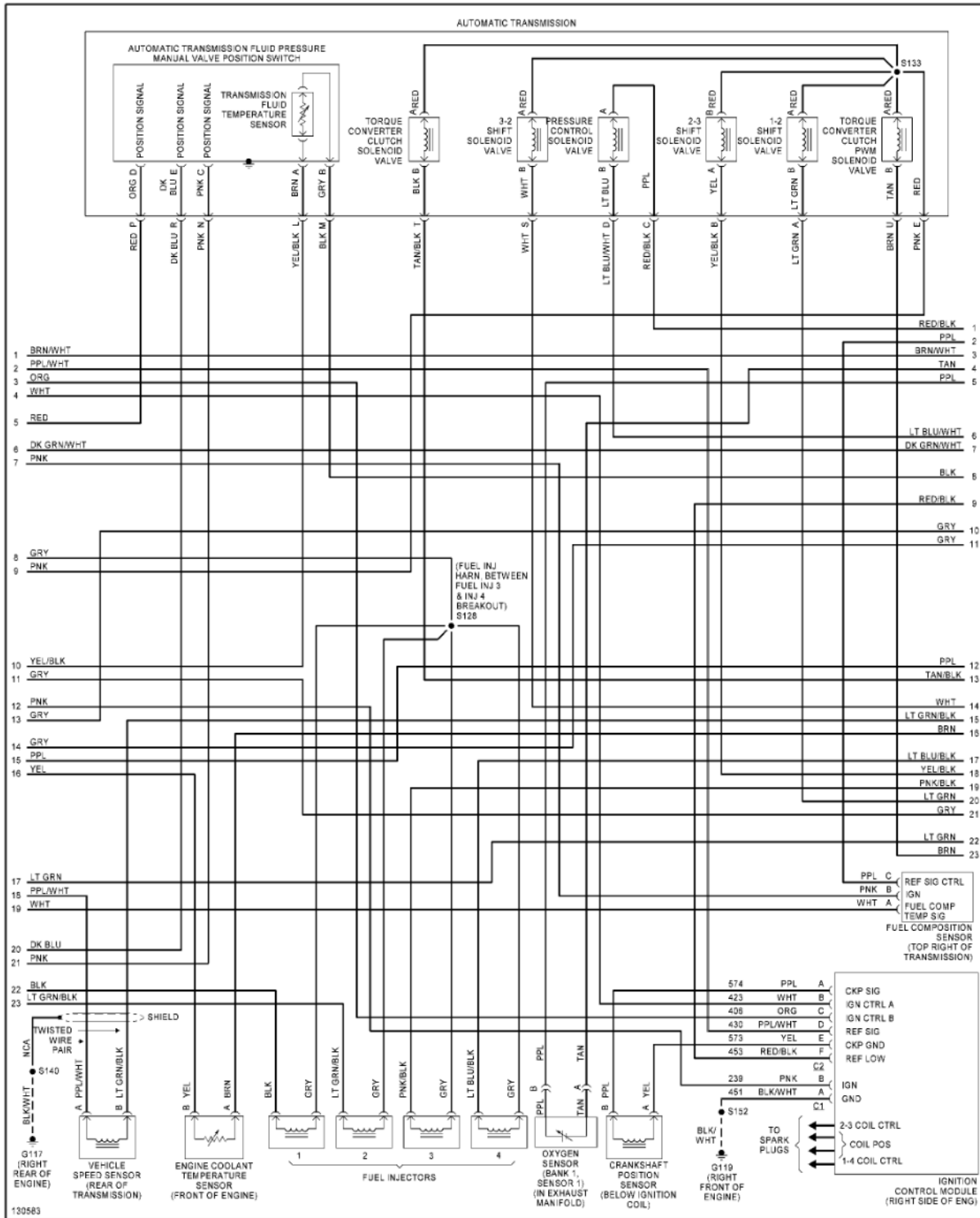

Fig. 21: 2.2L VIN 5, Engine Performance Circuits (2 of 3)

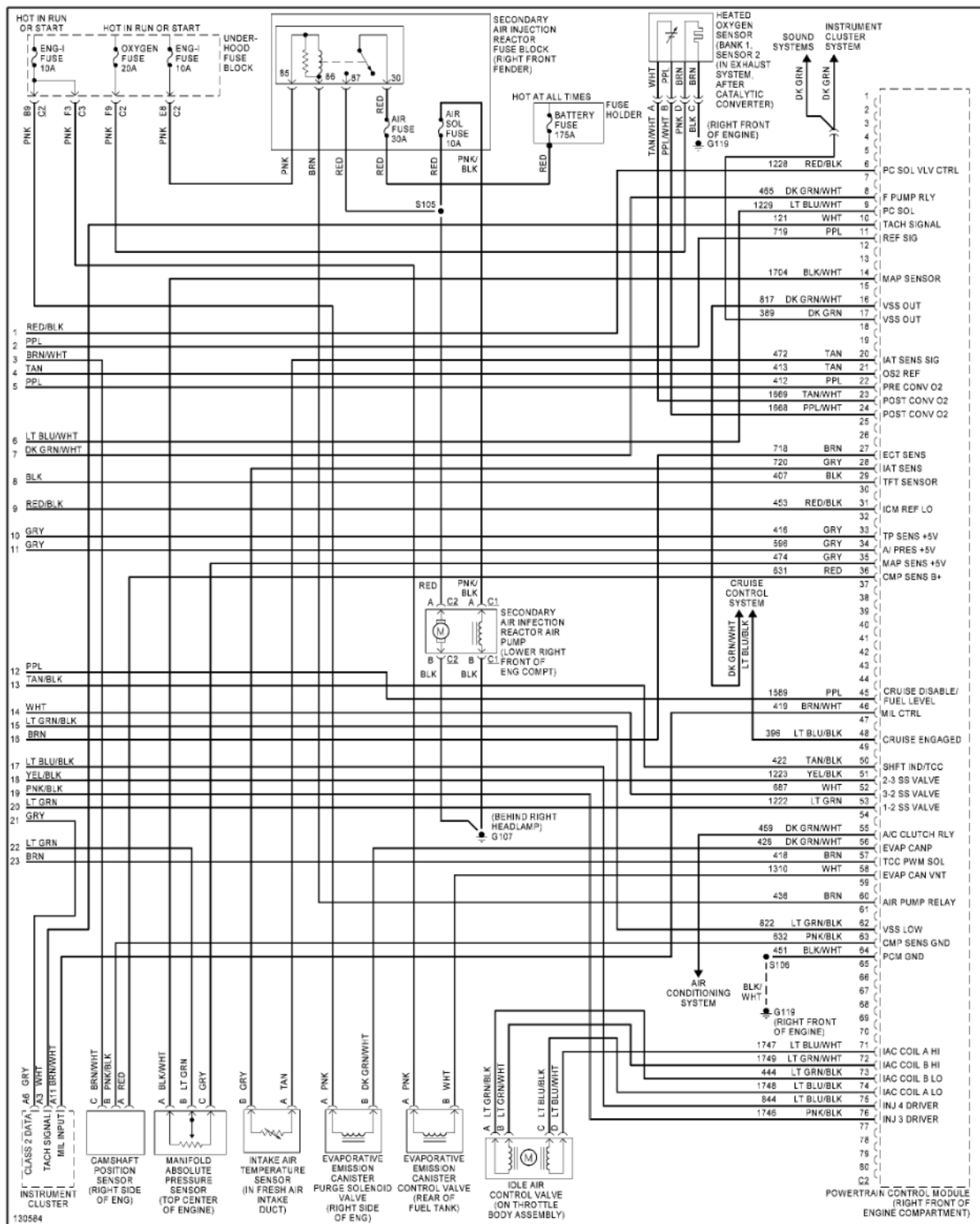

Fig. 22: 2.2L VIN 5, Engine Performance Circuits (3 of 3)

4.3L

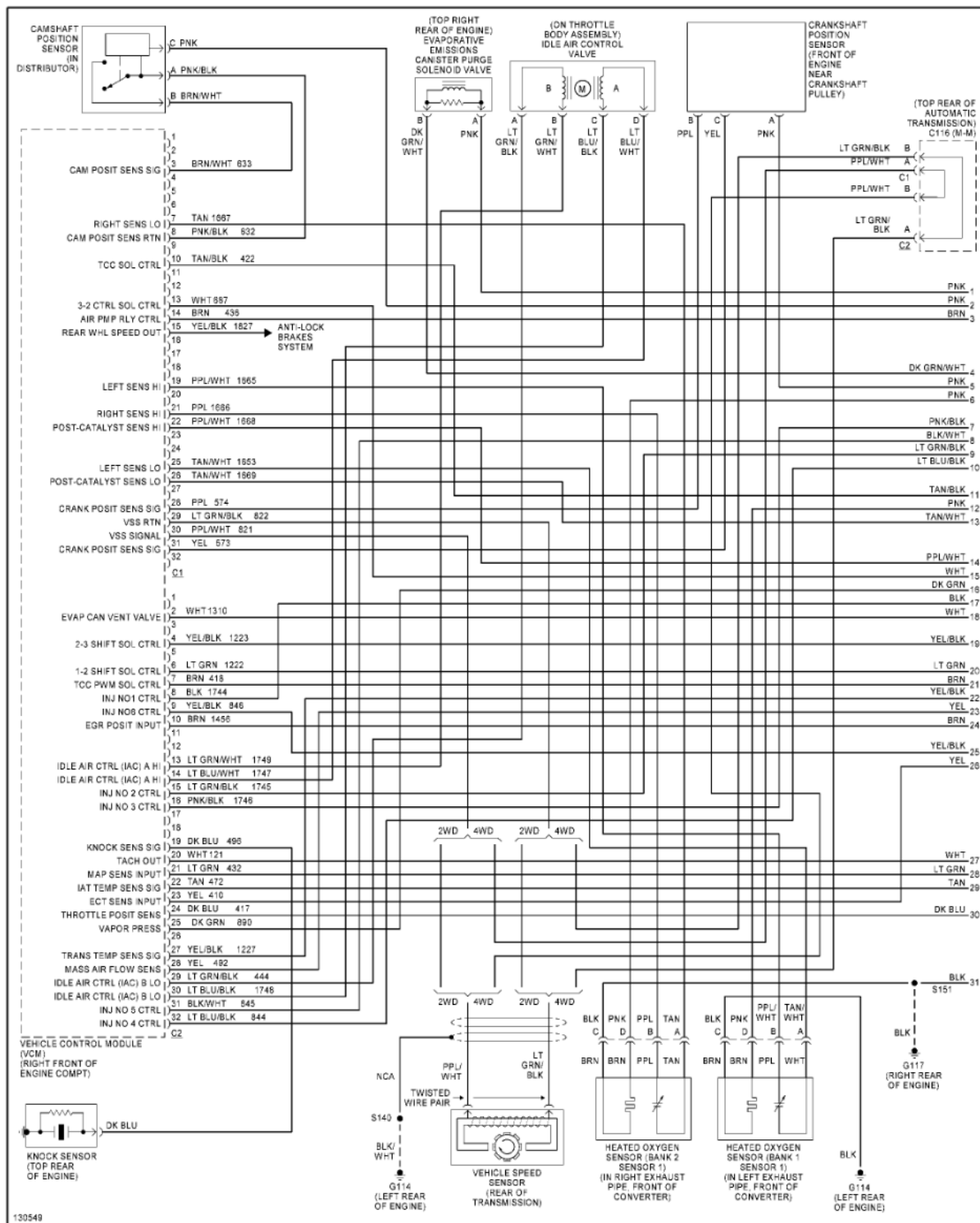

Fig. 23: 4.3L VIN W, Engine Performance Circuits (1 of 4)

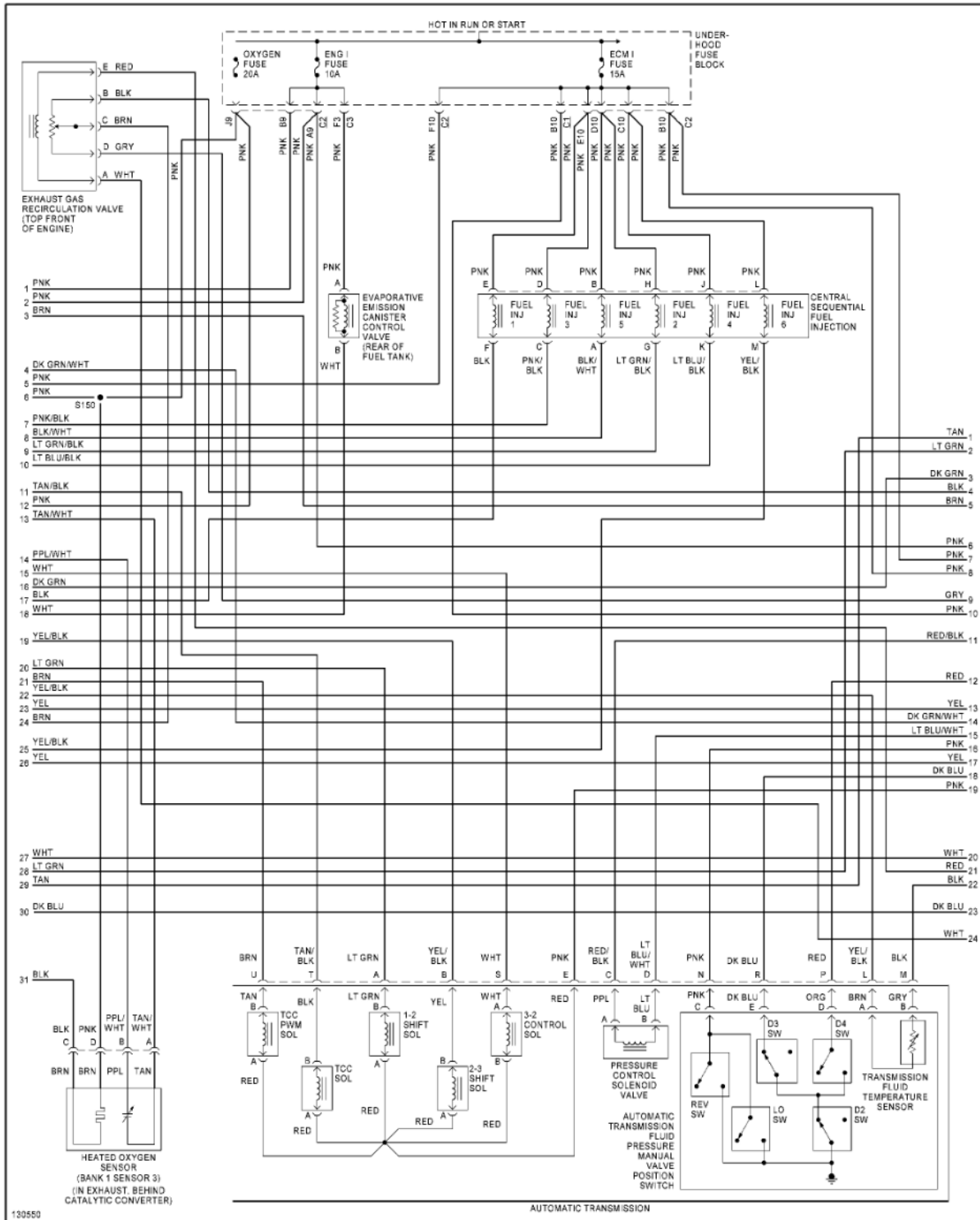

Fig. 24: 4.3L VIN W, Engine Performance Circuits (2 of 4)

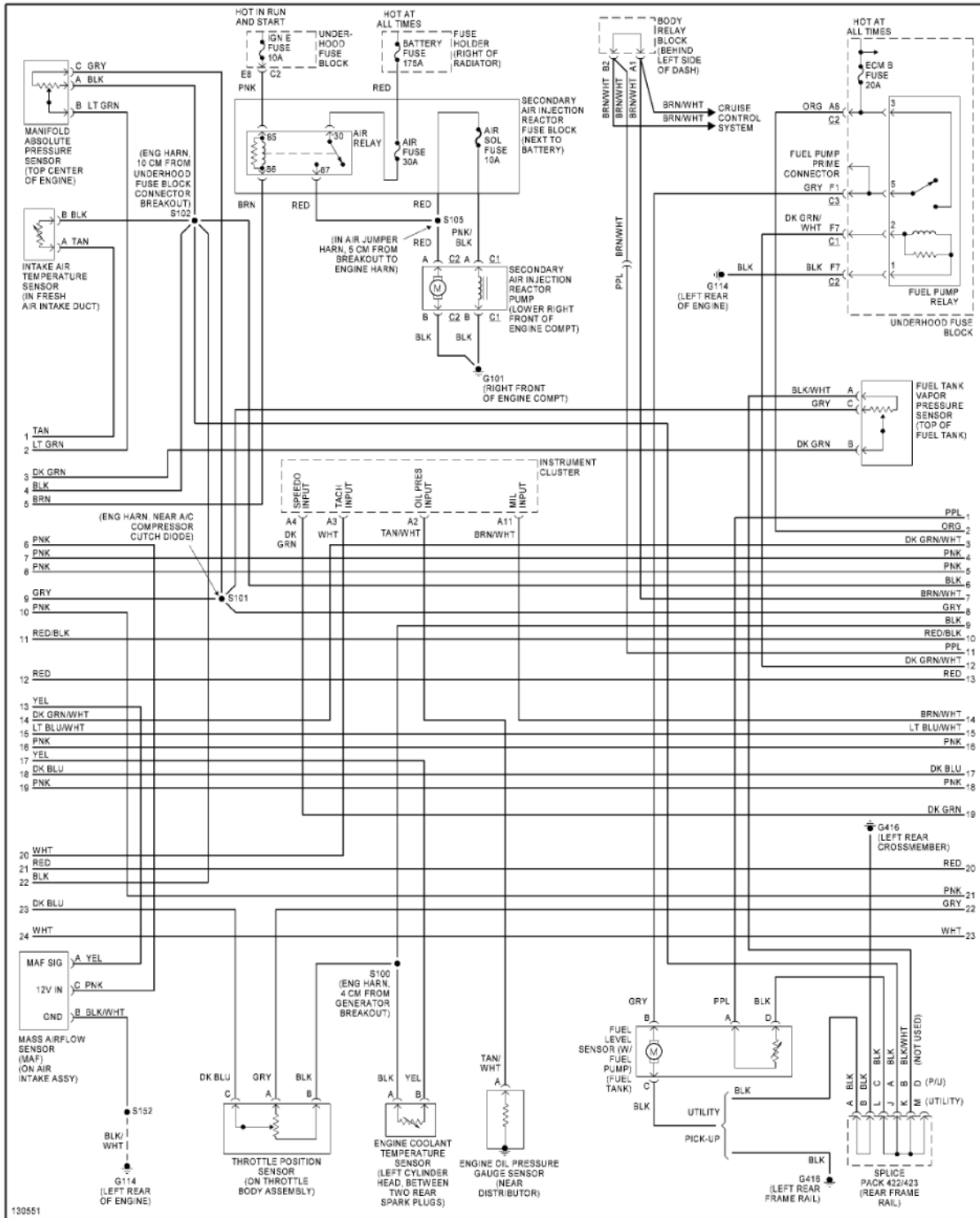

Fig. 25: 4.3L VIN W, Engine Performance Circuits (3 of 4)

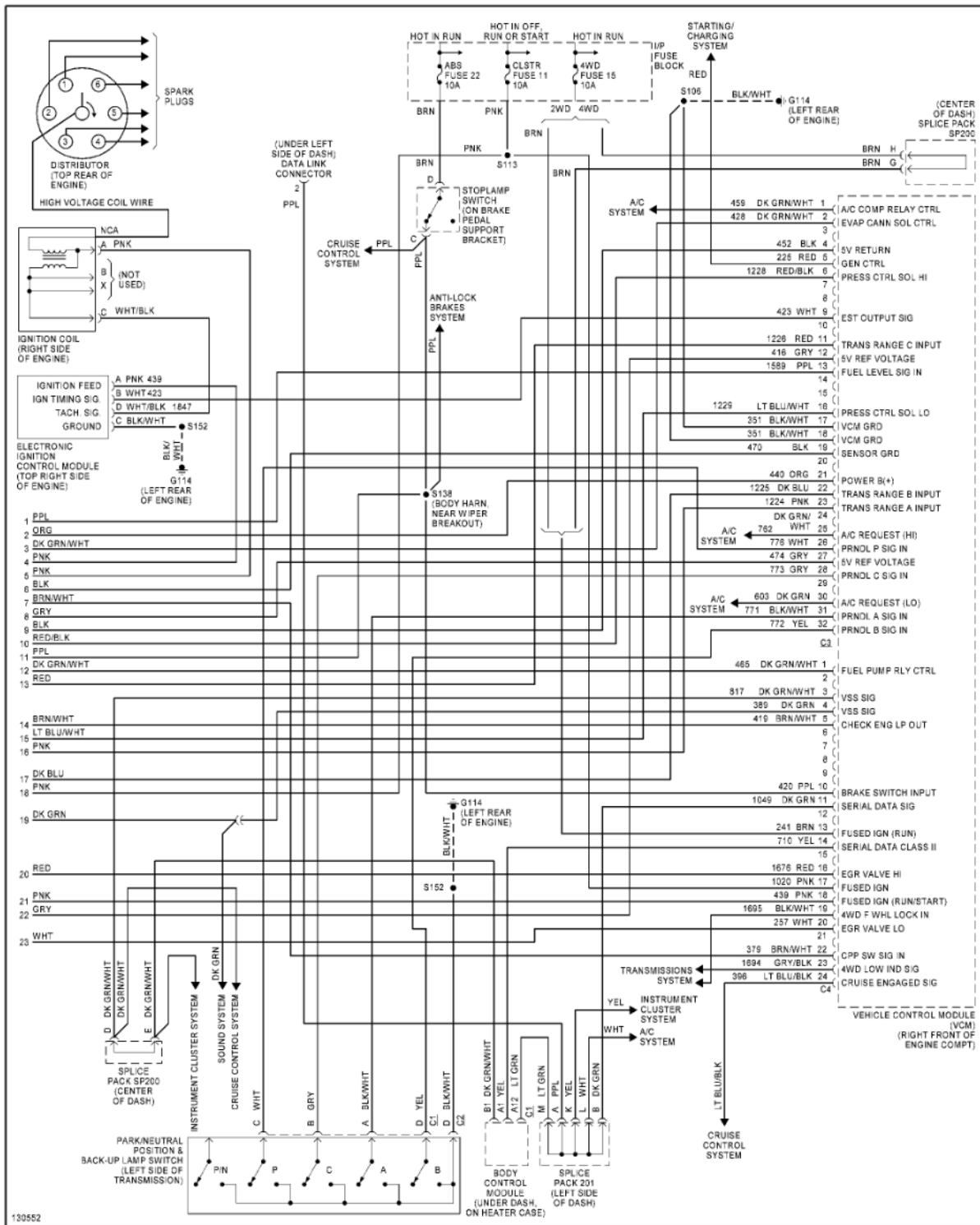

Fig. 26: 4.3L VIN W, Engine Performance Circuits (4 of 4)

EXTERIOR LIGHTS

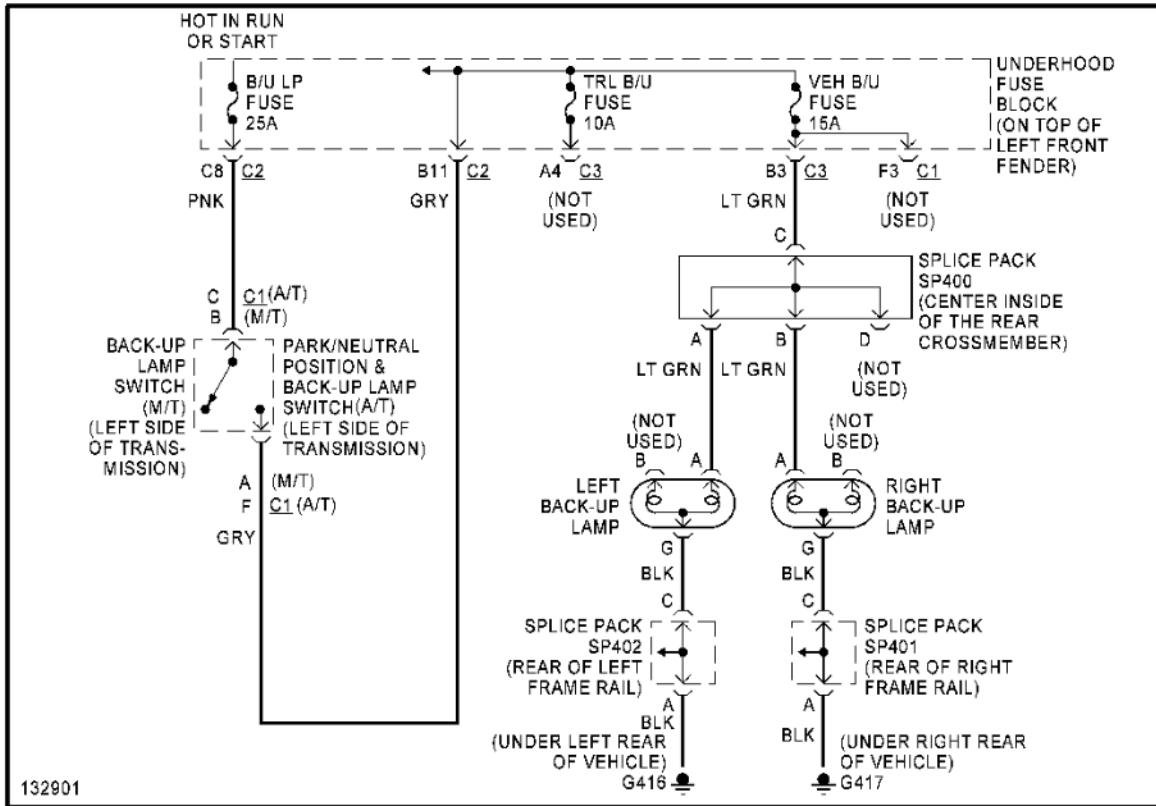

Fig. 27: Back-up Lamps Circuit

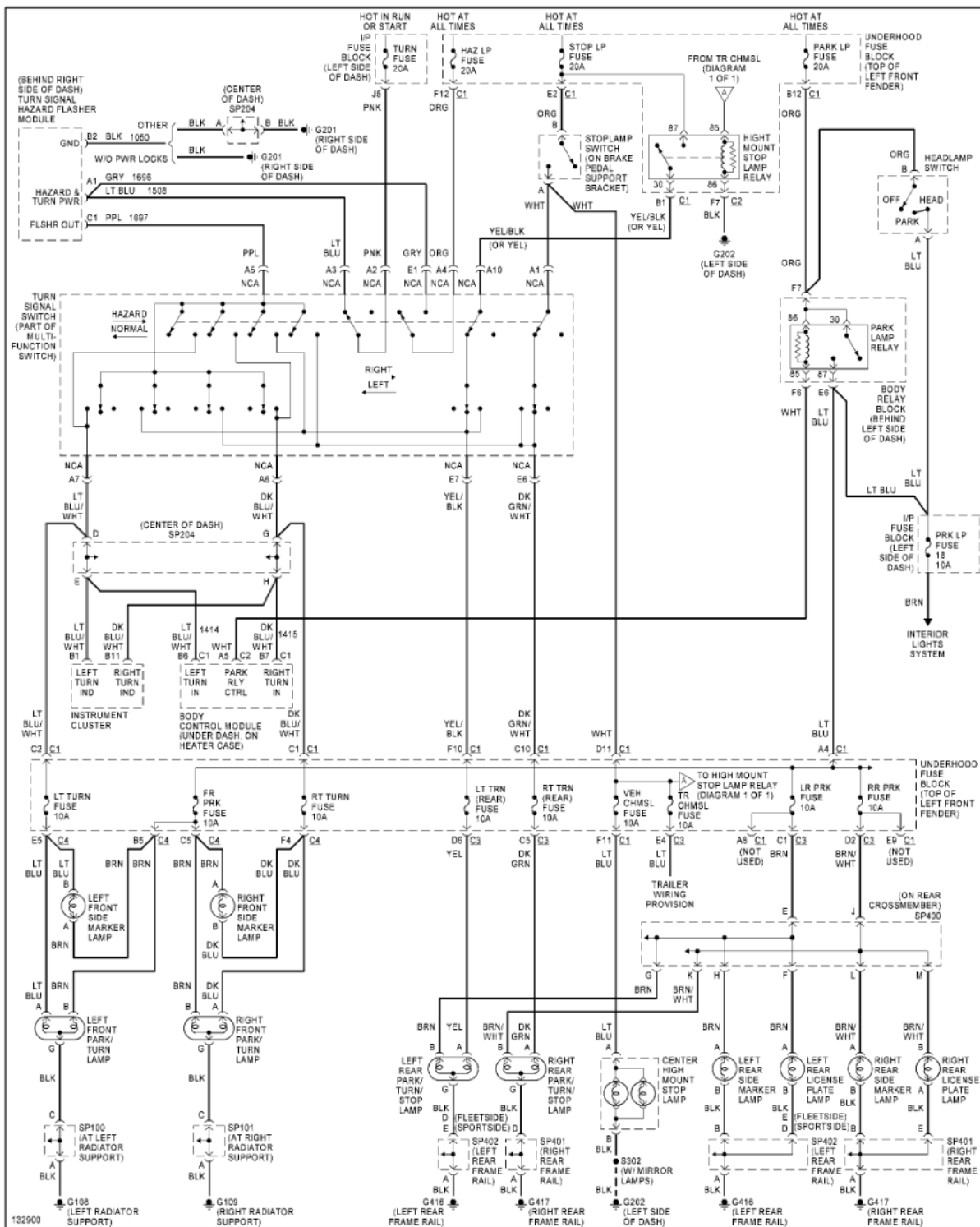

Fig. 28: Exterior Lamps Circuit

GROUND DISTRIBUTION

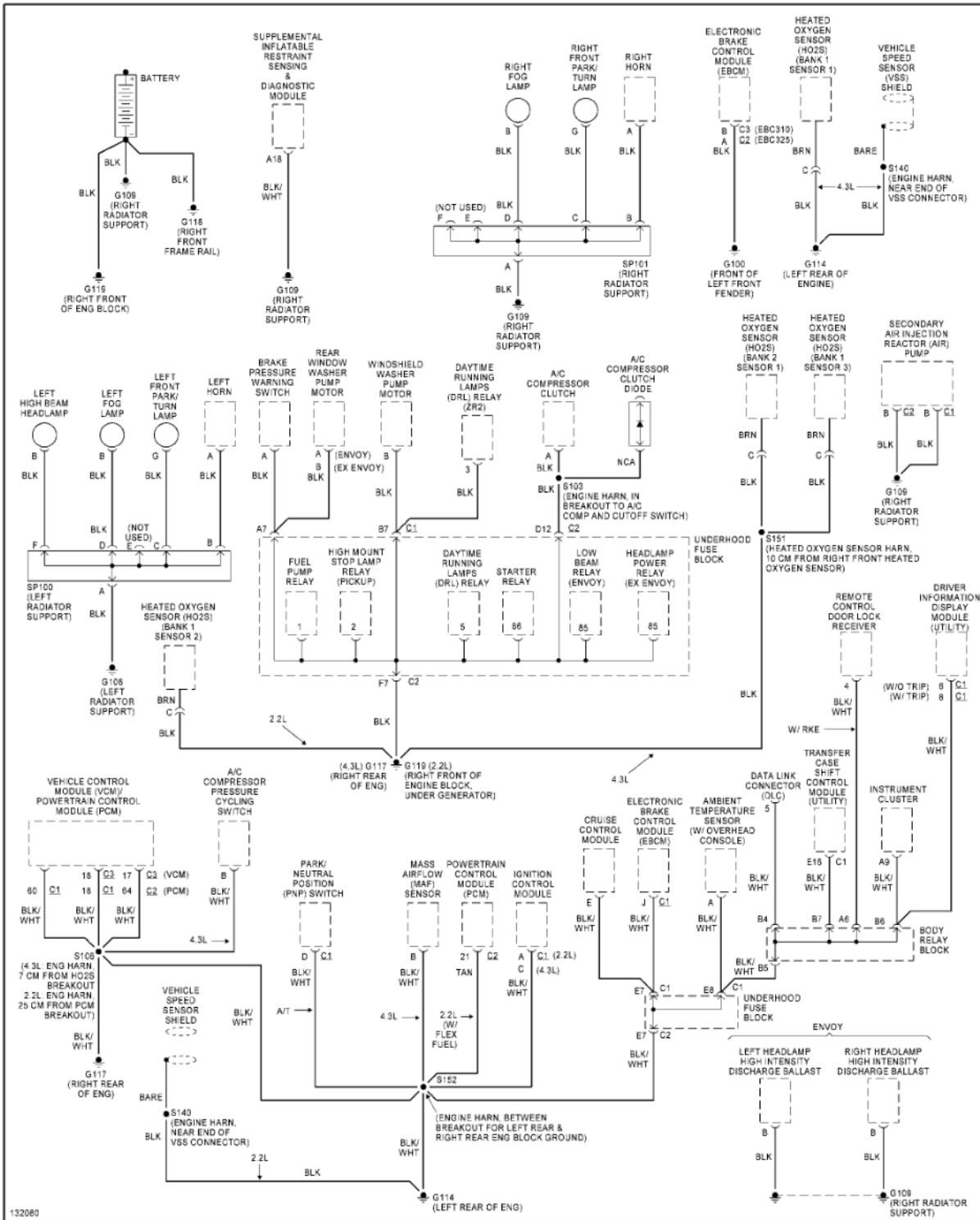

Fig. 29: Ground Distribution Circuit (1 of 3)

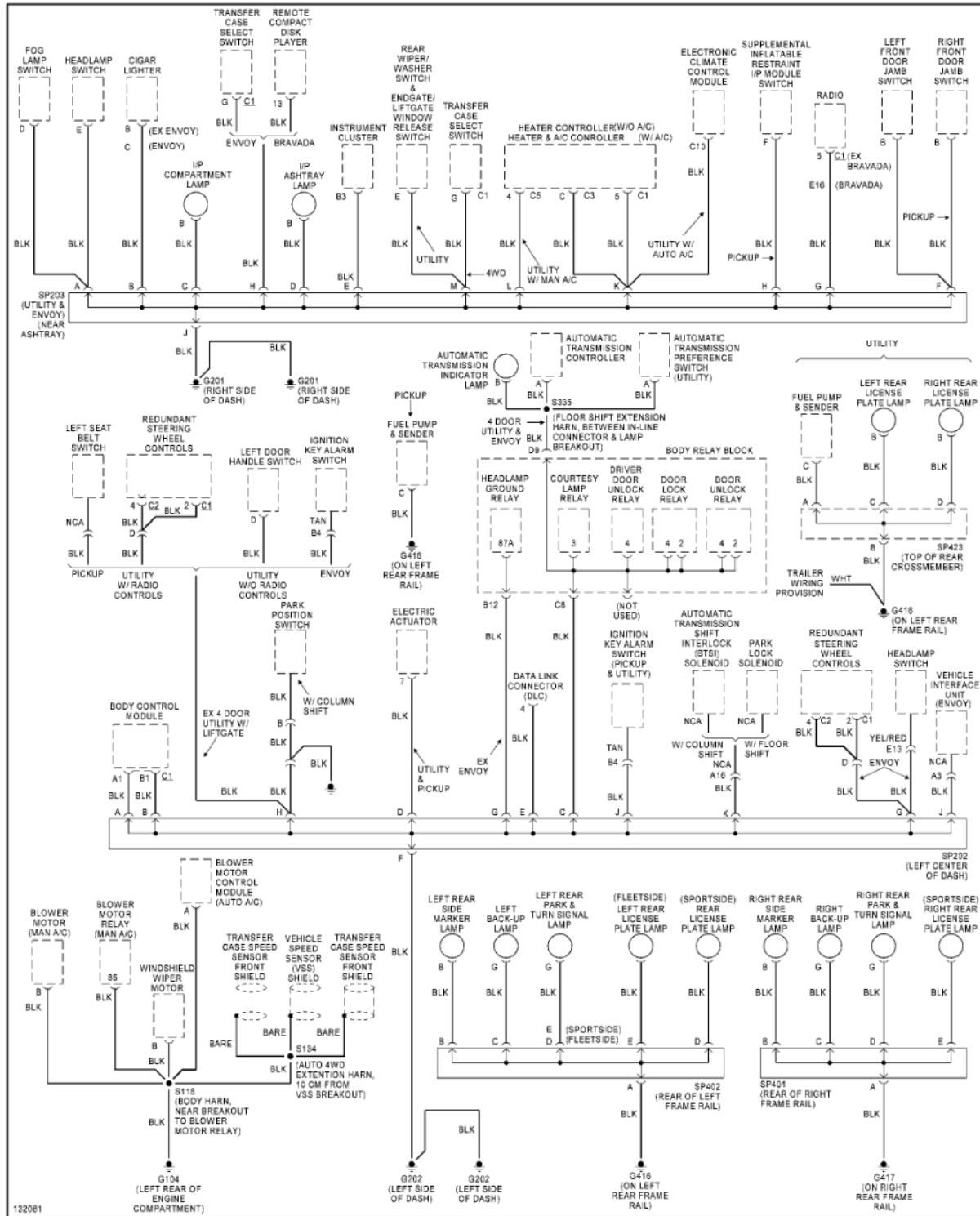

Fig. 30: Ground Distribution Circuit (2 of 3)

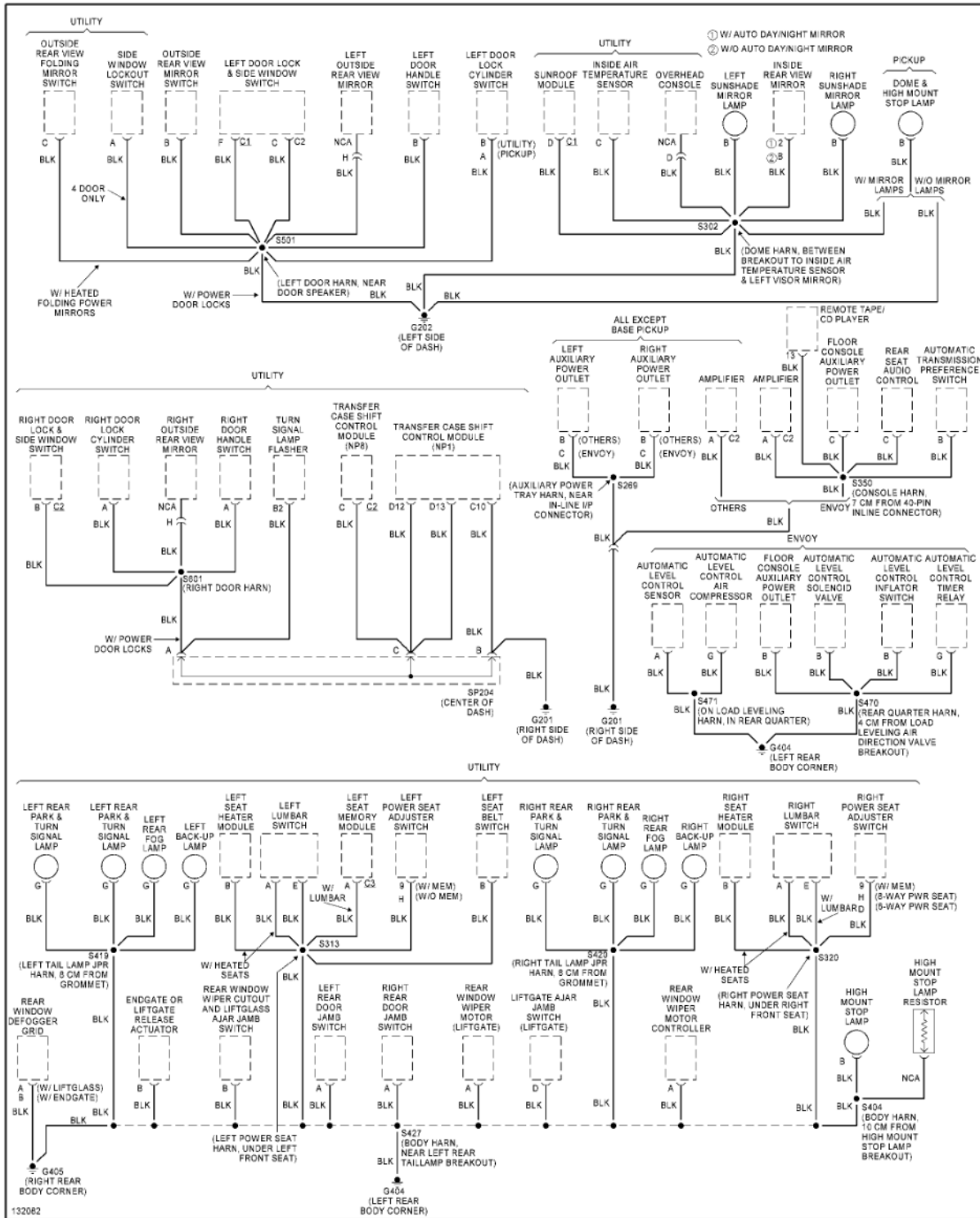

Fig. 31: Ground Distribution Circuit (3 of 3)

HEADLIGHTS

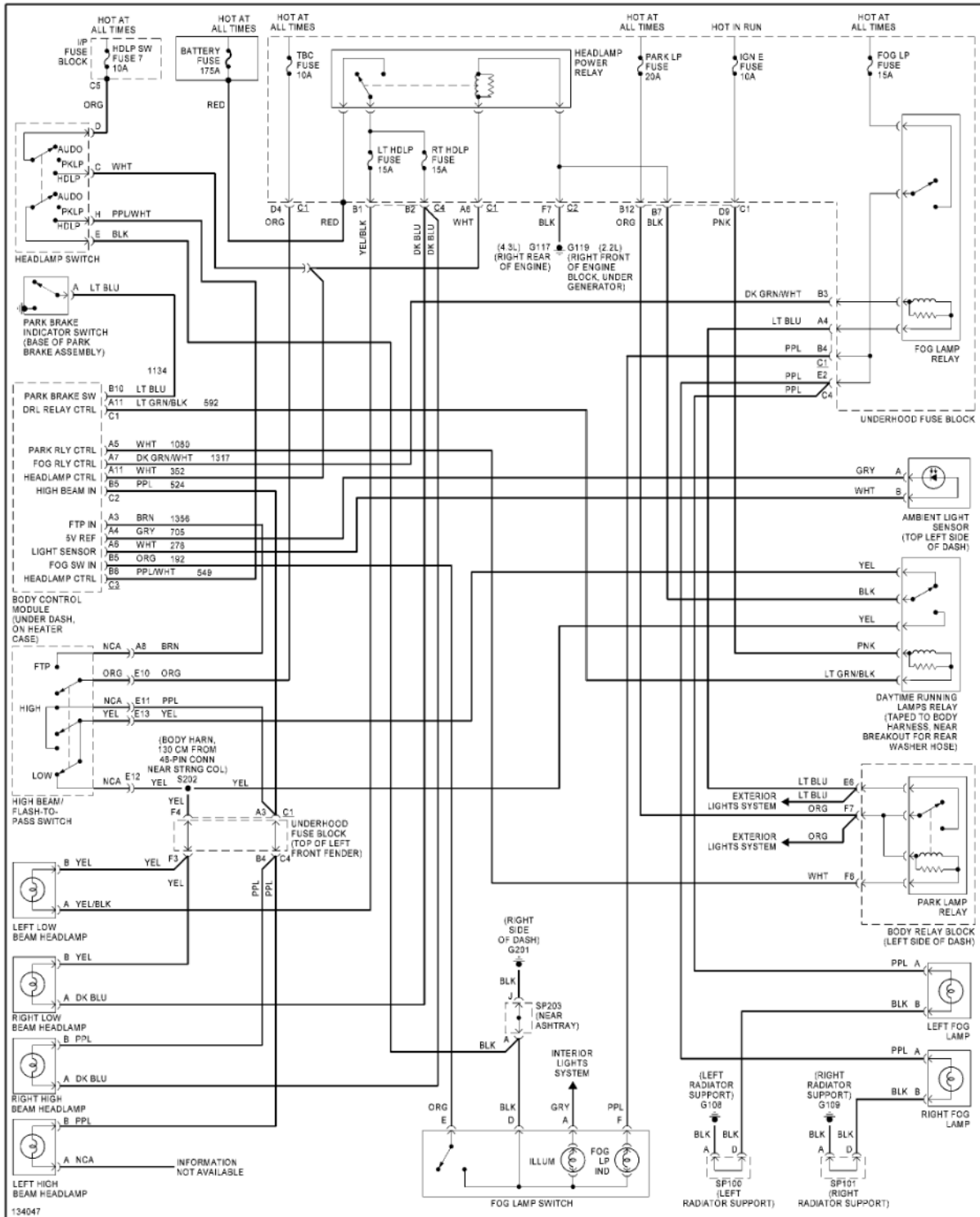

Fig. 32: Headlight Circuit, W/ ZR2

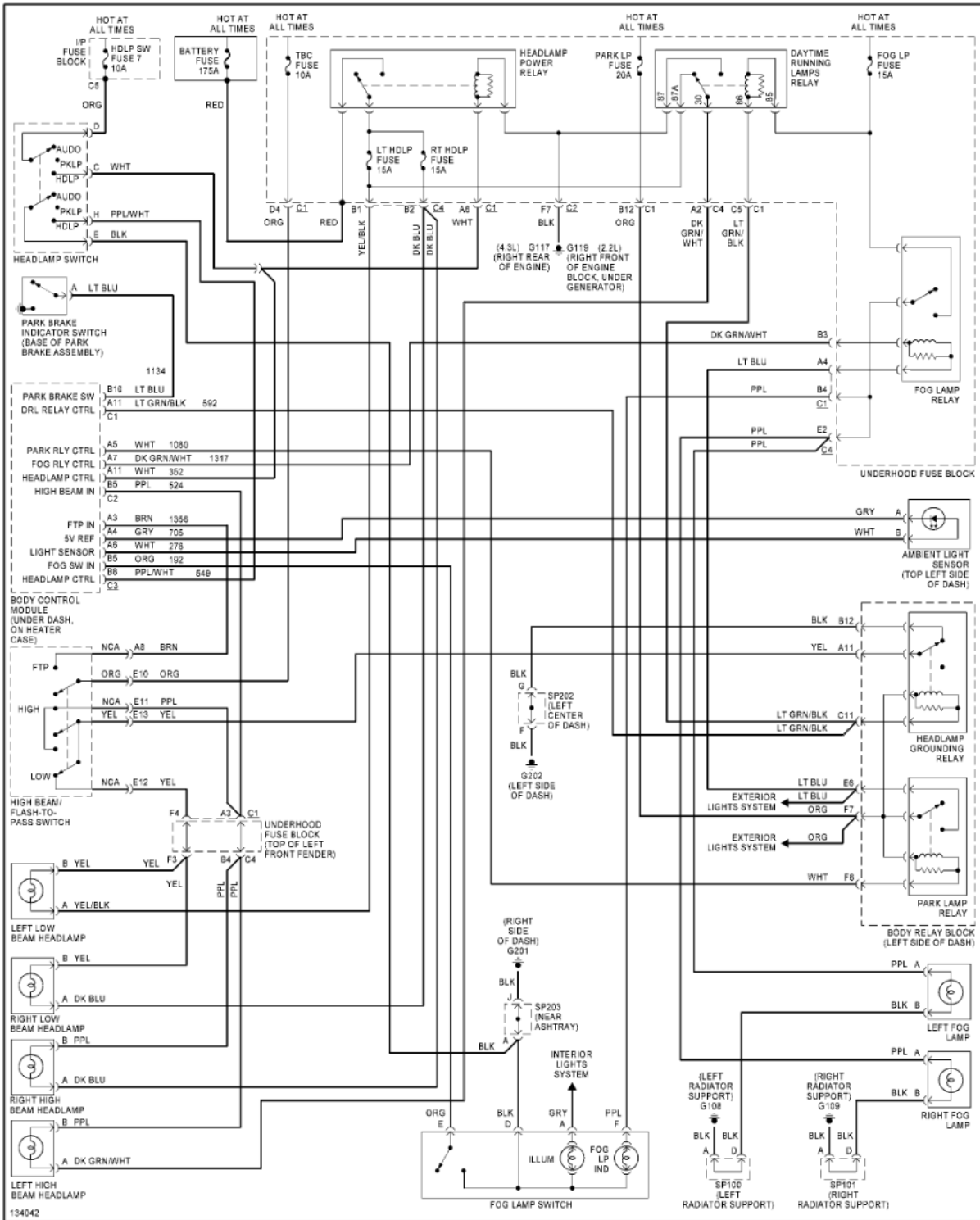

Fig. 33: Headlight Circuit, W/O ZR2



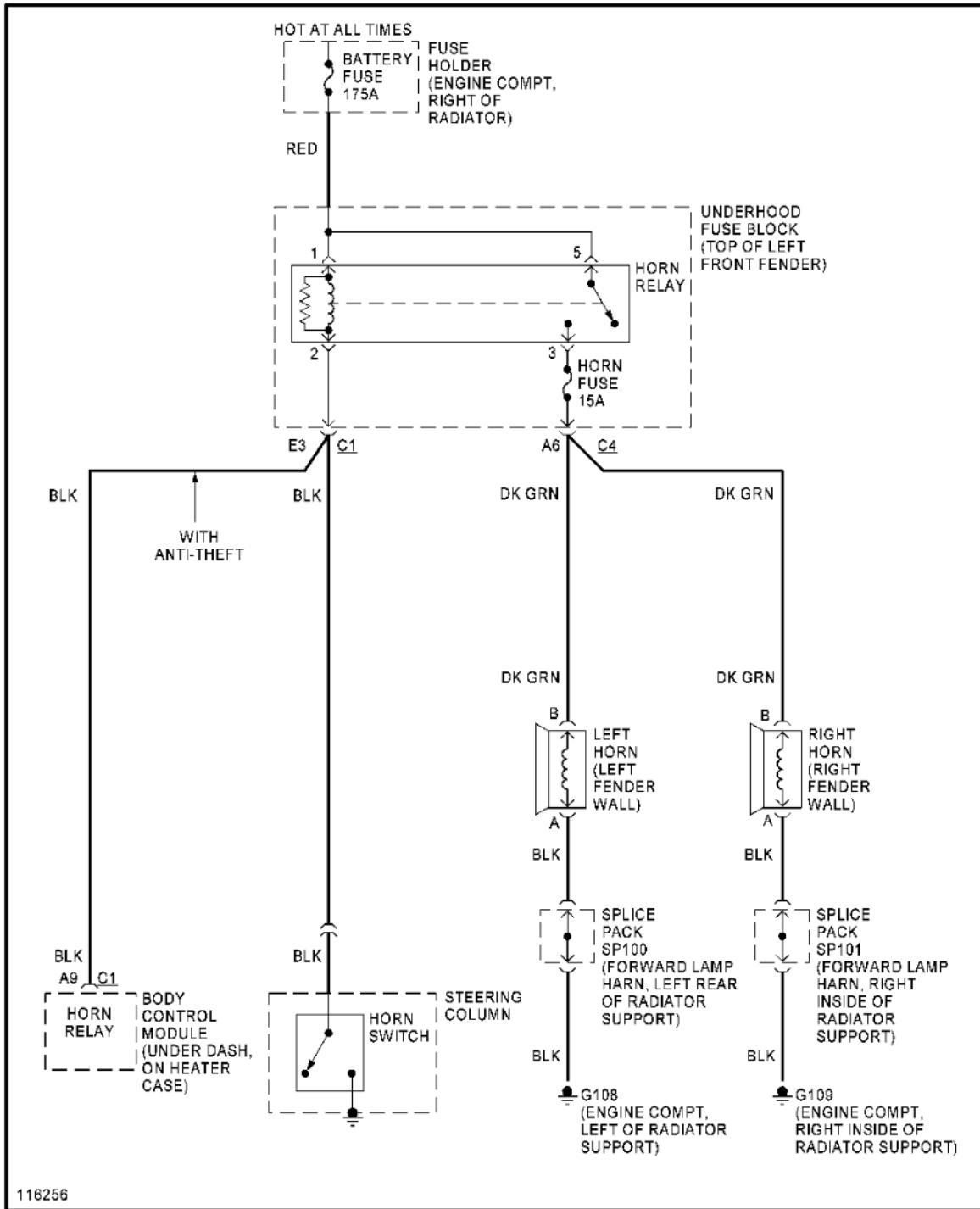

Fig. 34: Horn Circuit

INSTRUMENT CLUSTER

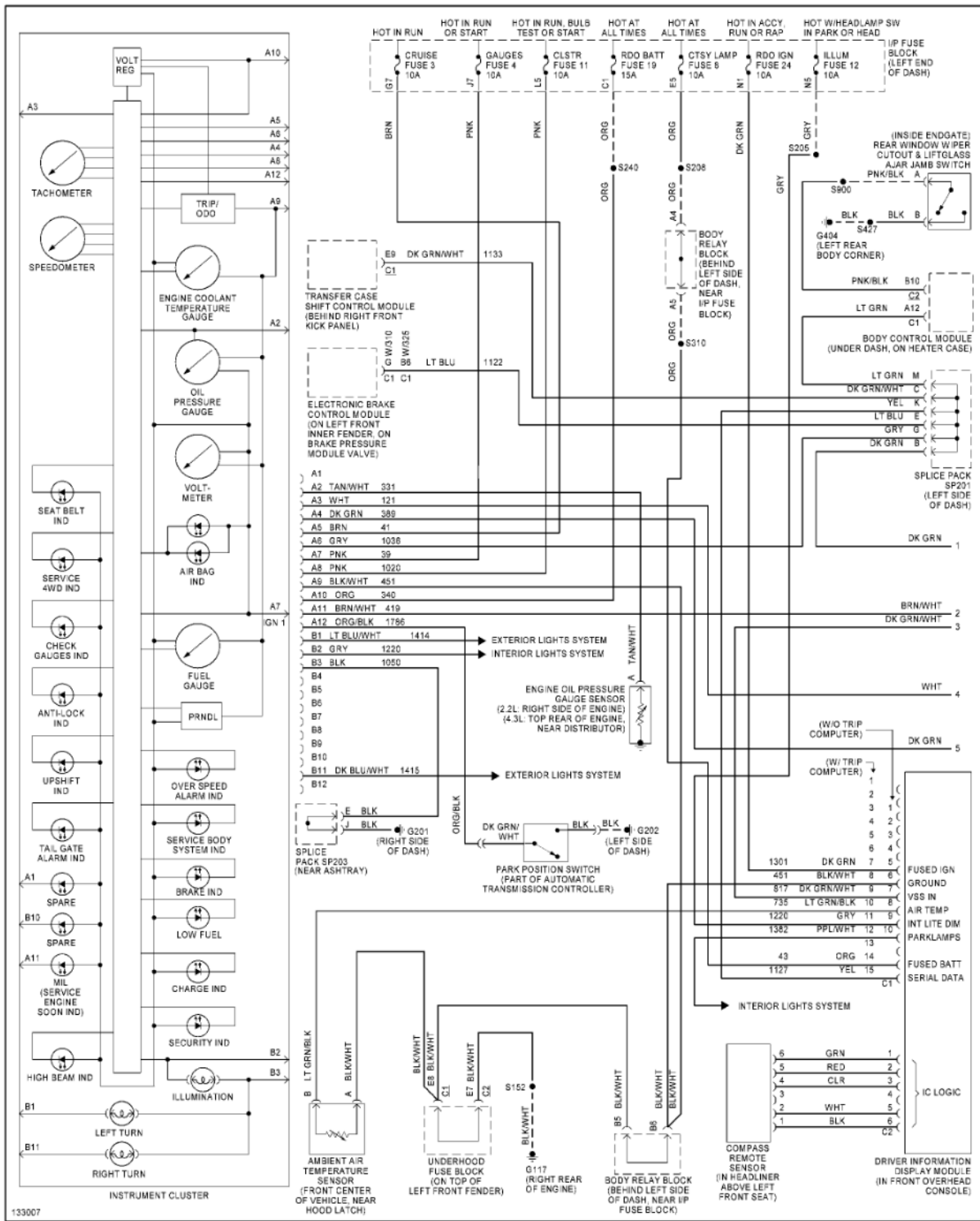

Fig. 35: Instrument Cluster Circuit (1 of 2)

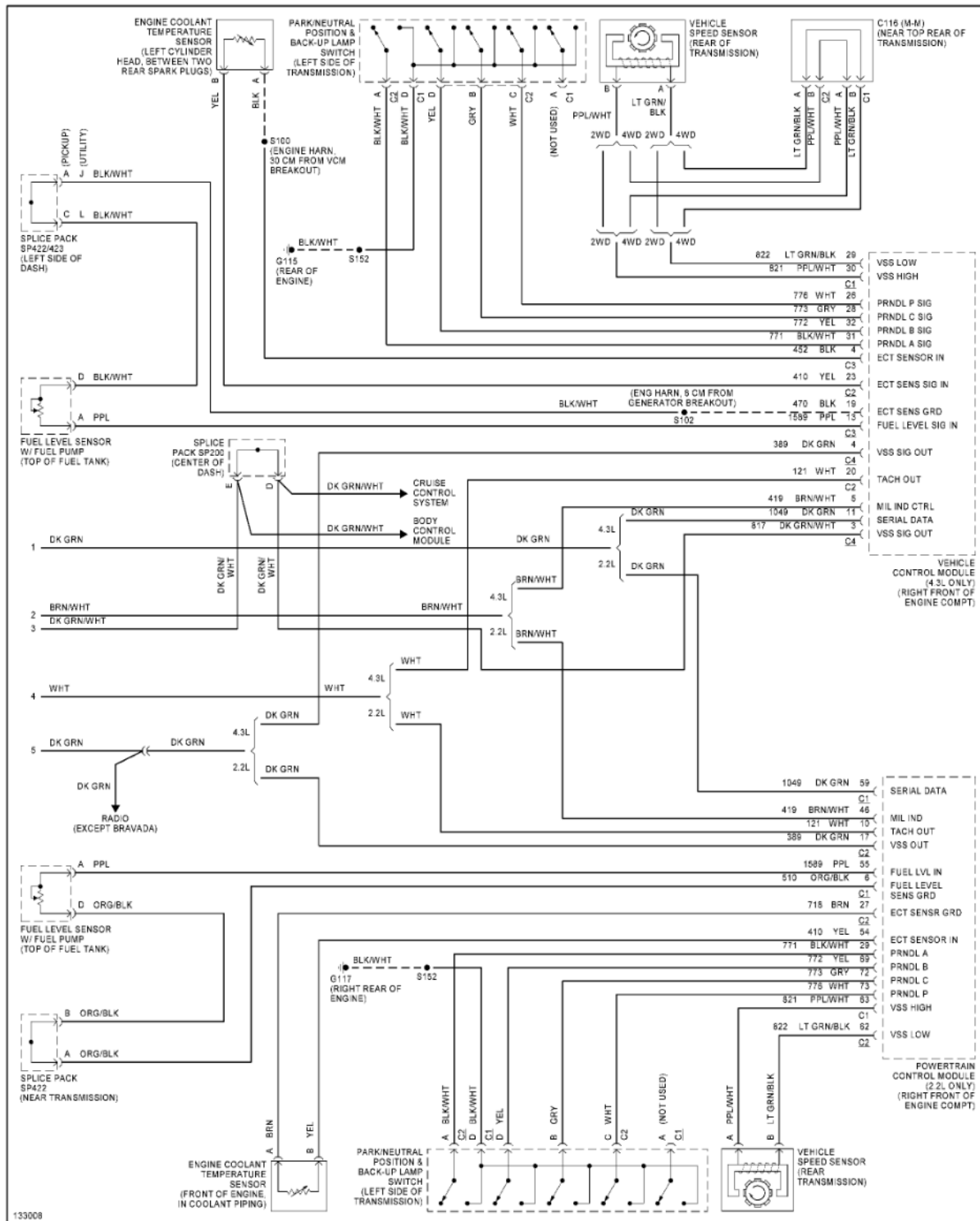

Fig. 36: Instrument Cluster Circuit (2 of 2)

INTERIOR LIGHTS

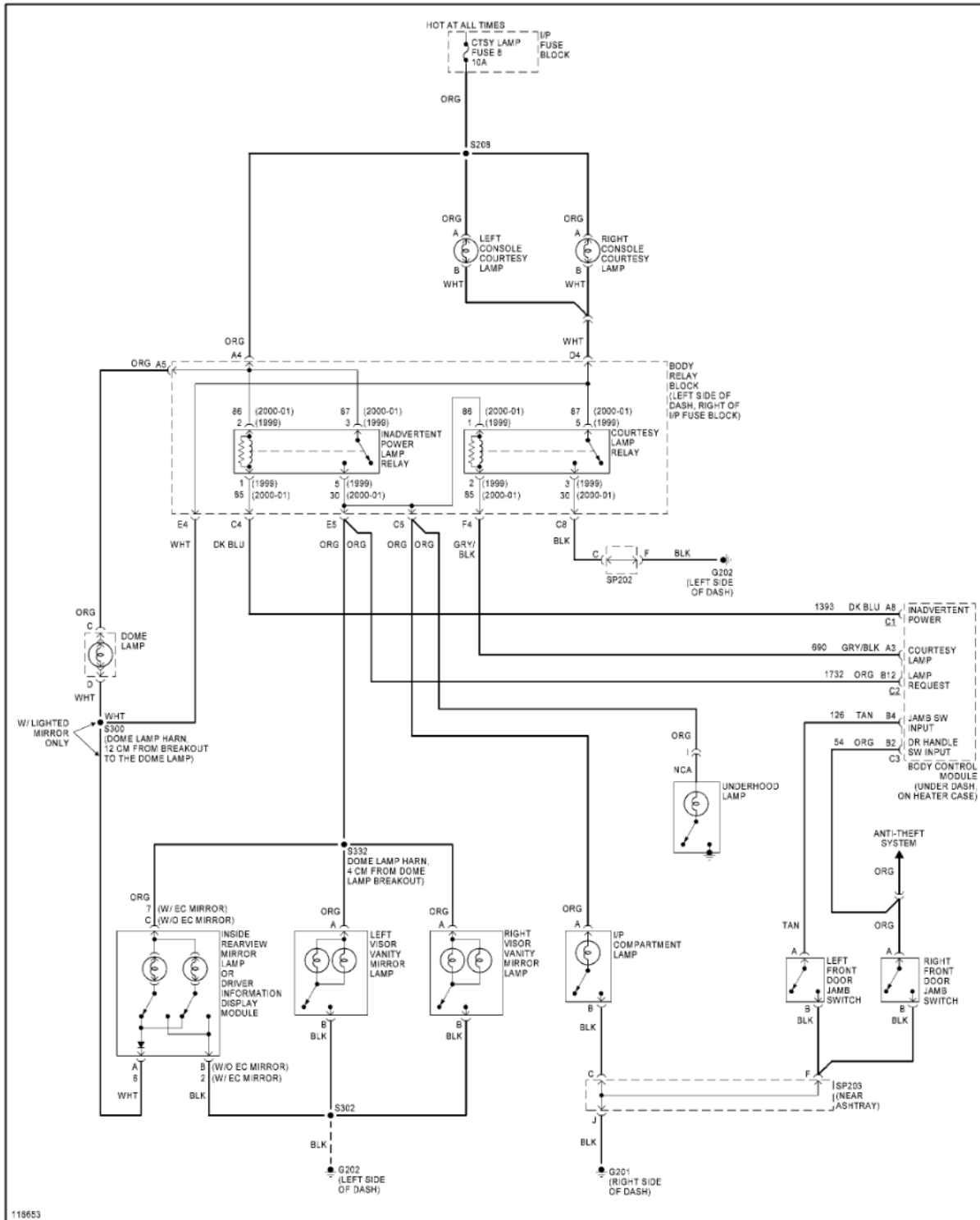

Fig. 37: Courtesy Lamps Circuit

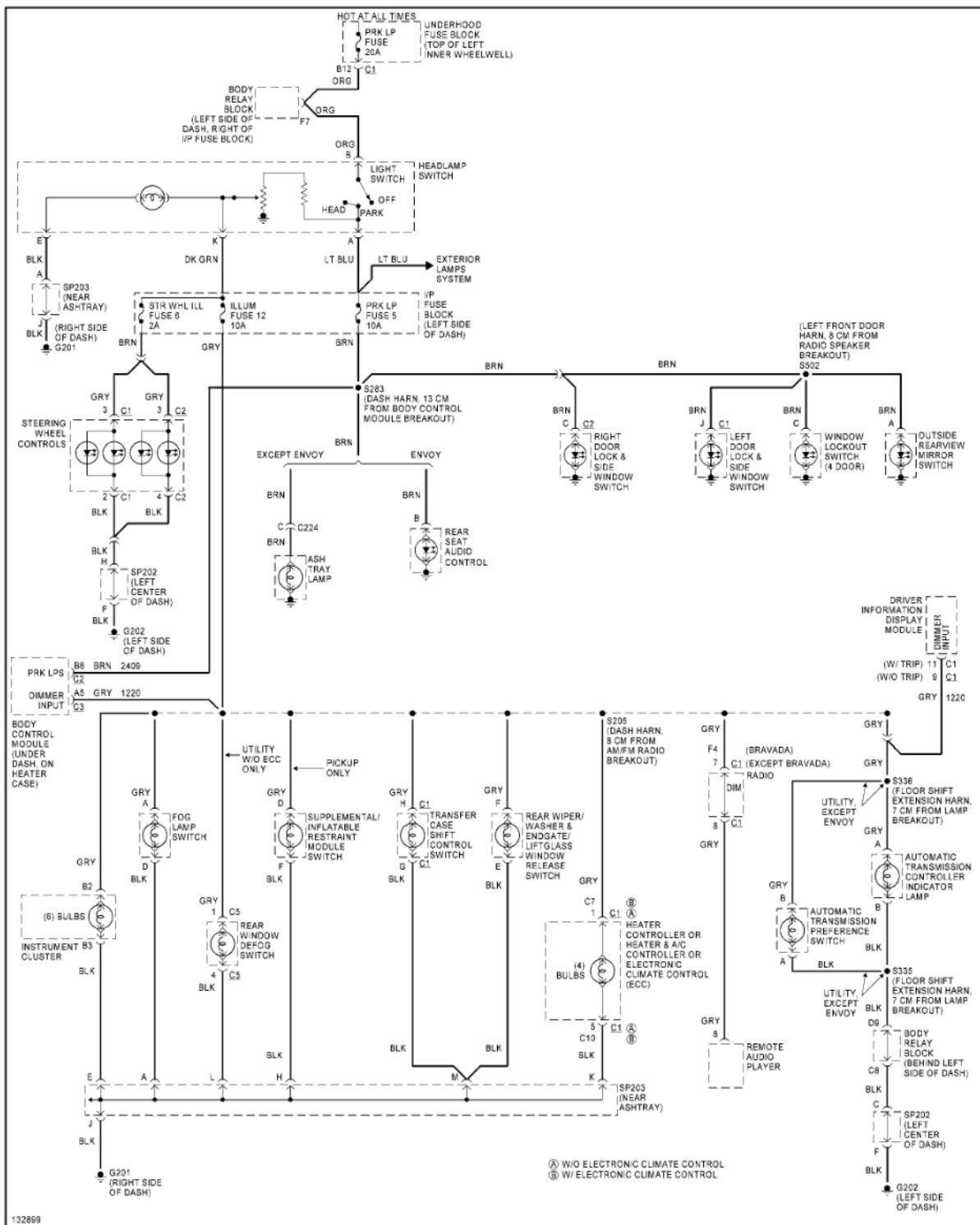

Fig. 38: Instrument Illumination Circuit

POWER DISTRIBUTION

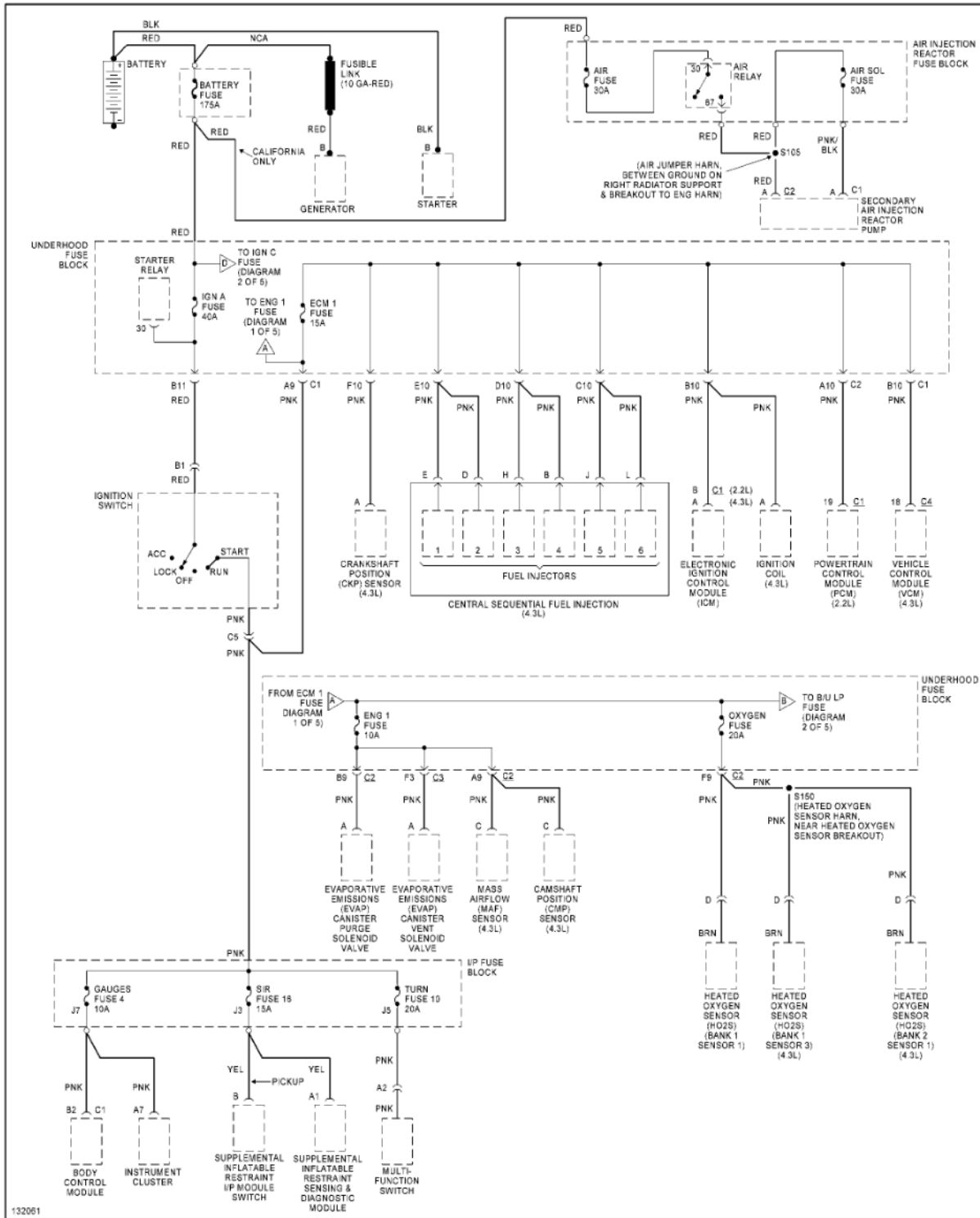

Fig. 39: Power Distribution Circuit (1 of 5)

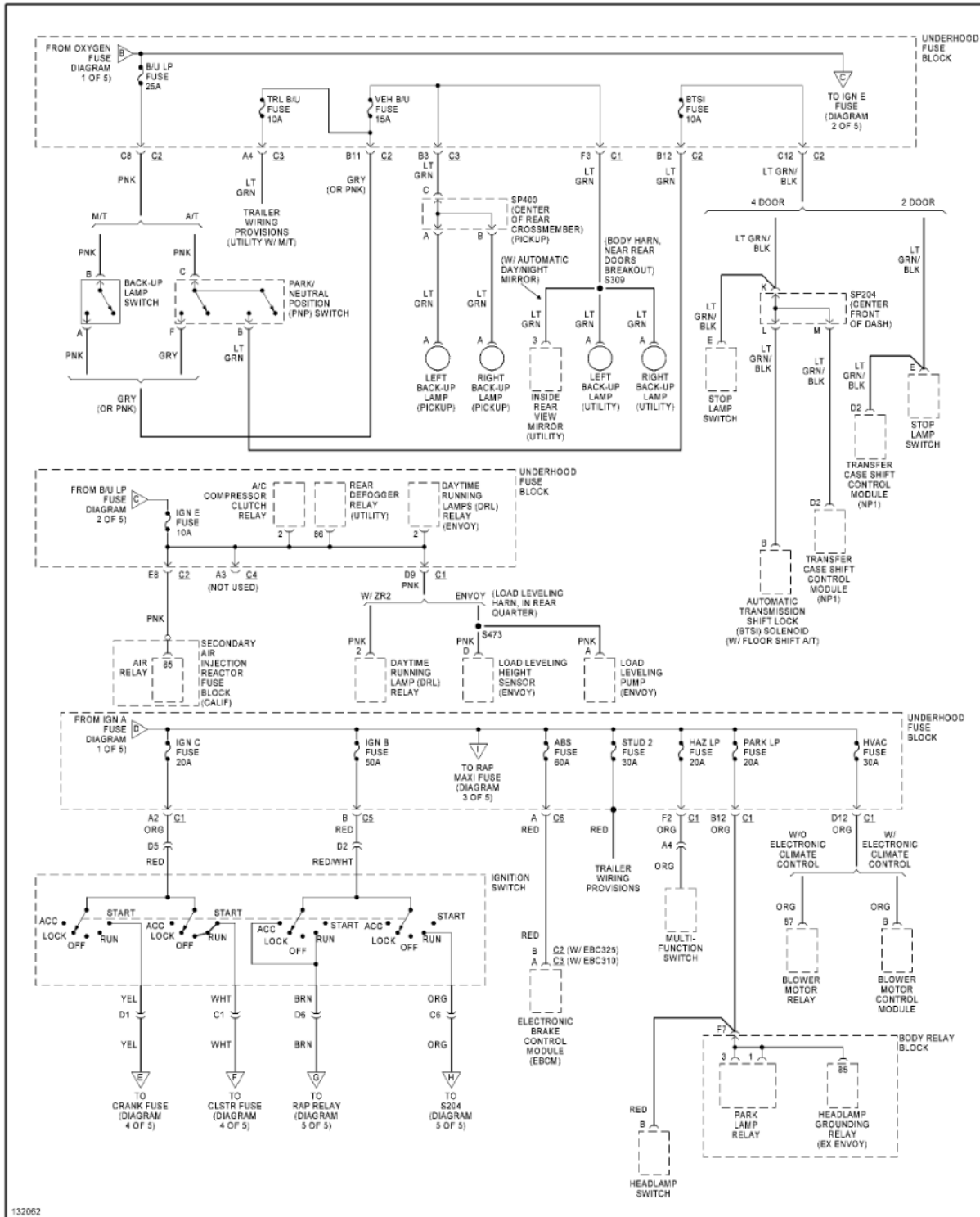

Fig. 40: Power Distribution Circuit (2 of 5)

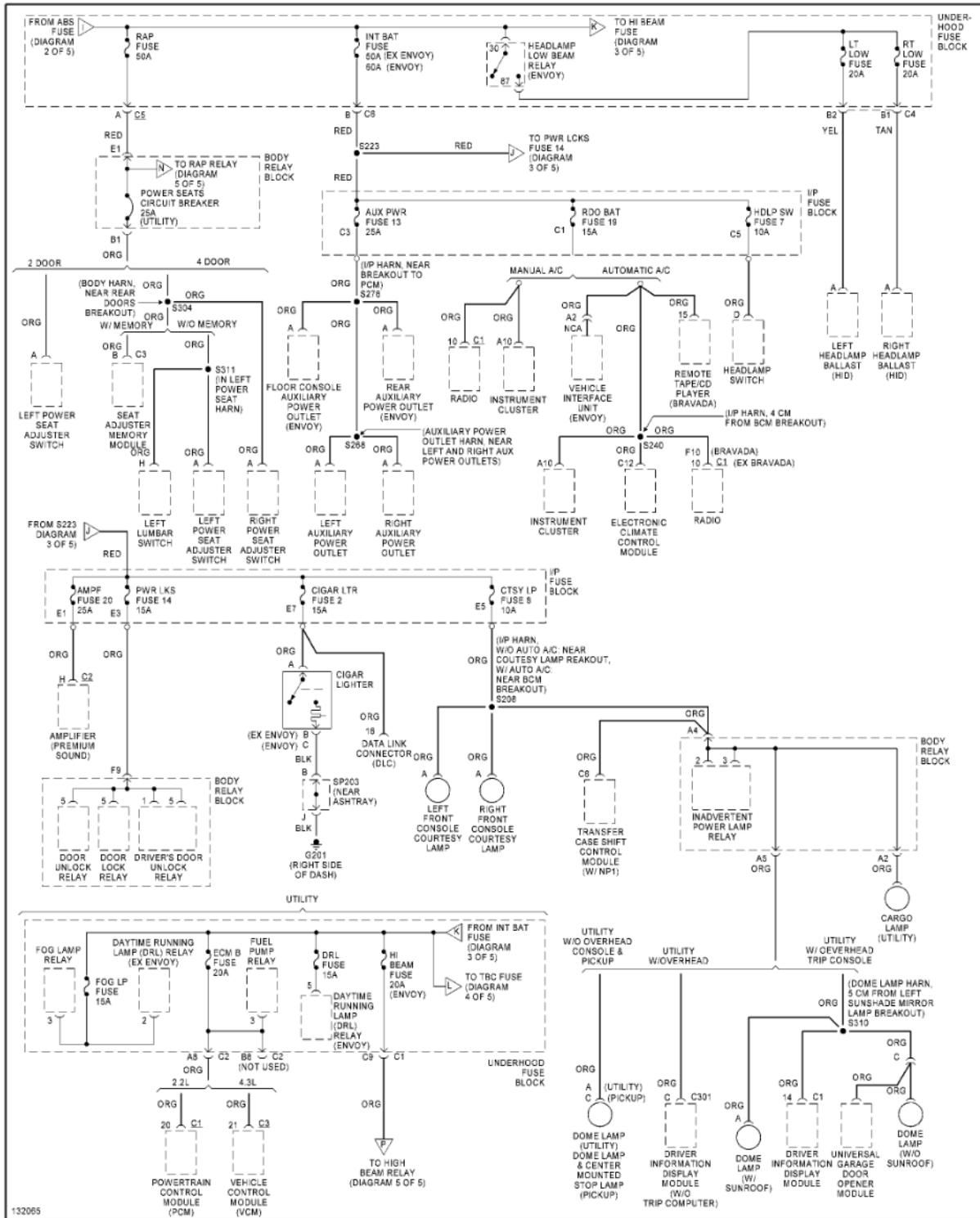

Fig. 41: Power Distribution Circuit (3 of 5)

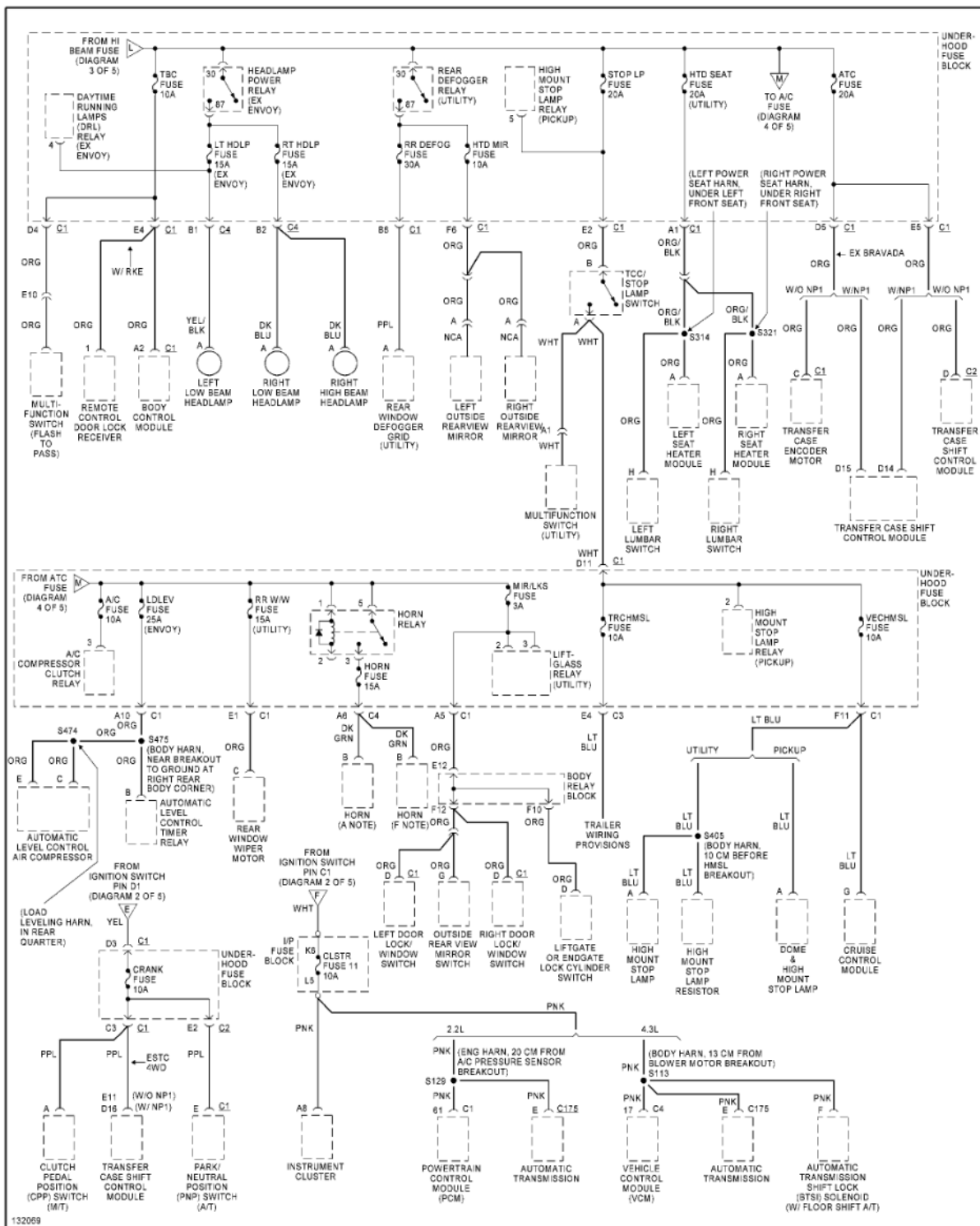

Fig. 42: Power Distribution Circuit (4 of 5)

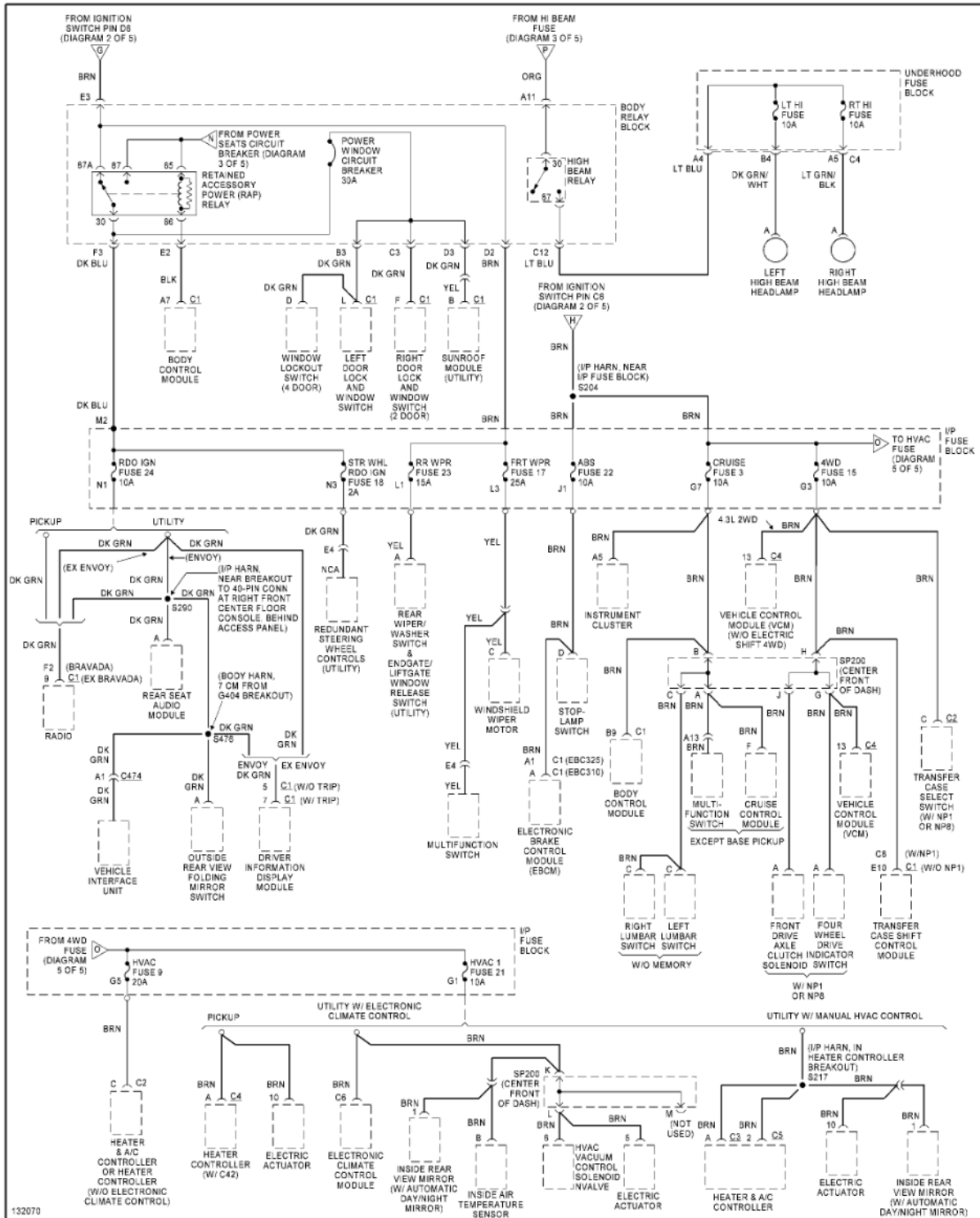

Fig. 43: Power Distribution Circuit (5 of 5)

POWER DOOR LOCKS

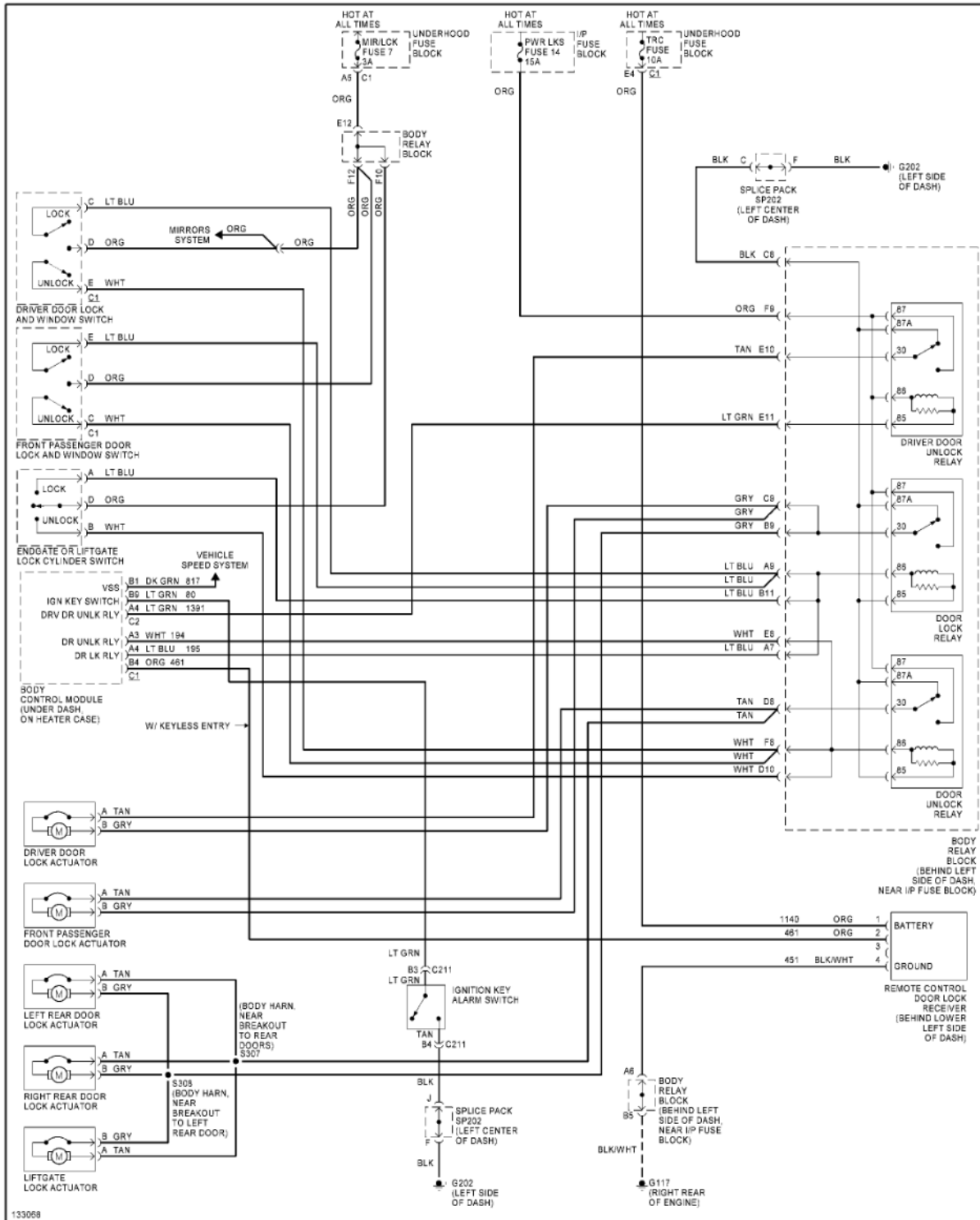

Fig. 44: Power Door Lock Circuit

POWER MIRRORS 

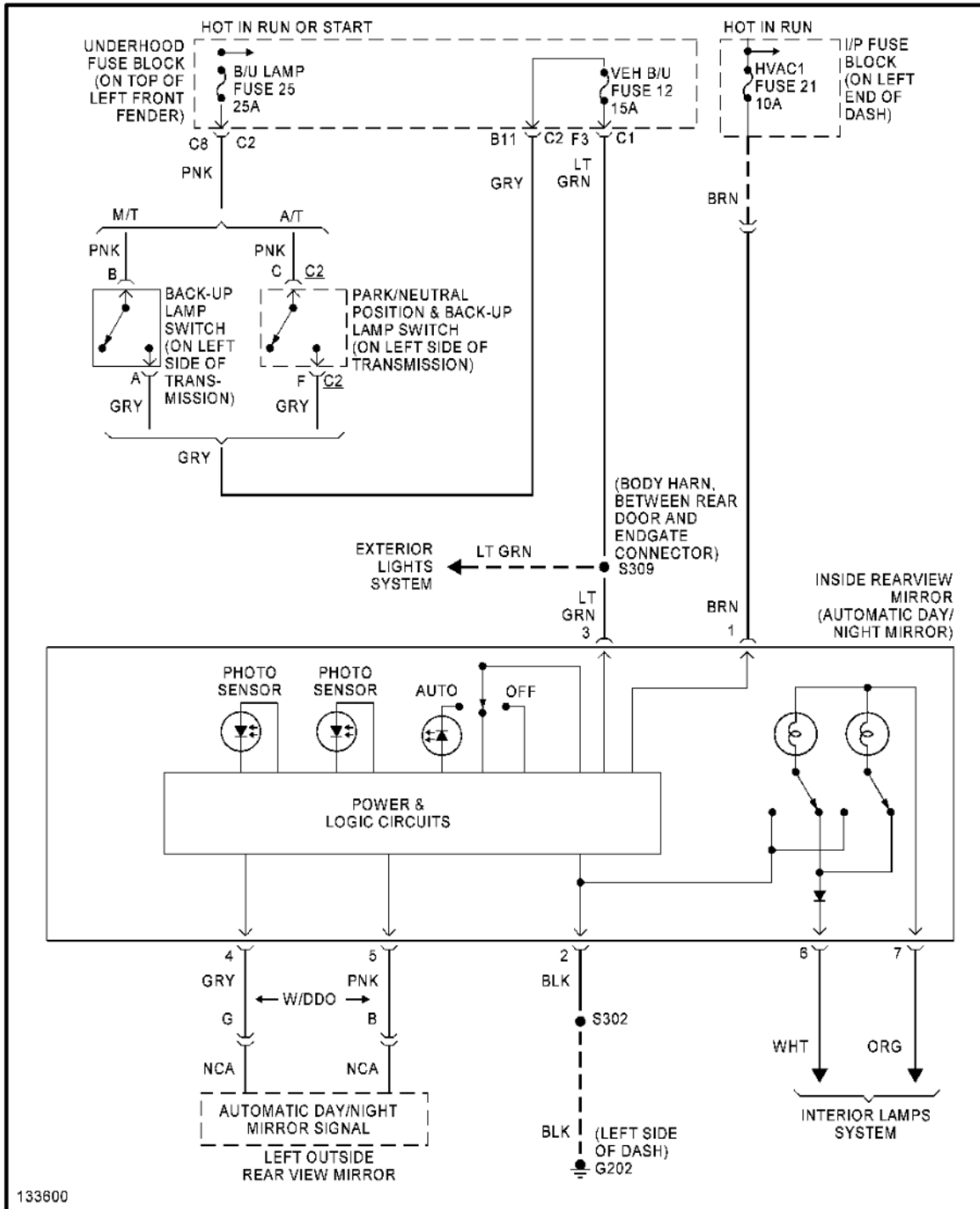

Fig. 45: Electrochromic Mirror Circuit

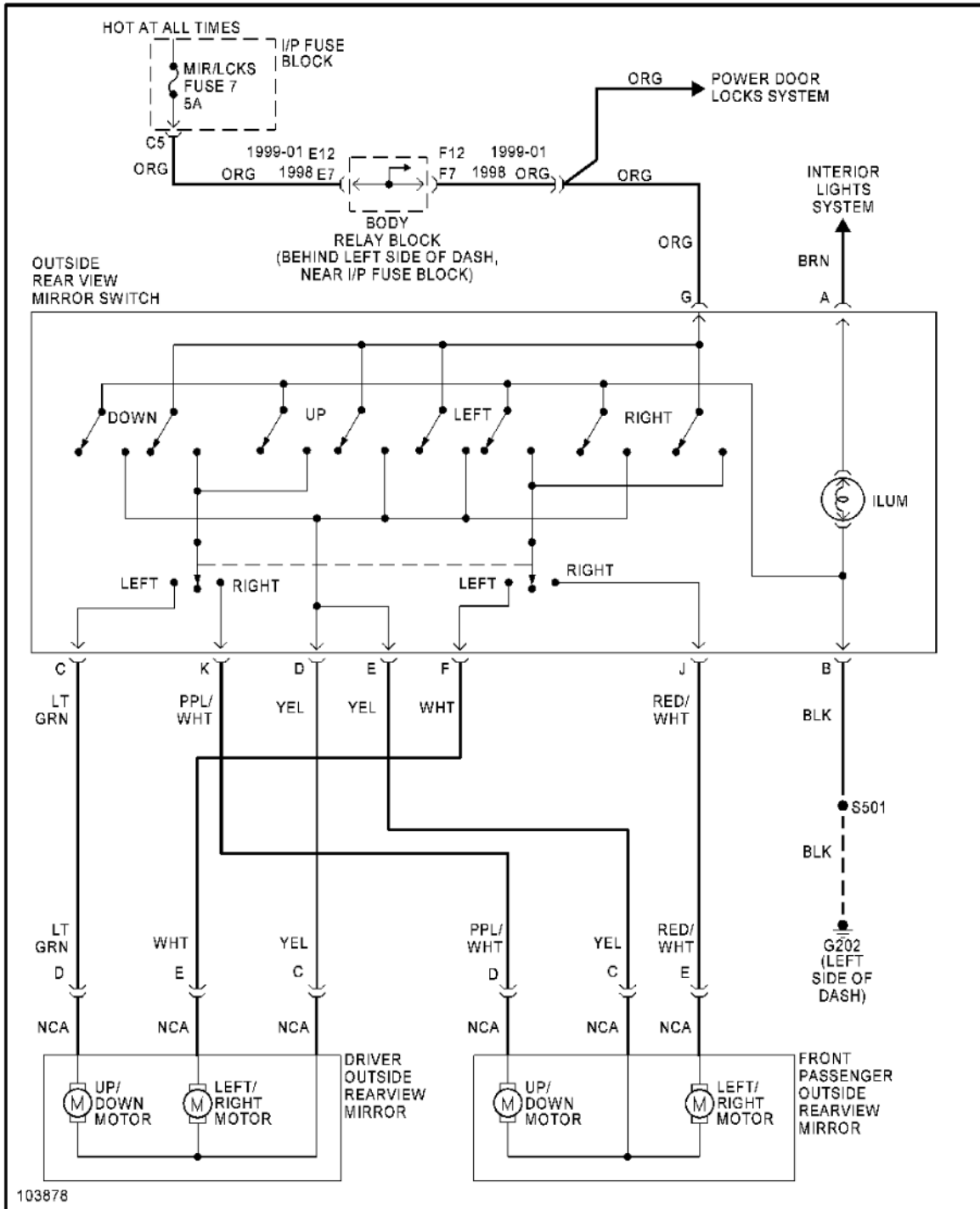

Fig. 46: Power Mirrors Circuit

POWER SEATS 

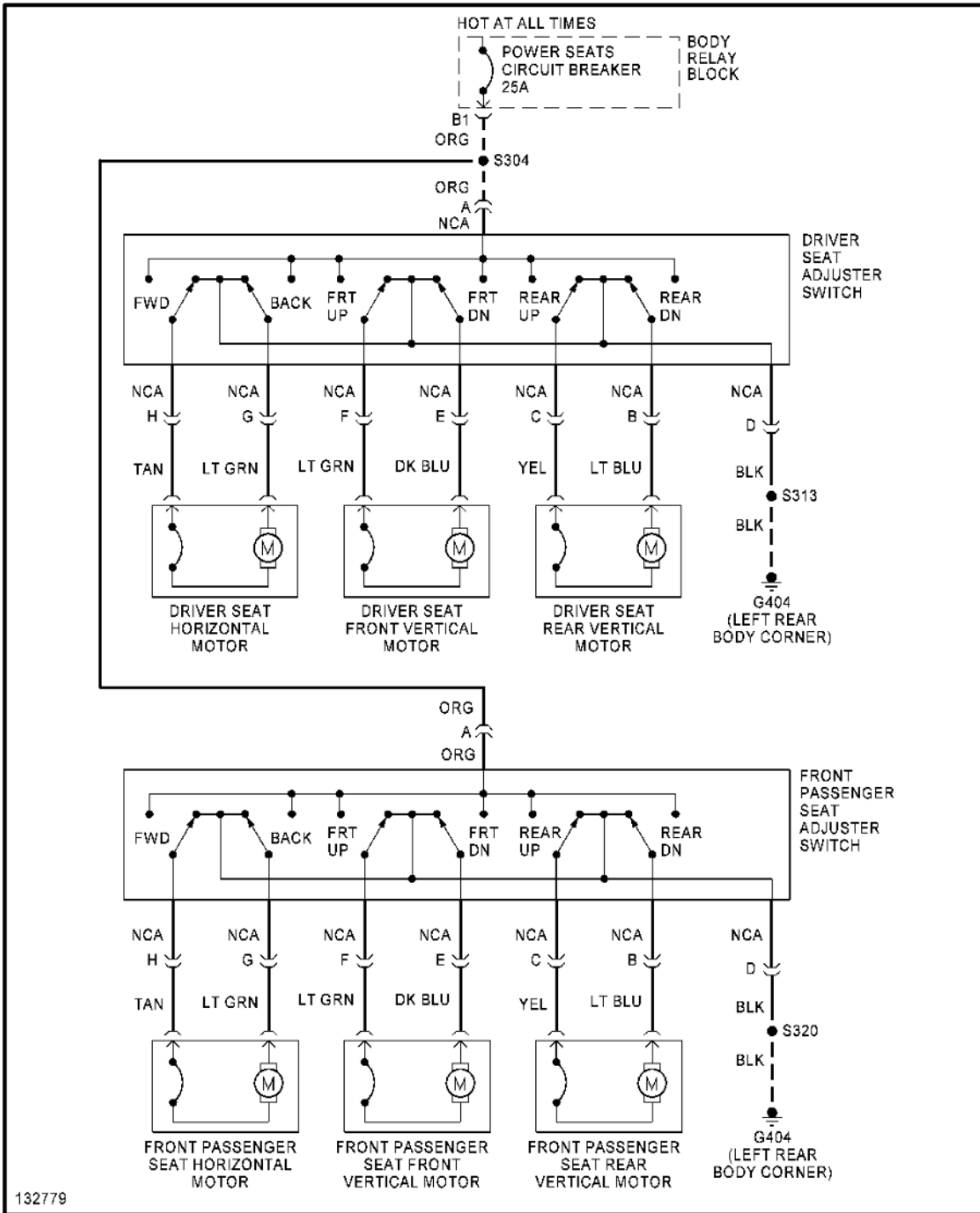

Fig. 47: 6-Way Power Seat Circuit

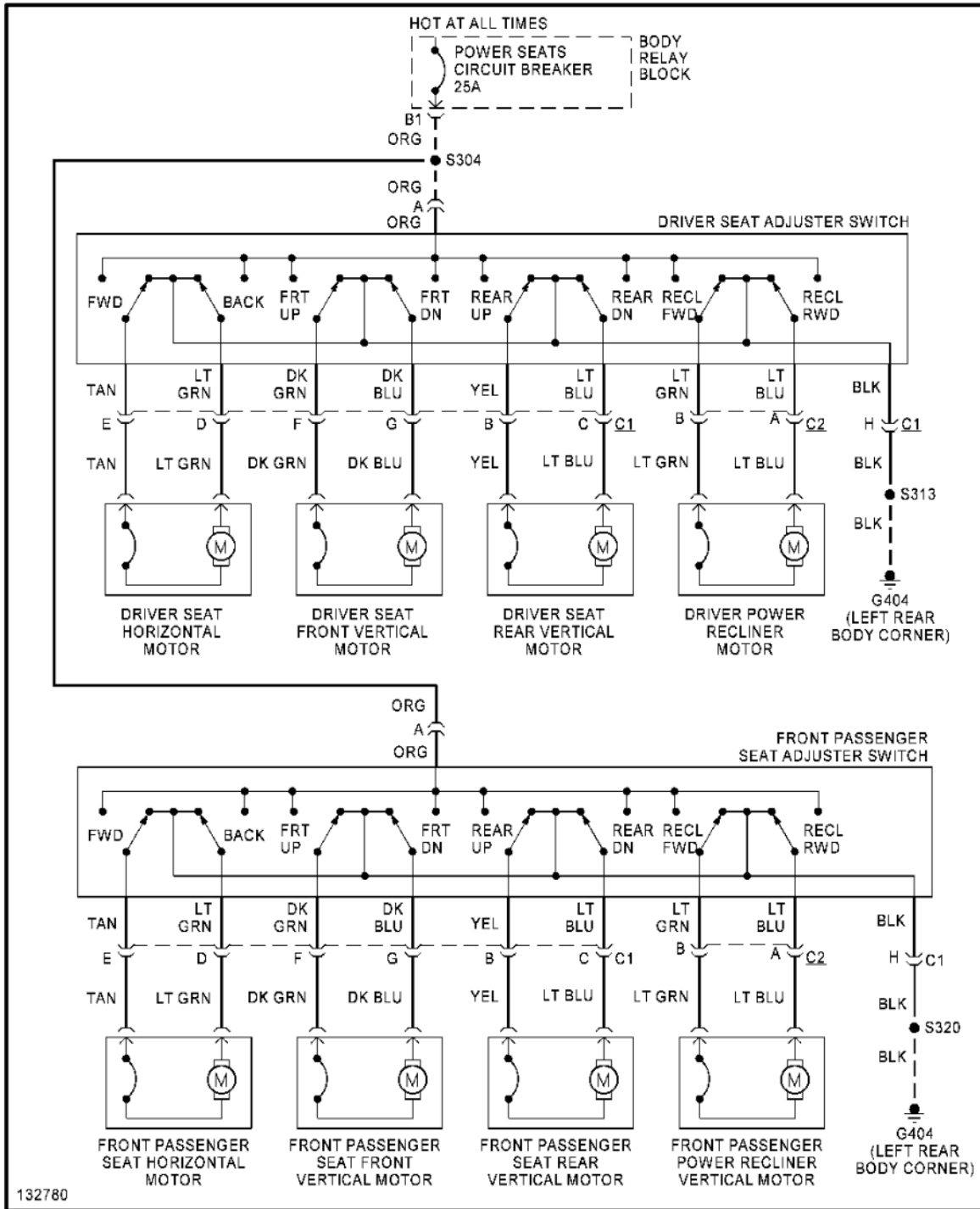

Fig. 48: 8-Way Adjustable Power Seat Circuit

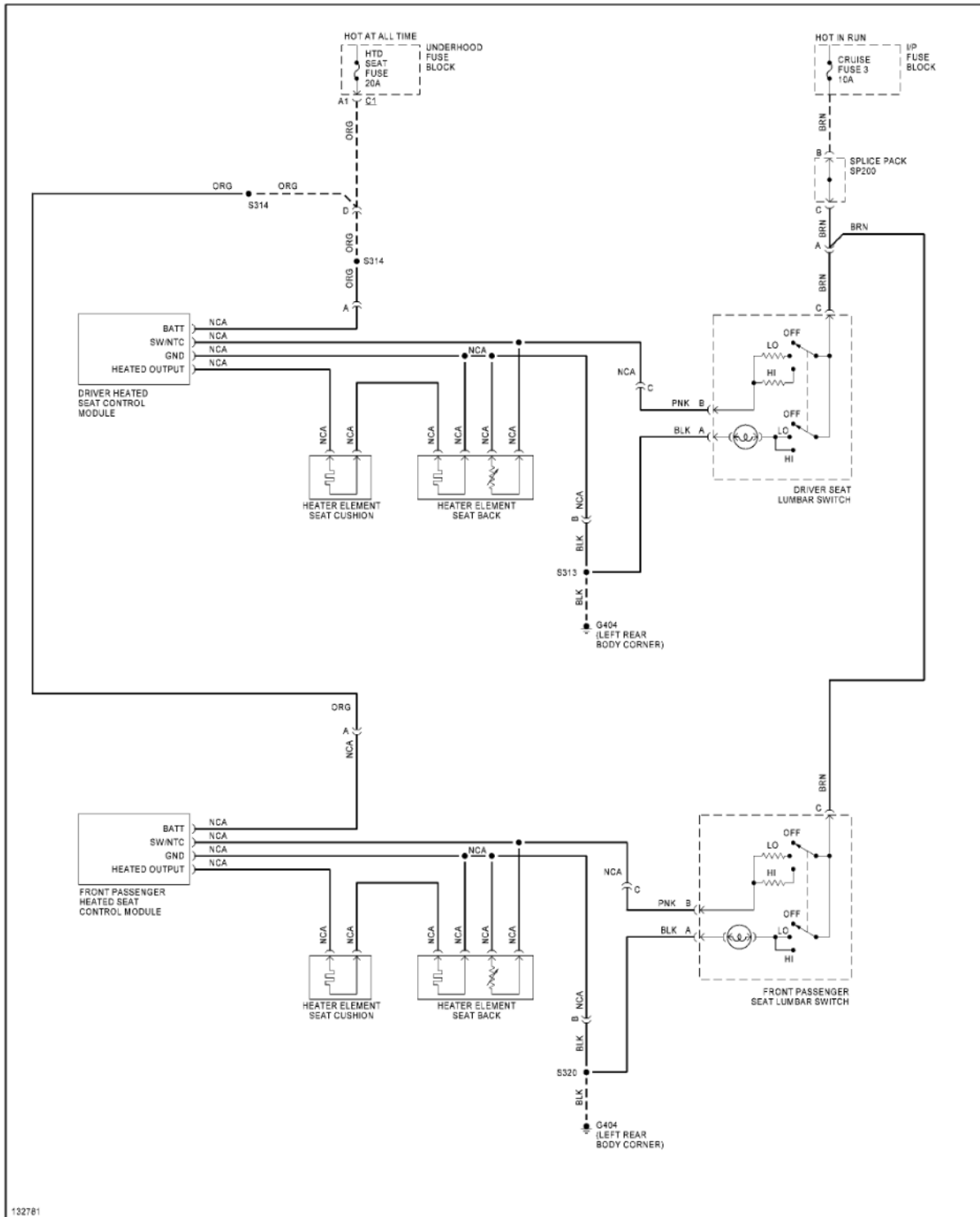

Fig. 49: Heated Seats Circuit

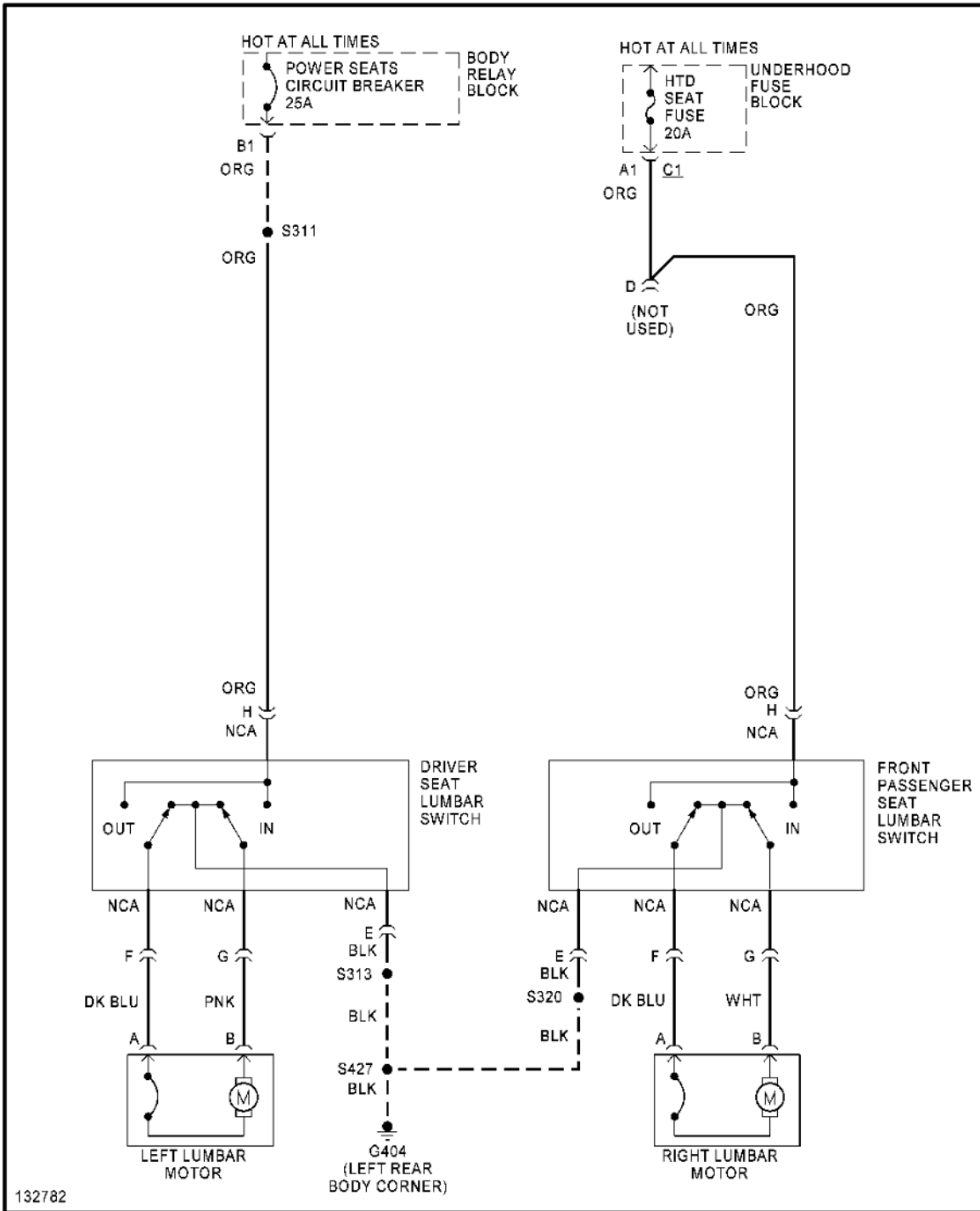

Fig. 50: Lumbar Circuit

POWER WINDOWS

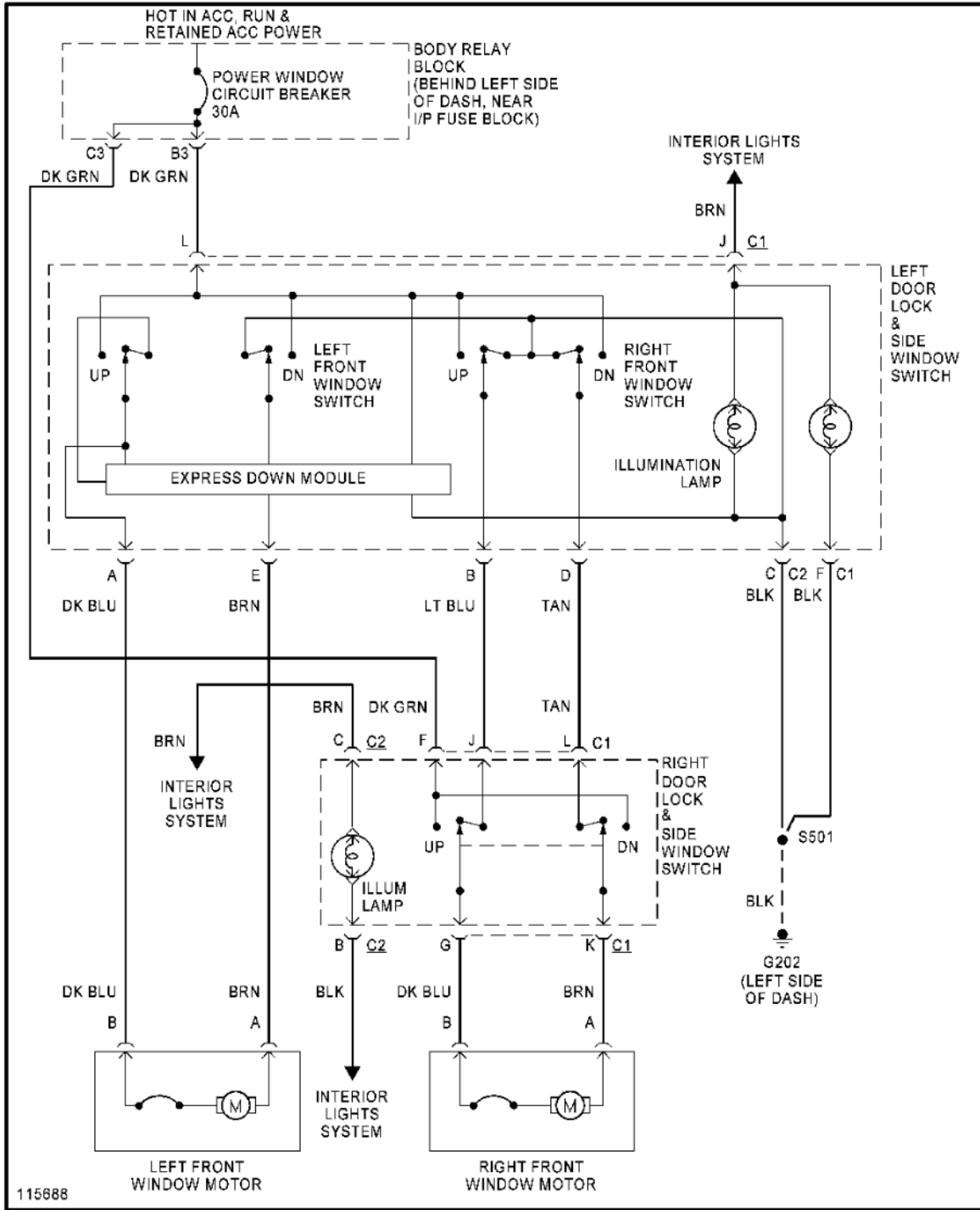

Fig. 51: Power Window Circuit

RADIO 

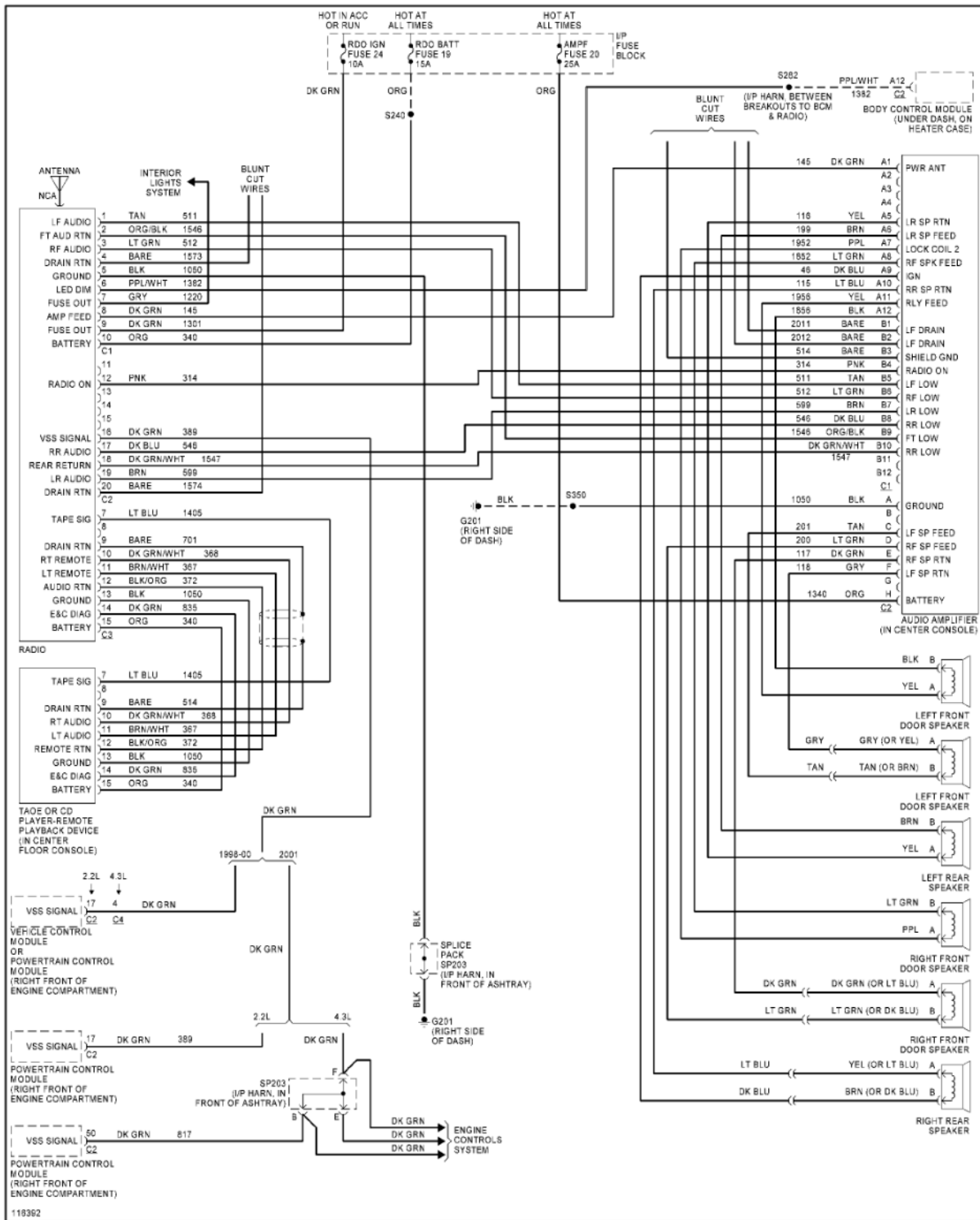

Fig. 52: Radio Circuits, W/ Amplifier

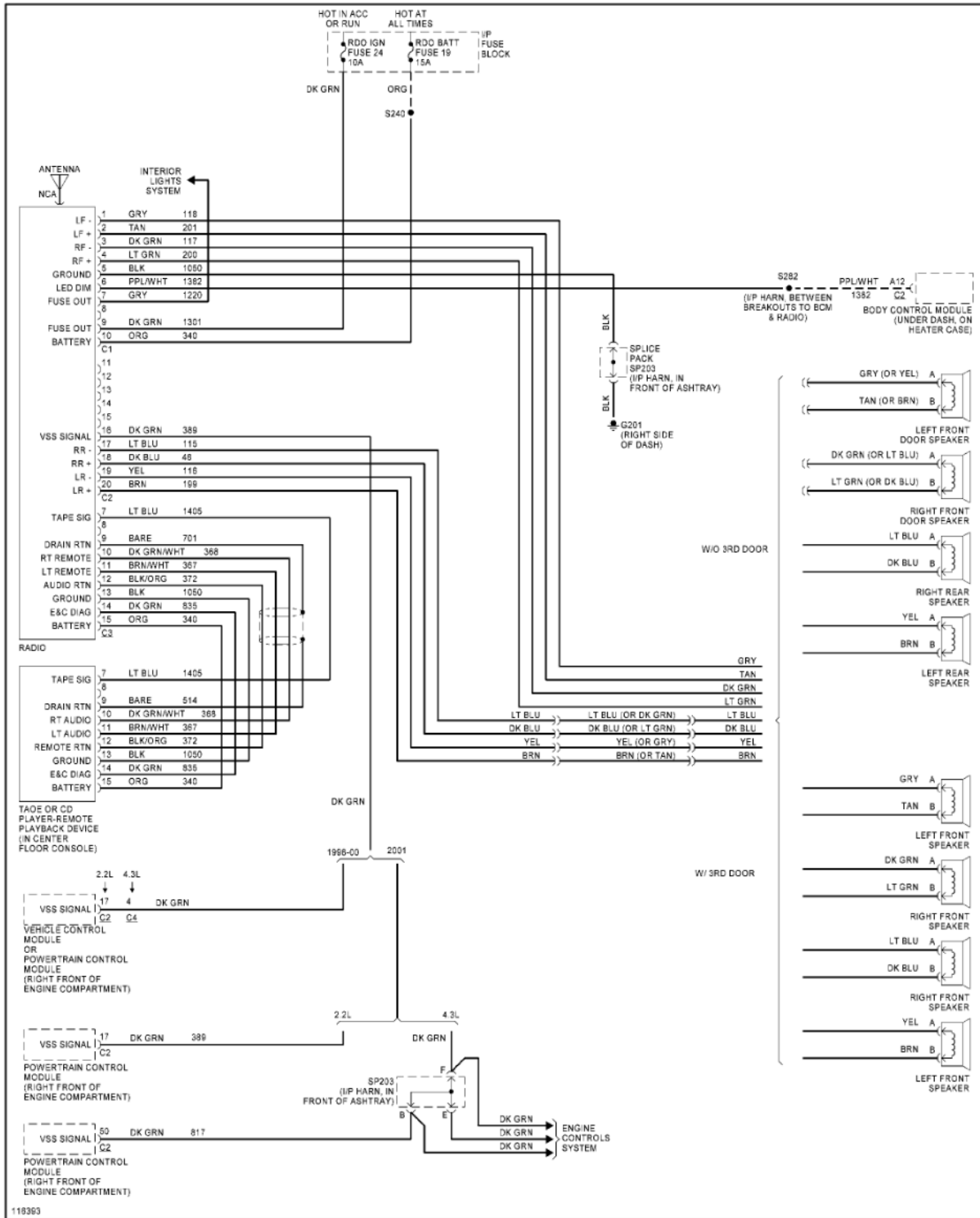

Fig. 53: Radio Circuits, W/O Amplifier

SHIFT INTERLOCKS

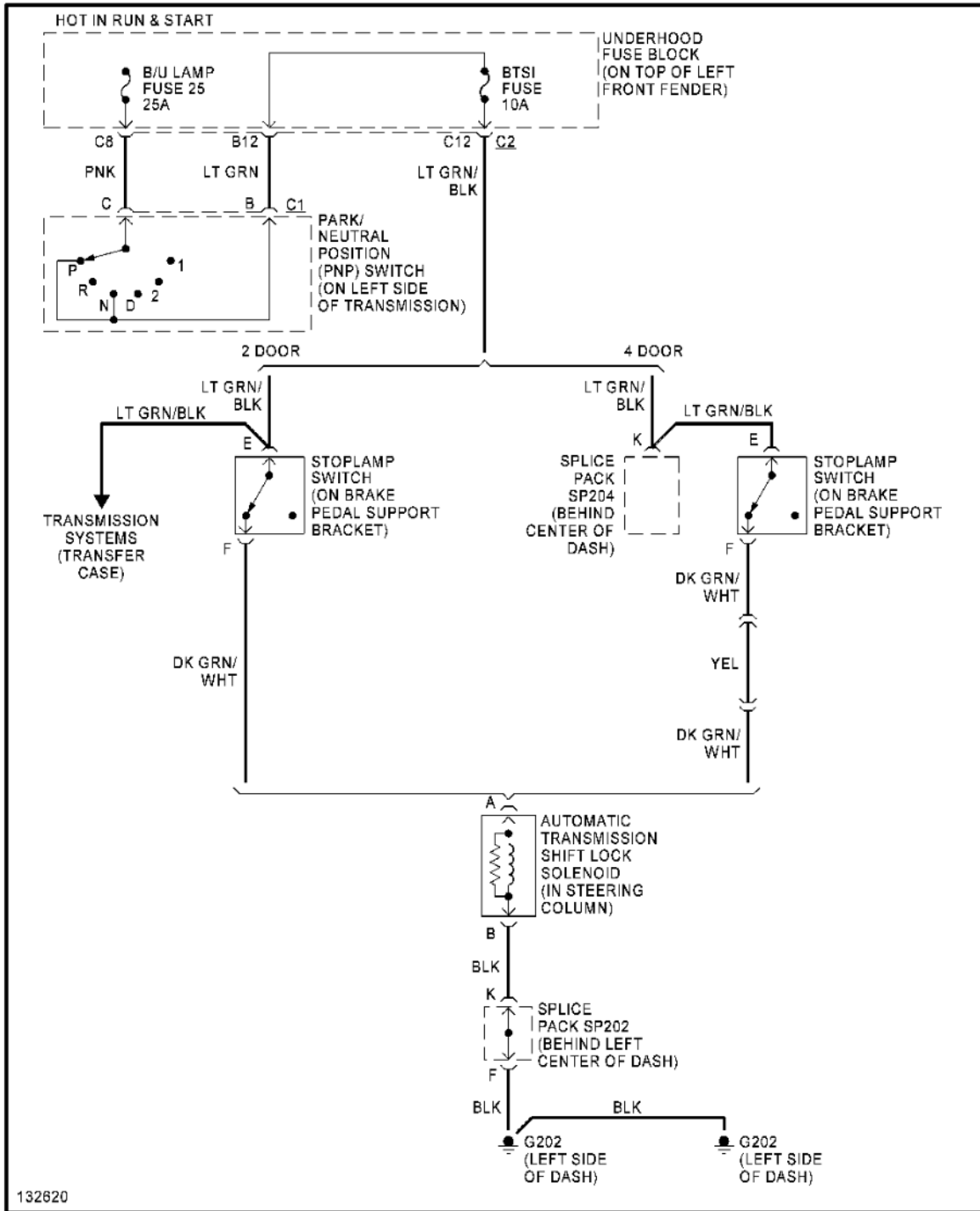

Fig. 54: Shift Interlock Circuit, W/ Column Shift

STARTING/CHARGING

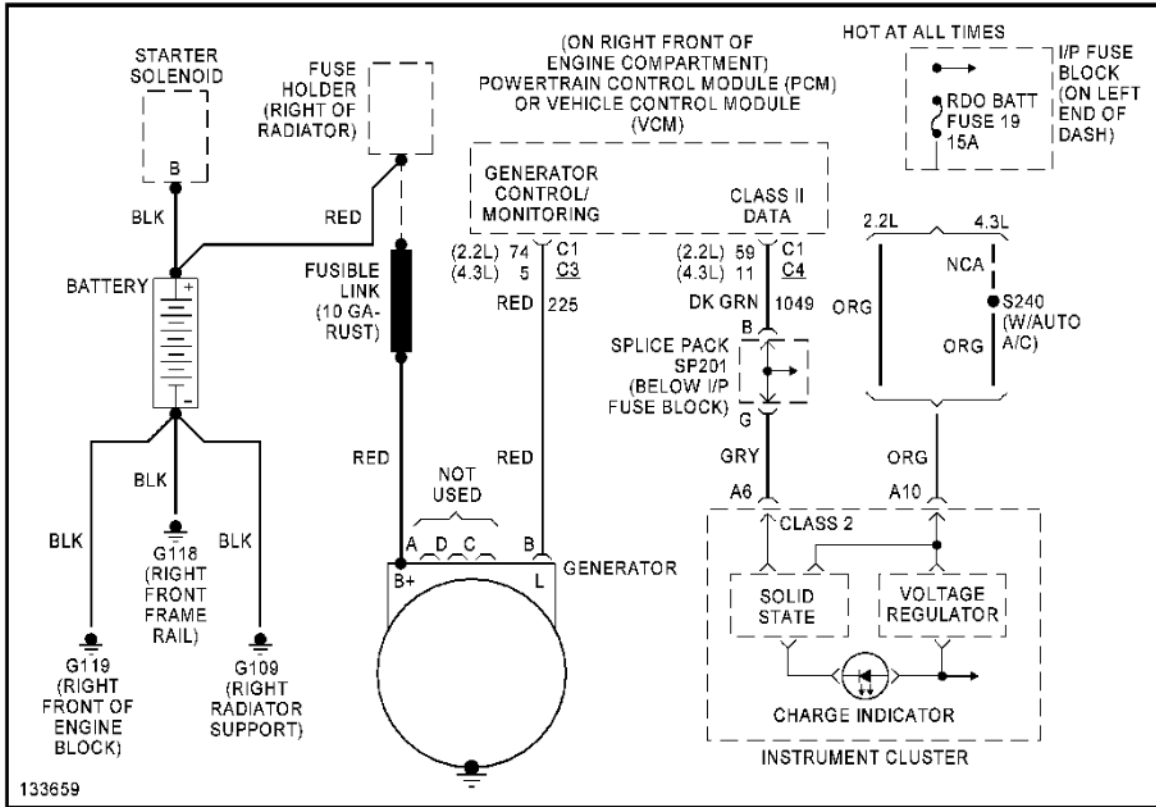

Fig. 55: Charging Circuit

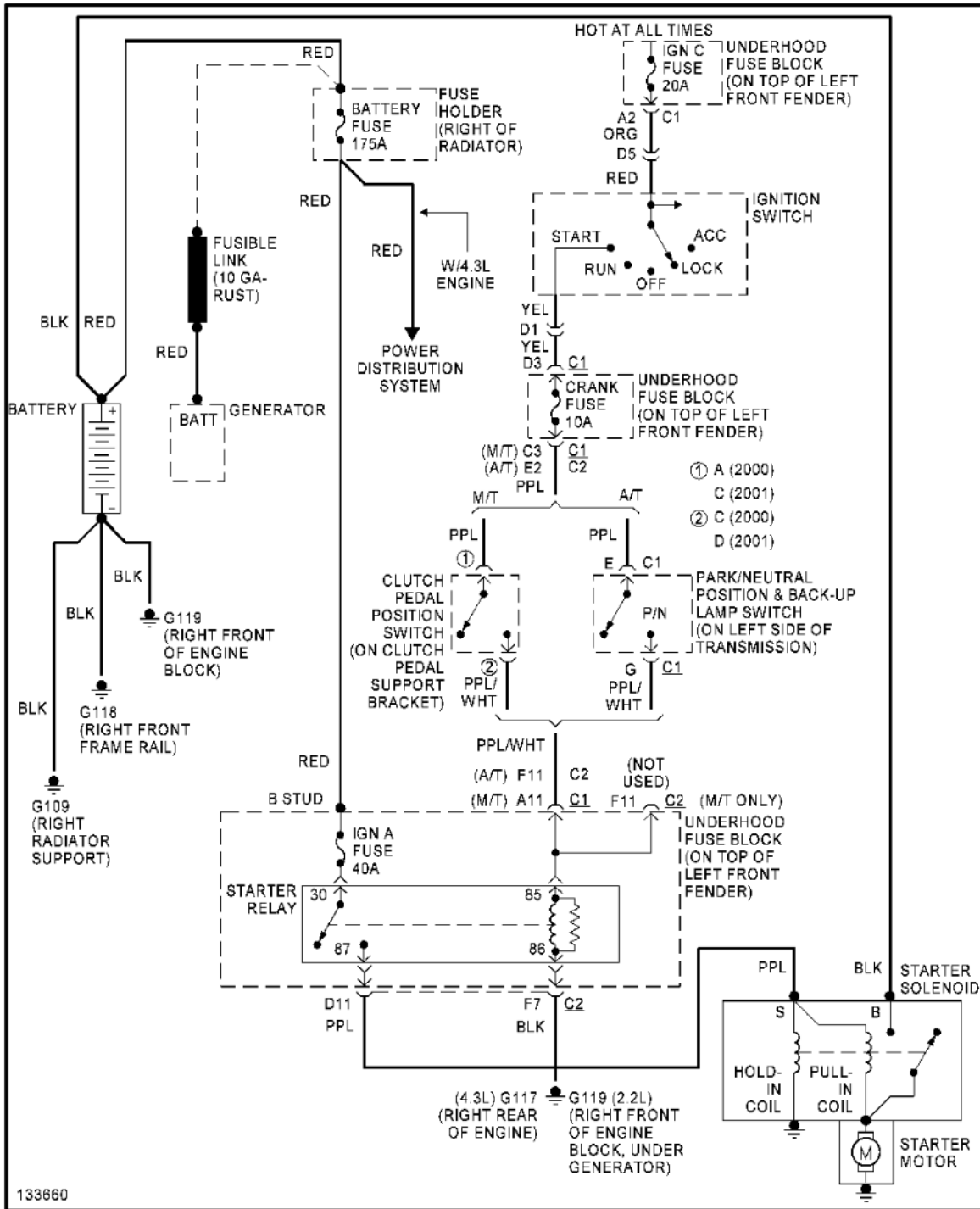

Fig. 56: Starting Circuit

SUPPLEMENTAL RESTRAINTS

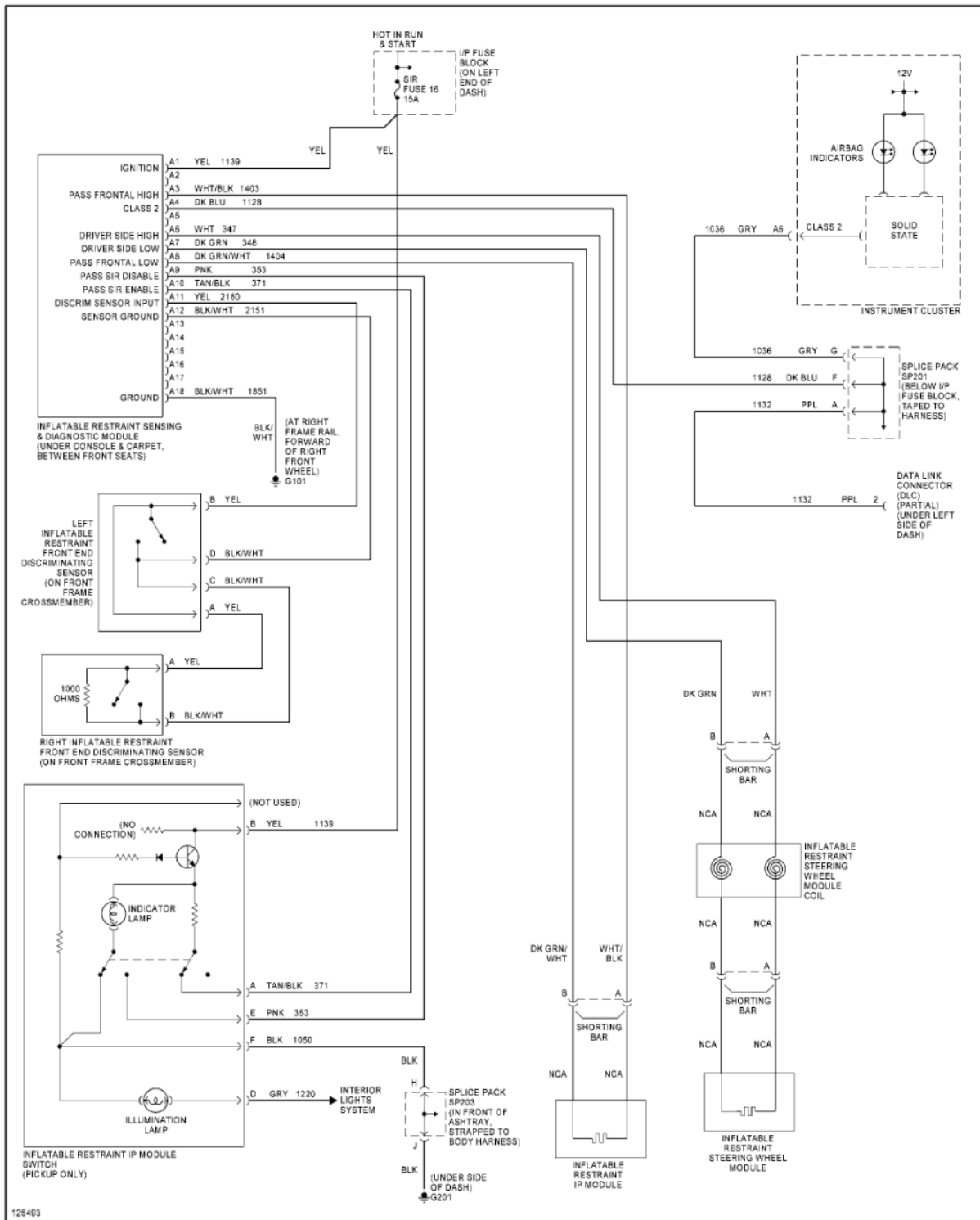

Fig. 57: Supplemental Restraint Circuit

TRANSMISSION

2.2L

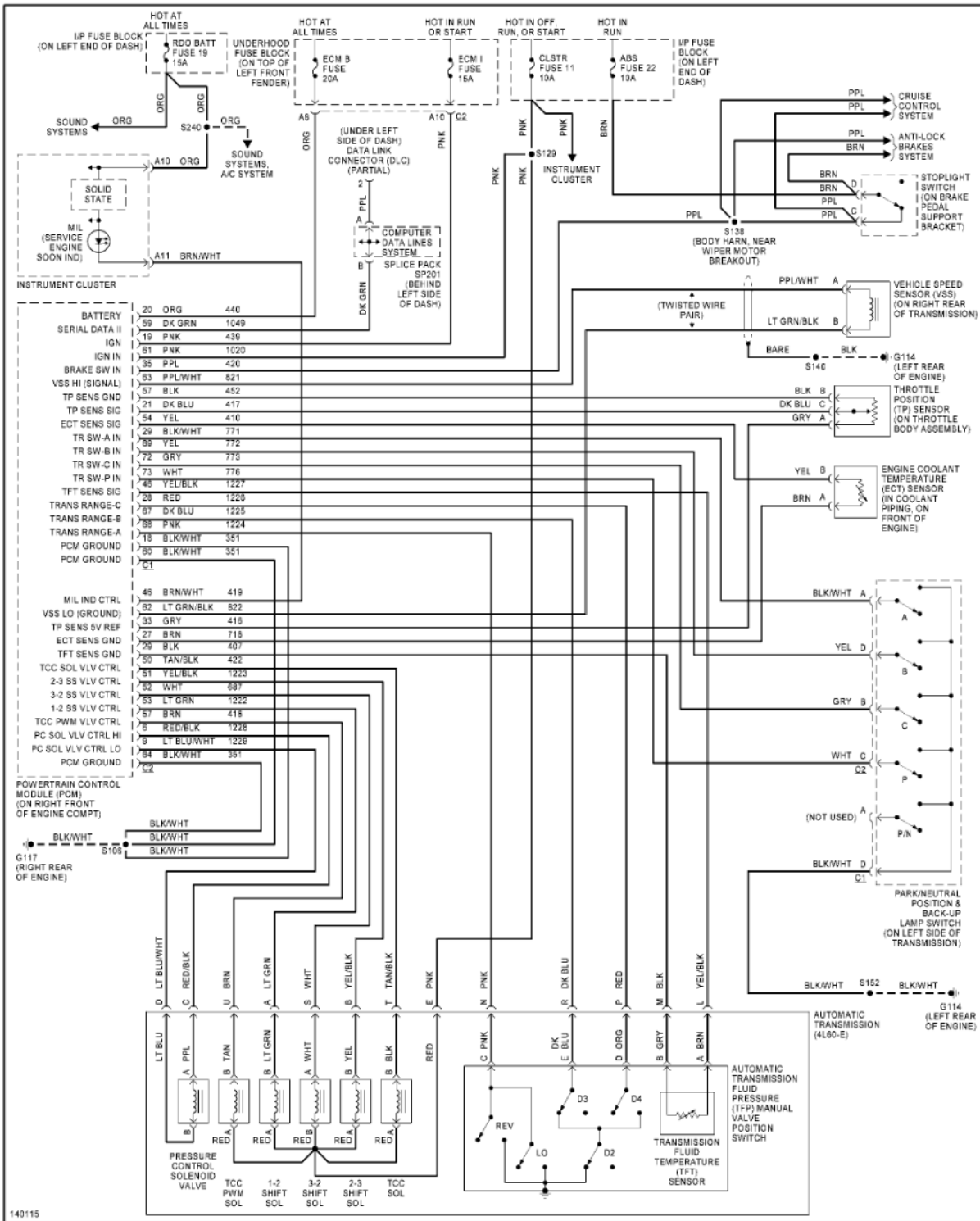

Fig. 58: 2.2L VIN 4, A/T Circuit, 4L60-E

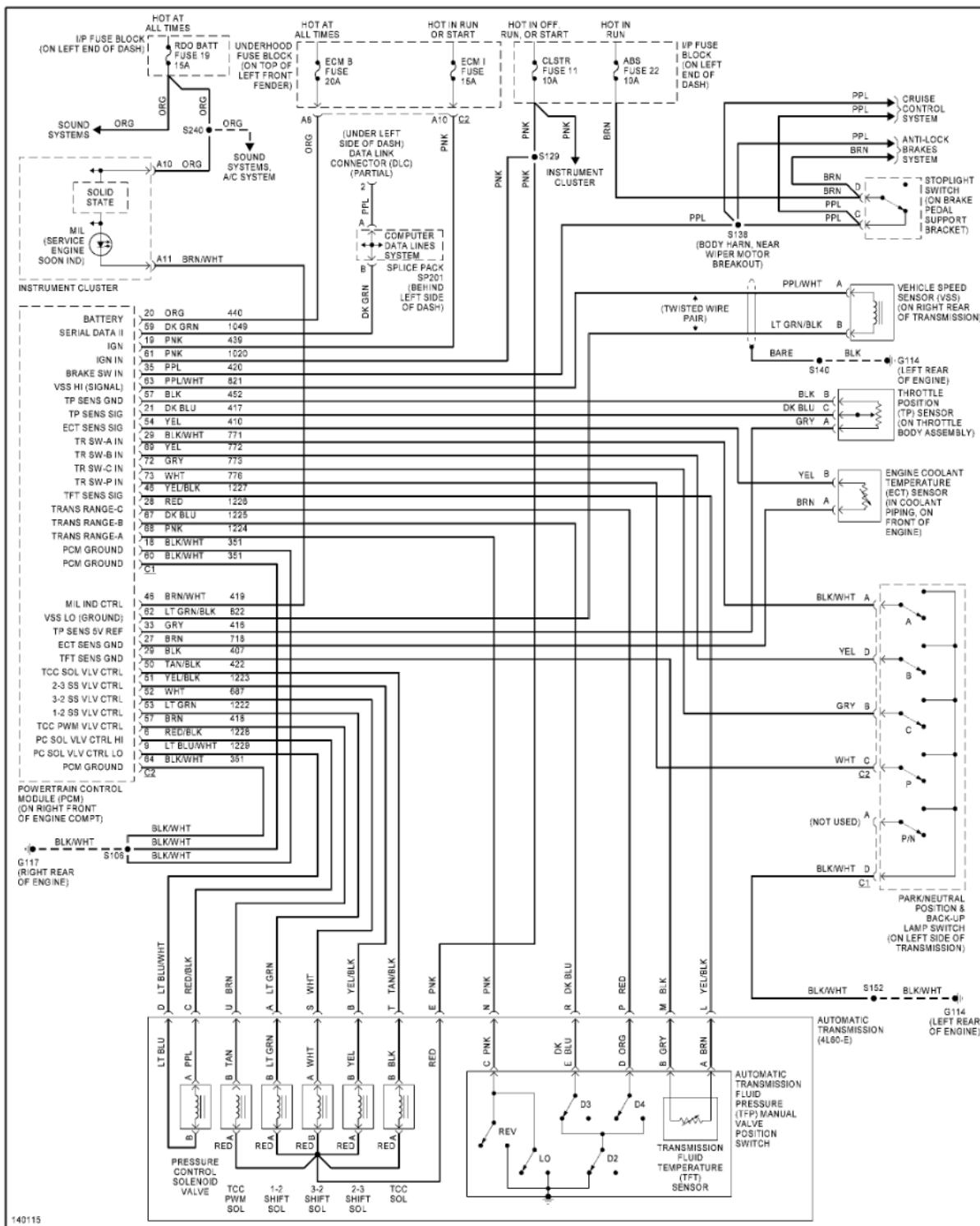

Fig. 59: 2.2L VIN 5, A/T Circuit, 4L60-E

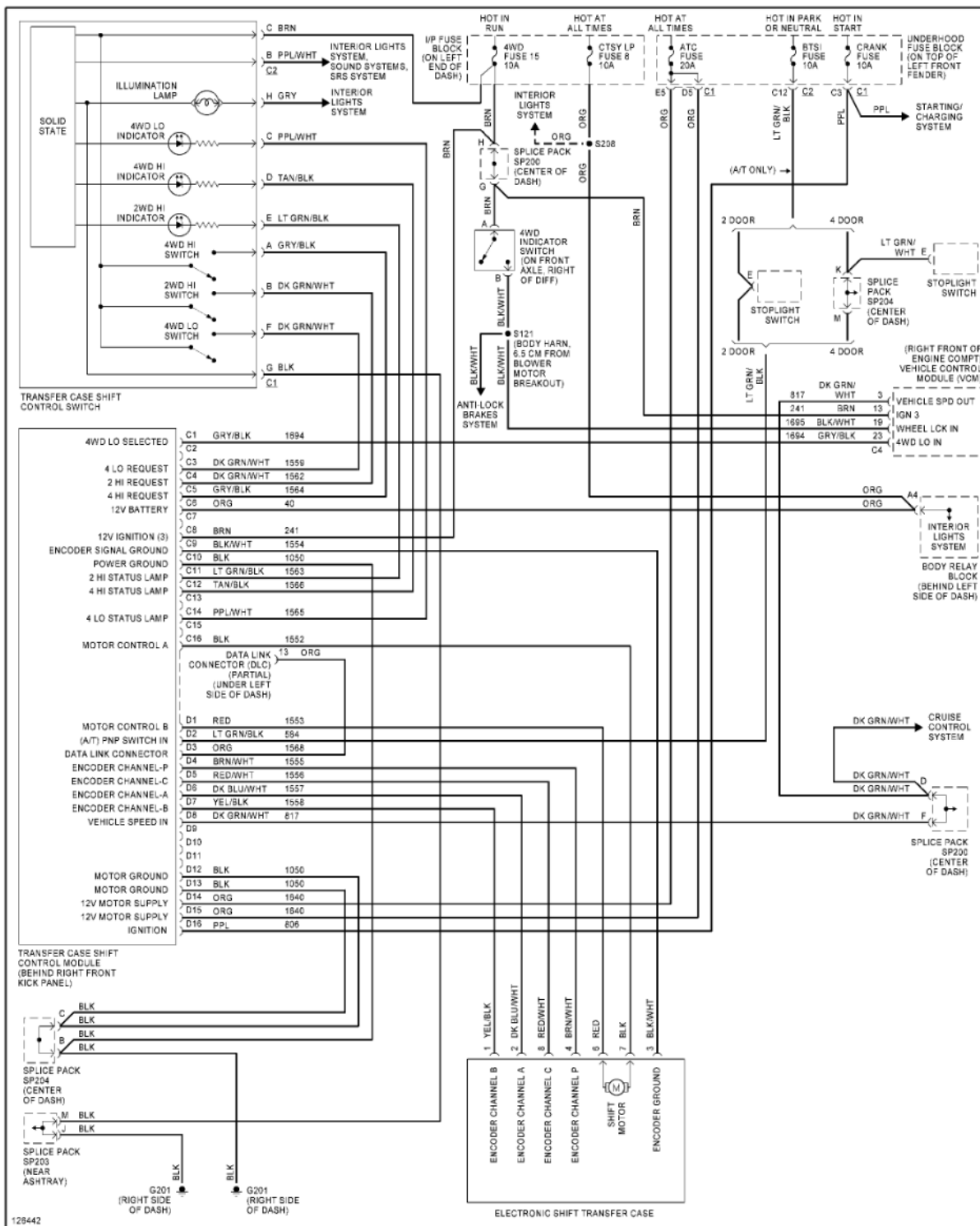

Fig. 60: 4WD Circuit, W/ 2-Speed Selectable Transfer Case

4.3L

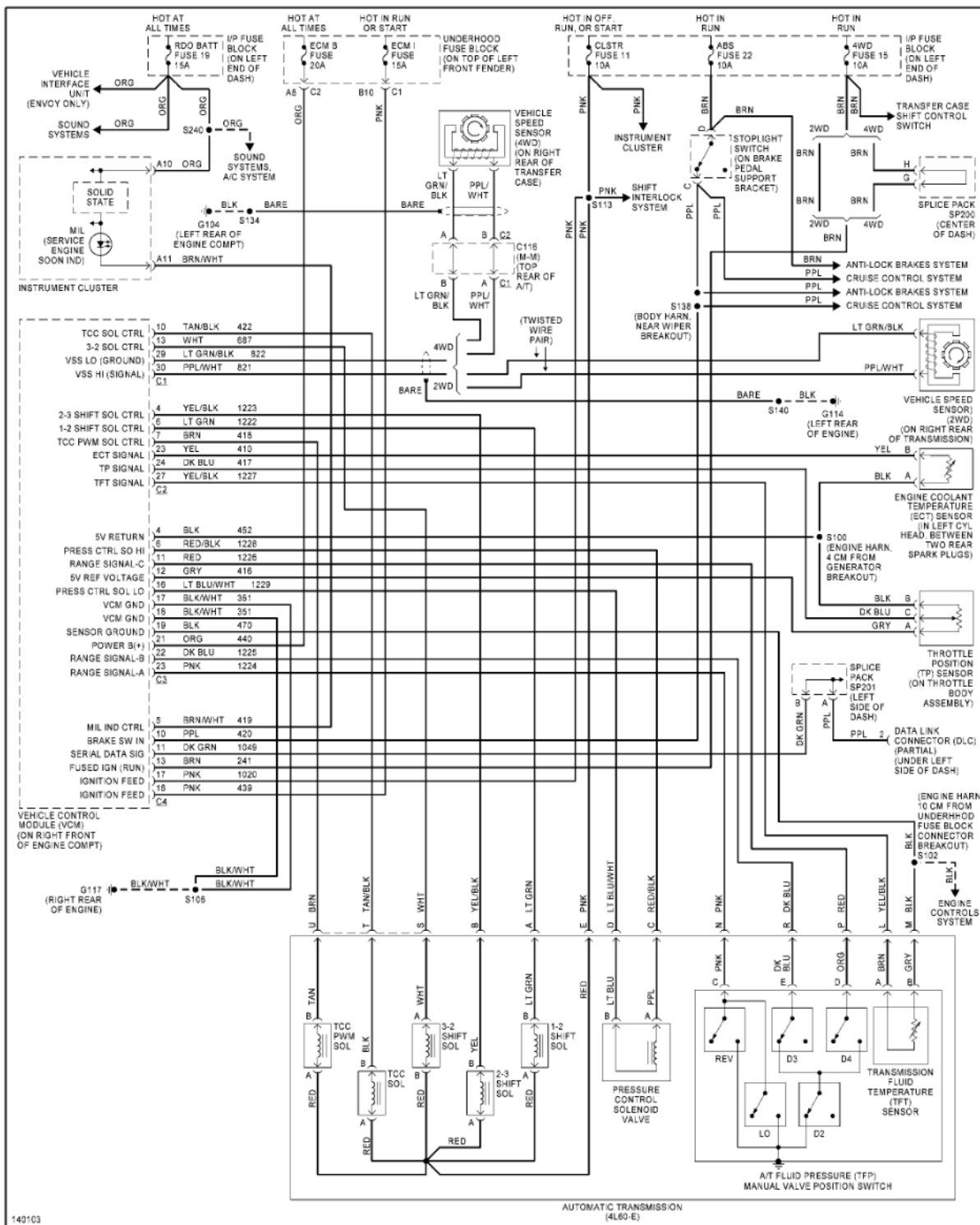

Fig. 61: 4.3L VIN W, A/T Circuit, 4L60-E

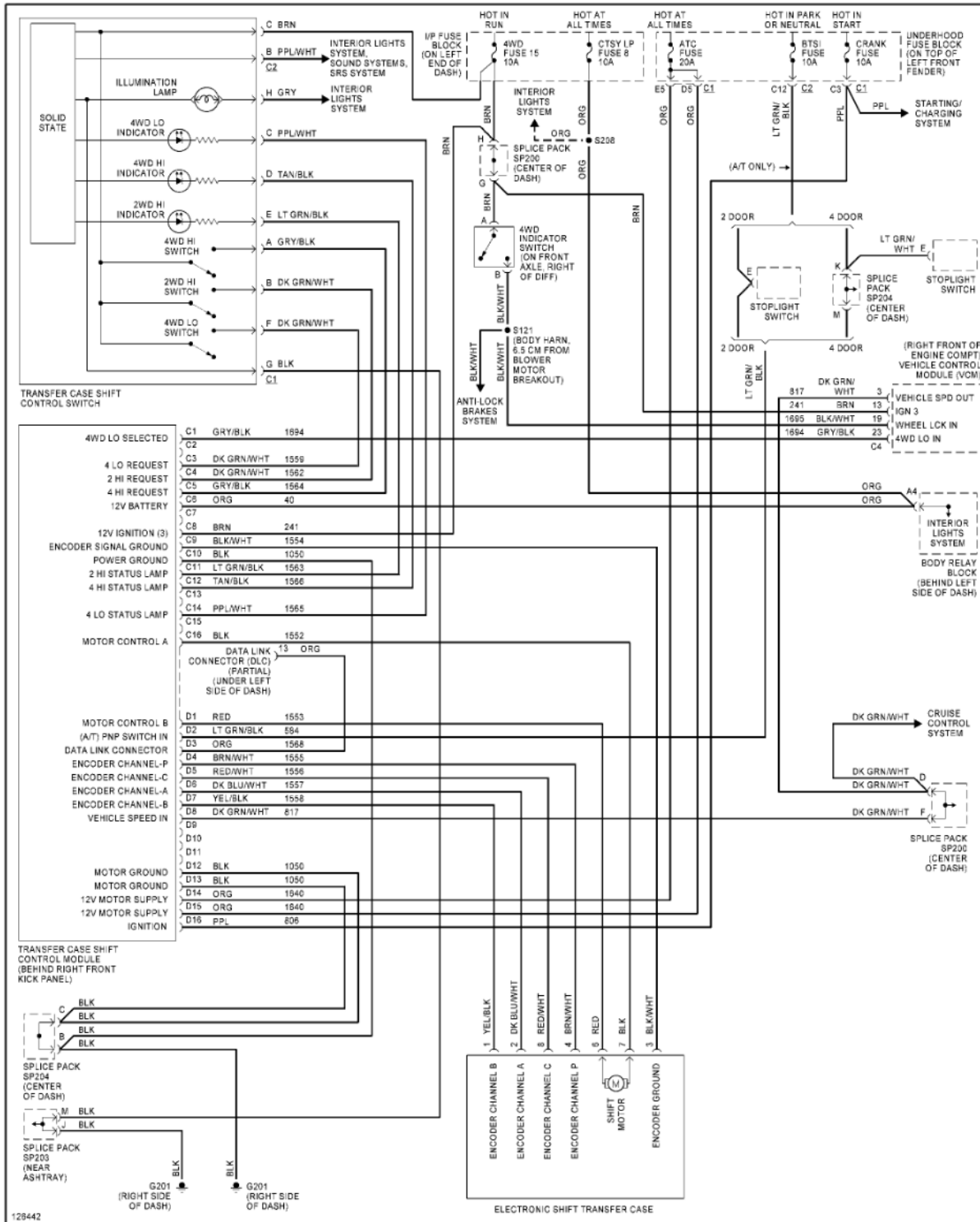

Fig. 62: 4WD Circuit, W/ 2-Speed Selectable Transfer Case

WARNING SYSTEMS

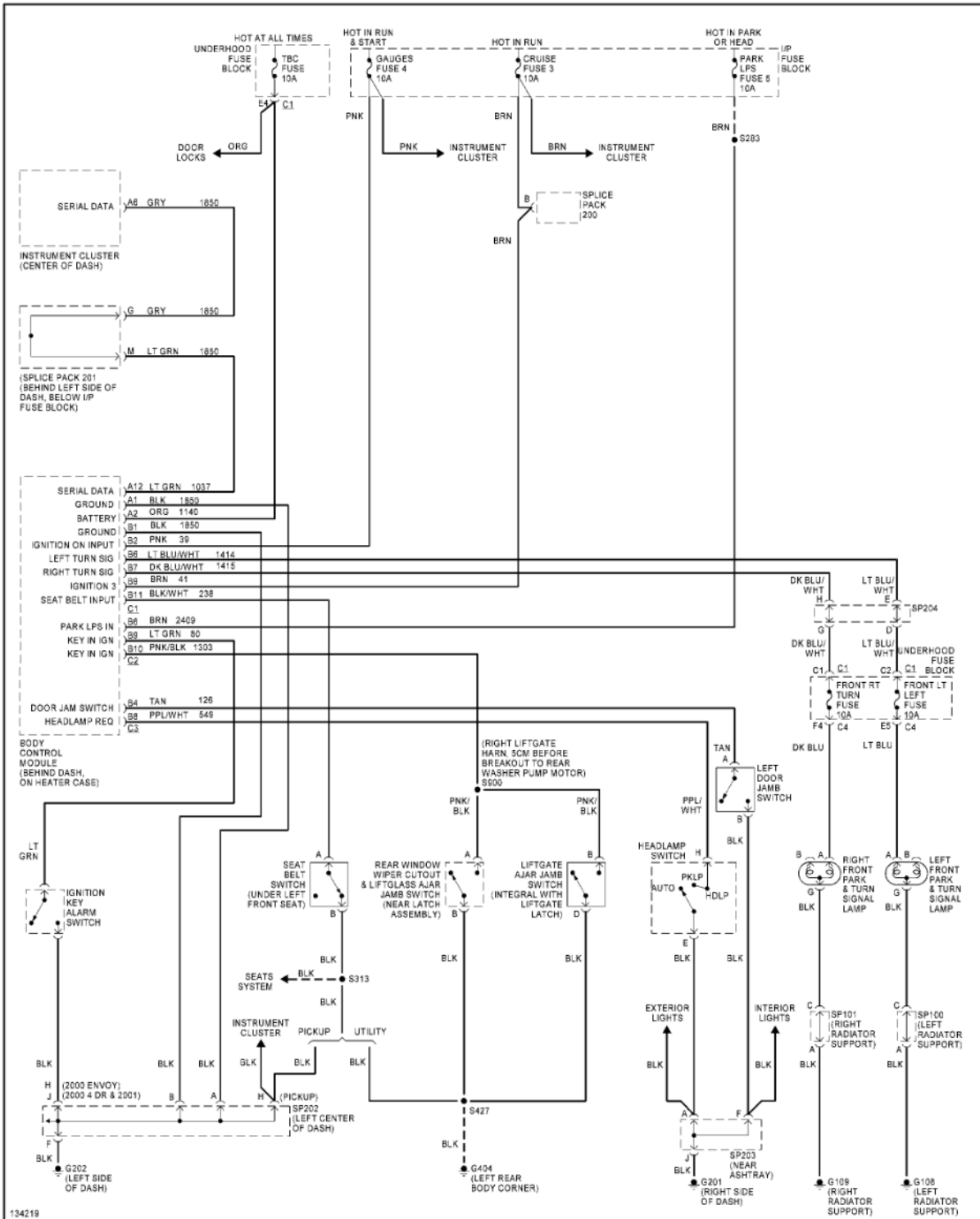

Fig. 63: Warning System Circuits

WIPER/WASHER

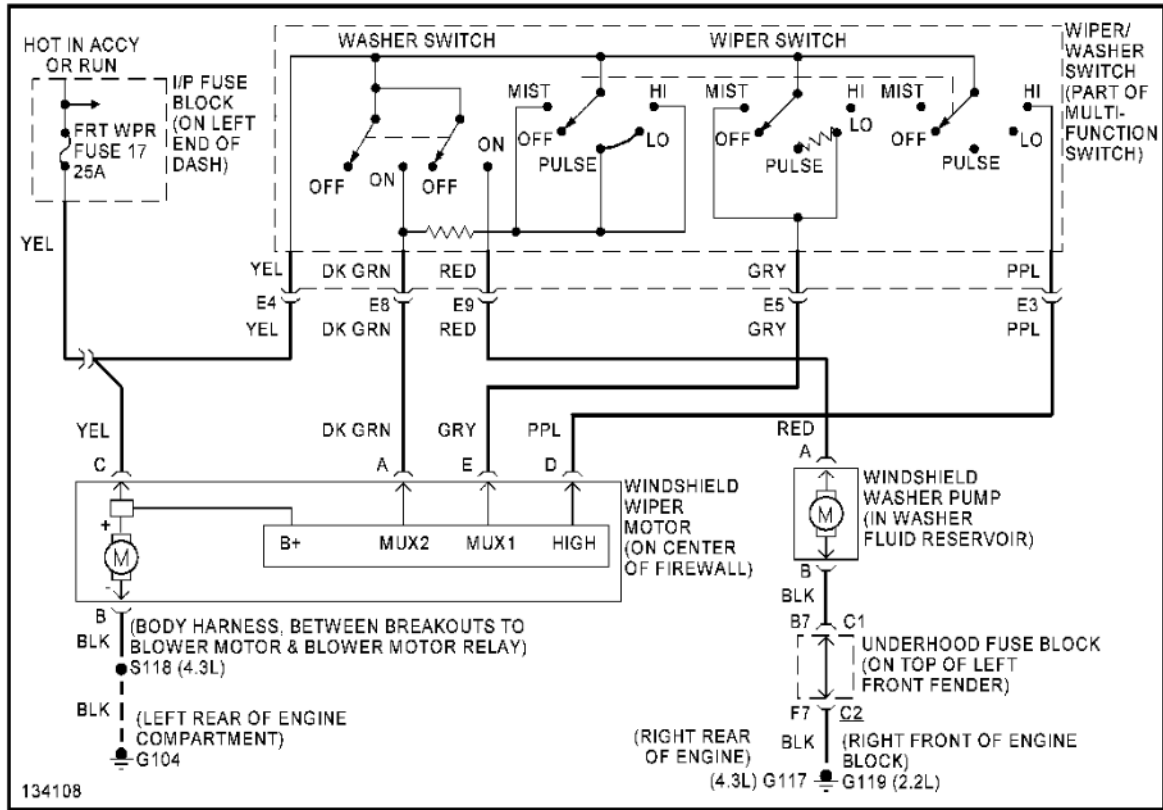

Fig. 64: Wiper/Washer Circuit

© 2008 Mitchell Repair Information Co., LLC.