

ARTICLE BEGINNING 

AIR CONDITIONING 

2.2L 

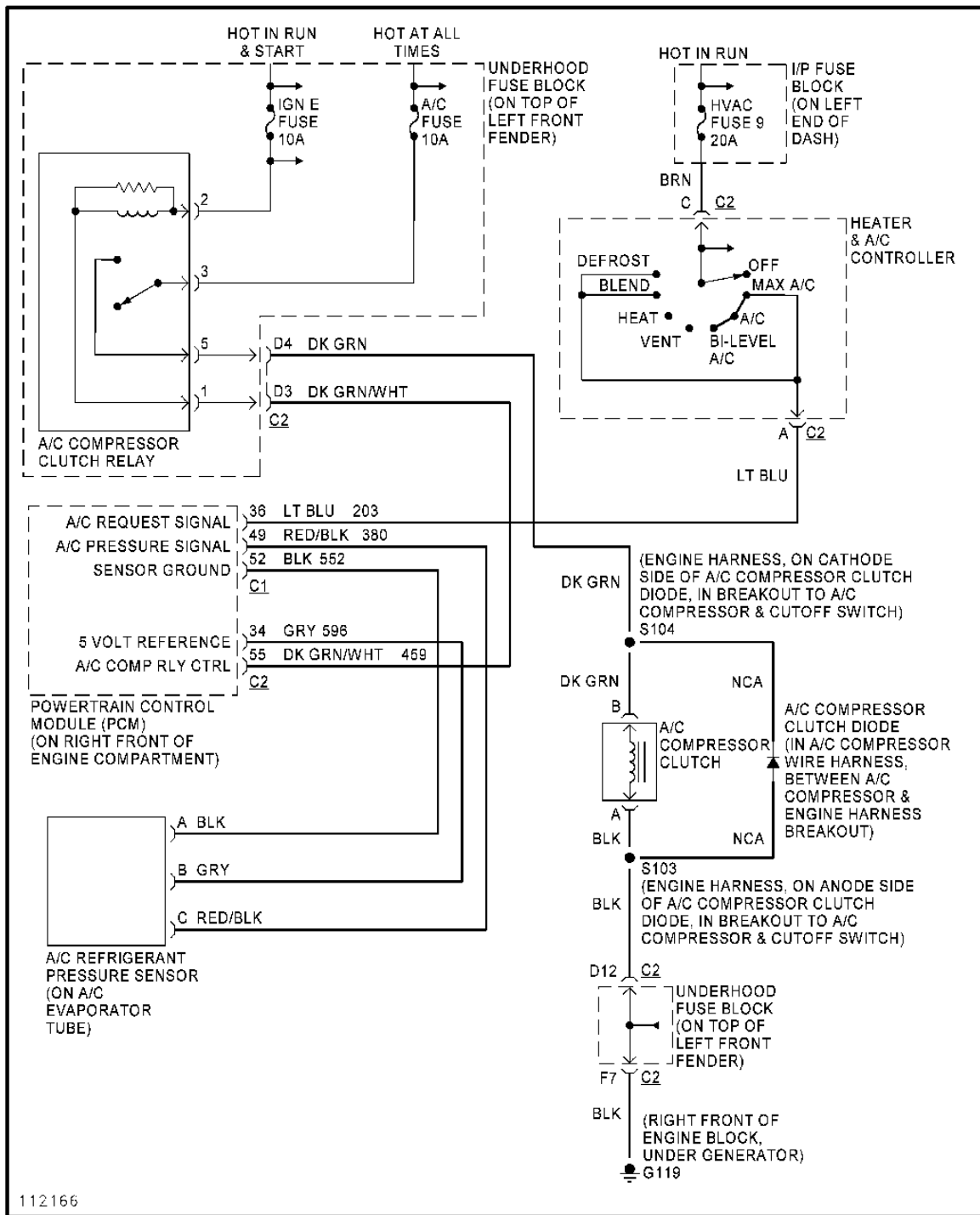

Fig. 1: 2.2L VIN 4, Compressor Circuit

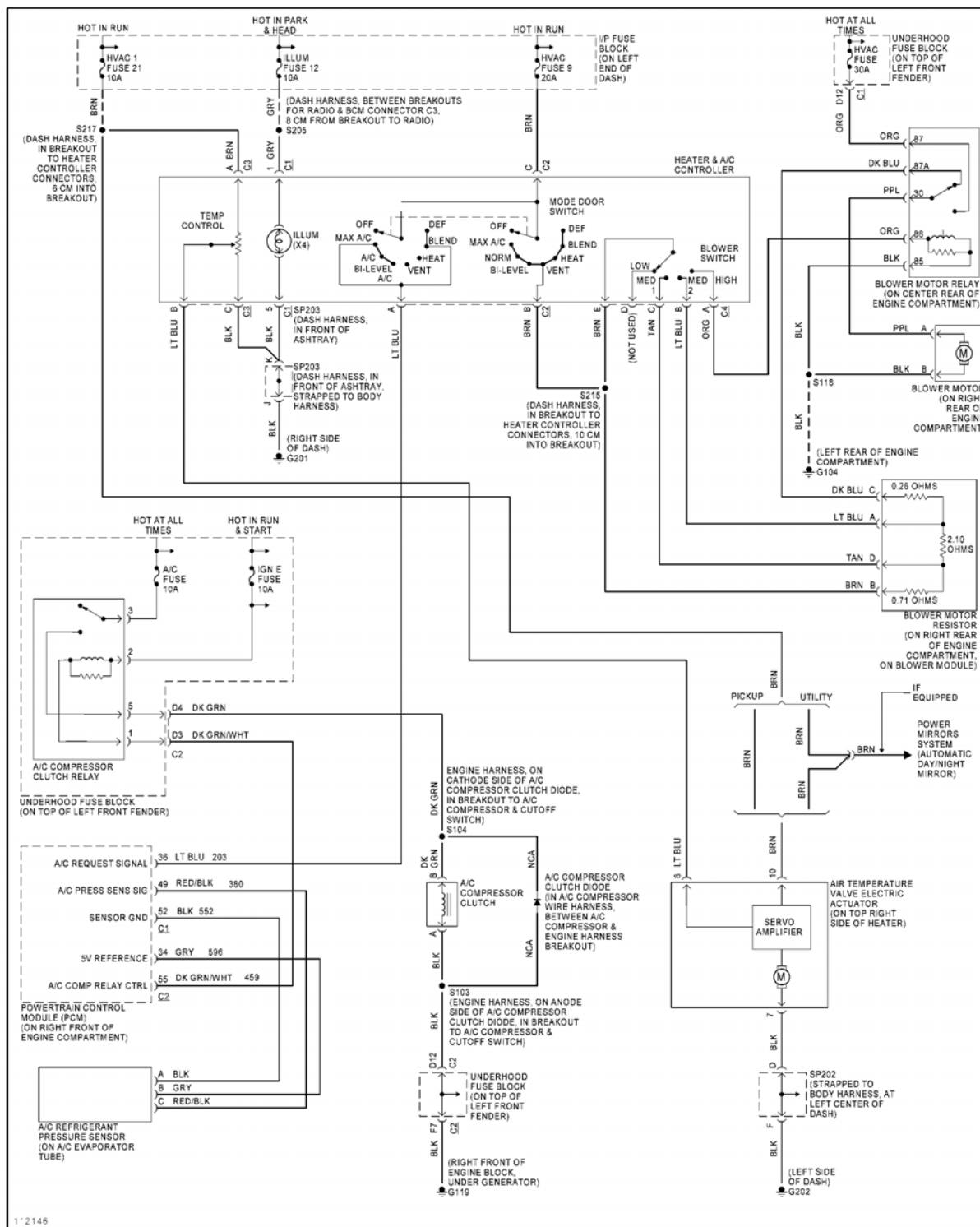

Fig. 2: 2.2L VIN 4, Manual A/C Circuit

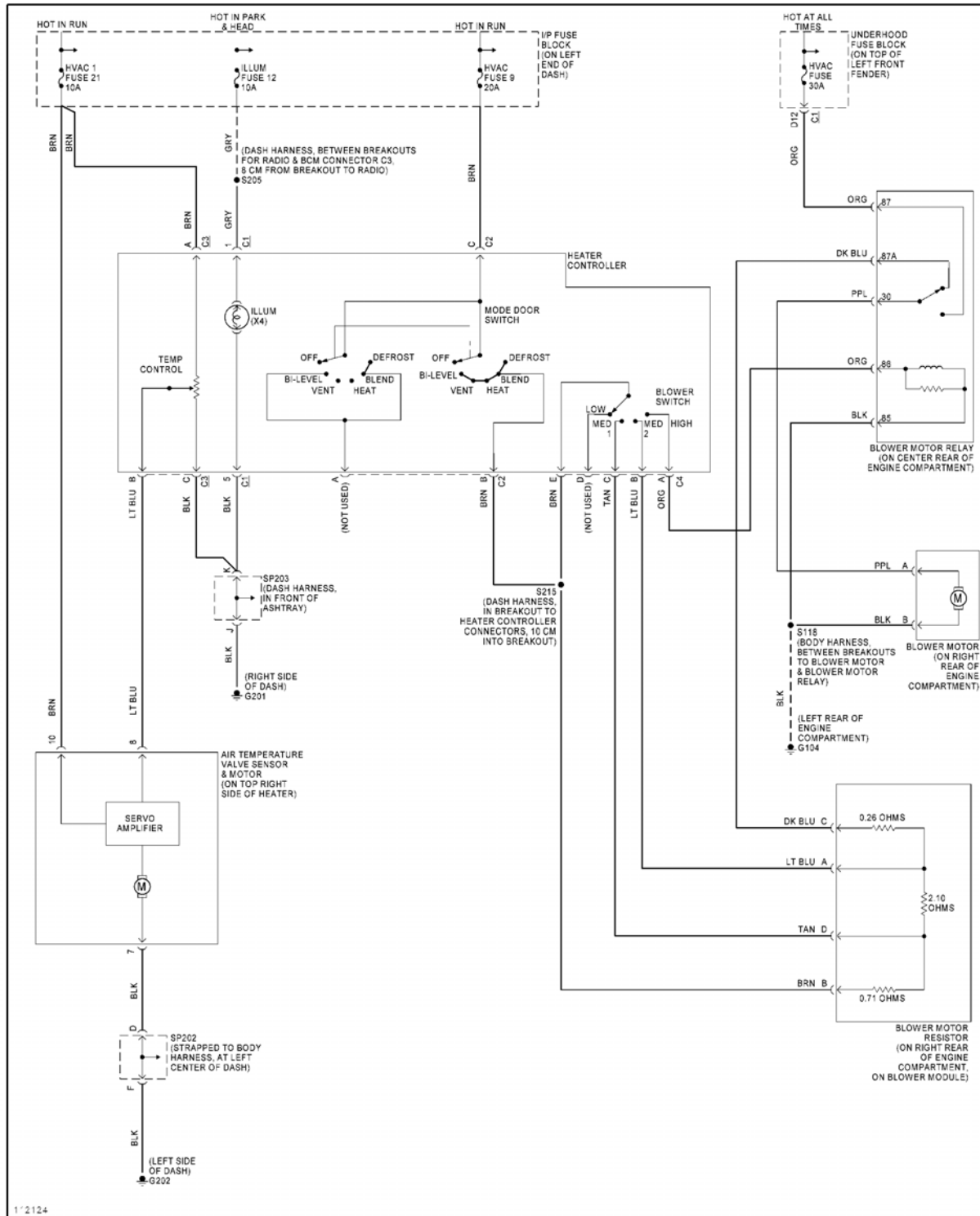



Fig. 3: Heater Circuit

4.3L 

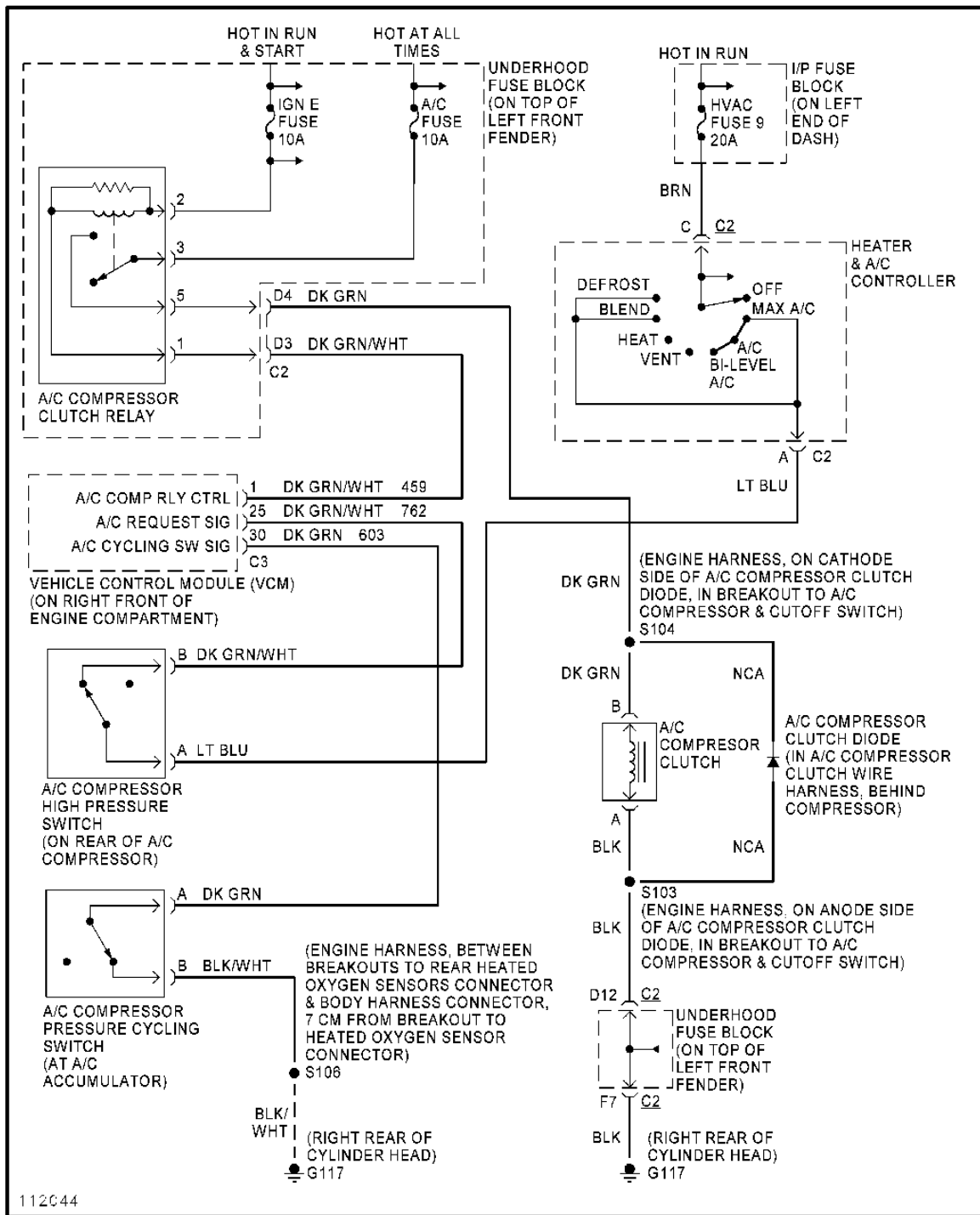

Fig. 4: 4.3L VIN W, Compressor Circuit, Manual A/C

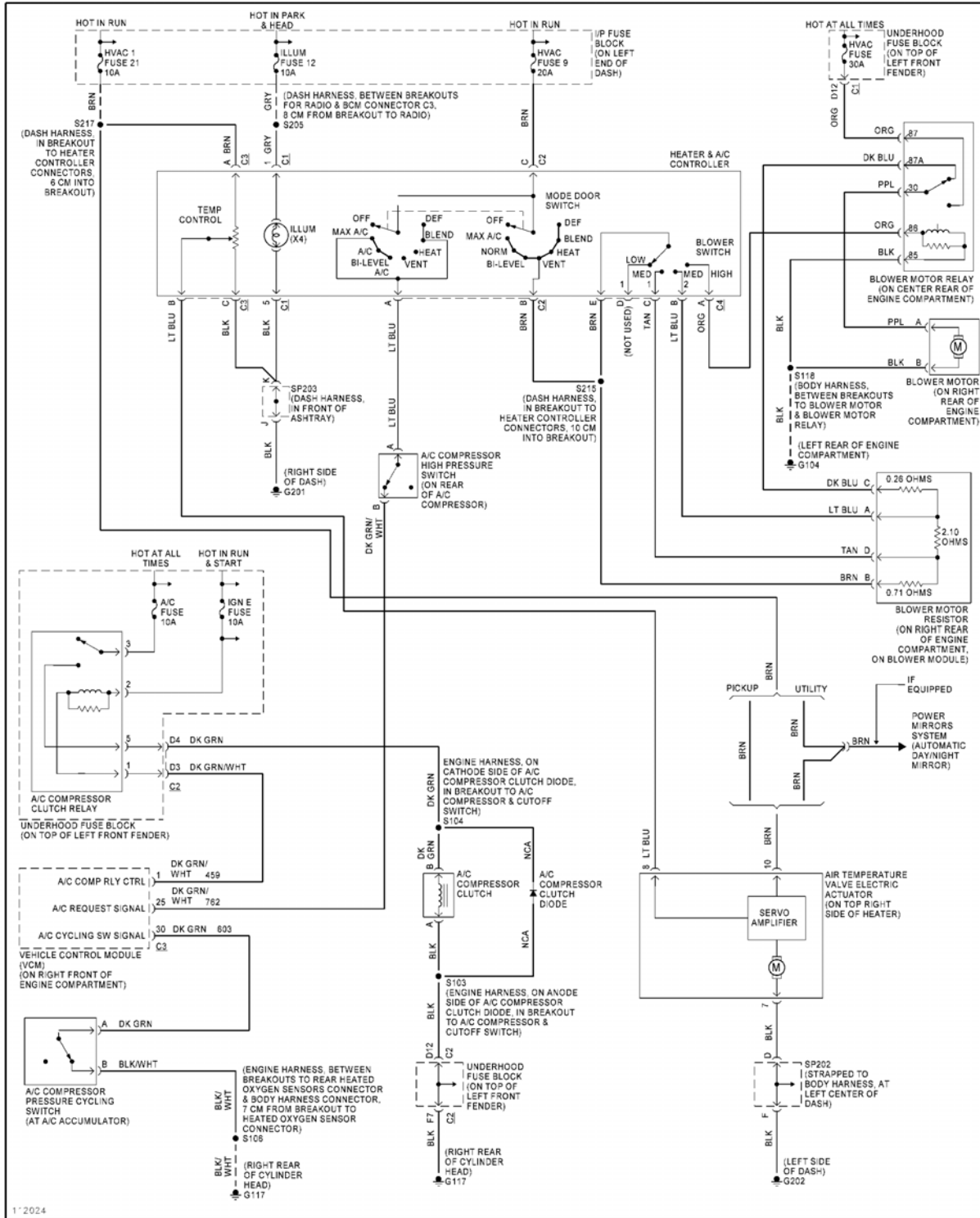

Fig. 5: 43L VIN W, Manual A/C Circuit

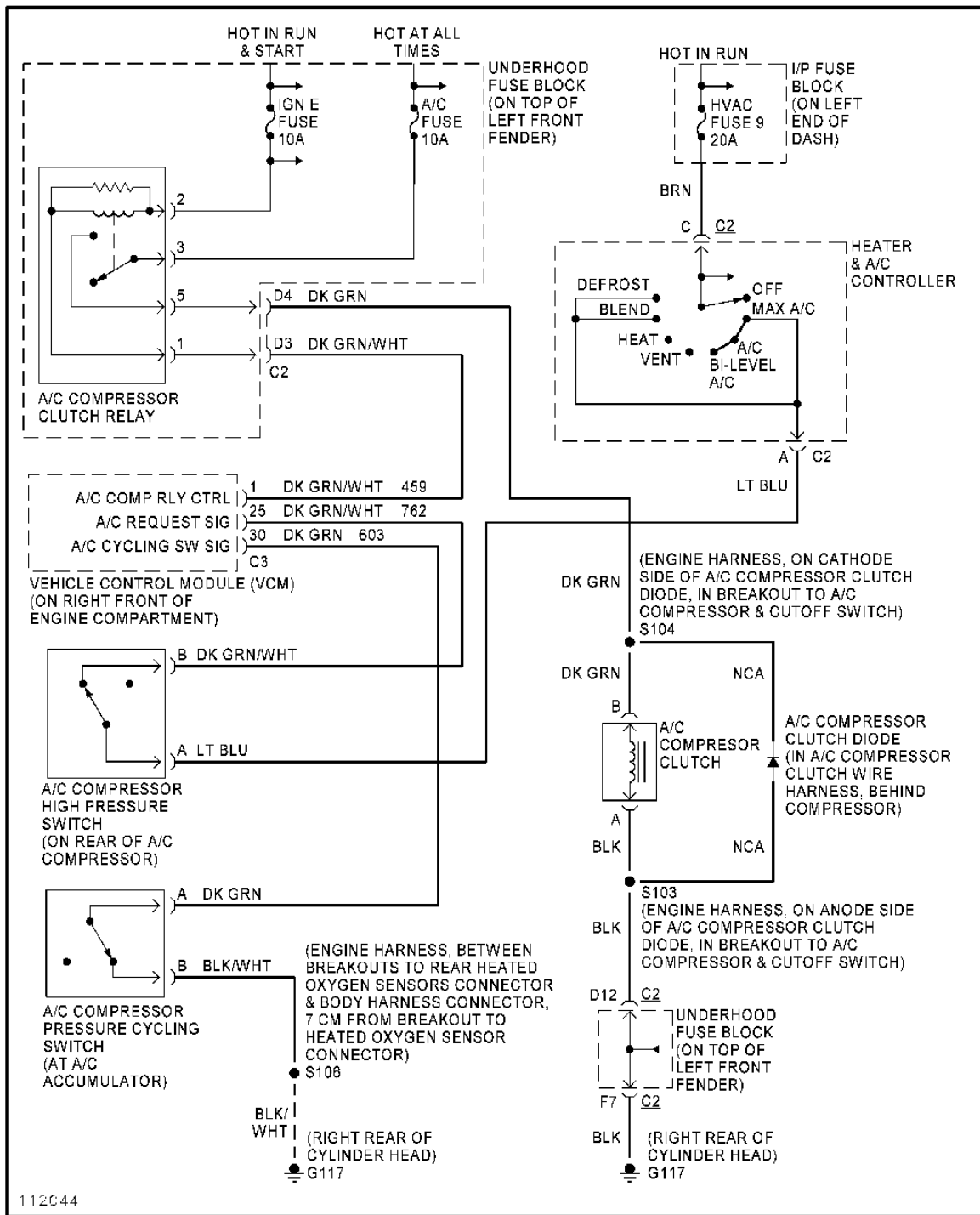

Fig. 6: 4.3L VIN X, Compressor Circuit, Manual A/C

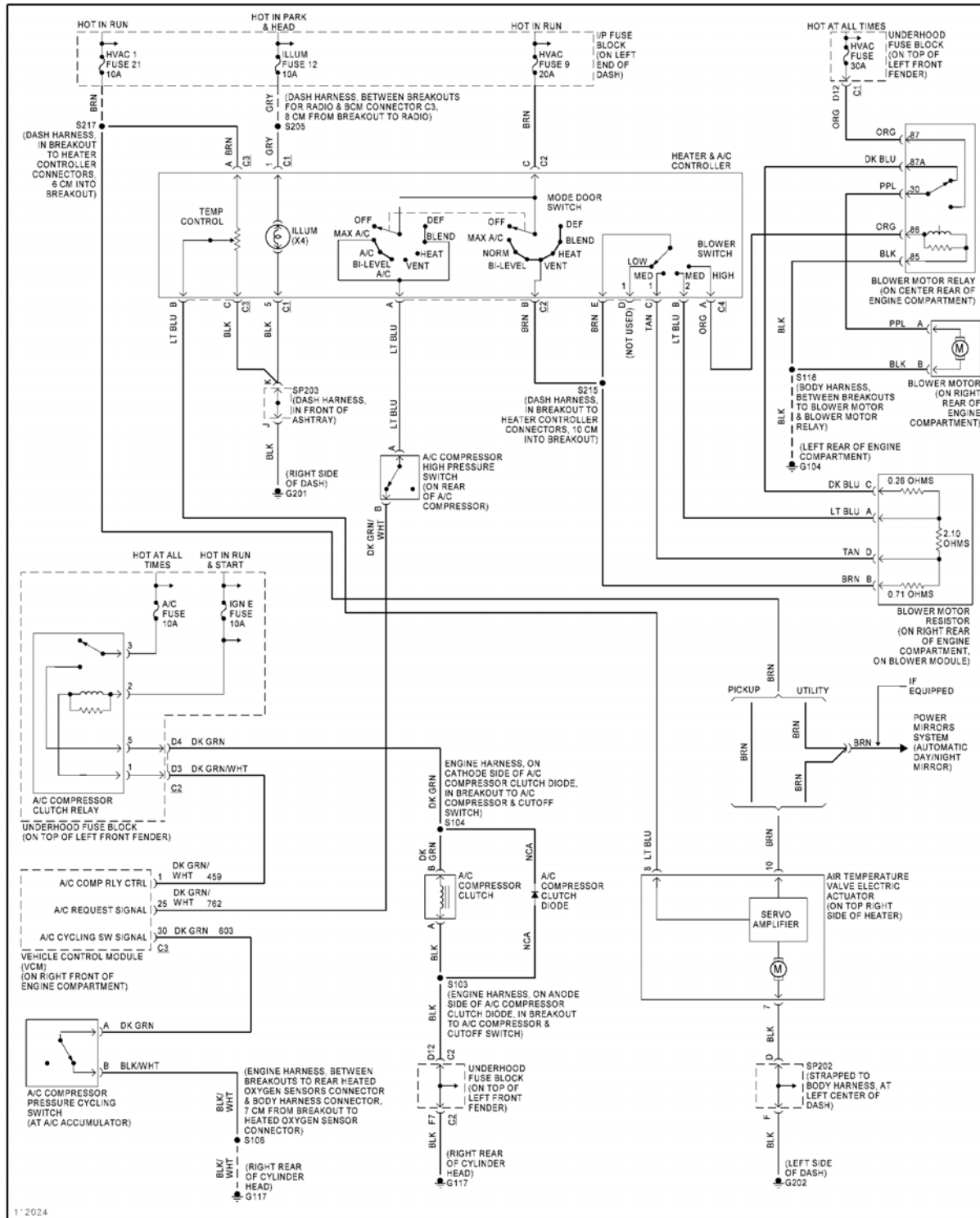

Fig. 7: 43L VIN X, Manual A/C Circuit

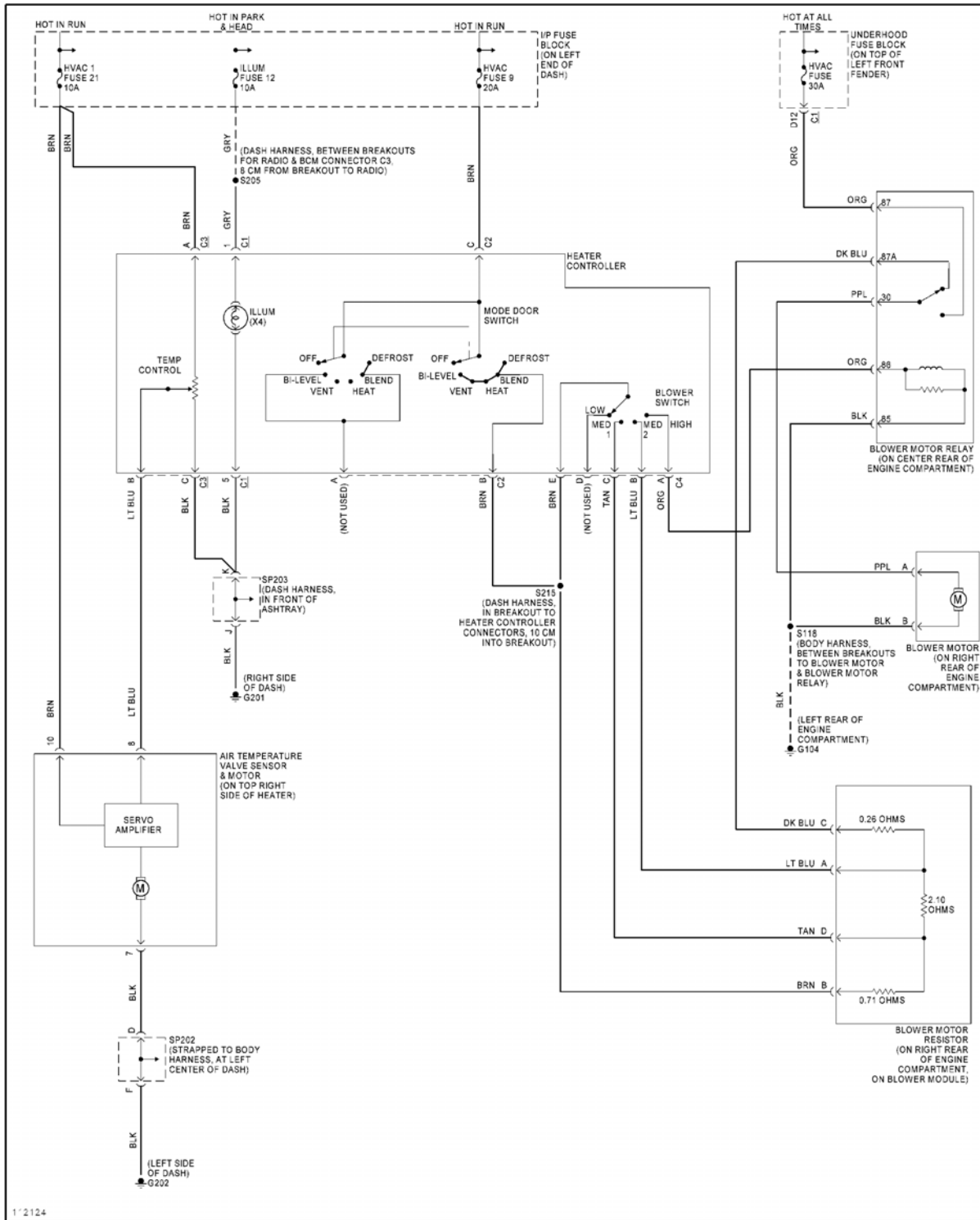

Fig. 8: Heater Circuit

ANTI-LOCK BRAKES 

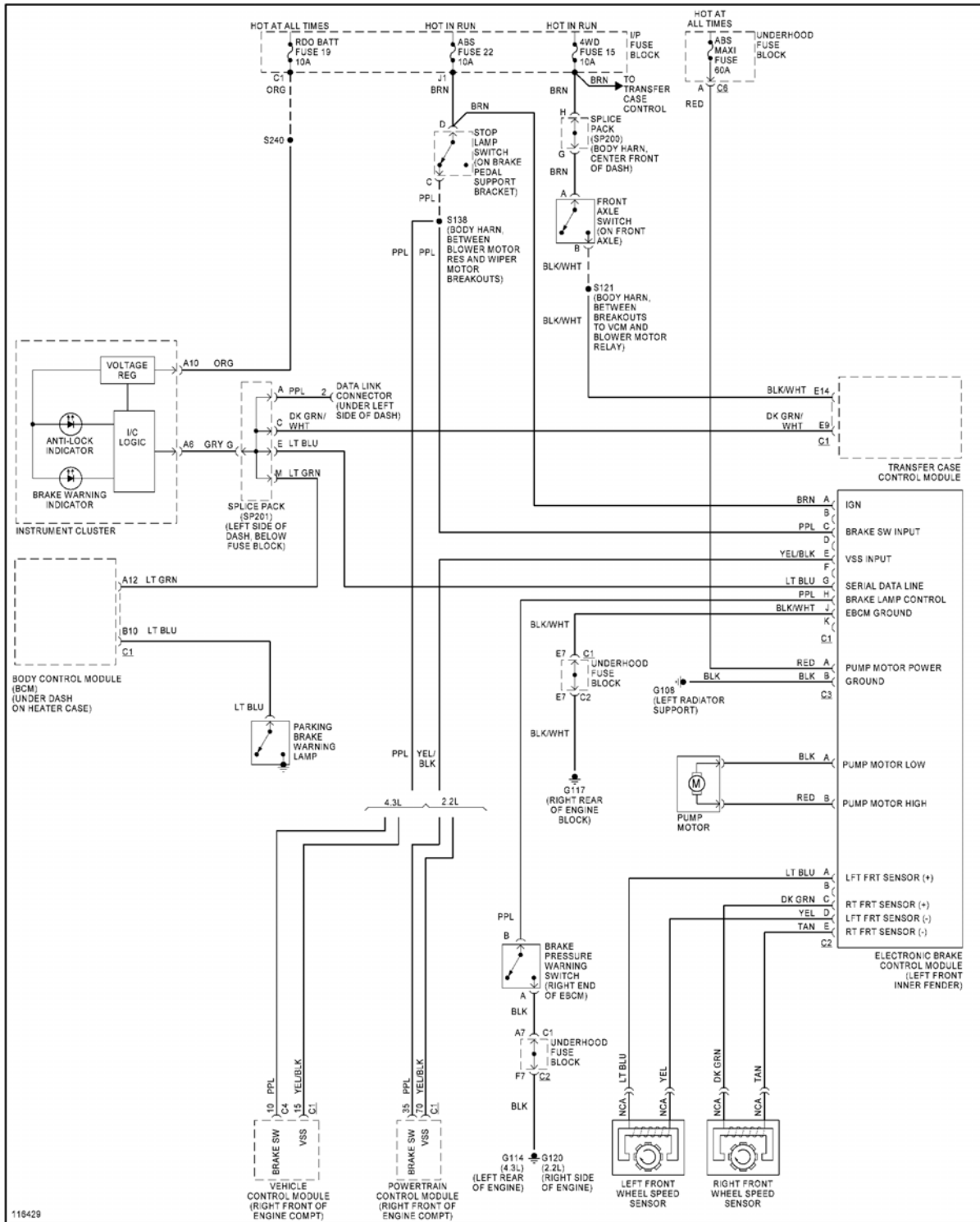

Fig. 9: Anti-lock Brake Circuits

ANTI-THEFT 

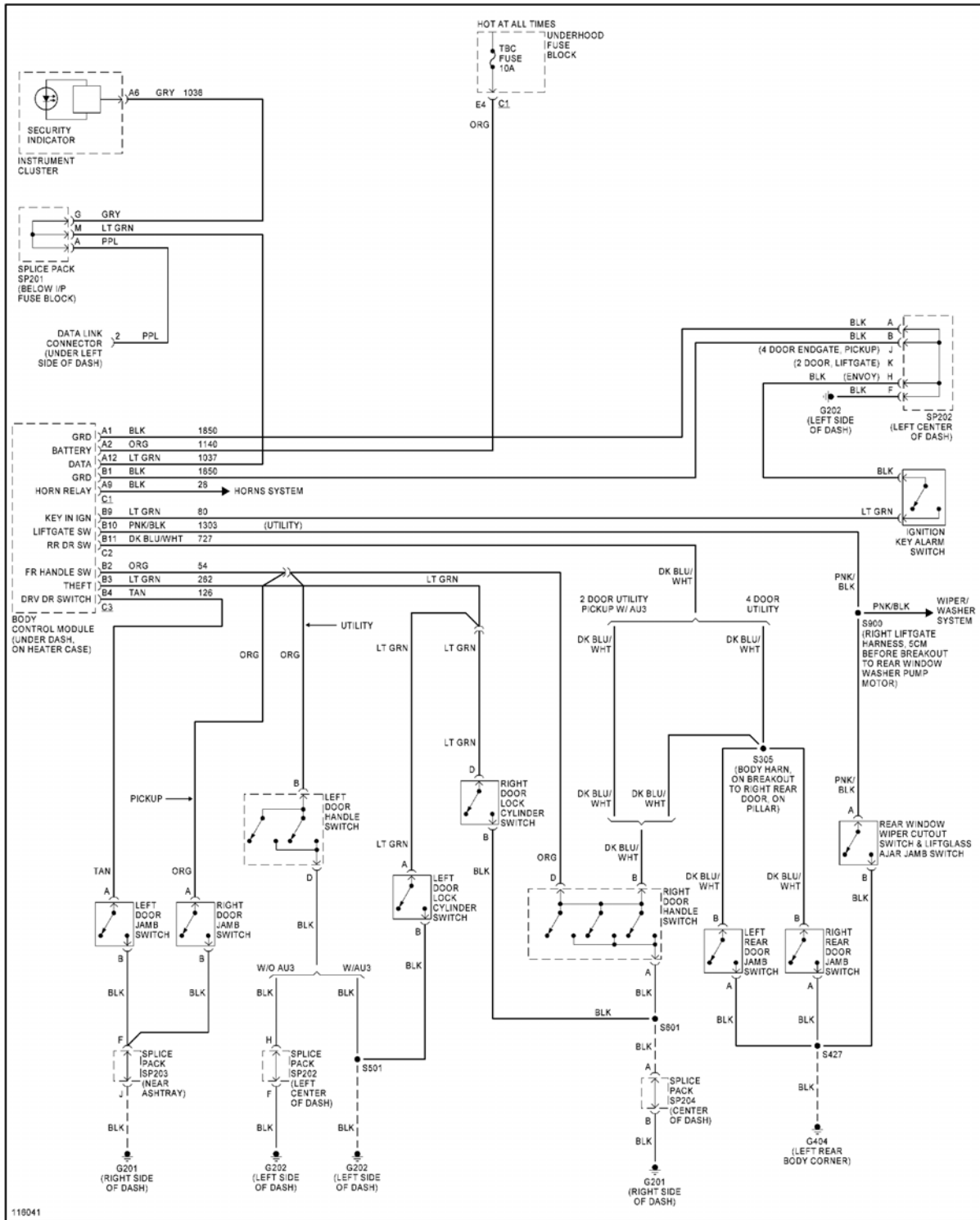

Fig. 10: Forced Entry Circuit

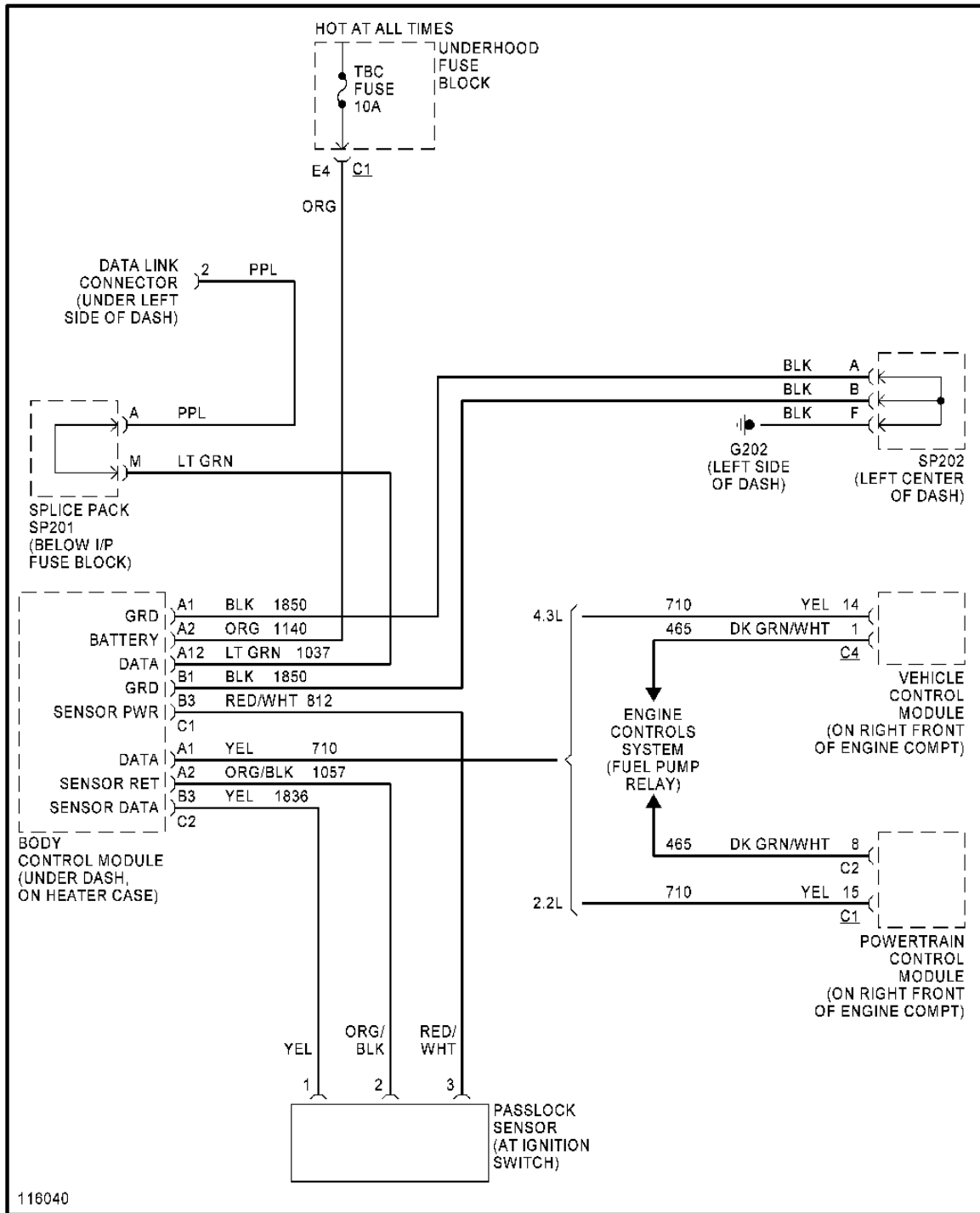

Fig. 11: Pass-Key Circuit

BODY COMPUTER 

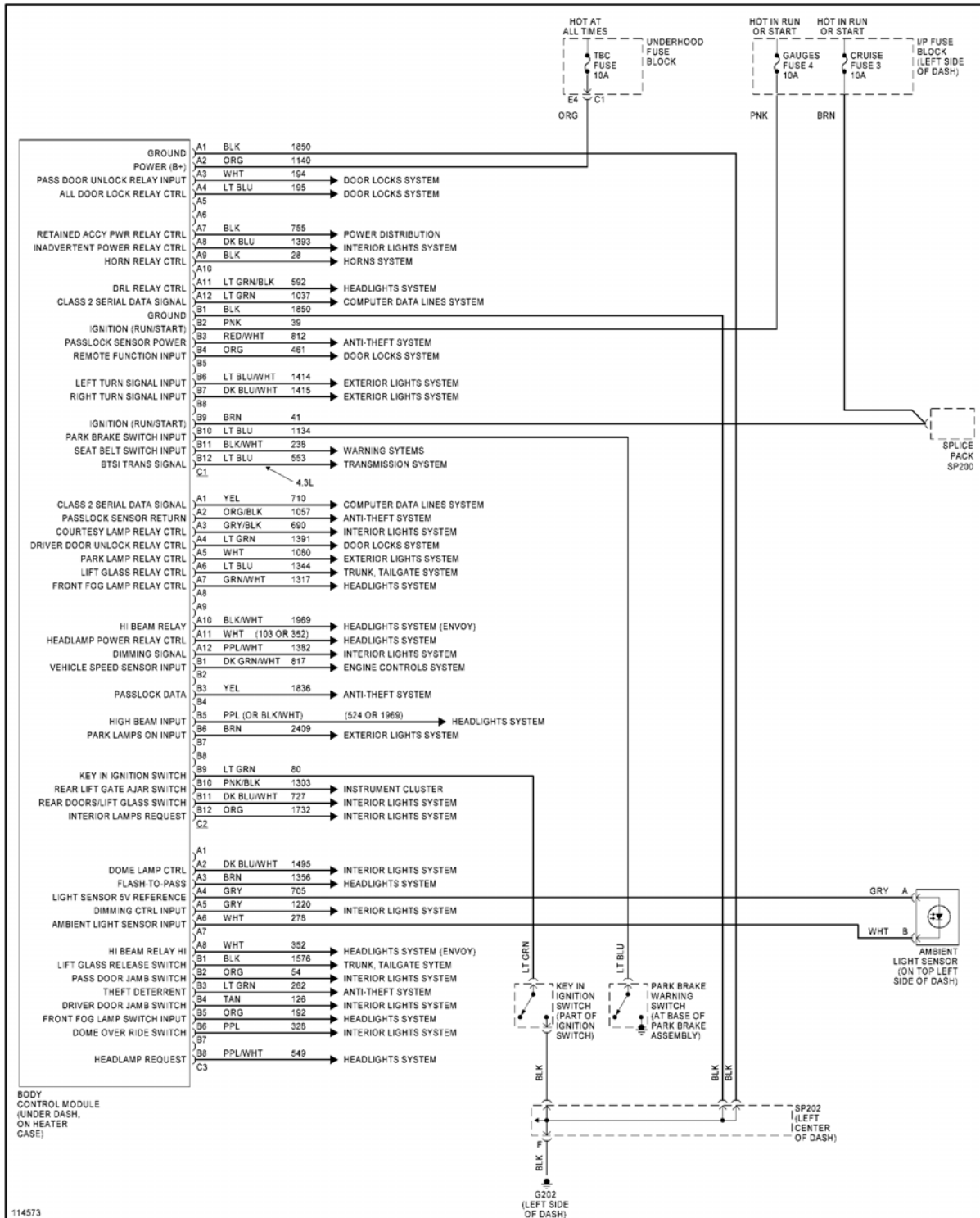

Fig. 12: Body Computer Circuits

COMPUTER DATA LINES

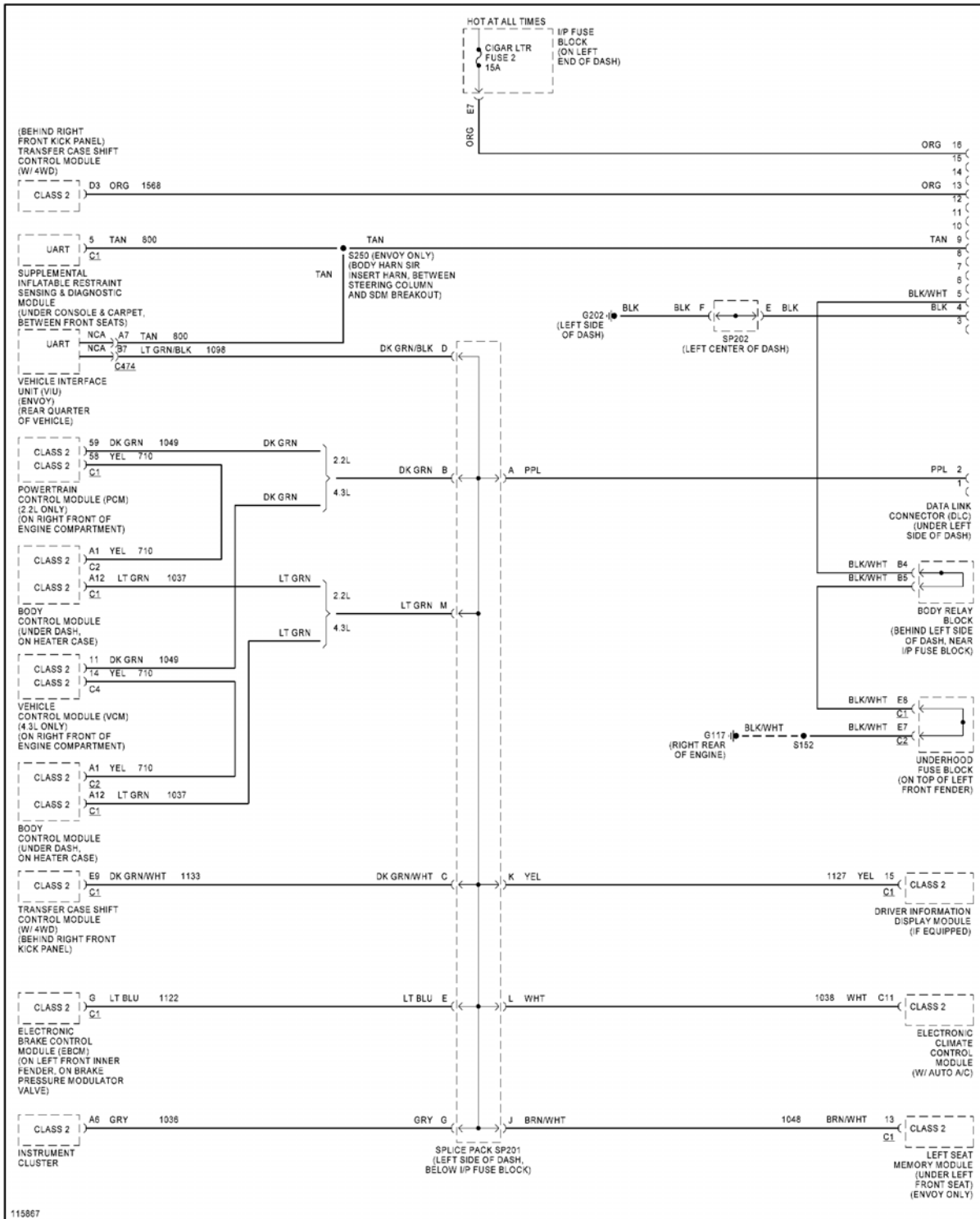

Fig. 13: Computer Data Lines

CRUISE CONTROL 

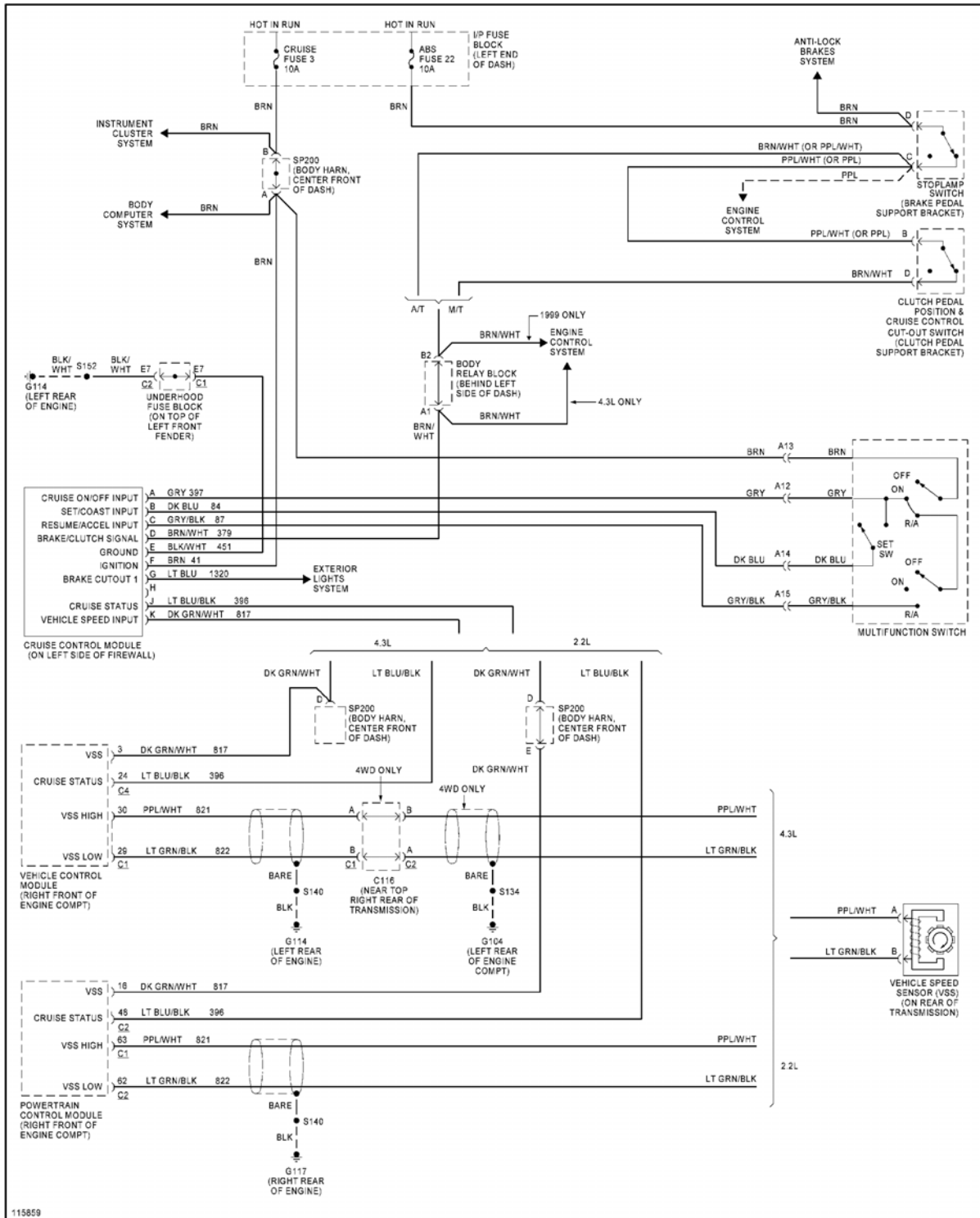

Fig. 14: Cruise Control Circuit



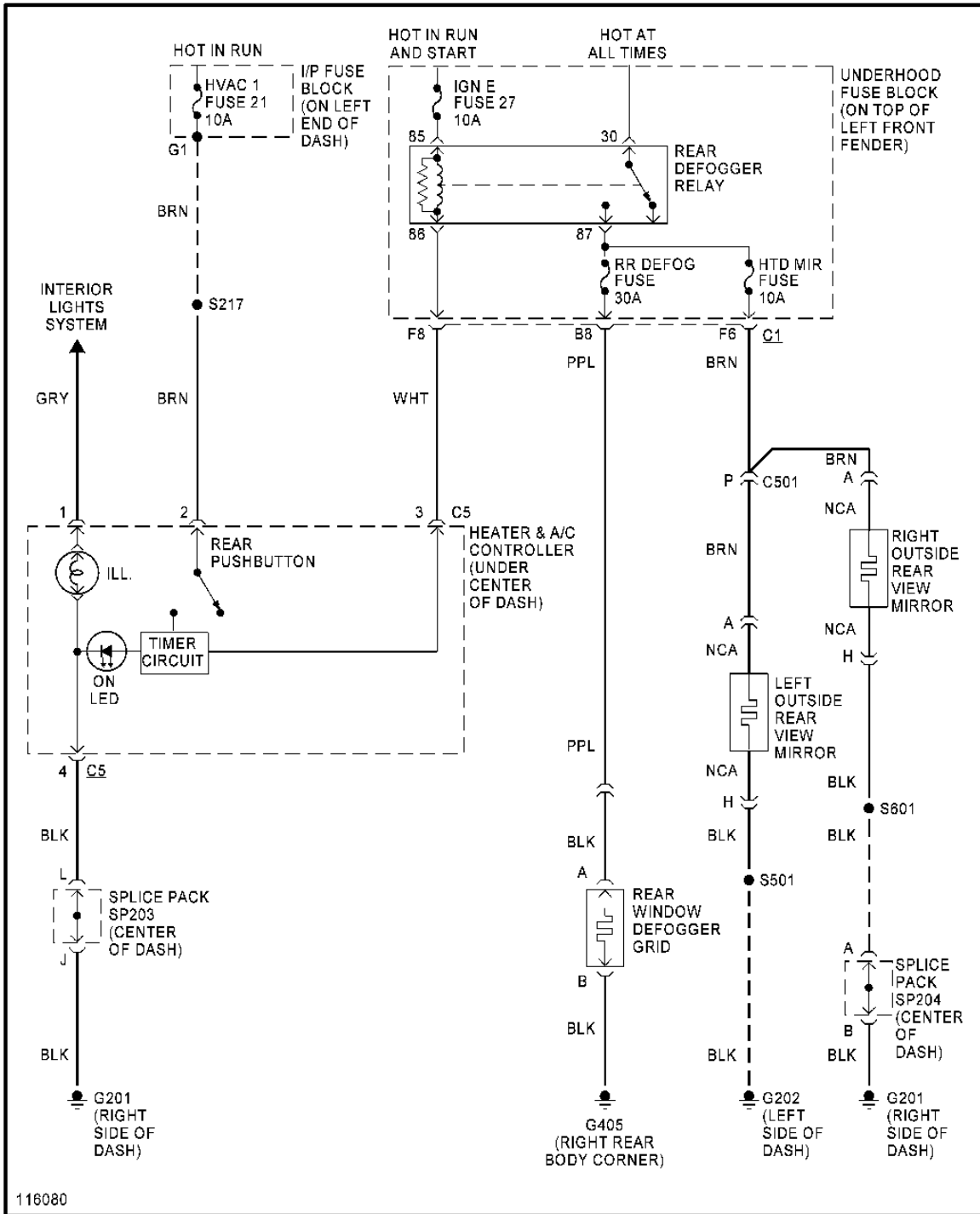

Fig. 15: Defogger Circuit

ENGINE PERFORMANCE 

2.2L 

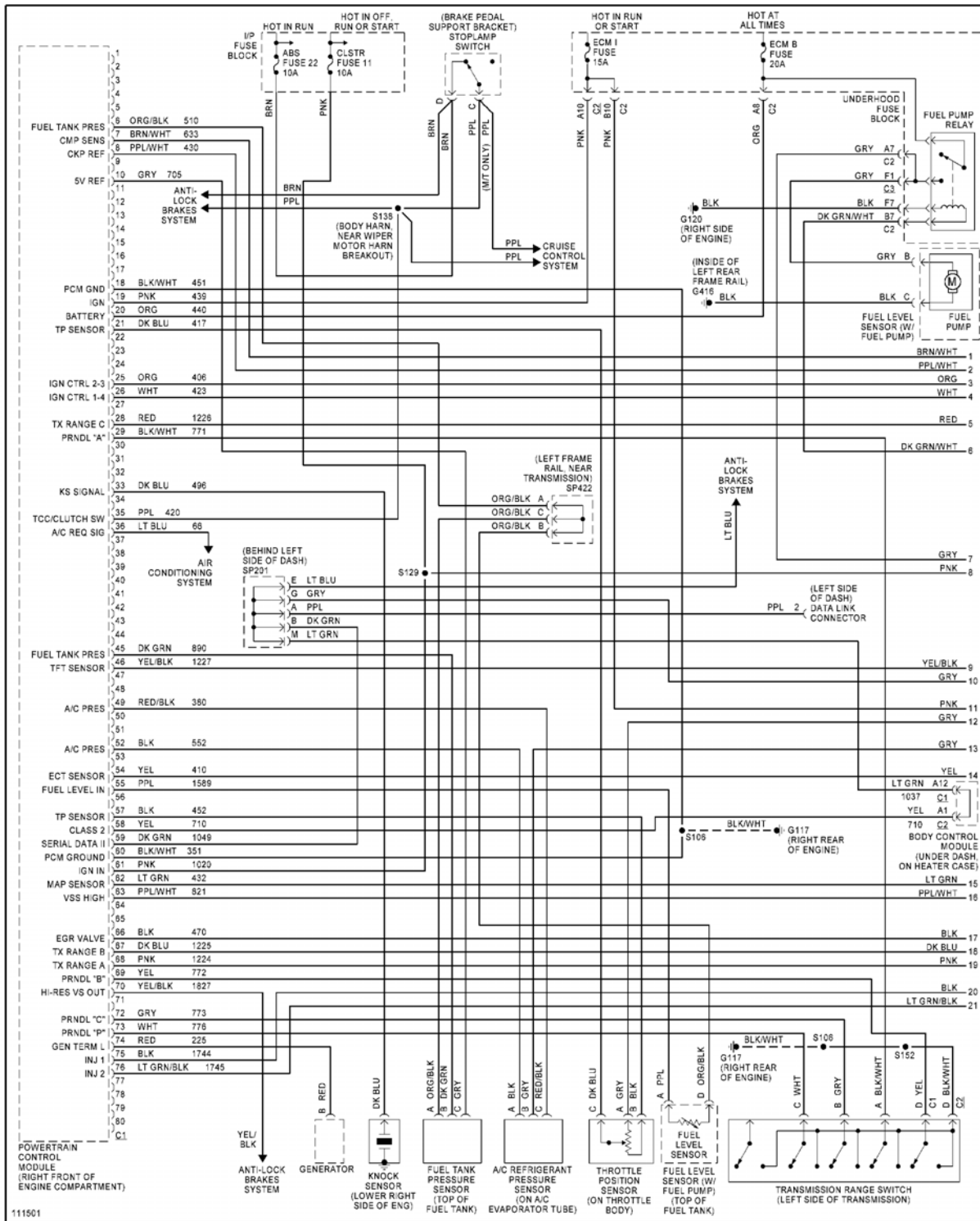

Fig. 16: 2.2L VIN 4, Engine Performance Circuits (1 of 3)

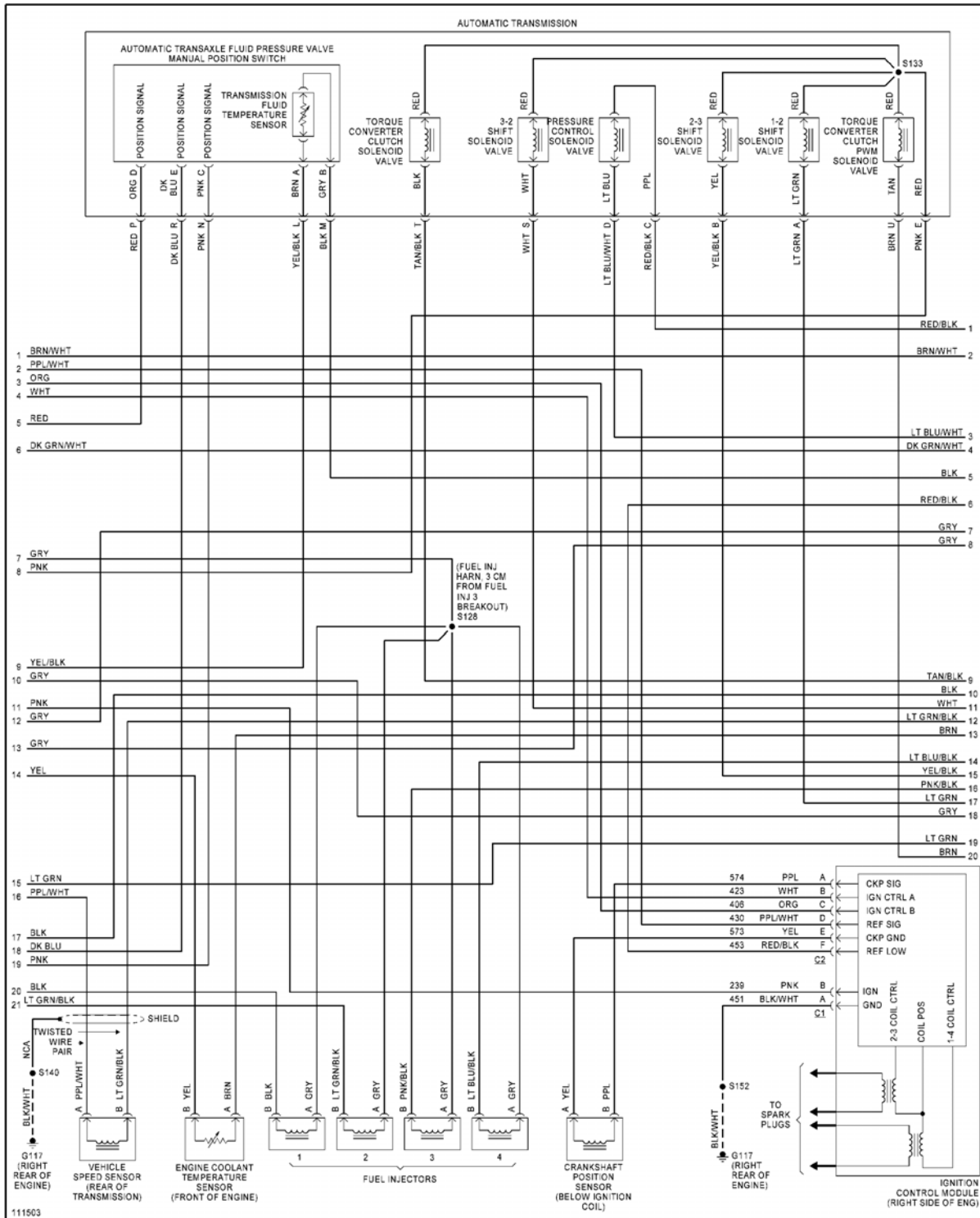

Fig. 17: 2.2L VIN 4, Engine Performance Circuits (2 of 3)

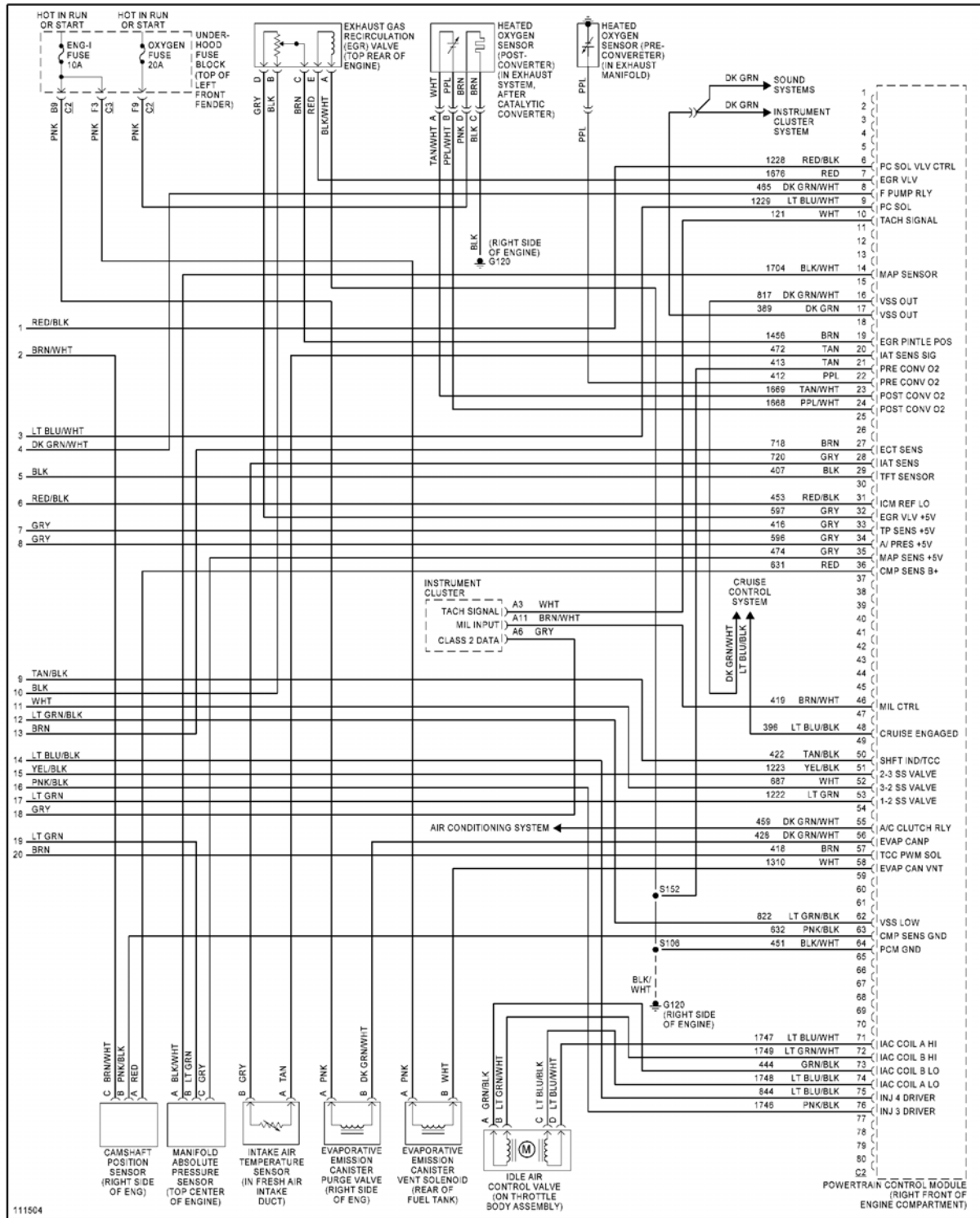

Fig. 18: 2.2L VIN 4, Engine Performance Circuits (3 of 3)

4.3L

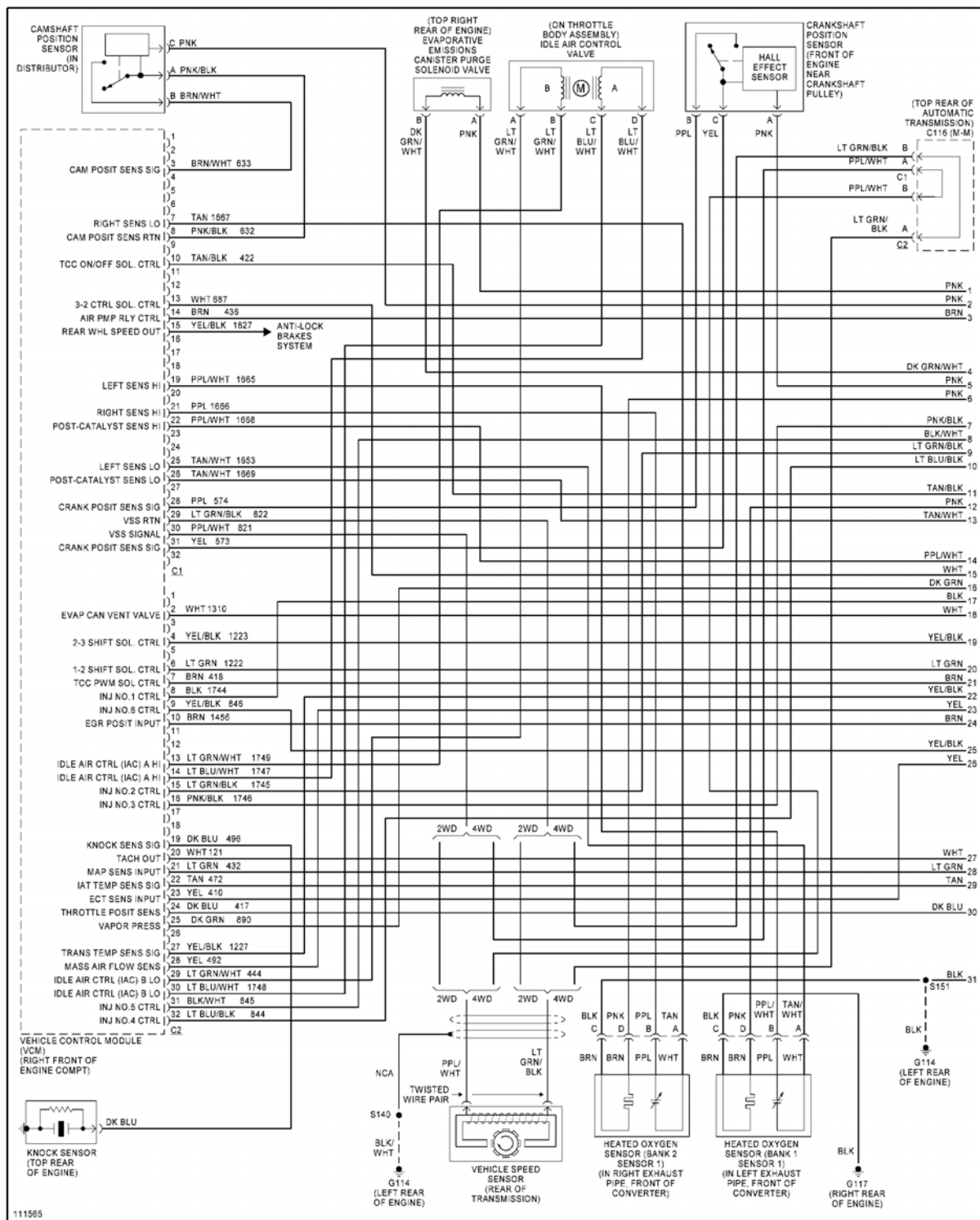

Fig. 19: 4.3L VIN W, Engine Performance Circuits (1 of 4)

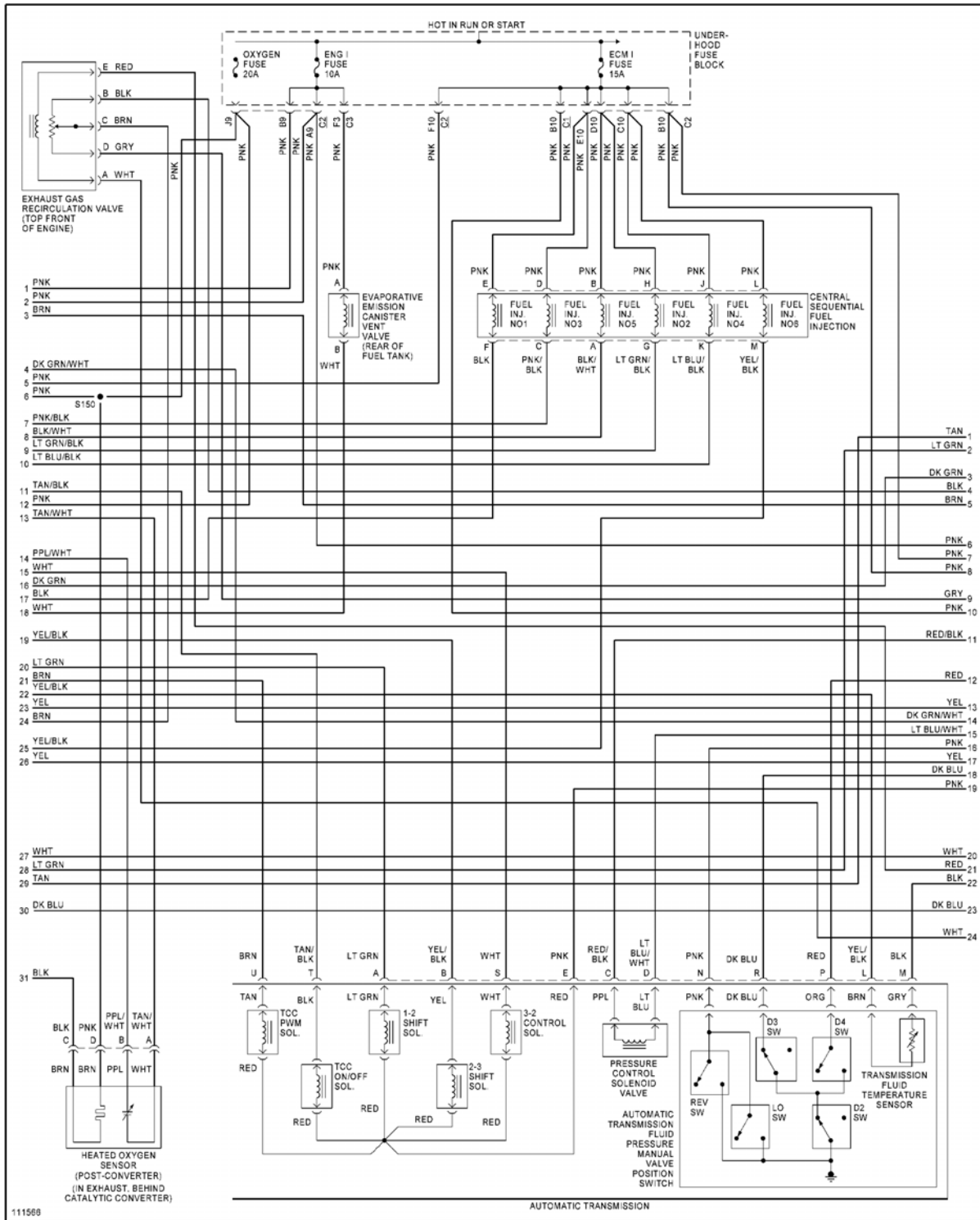

Fig. 20: 4.3L VIN W, Engine Performance Circuits (2 of 4)

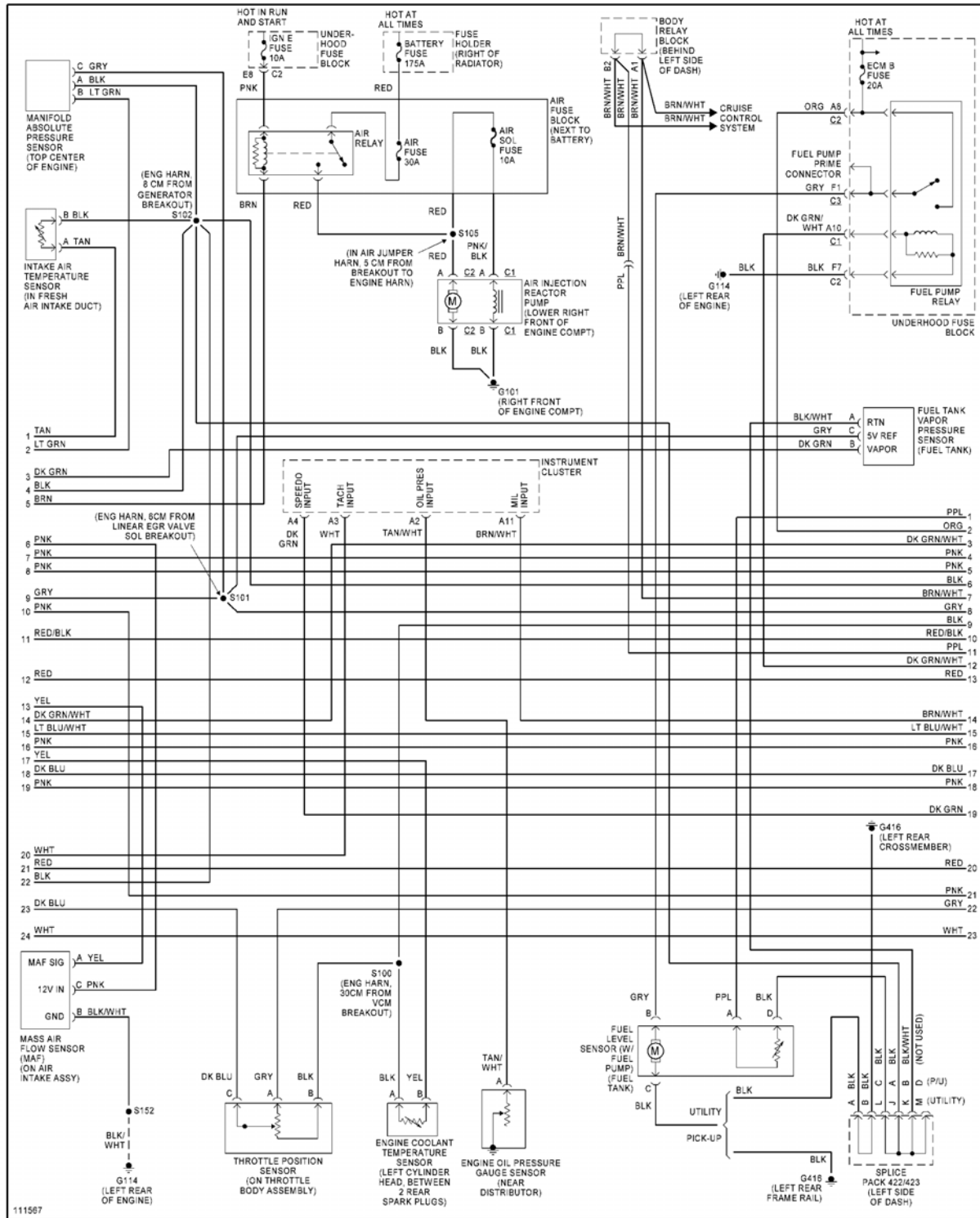

Fig. 21: 4.3L VIN W, Engine Performance Circuits (3 of 4)

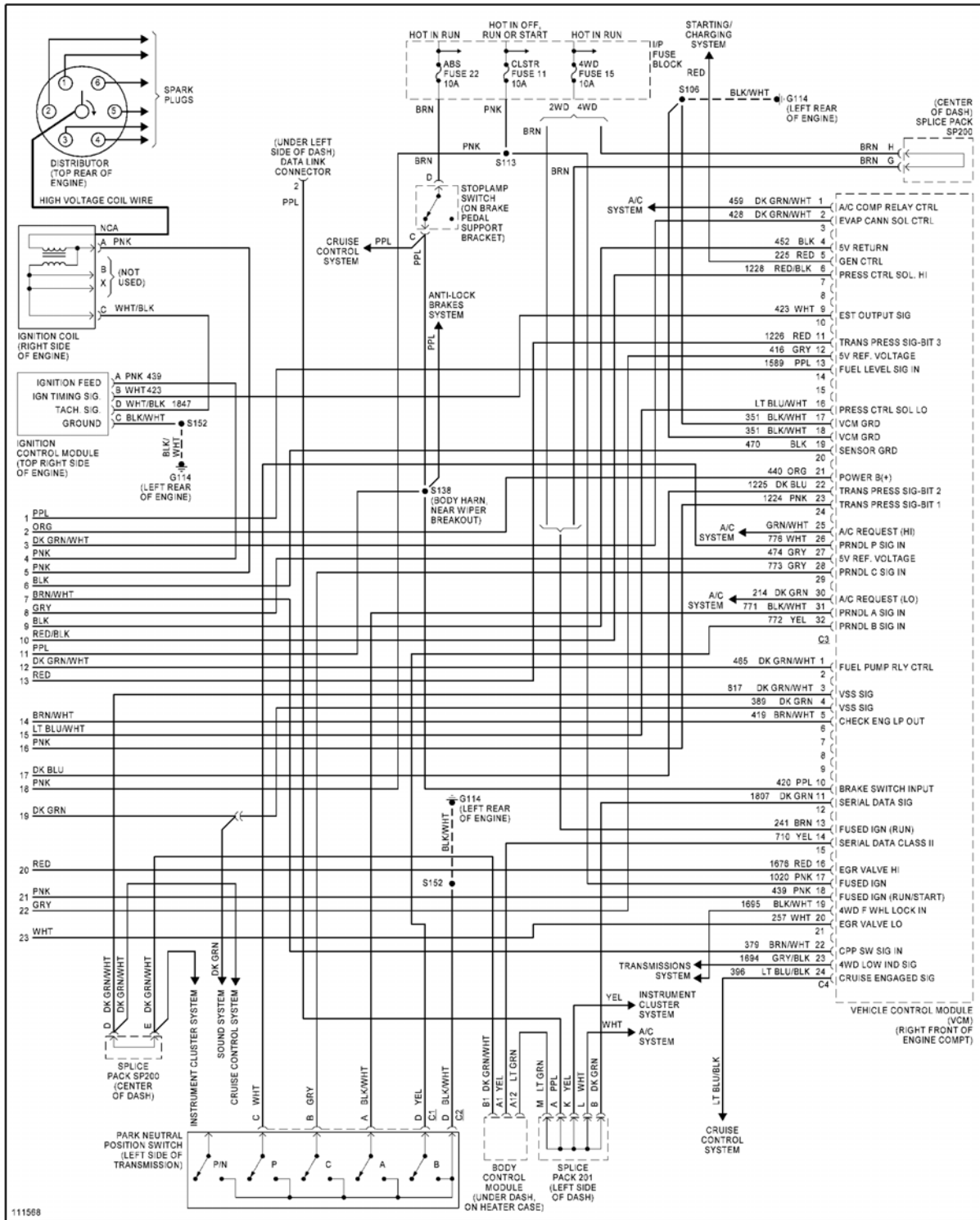

Fig. 22: 4.3L VIN W, Engine Performance Circuits (4 of 4)

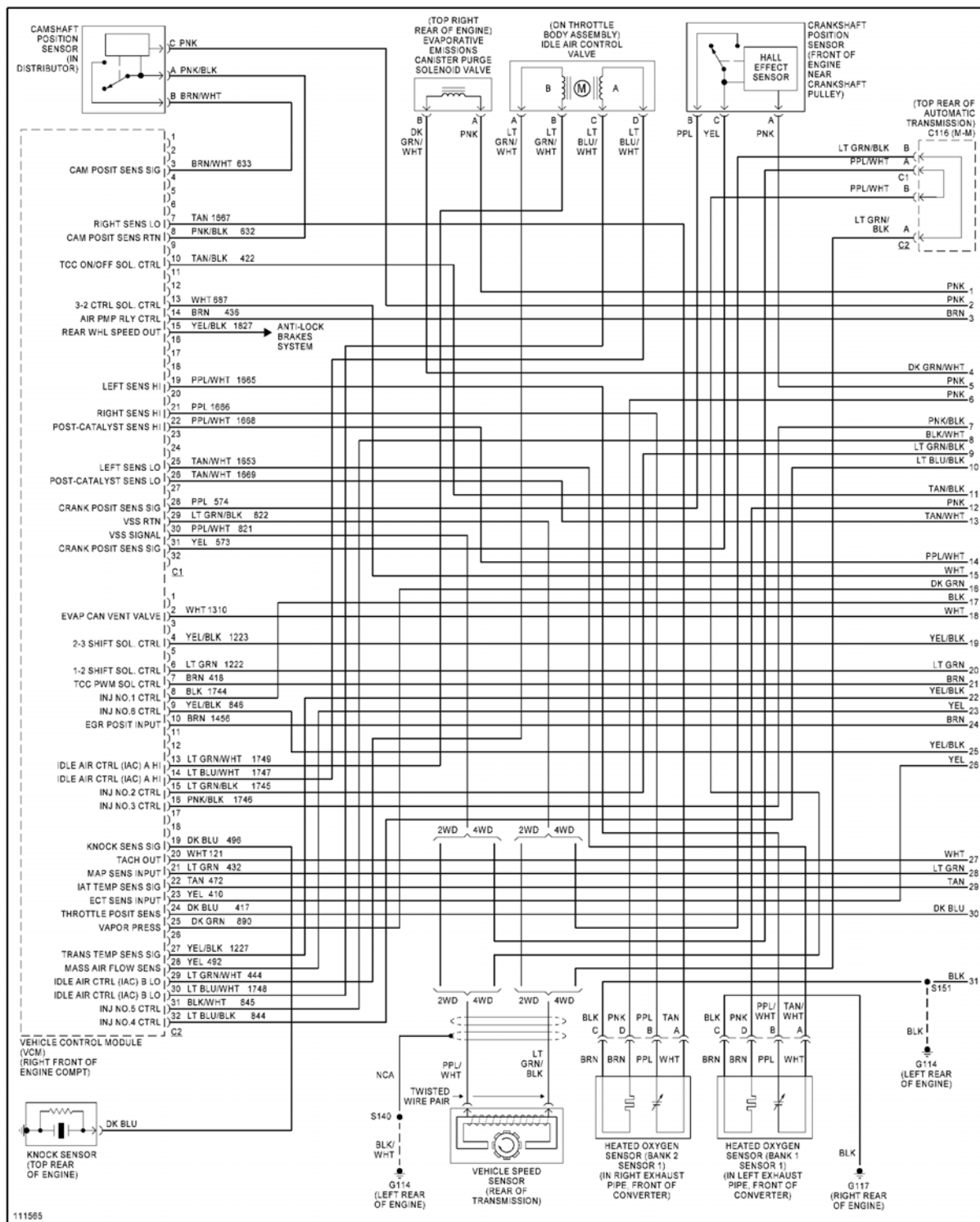

Fig. 23: 4.3L VIN X, Engine Performance Circuits (1 of 4)

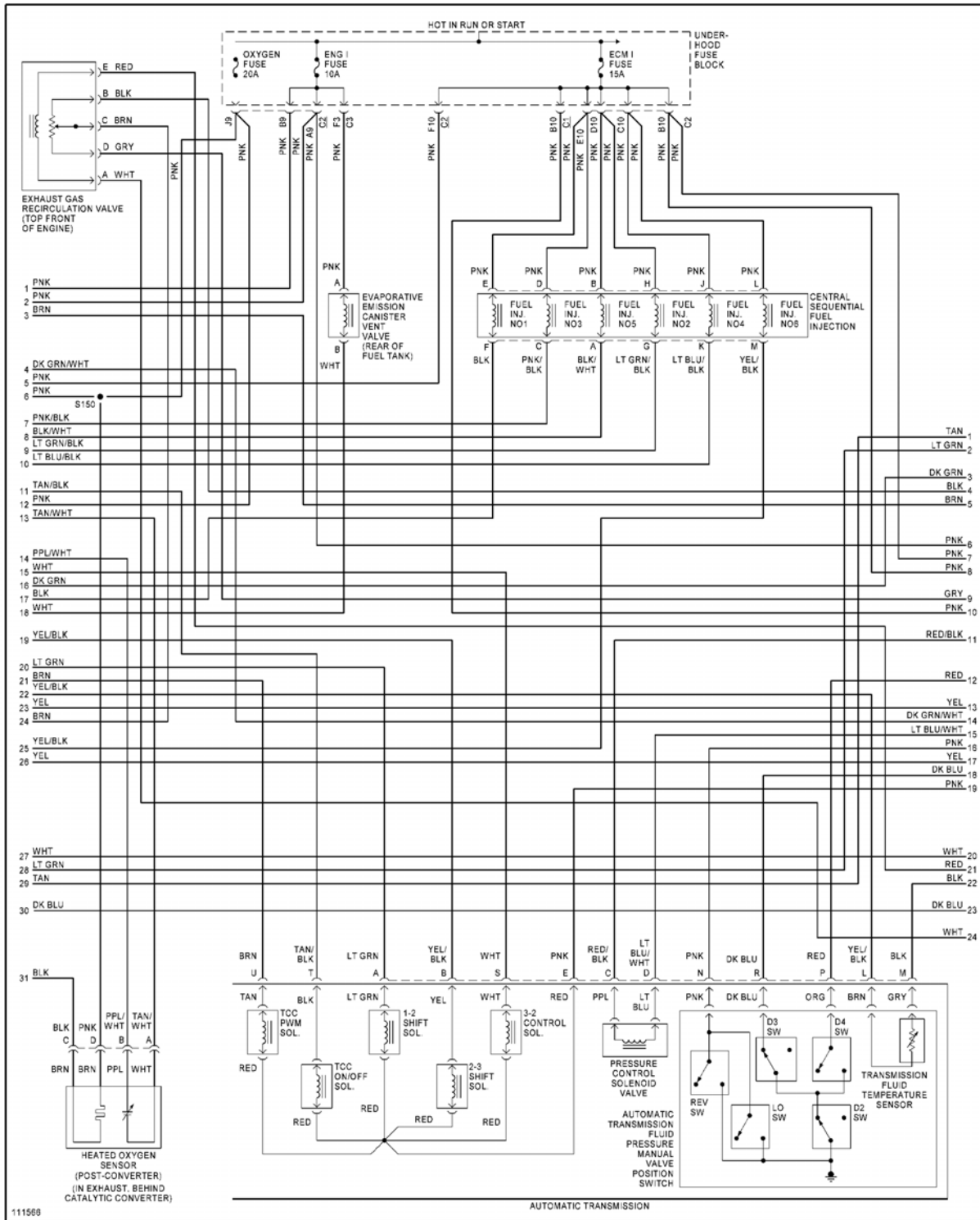

Fig. 24: 4.3L VIN X, Engine Performance Circuits (2 of 4)

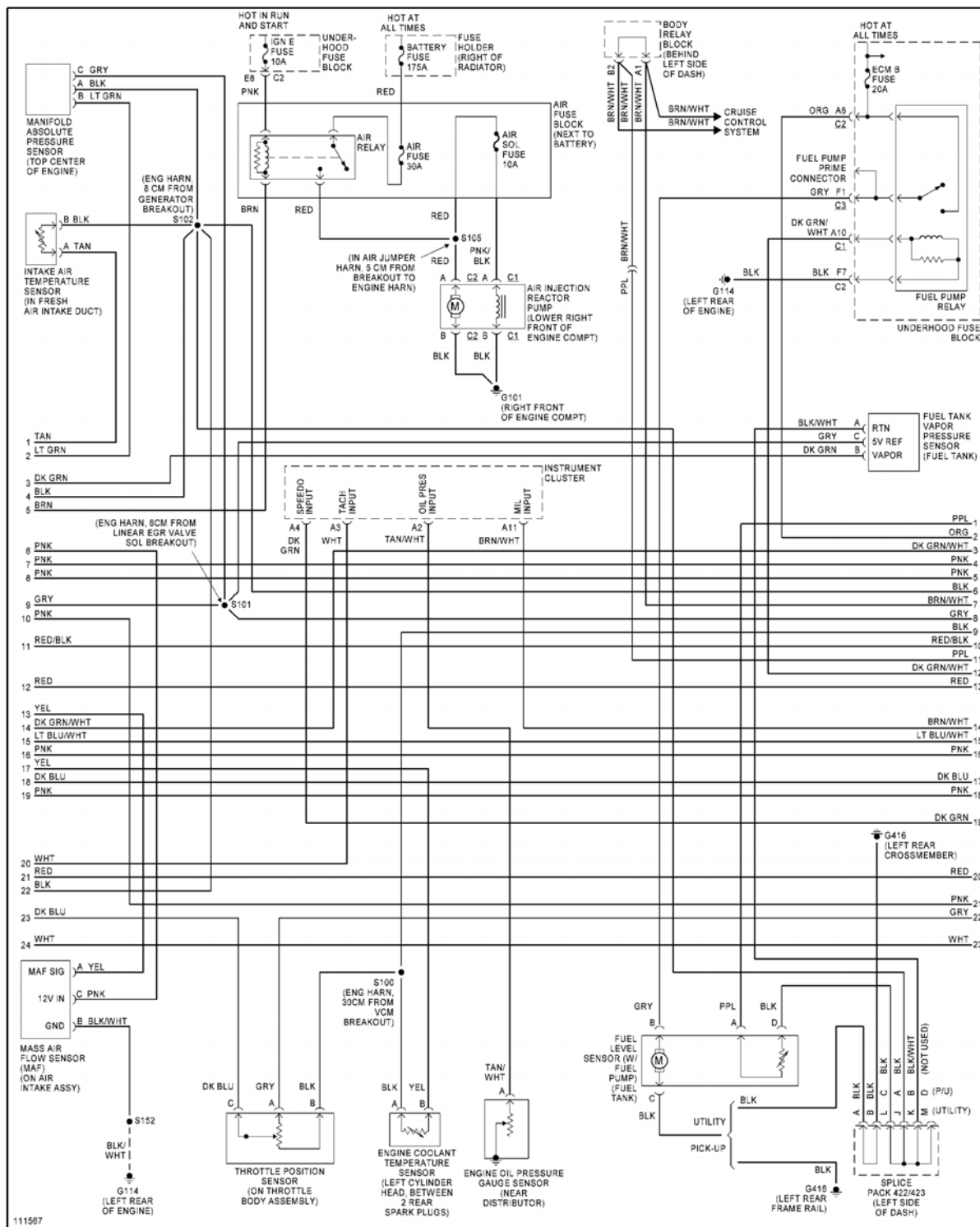

Fig. 25: 4.3L VIN X, Engine Performance Circuits (3 of 4)

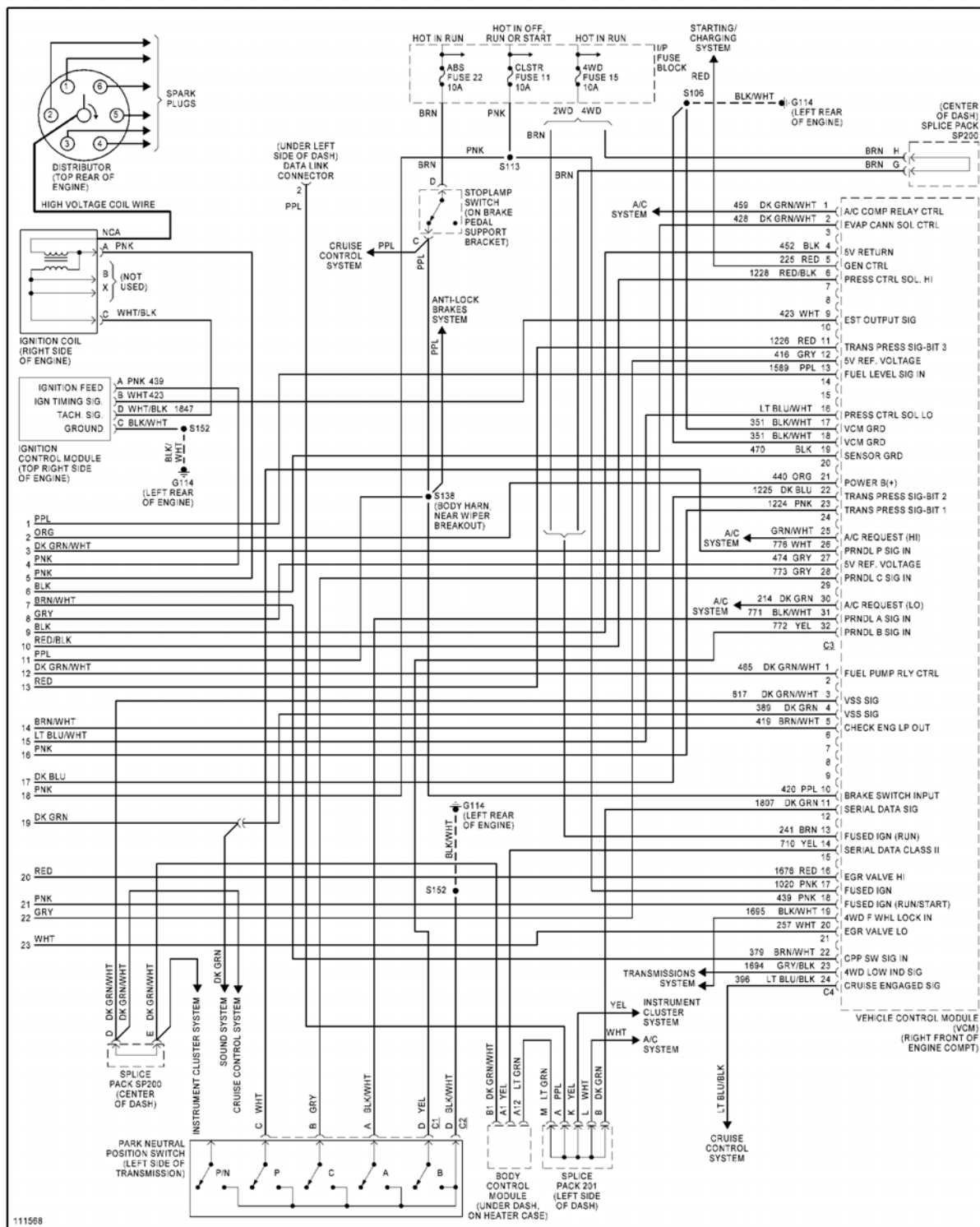

Fig. 26: 4.3L VIN X, Engine Performance Circuits (4 of 4)

EXTERIOR LIGHTS 

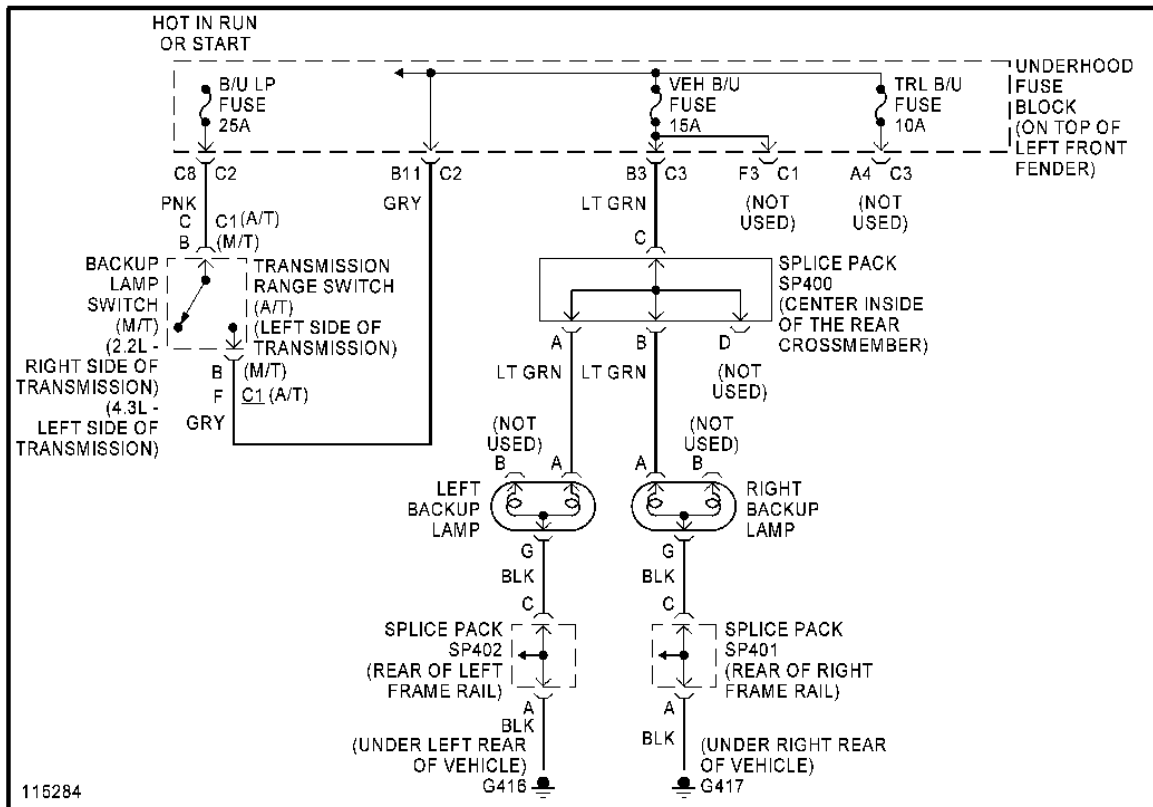

Fig. 27: Back-up Lamps Circuit

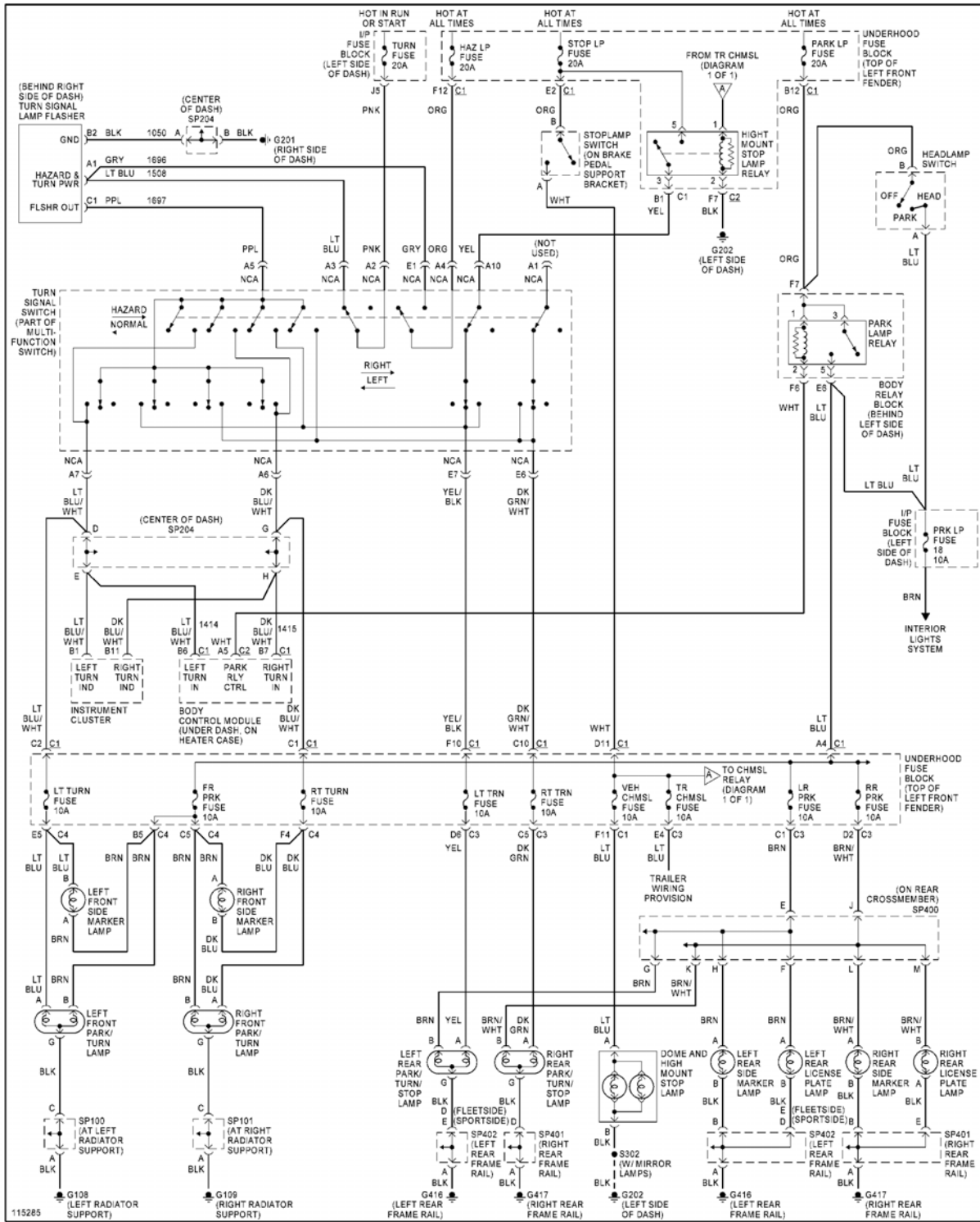

Fig. 28: Exterior Lamps Circuit

GROUND DISTRIBUTION

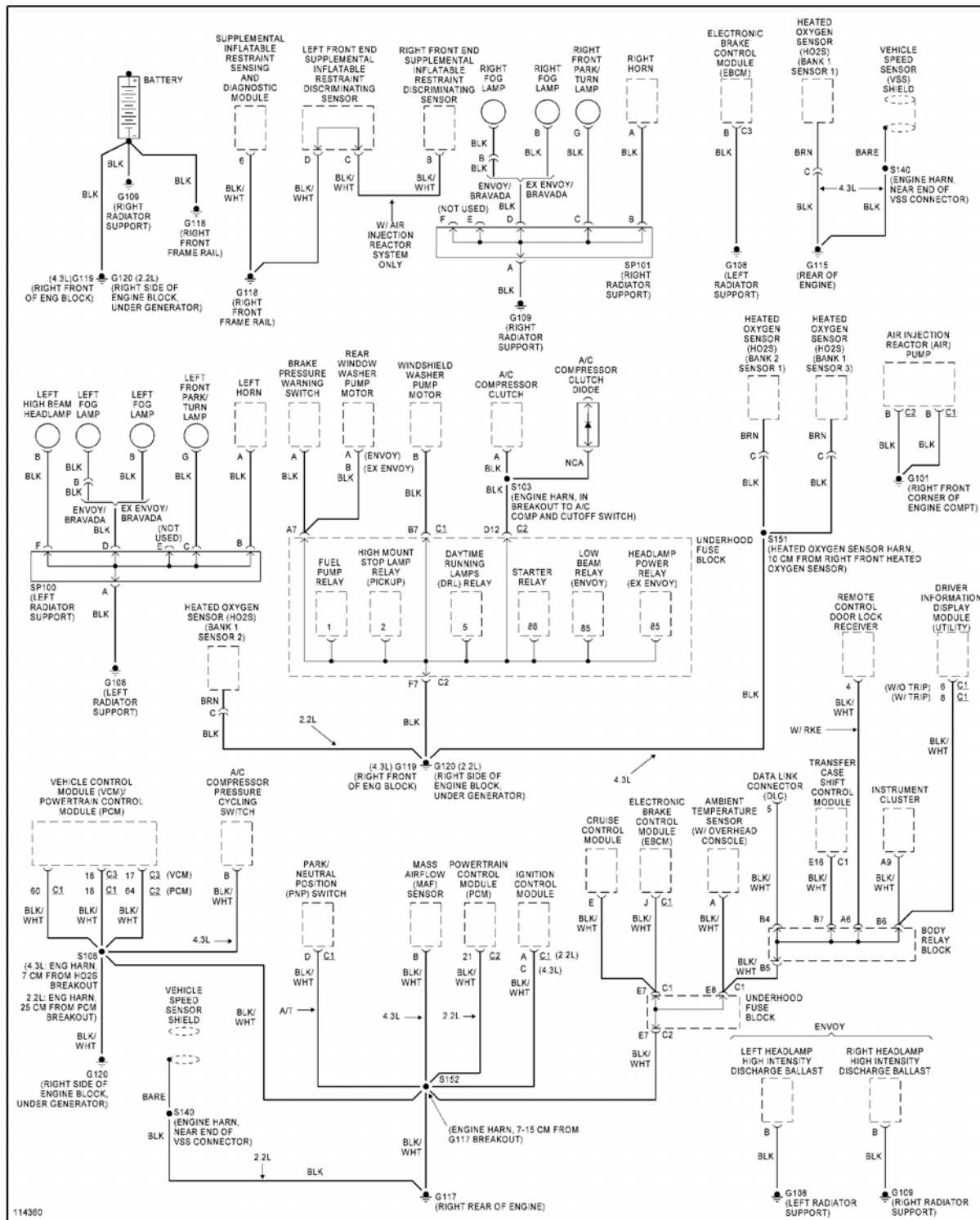

Fig. 29: Ground Distribution Circuit (1 of 3)

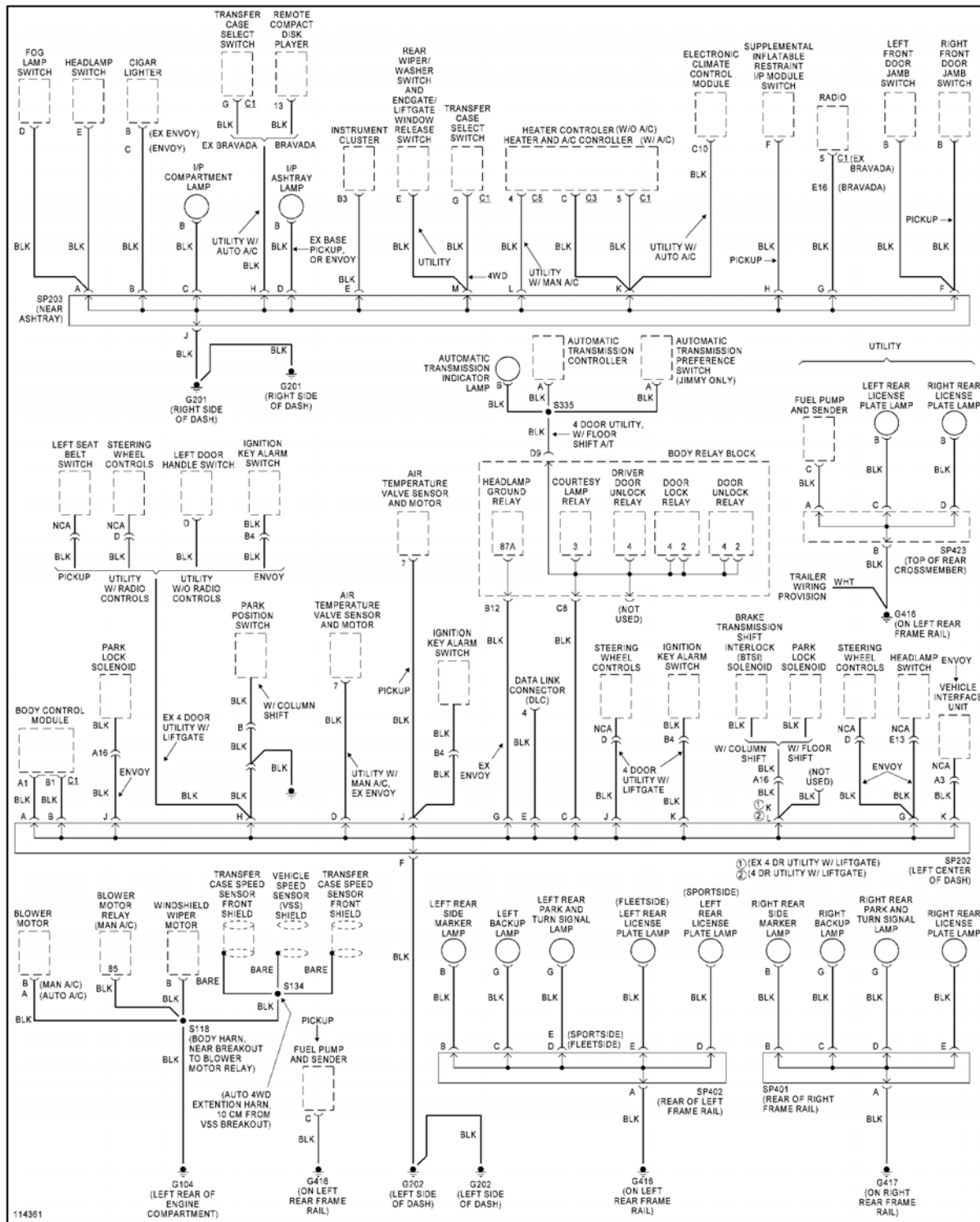

Fig. 30: Ground Distribution Circuit (2 of 3)

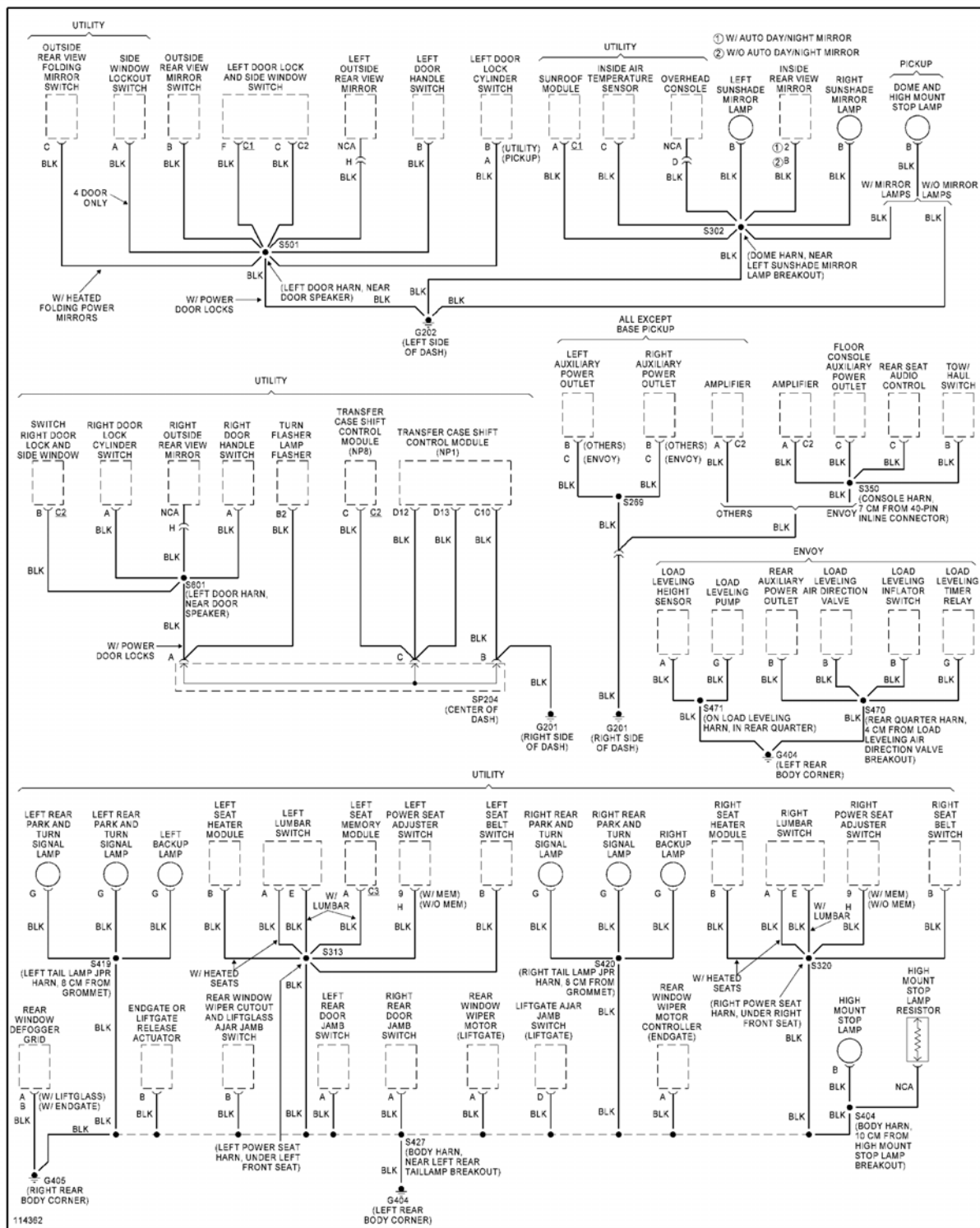

Fig. 31: Ground Distribution Circuit (3 of 3)

HEADLIGHTS 

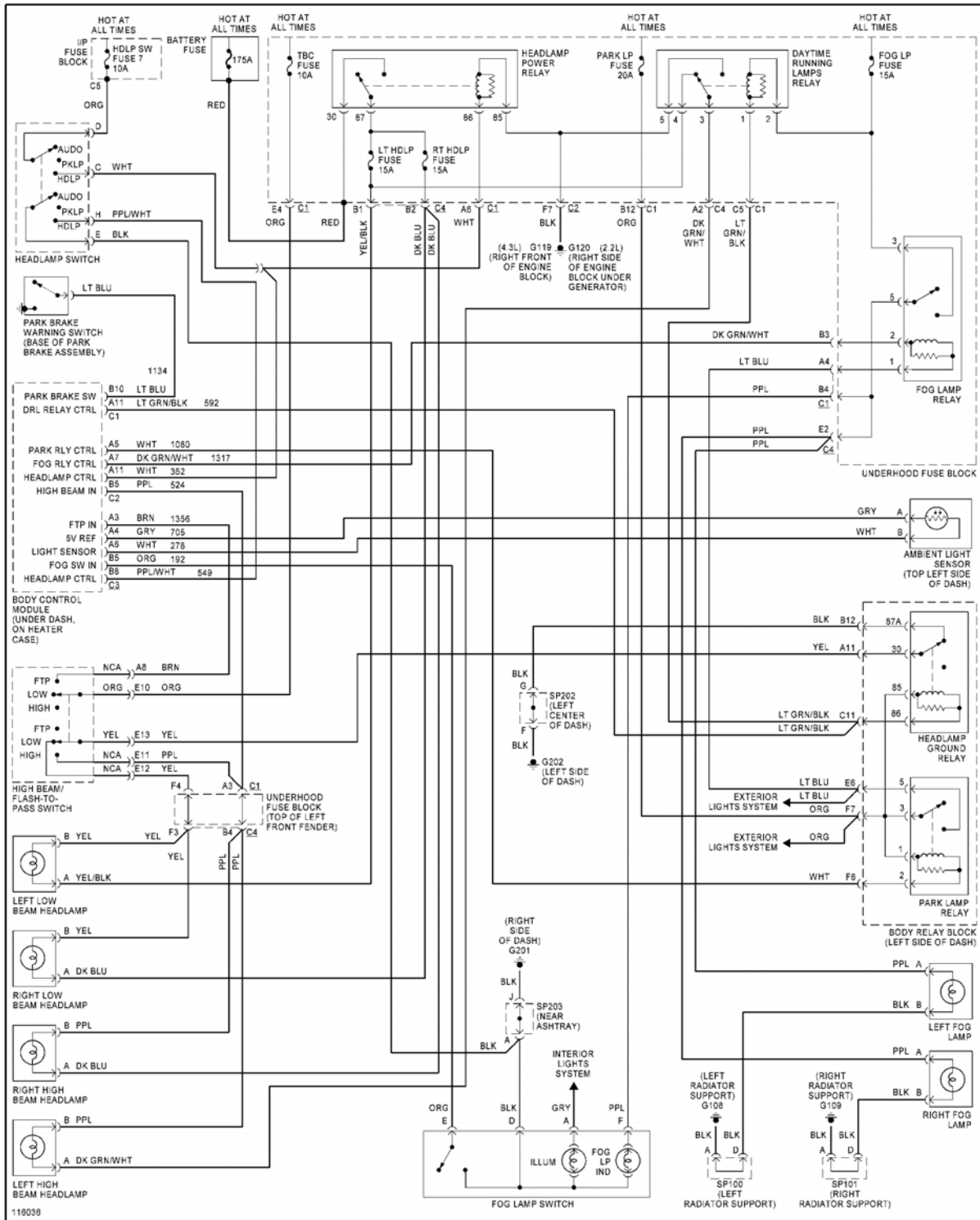

Fig. 32: Headlight Circuit

HORN

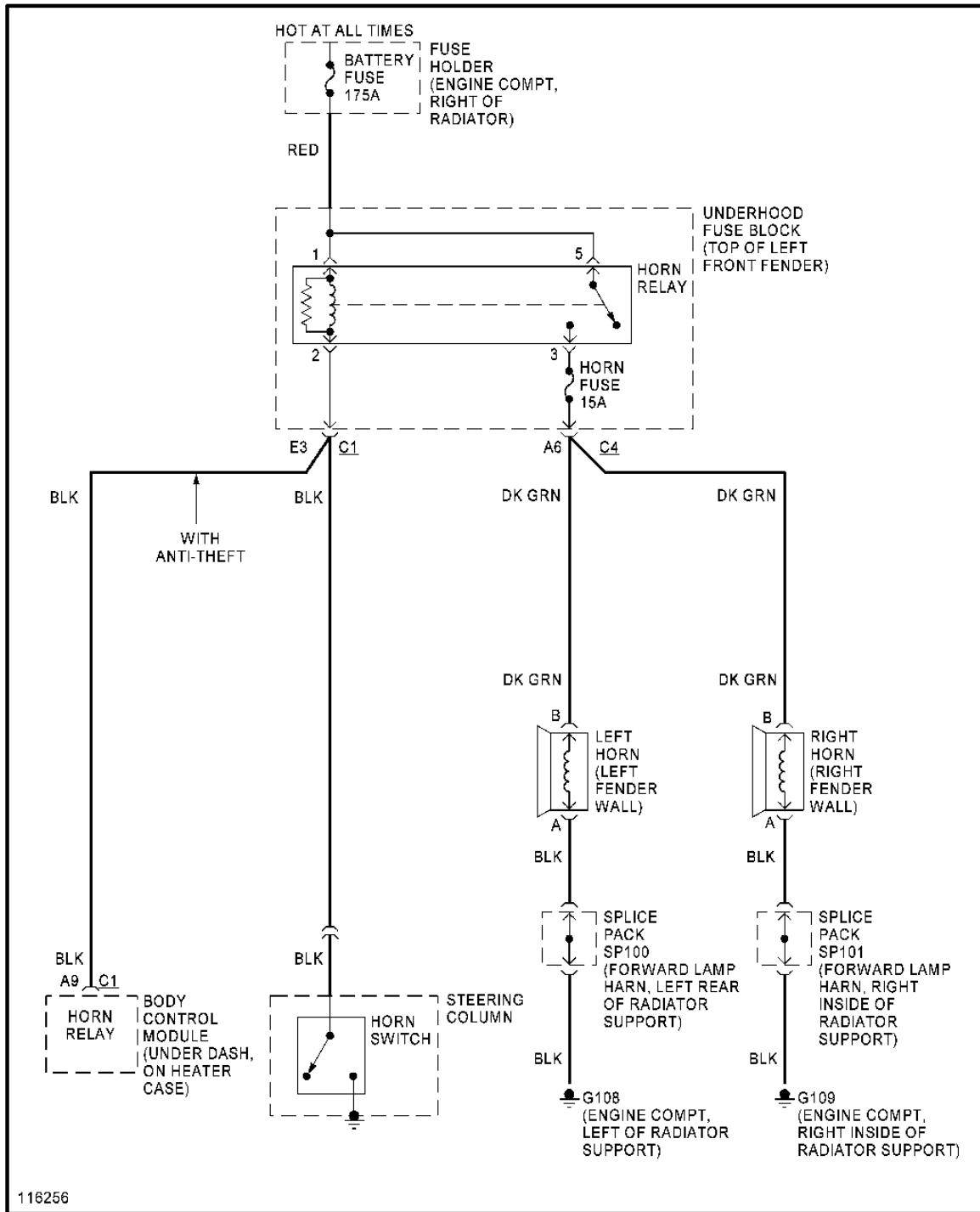

Fig. 33: Horn Circuit

INSTRUMENT CLUSTER 

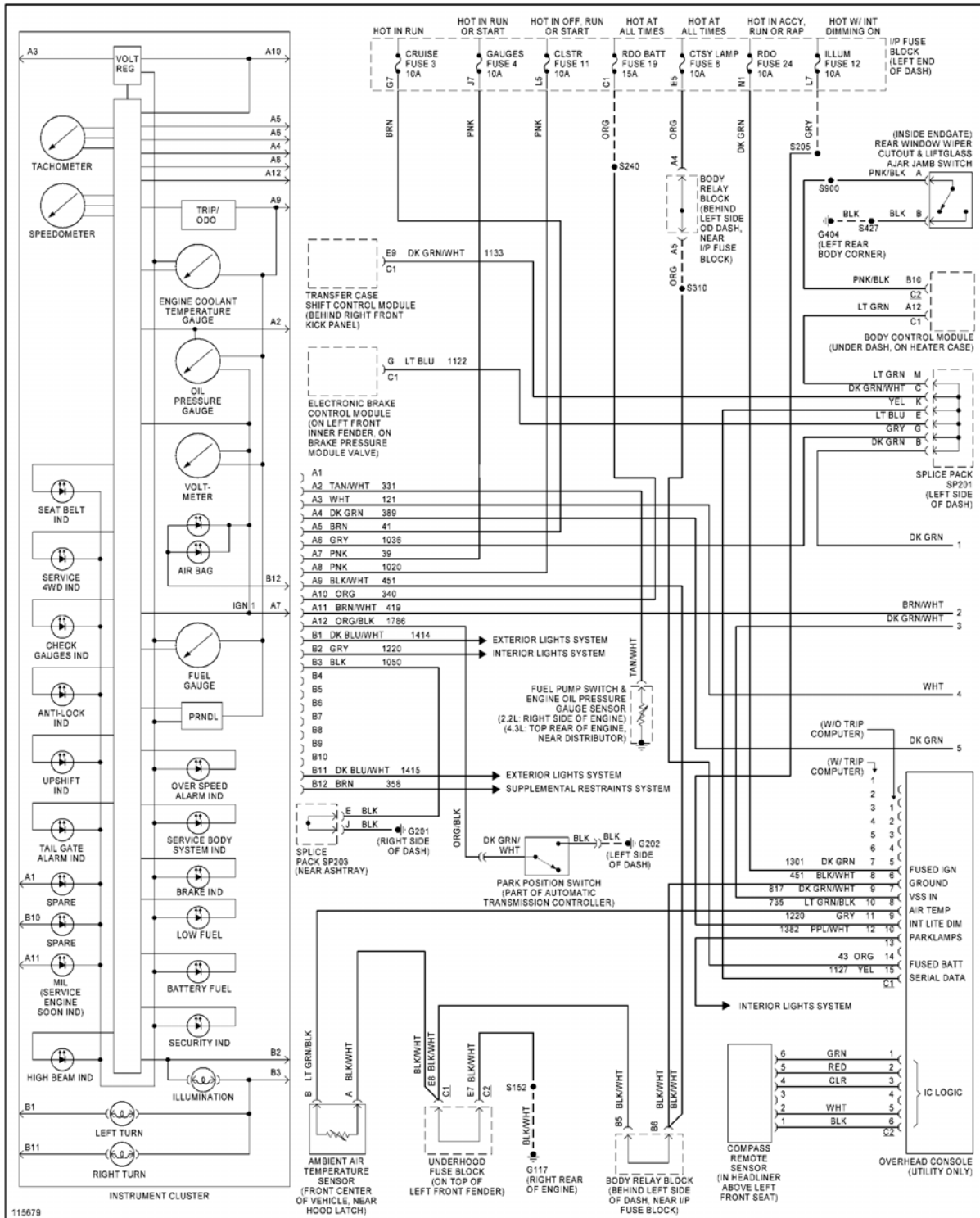

Fig. 34: Instrument Cluster Circuit (1 of 2)

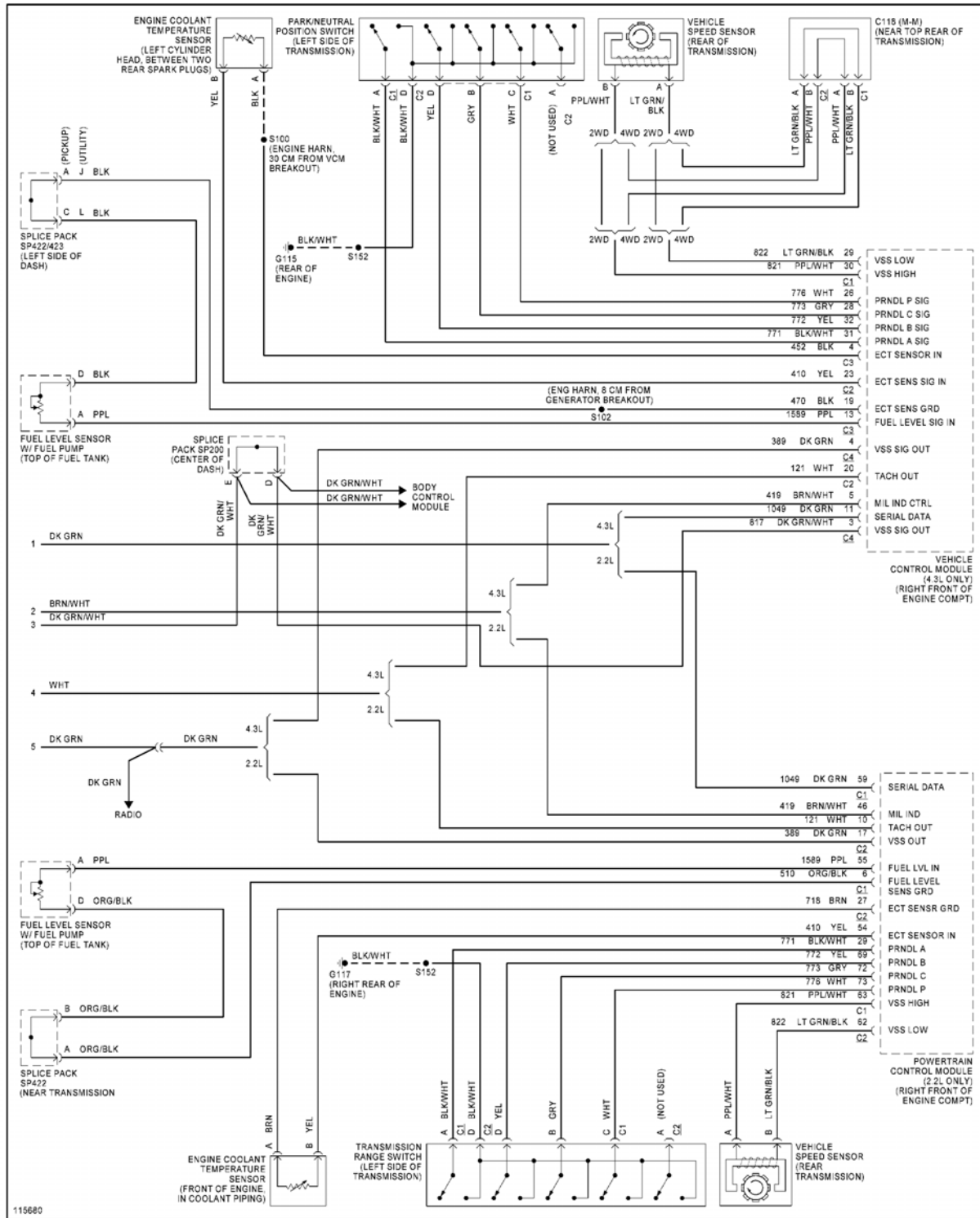

Fig. 35: Instrument Cluster Circuit (2 of 2)

INTERIOR LIGHTS 

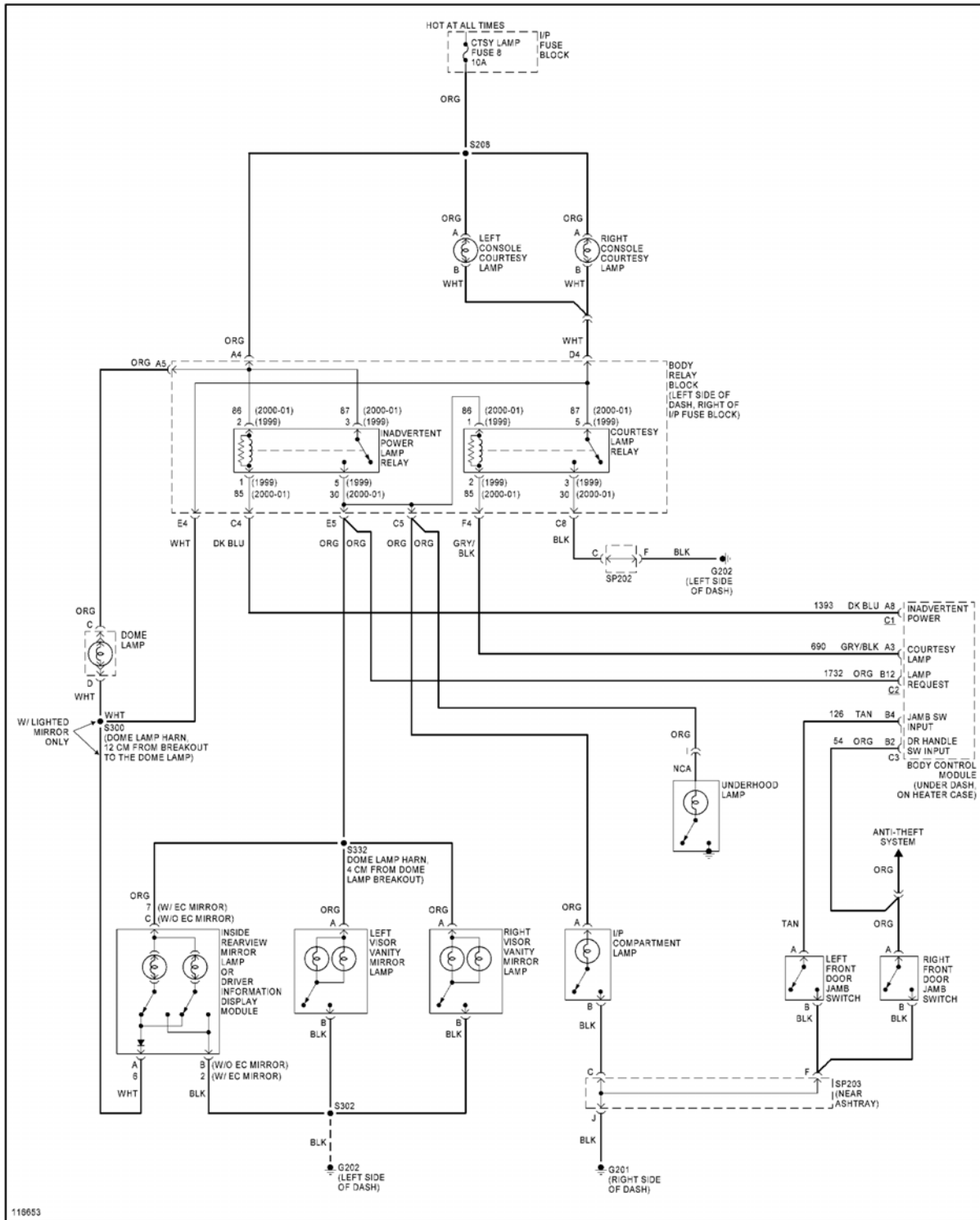

Fig. 36: Courtesy Lamps Circuit

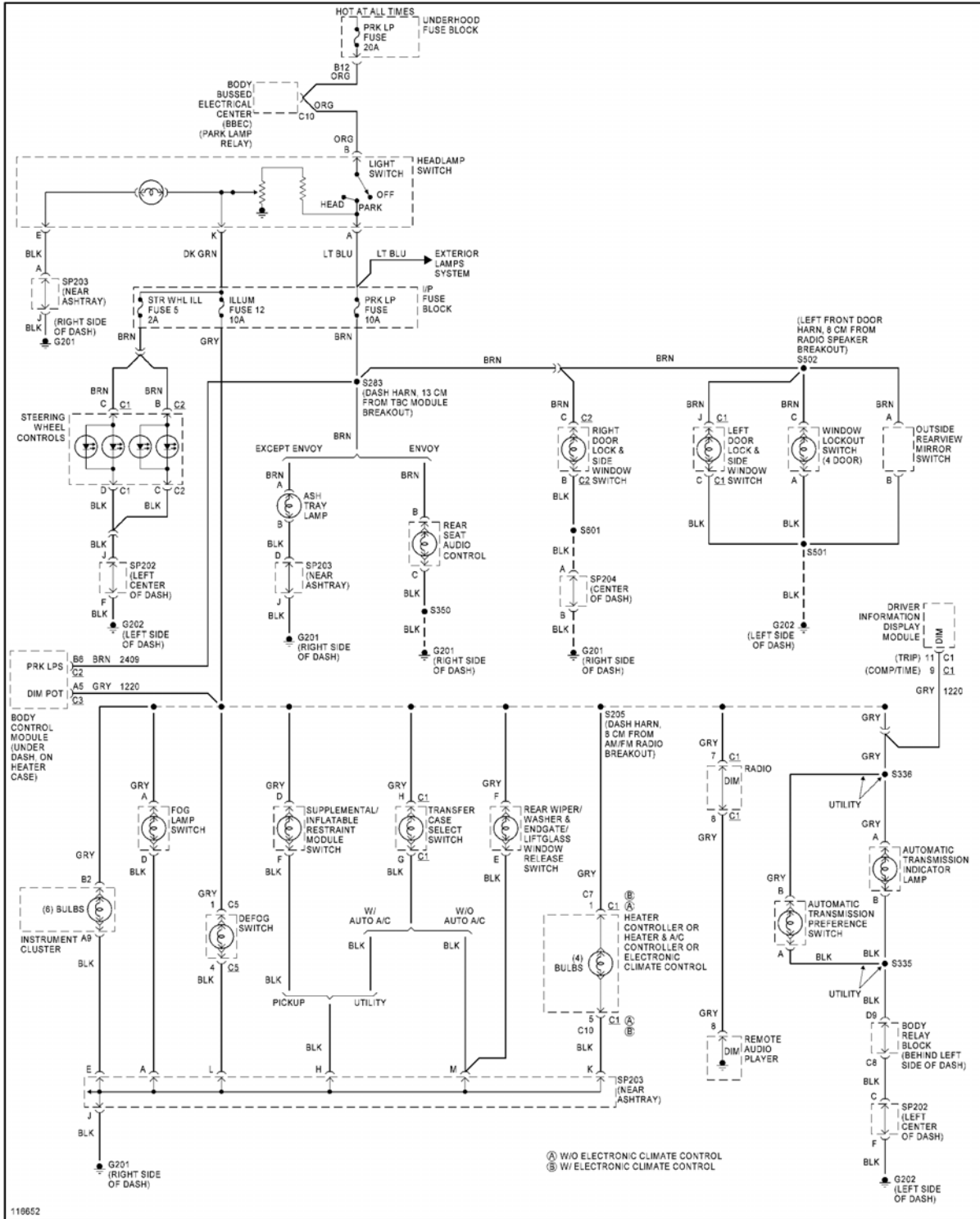

Fig. 37: Instrument Illumination Circuit

POWER DISTRIBUTION

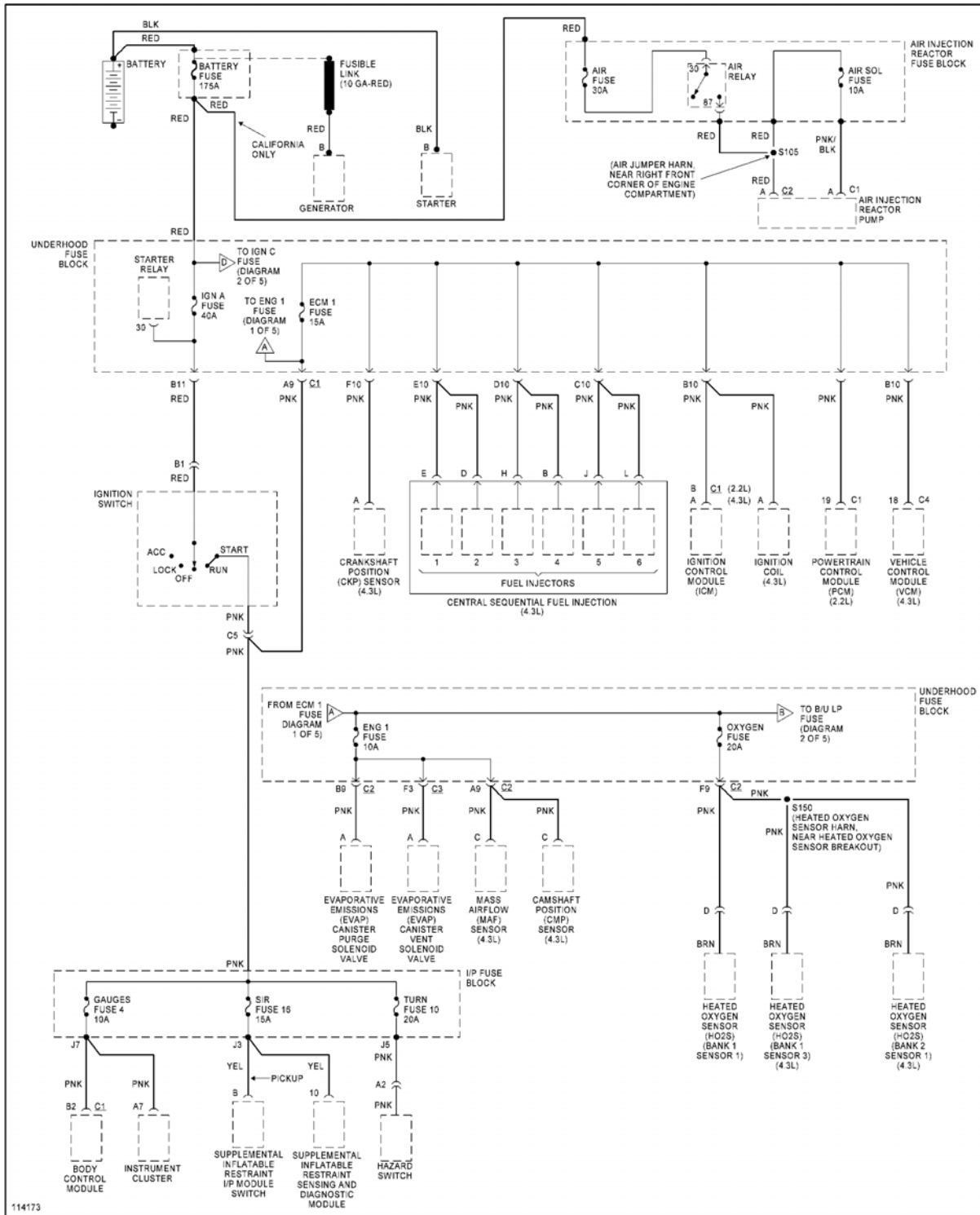

Fig. 38: Power Distribution Circuit (1 of 5)

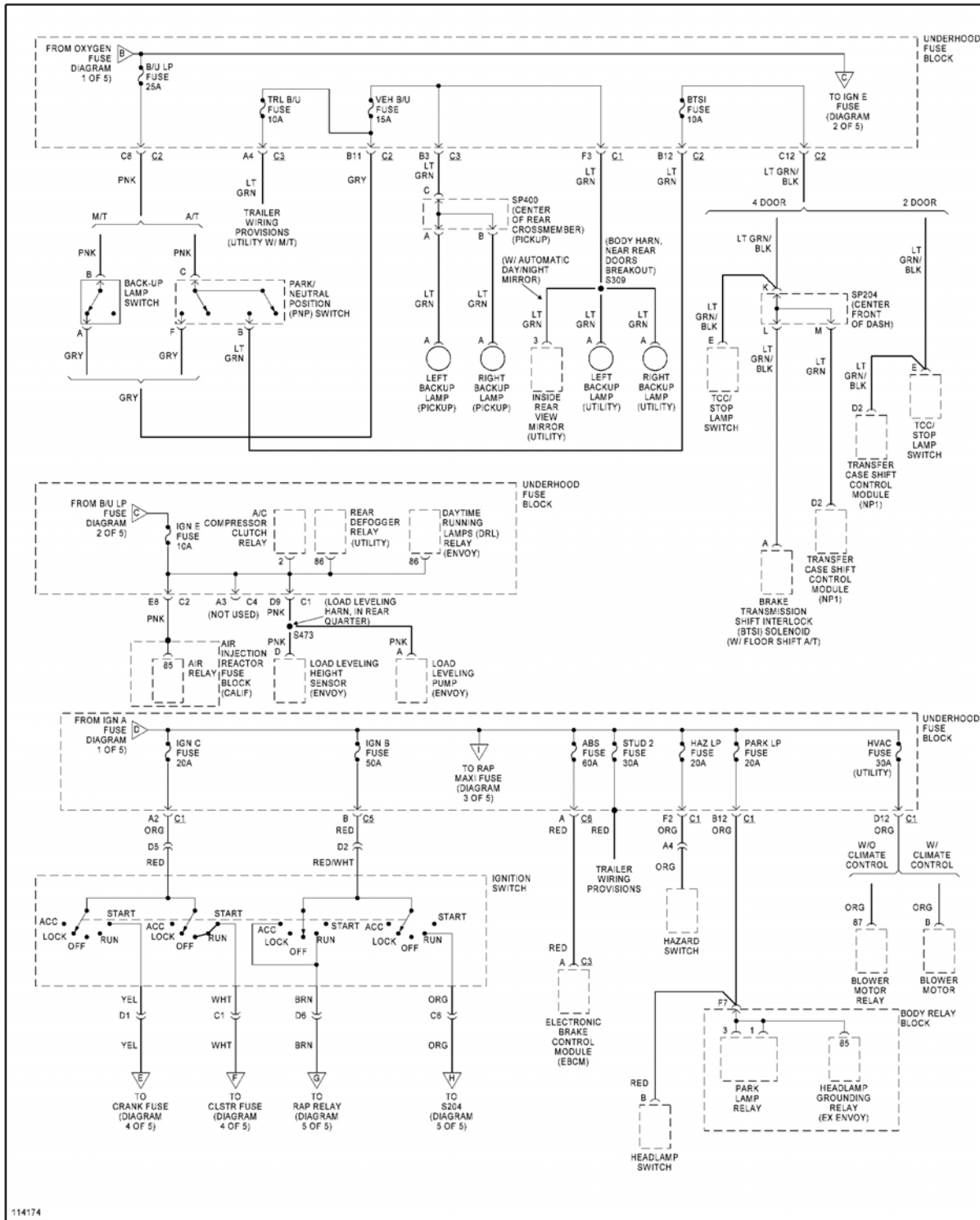

Fig. 39: Power Distribution Circuit (2 of 5)

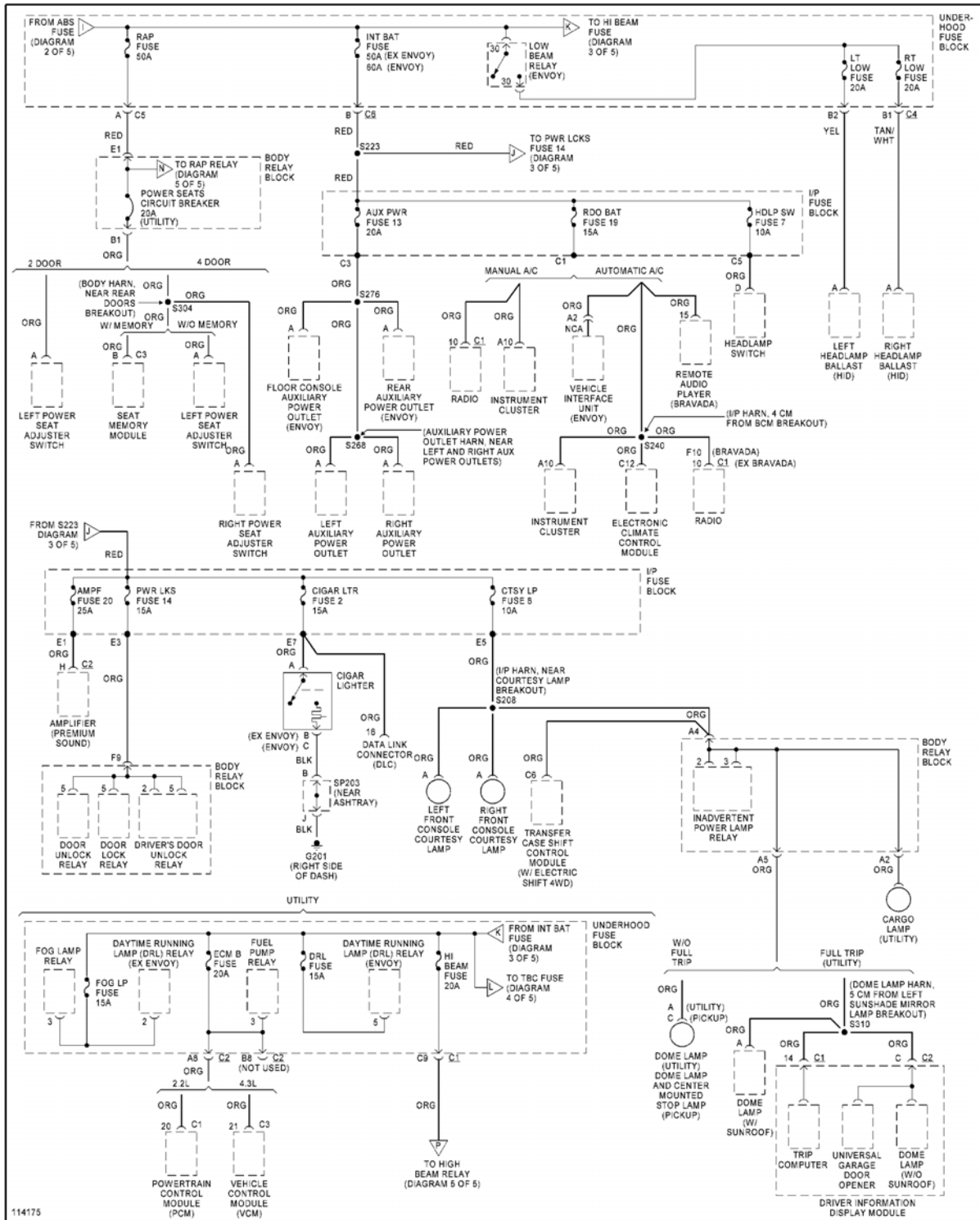

Fig. 40: Power Distribution Circuit (3 of 5)

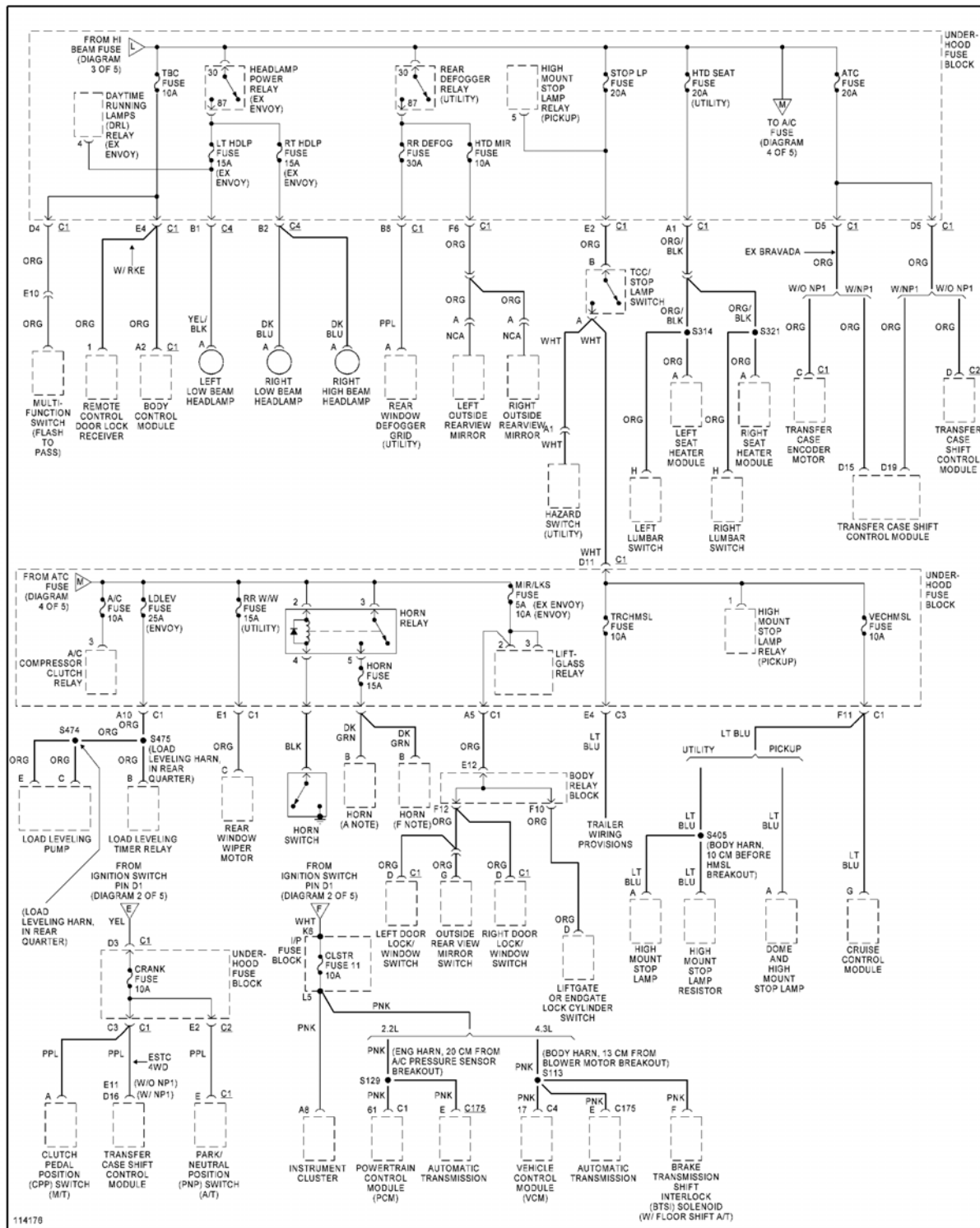

Fig. 41: Power Distribution Circuit (4 of 5)

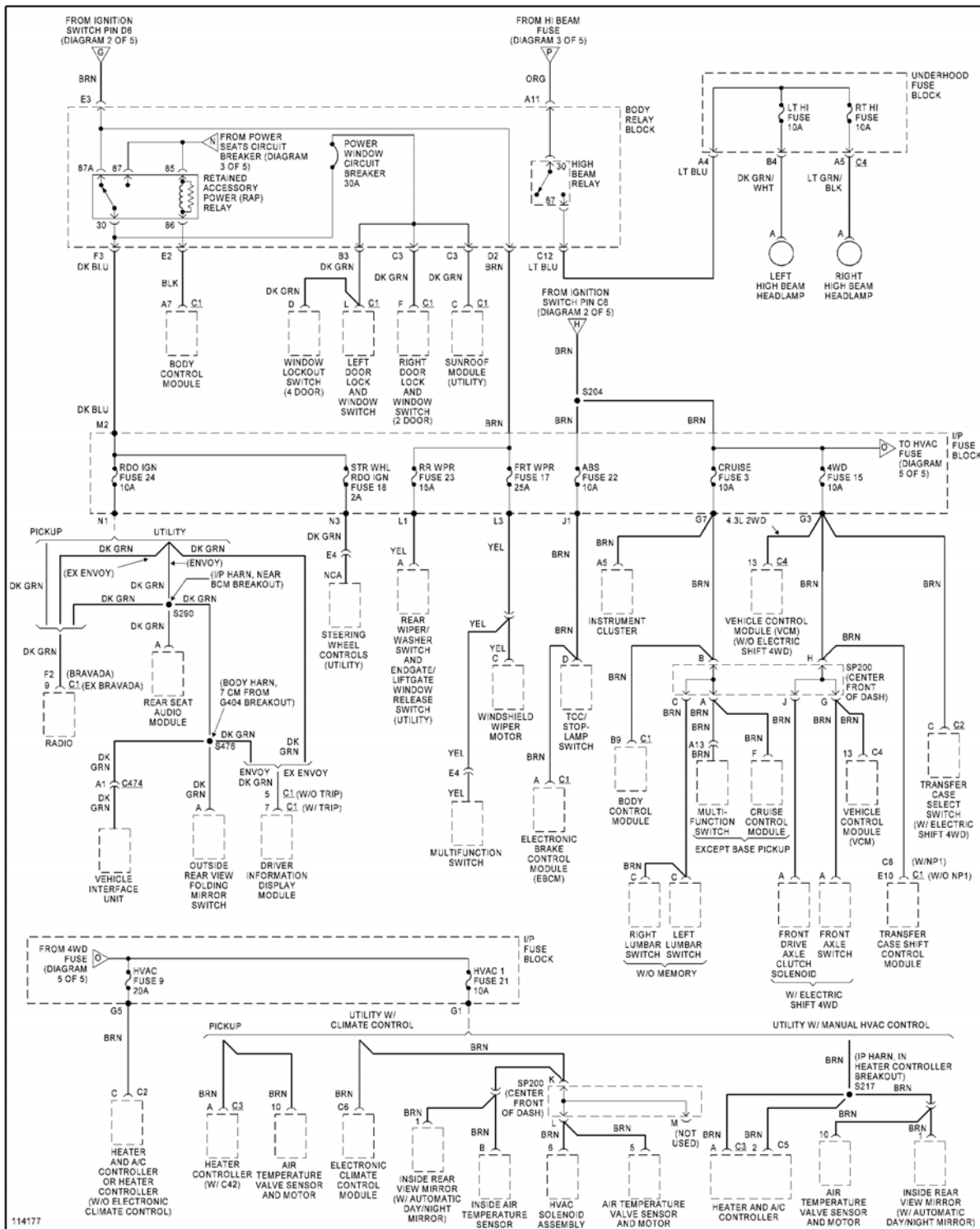

Fig. 42: Power Distribution Circuit (5 of 5)

POWER DOOR LOCKS 

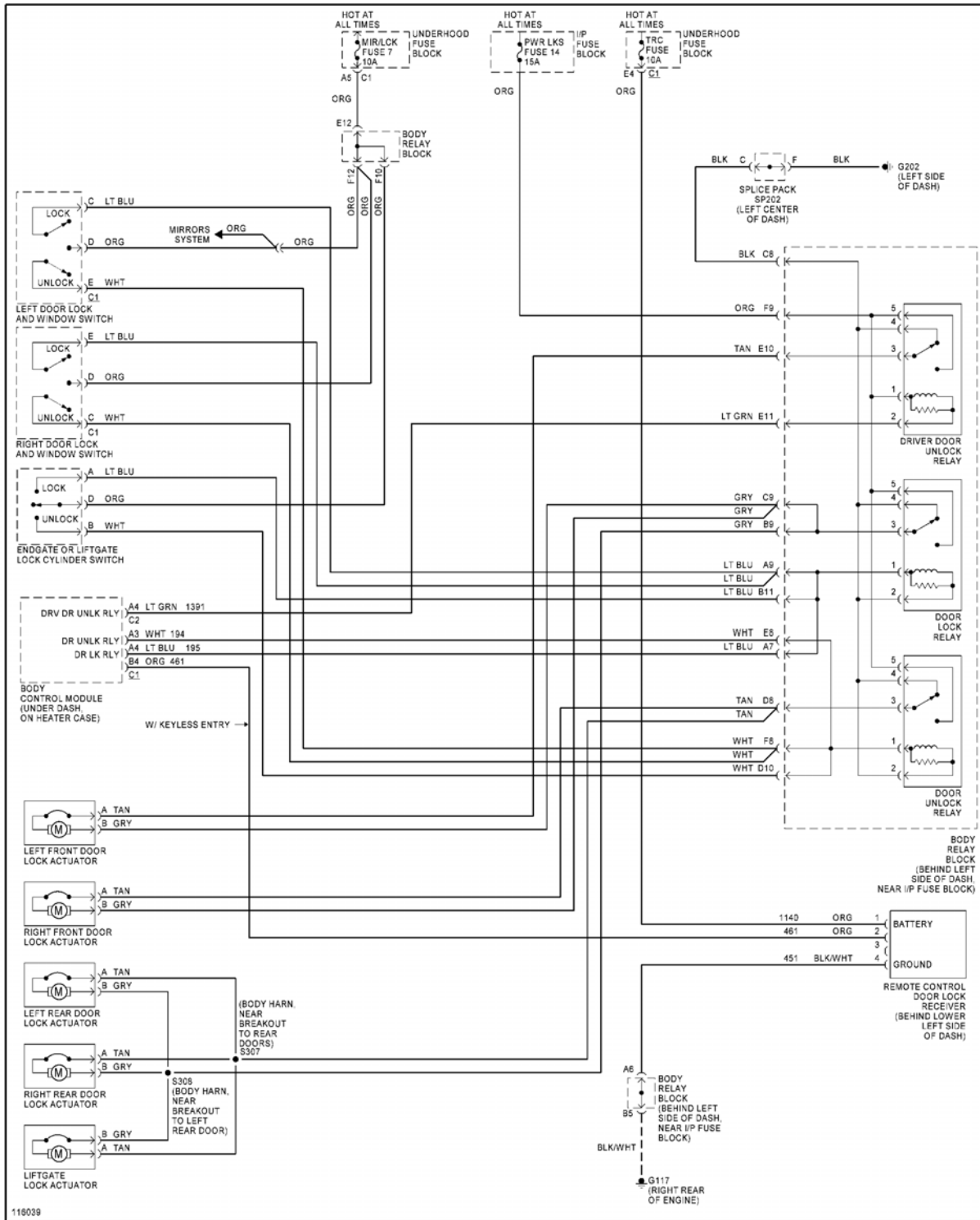

Fig. 43: Power Door Lock Circuit

POWER MIRRORS 

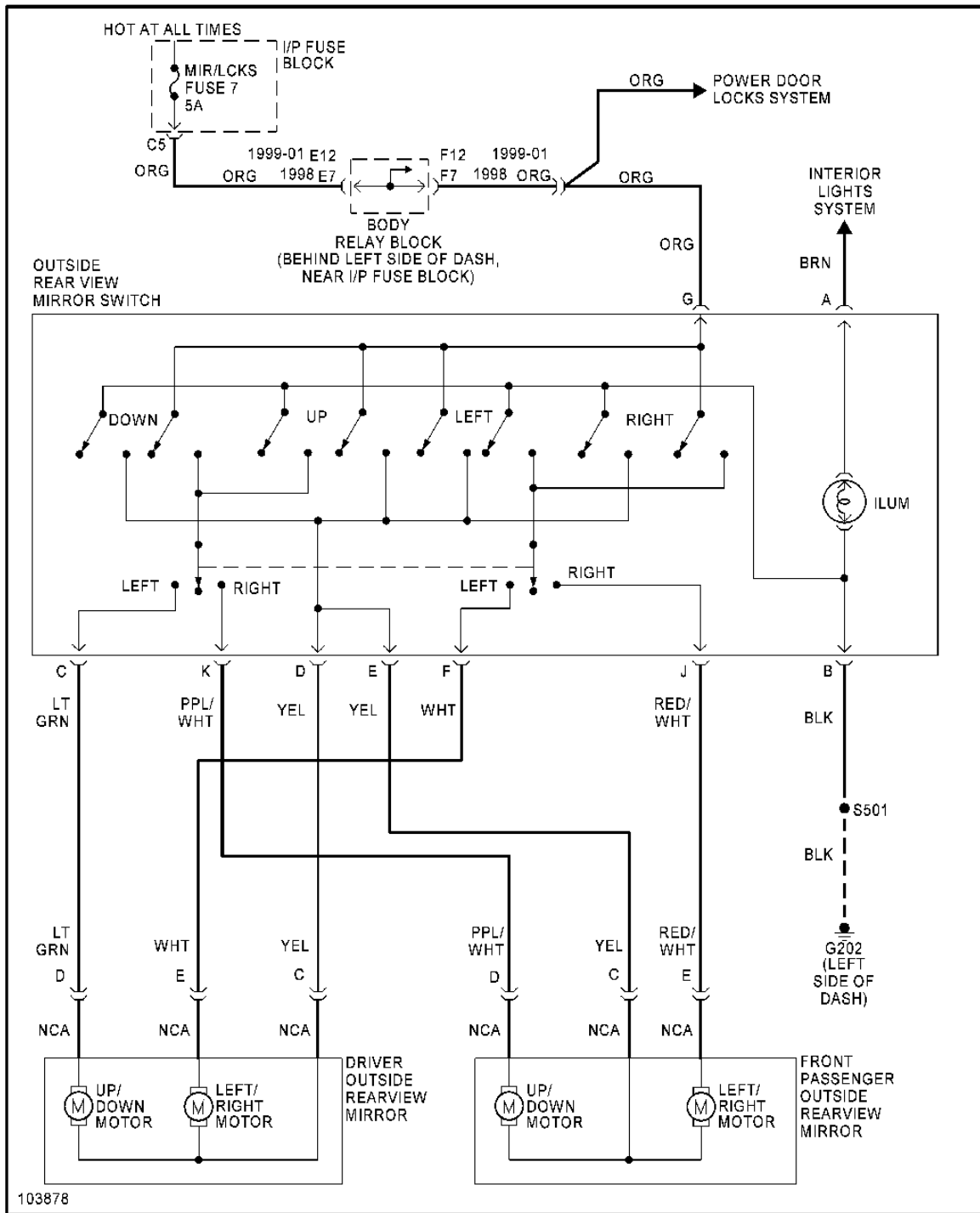

Fig. 44: Power Mirrors Circuit

POWER WINDOWS 

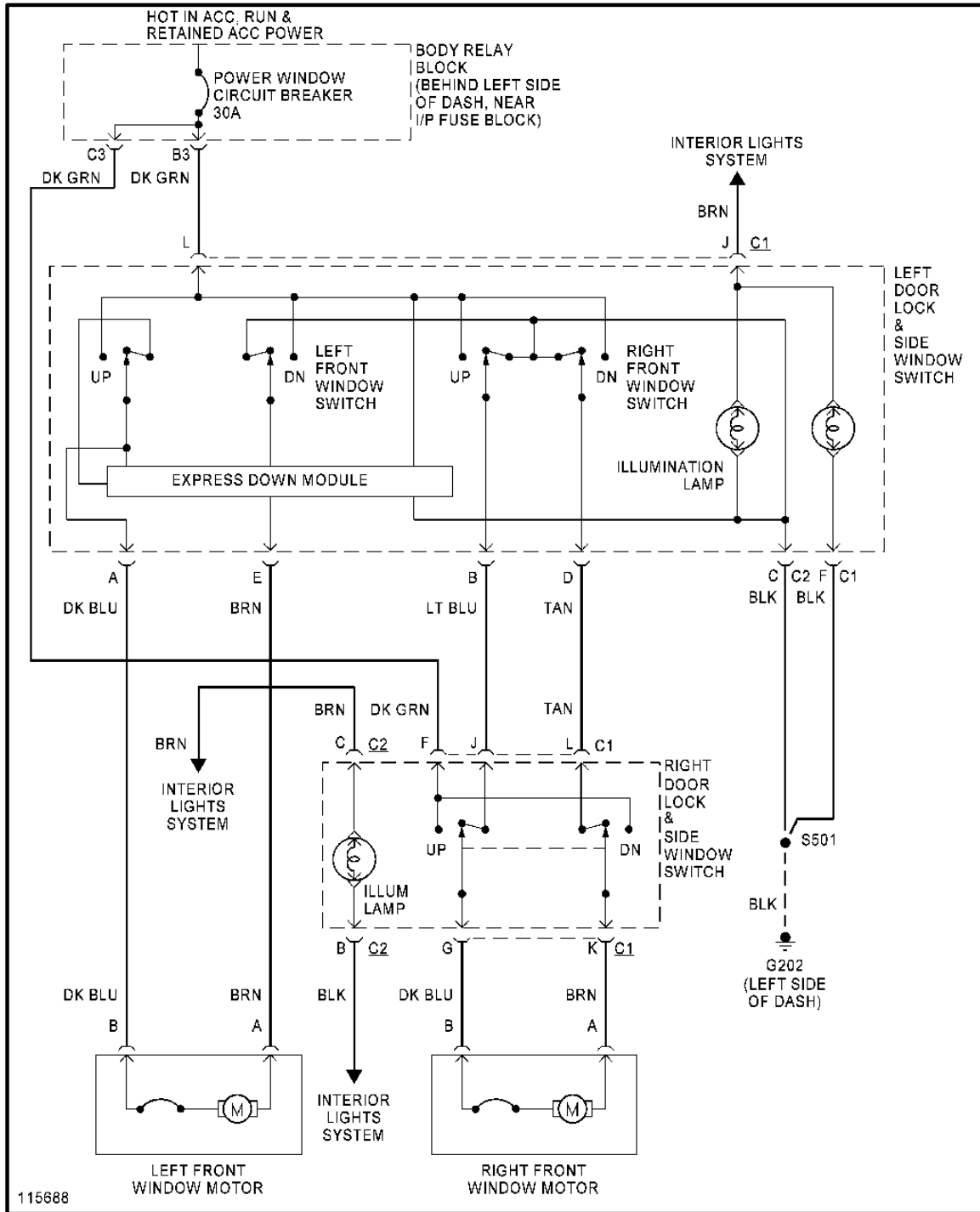

Fig. 45: Power Window Circuit, 2 Door

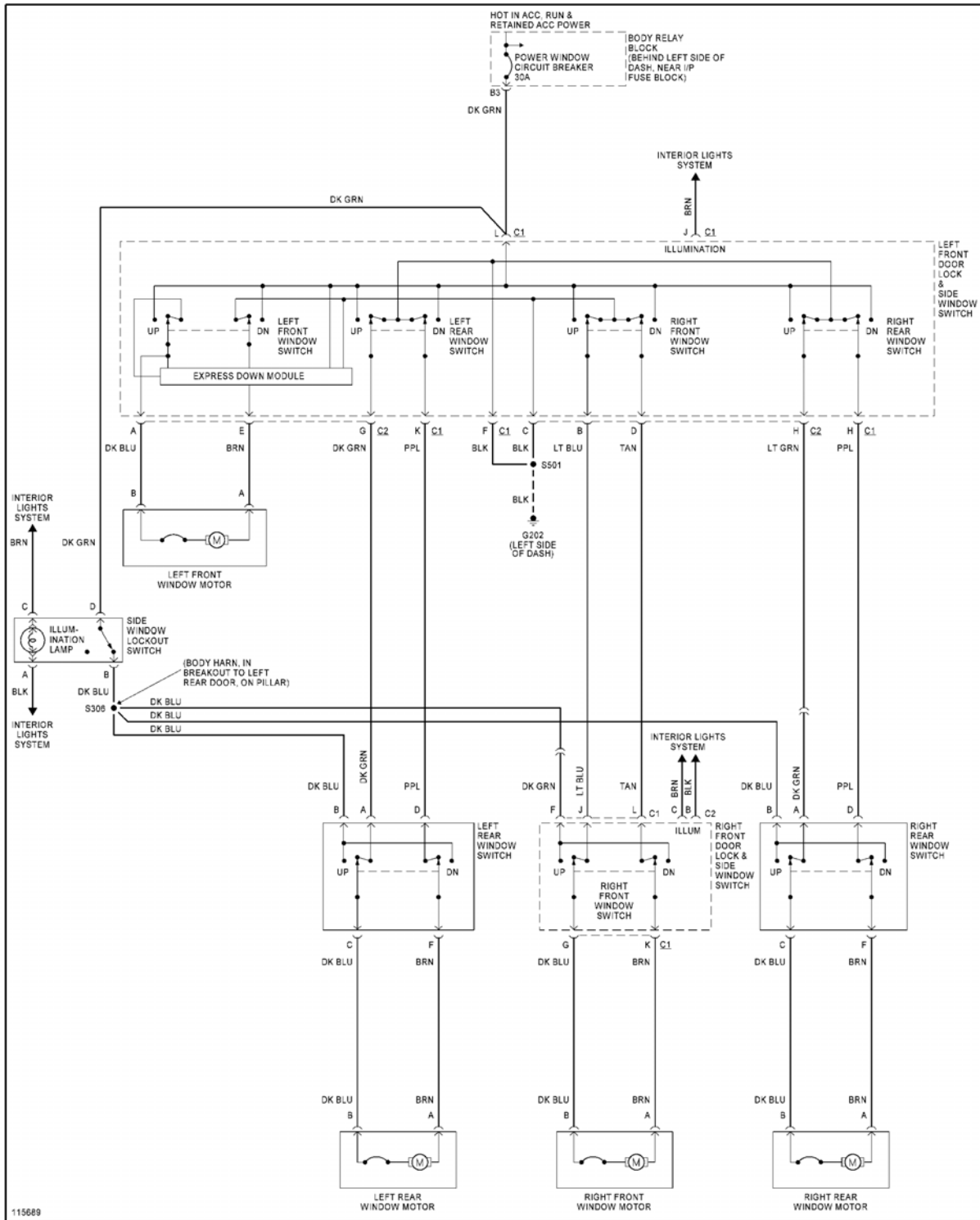

Fig. 46: Power Window Circuit, 4 Door



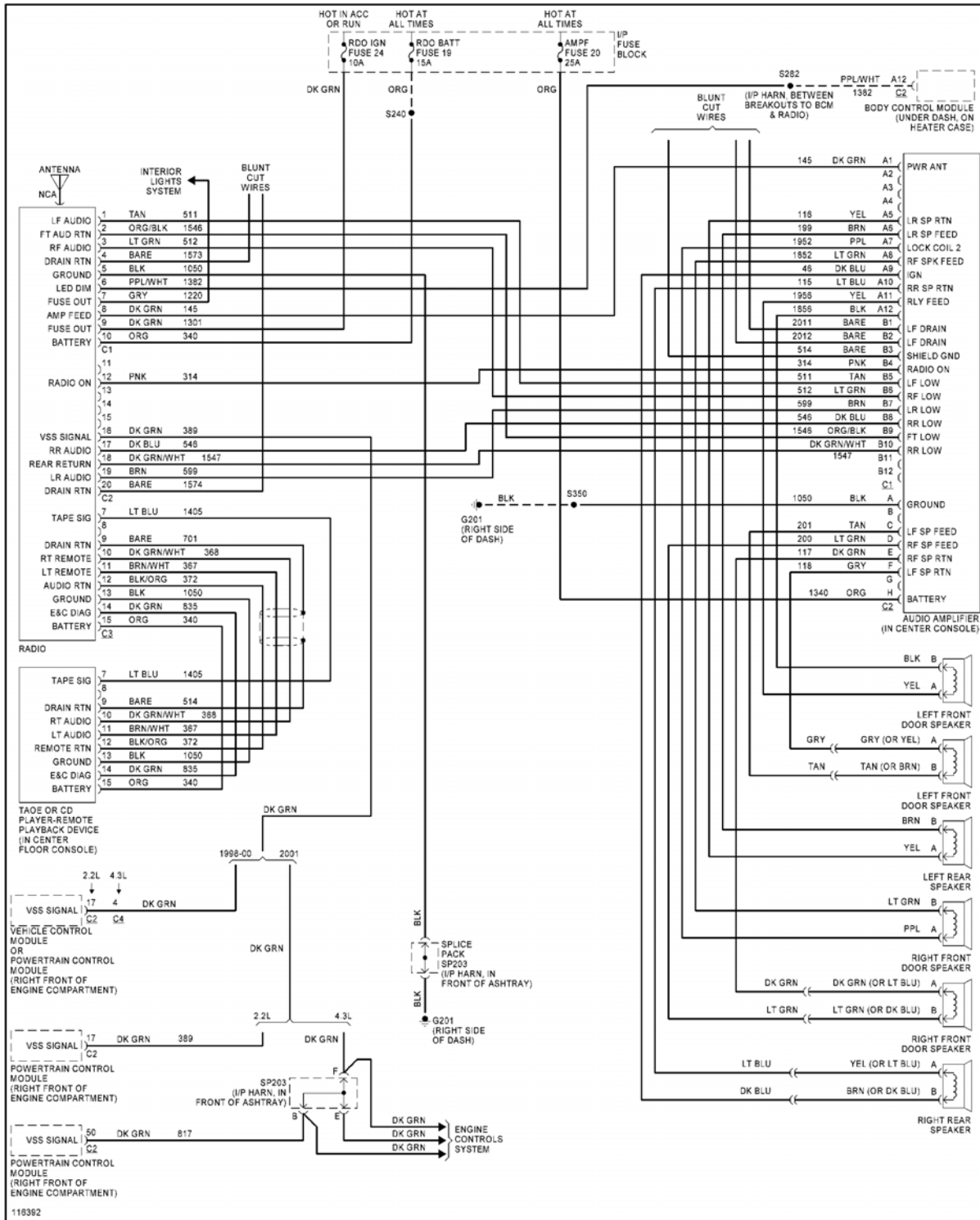

Fig. 47: Radio Circuits, W/ Amplifier

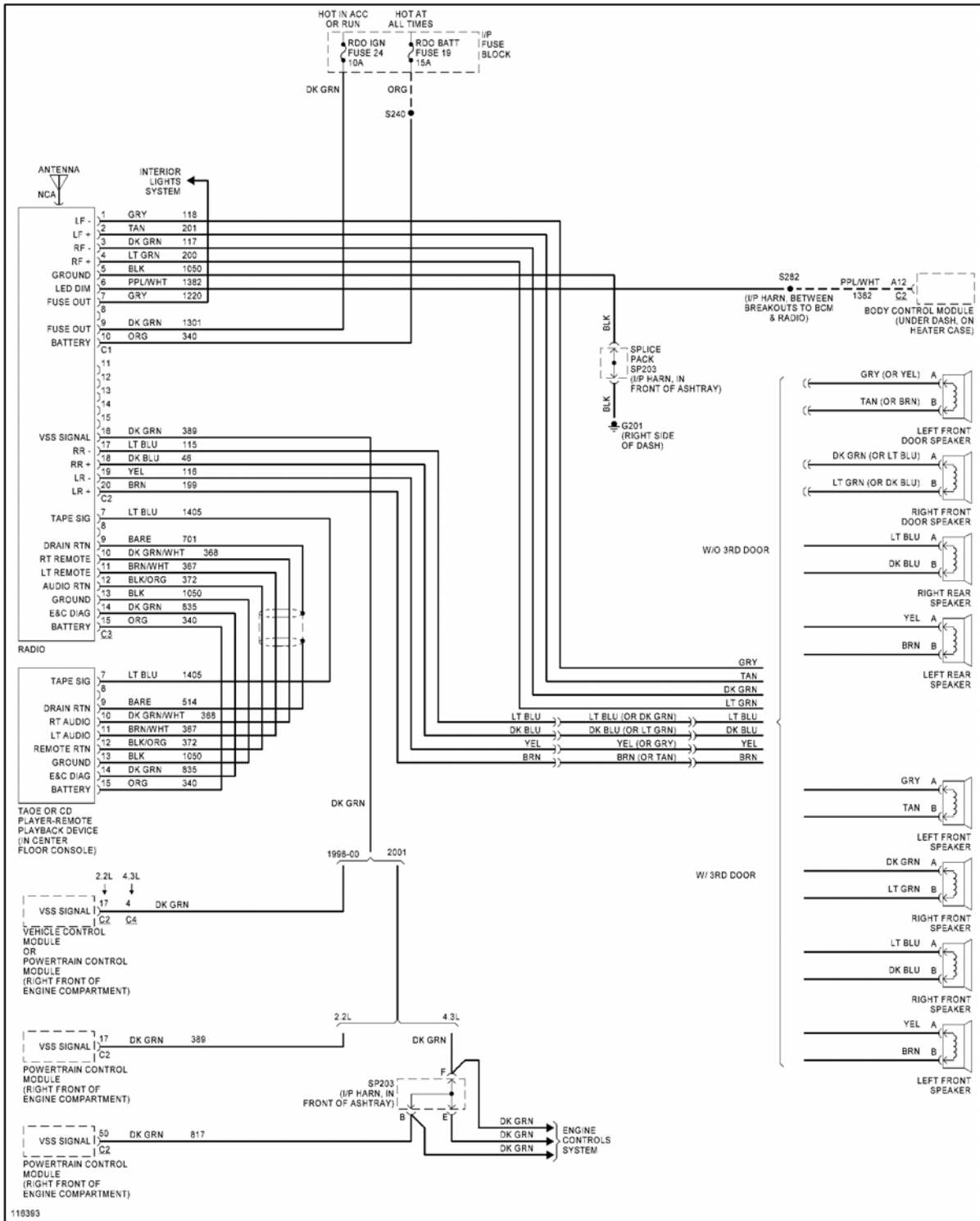

Fig. 48: Radio Circuits, W/O Amplifier

SHIFT INTERLOCKS 

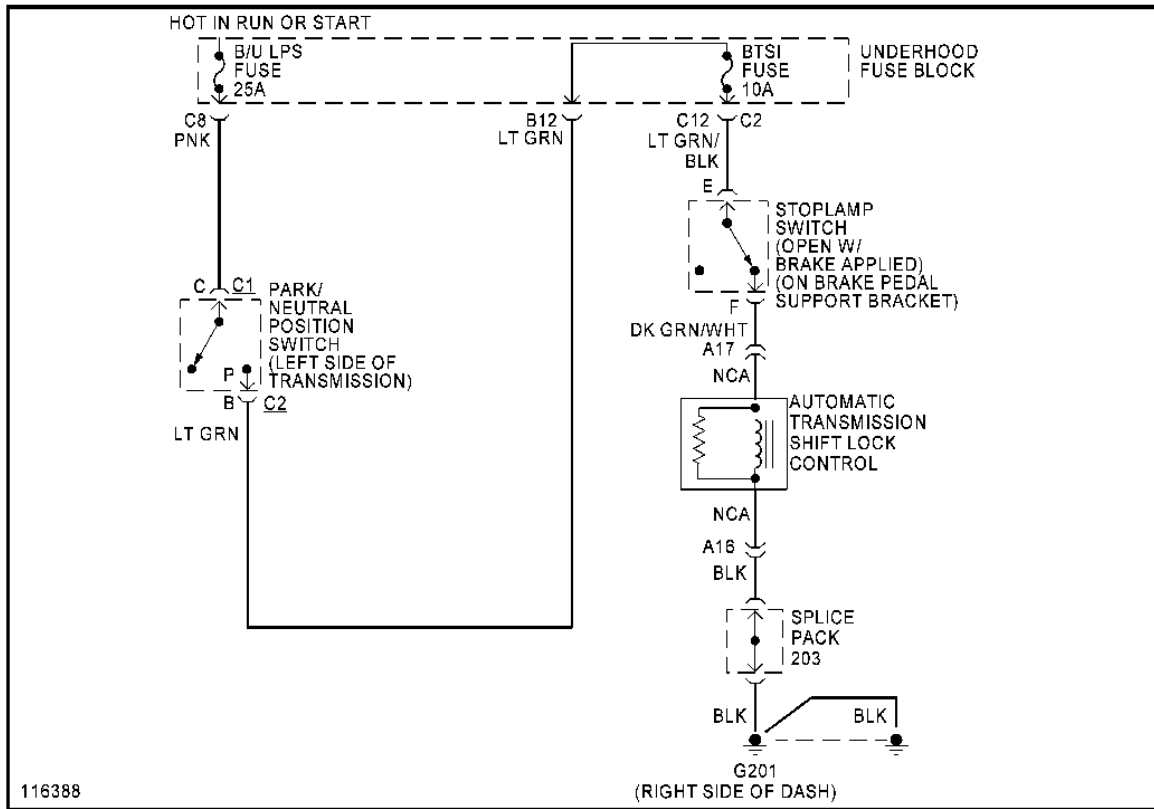

Fig. 49: Shift Interlock Circuit

STARTING/CHARGING 

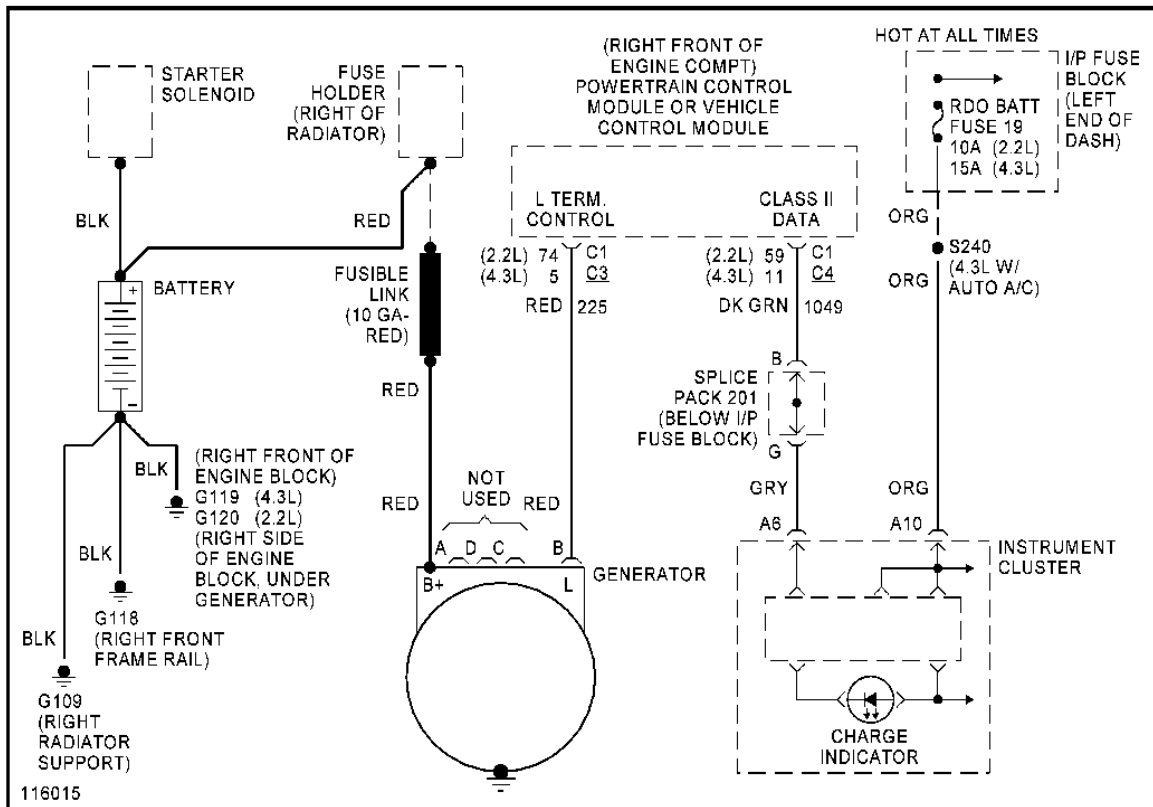

Fig. 50: Charging Circuit

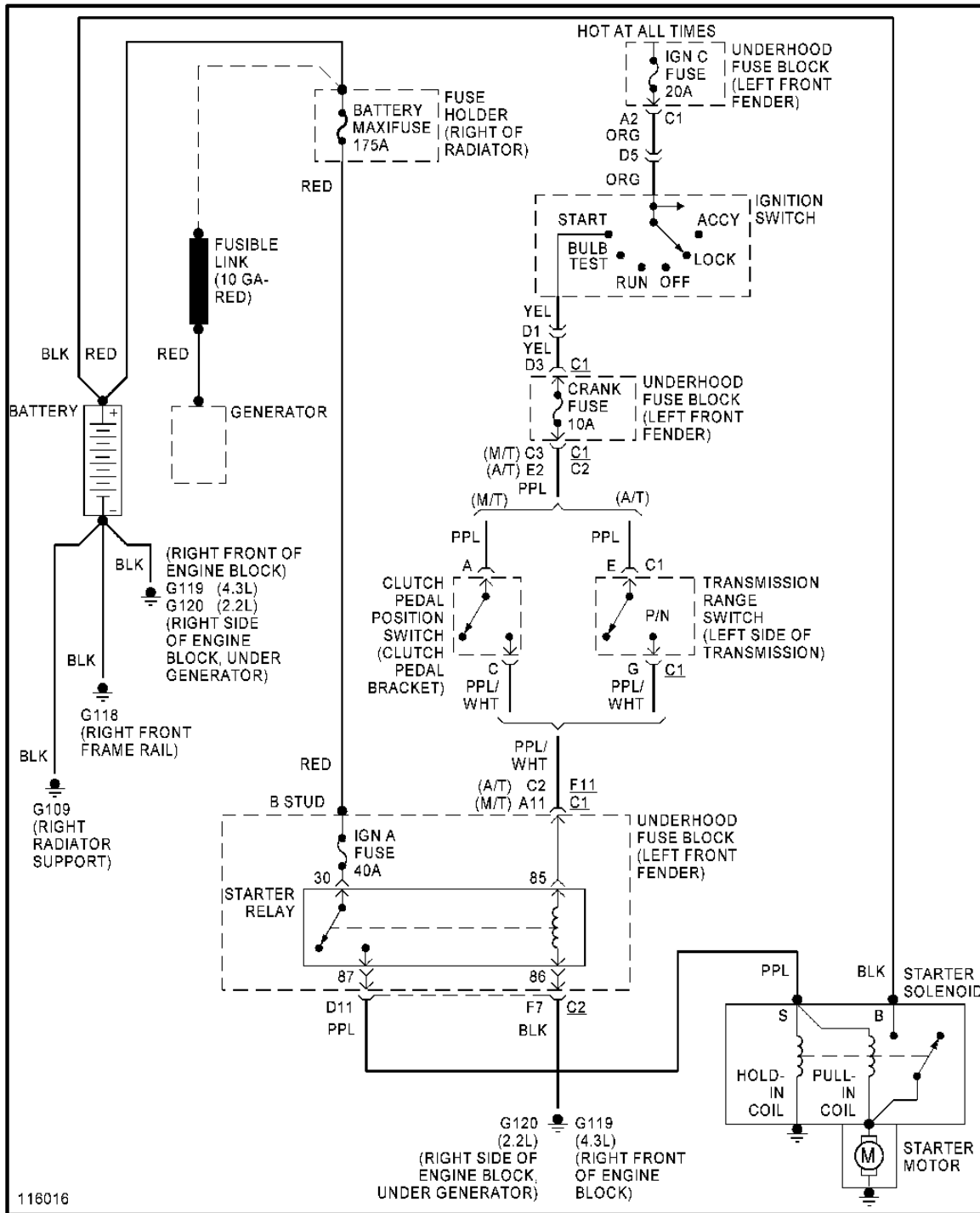

Fig. 51: Starting Circuit

SUPPLEMENTAL RESTRAINTS 

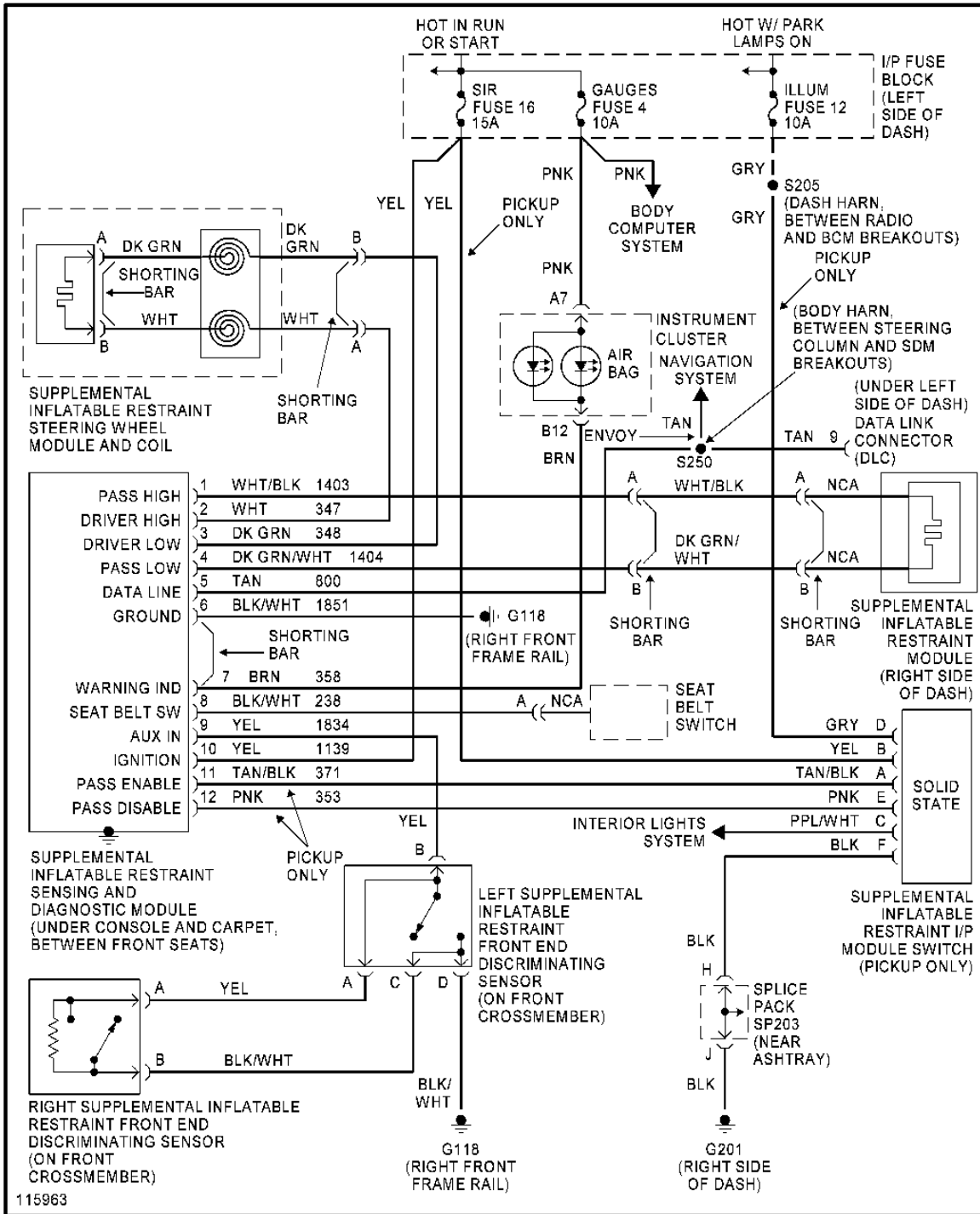

Fig. 52: Supplemental Restraint Circuit

TRANSMISSION

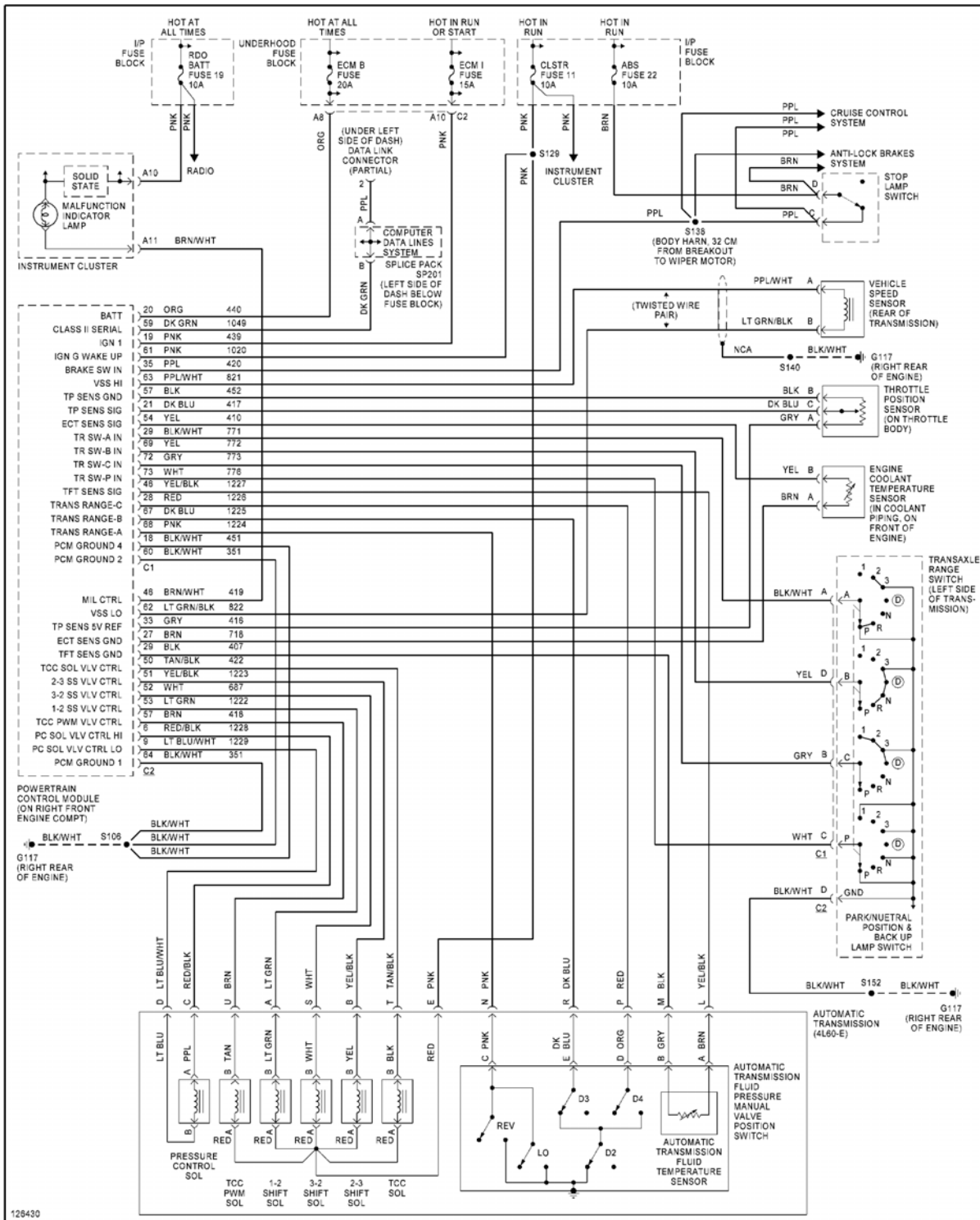

Fig. 53: 2.2L VIN 4, A/T Circuit, 4L60-E

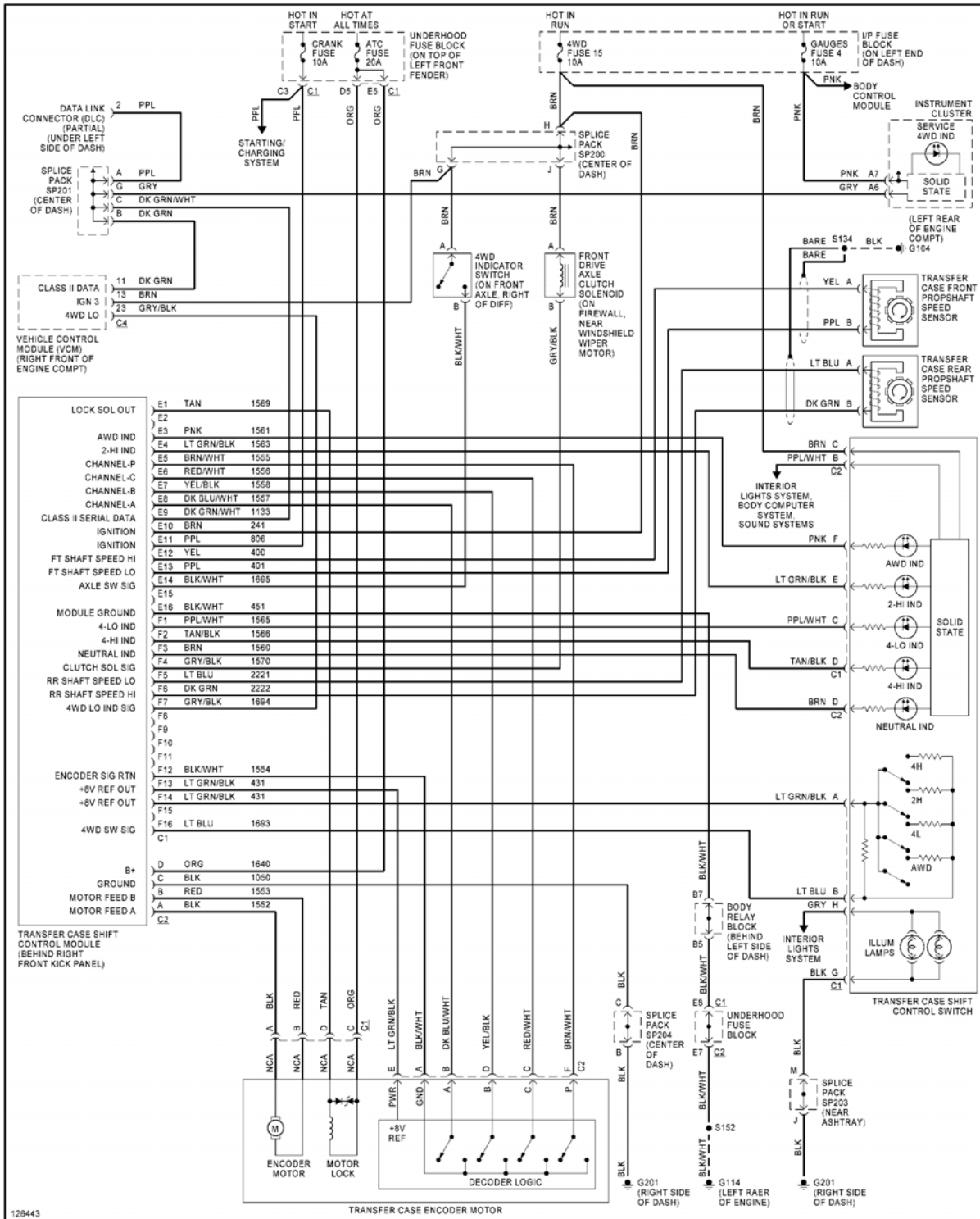

Fig. 54: 4WD Circuit, W/ 2-Speed Automatic Transfer Case

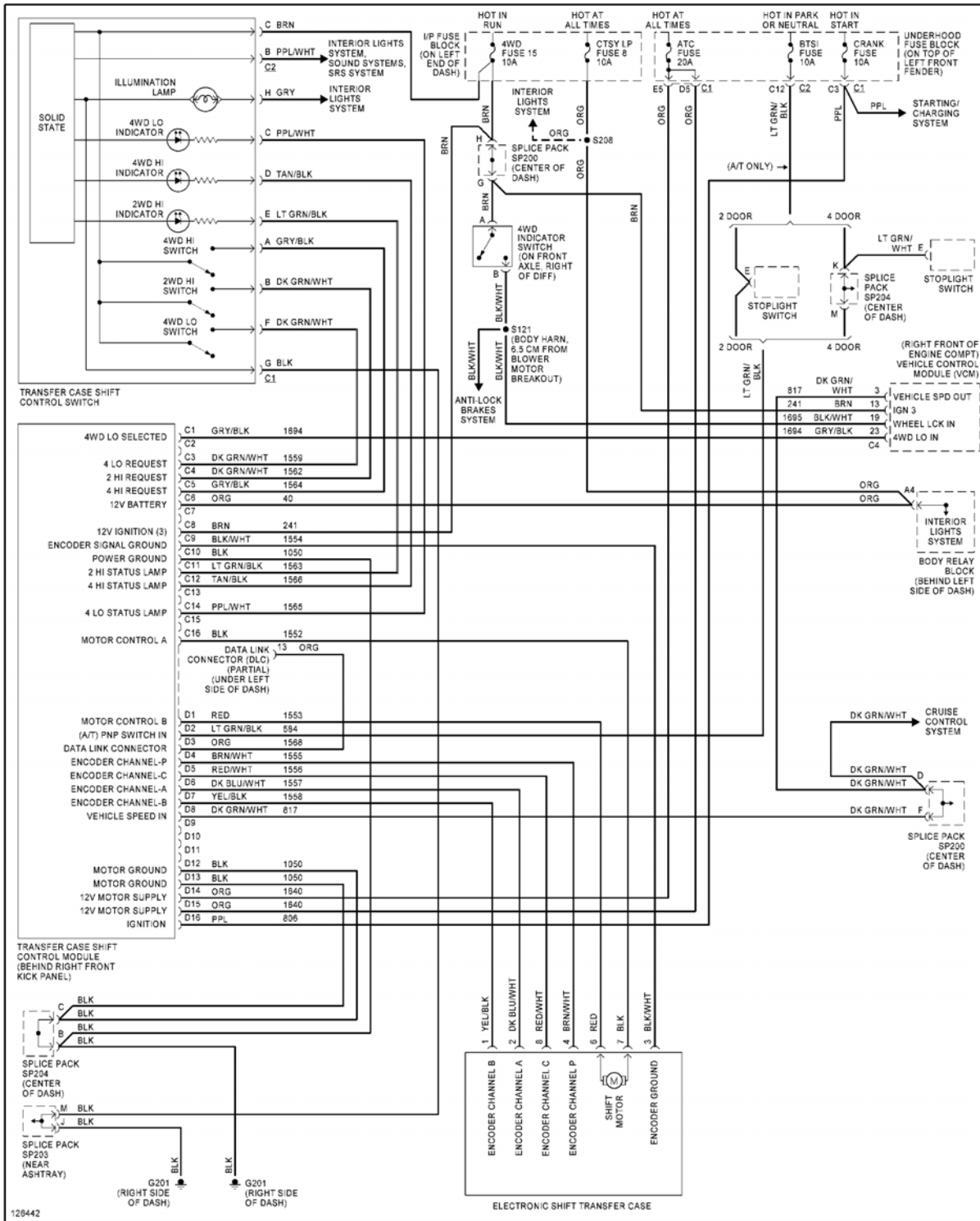

Fig. 55: 4WD Circuit, W/ 2-Speed Selectable Transfer Case

4.3L

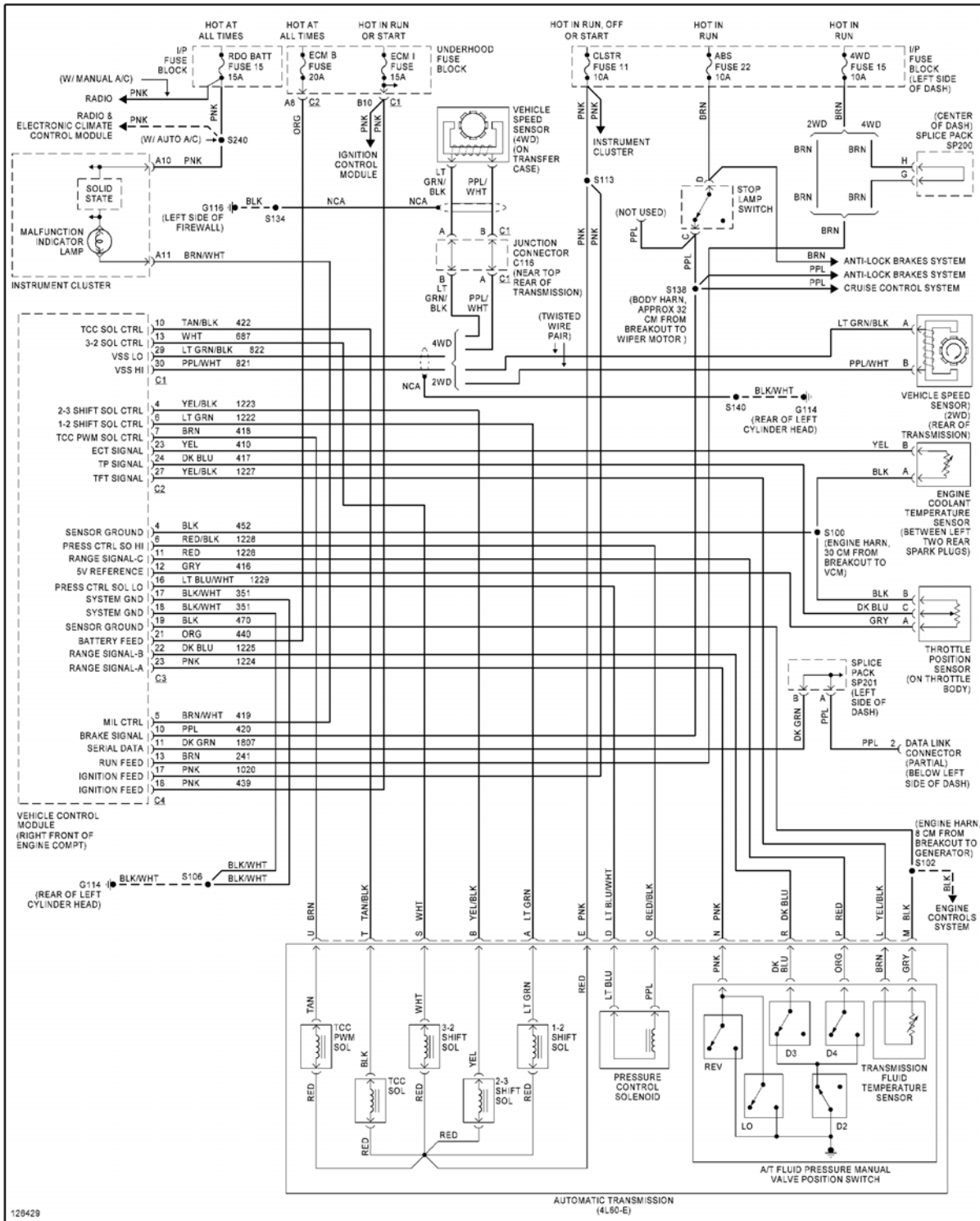

Fig. 56: 4.3L VIN W, A/T Circuit, 4L60-E

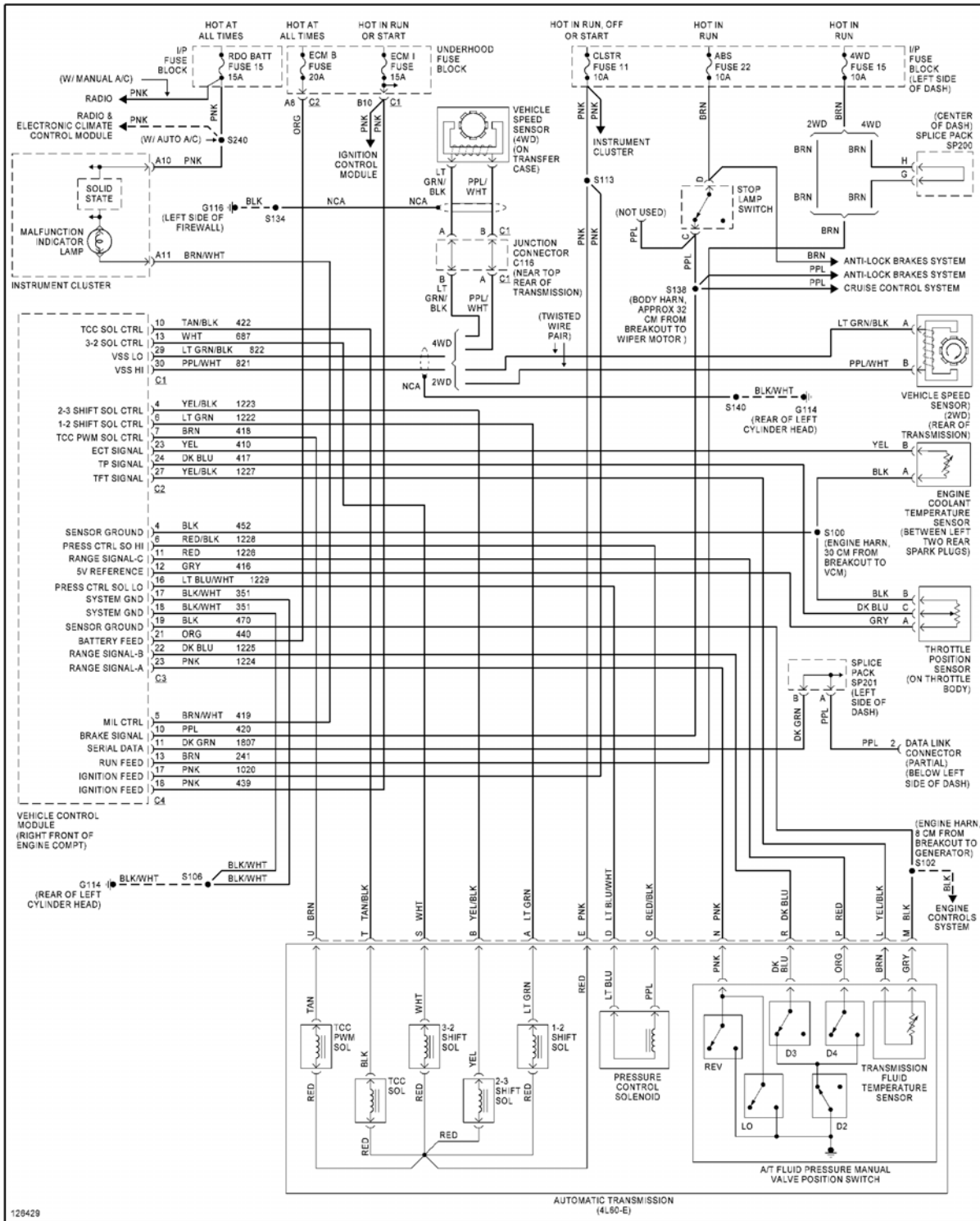

Fig. 57: 4.3L VIN X, A/T Circuit, 4L60-E

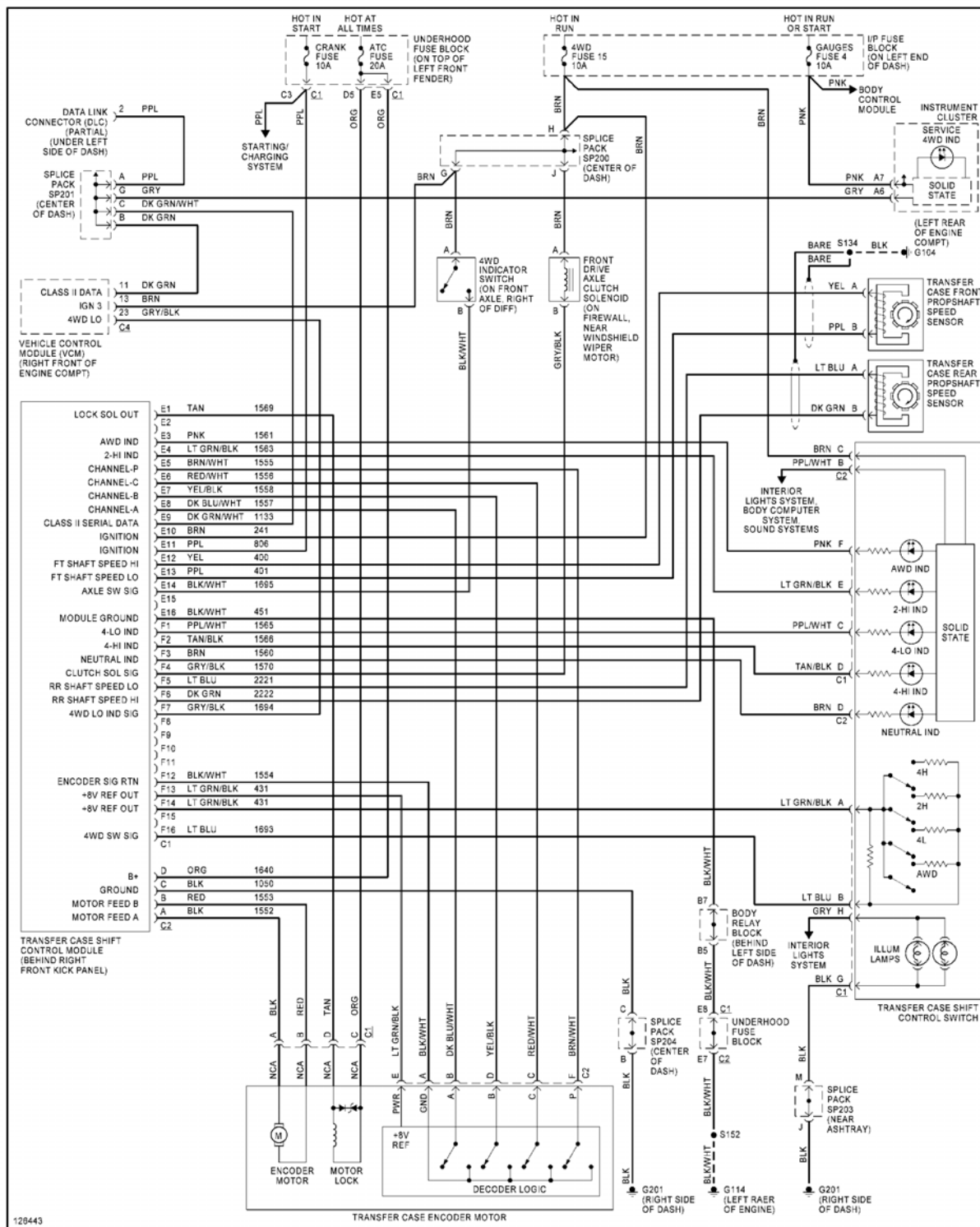

Fig. 58: 4WD Circuit, W/ 2-Speed Automatic Transfer Case

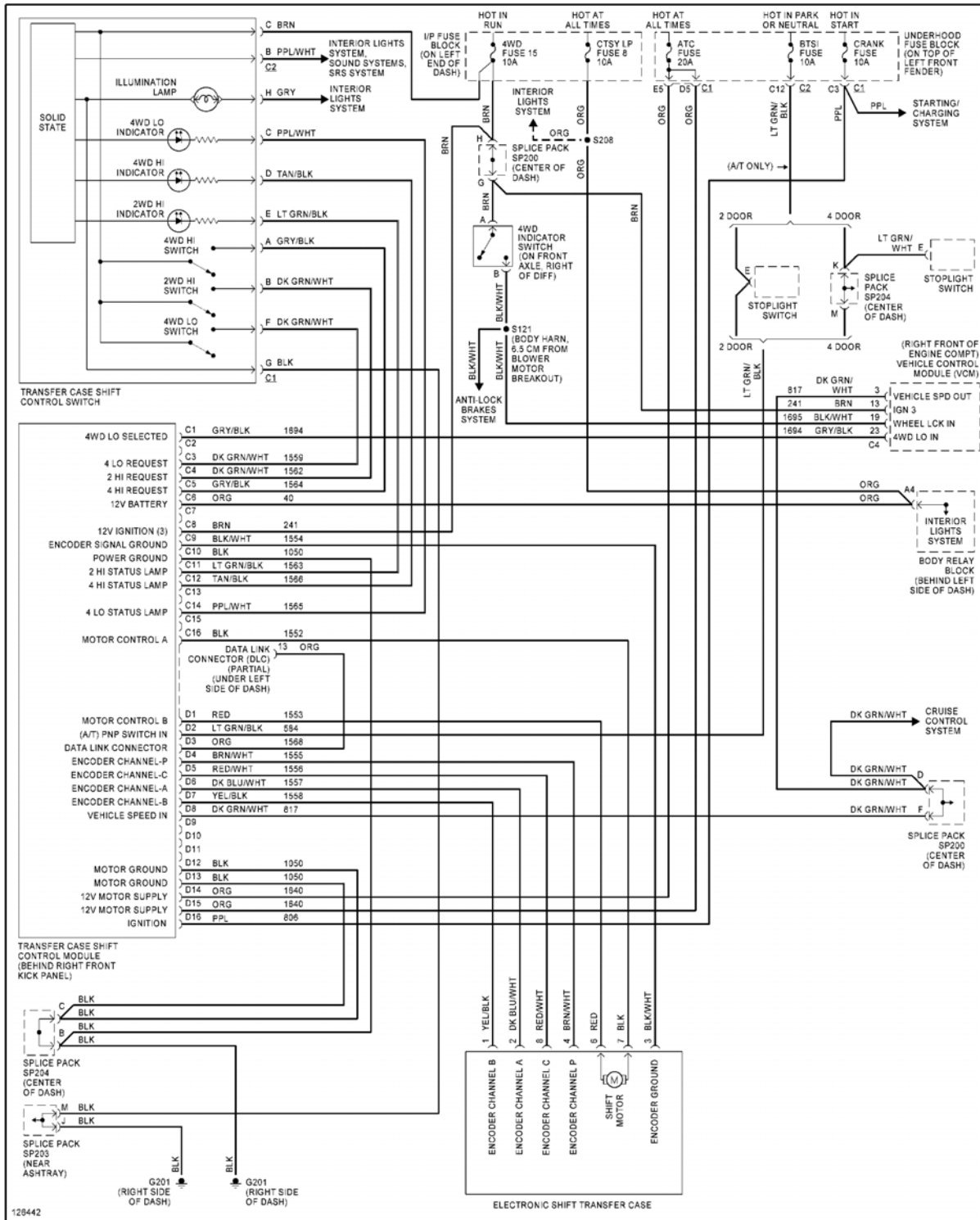

Fig. 59: 4WD Circuit, W/ 2-Speed Selectable Transfer Case

WARNING SYSTEMS

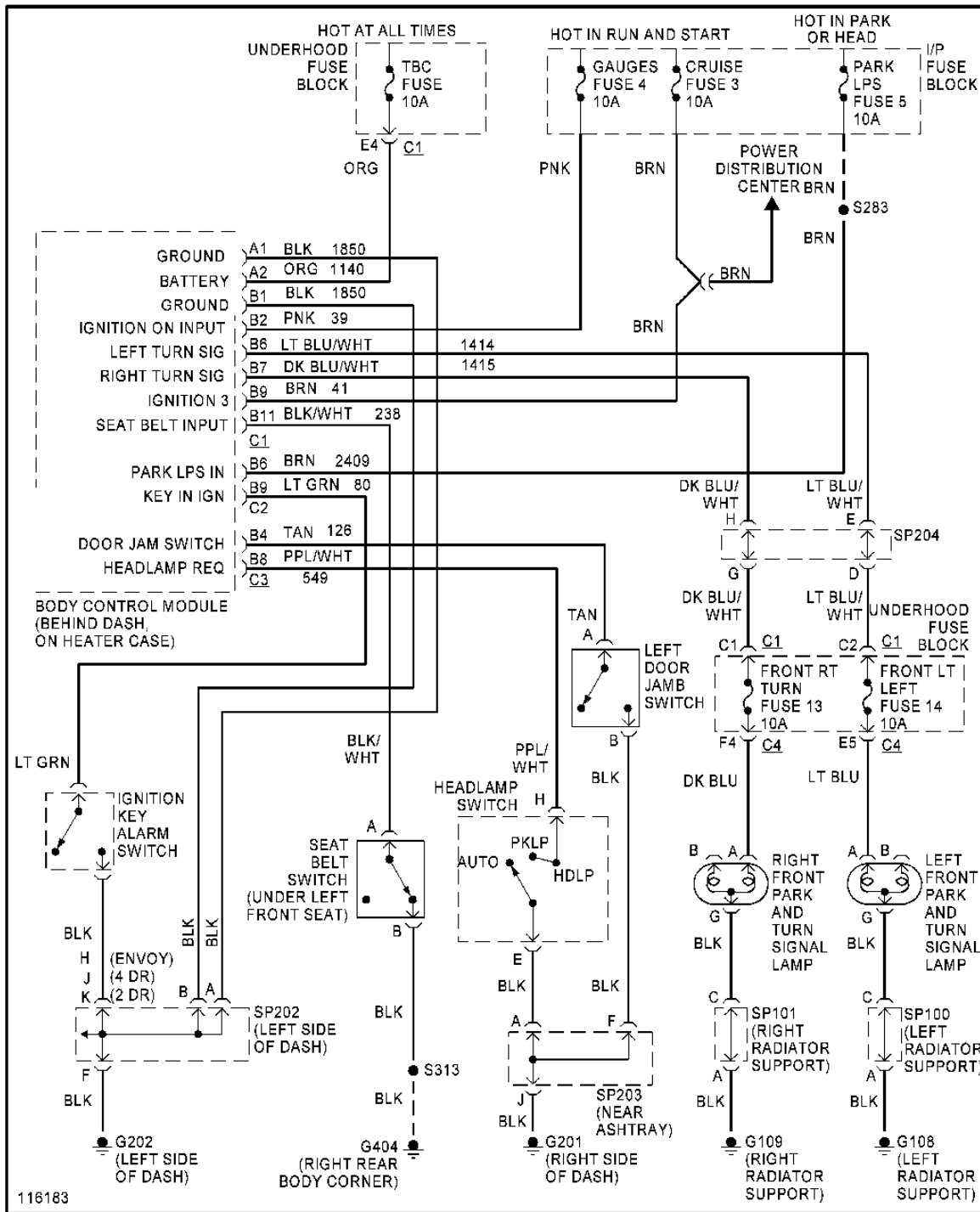

Fig. 60: Warning System Circuits

WIPER/WASHER 

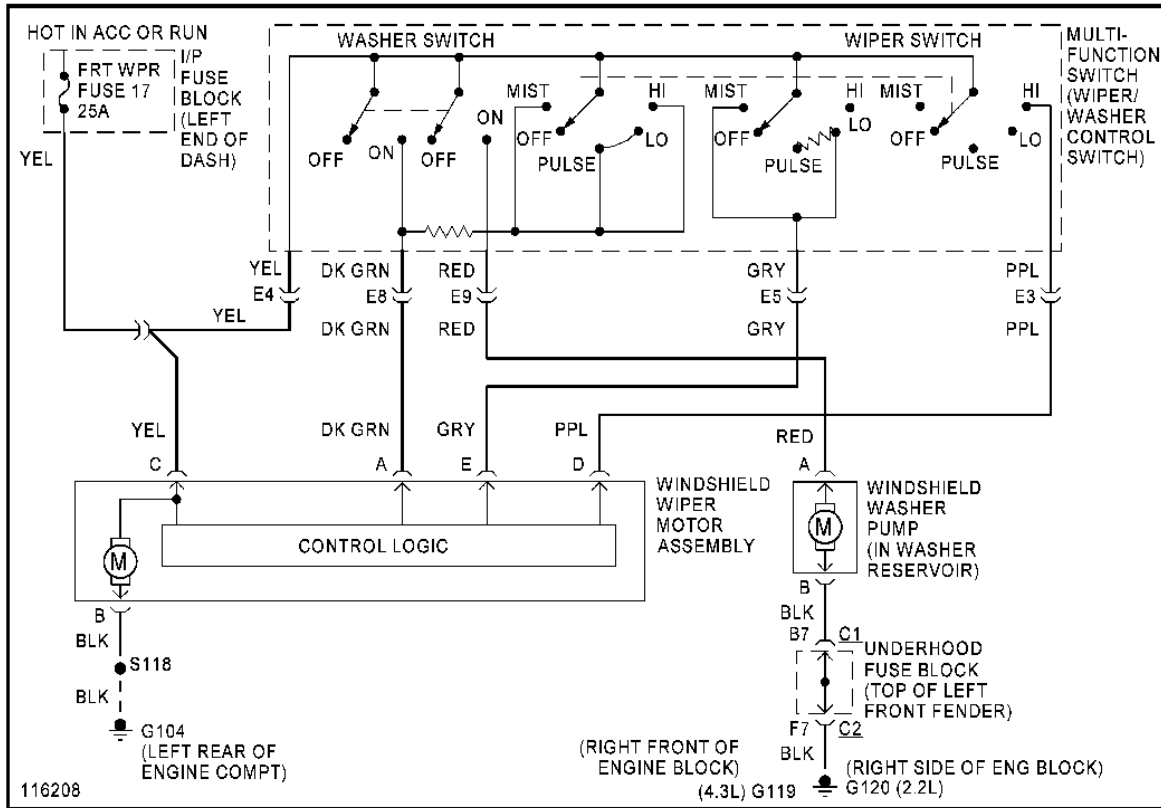

Fig. 61: Front Wiper/Washer Circuit

© 2008 Mitchell Repair Information Co., LLC.