

Installation Manual

1967-72 Chevrolet Pickup

DOCUMENT #1-2033

©2018 Classic Auto Air / 12.18





Congratulations...

You have just purchased the highest quality, best performing A/C system ever designed for your 1967-72 Chevrolet Pickup.

To obtain the high level of performance and dependability our systems are known for, please pay close attention to the following instructions. Our installation steps and procedures are derived from a long history of research and development and the combined experience achieved thru thousands of successful installations (and feedback from customers like you). Please remember that our #1 goal is that you'll have a successful installation and a system that performs at a very high level for many years to come.

Before starting, read the instructions carefully, from beginning to end, and follow the proper sequence. On the next page you'll find a safety and general checklist that you should read before starting your installation.

Again, thank you from our entire staff.



Check List, Pre-Installation:

- Before beginning the installation check the shipping box for the correct components. YOUR BOXED UNIT INCLUDES A LIST OF MAJOR COMPONENTS AND A LIST OF BAGGED PARTS. We have a 5 stage check process to make sure you have everything you'll need.
- If your vehicle has been or is being modified, some procedures will need to be adjusted to fit your particular application.**
- A basic cleaning of the engine compartment and interior before beginning will make things go more smoothly.
- Check condition of engine mounts. Excessive engine movement can damage hoses to A/C and/or heater.
- Before starting, check vehicle interior electrical functions (interior lights, radio, horn, etc). Make a note of anything that does not work as it's supposed to. During the installation you might find the opportunity to repair or upgrade non-working or out of date components. When you're ready to start the installation, **DISCONNECT THE BATTERY FIRST.**
- Drain the radiator. Retain the coolant and reuse, or dispose of properly.
- SAFETY FIRST: Wear eye protection while drilling/cutting, deburr sharp edges, and never get in a hurry or force a part.
- Tools: Your installation only requires the basic tools everyone has in their garage, nothing exotic or specific to A/C or Heat equipment.

Procedures, During Installation:

- Fittings: Use one or two drops of mineral oil (supplied with your kit) on ALL rubber o-rings, threads and rear of bump for o-ring where female nut rides. Do not use thread tape or sealants.
- Measure twice (or more), cut once
- Should you have any technical questions, or feel you have defective components (or missing items), call us immediately, we will be glad to assist you. Our toll-free number is listed on every page, we're here to help!**

YOU CAN NOW BEGIN THE INSTALLATION...

A Basic Overview of Automotive A/C....

- 1 Evaporator with Blower Fan** In order to remove the heat from the air in the vehicle, the A/C evaporator allows the refrigerant to absorb the heat from the air passing over it. The blower fan moves cool air out into the car interior.
- 2 Compressor** The compressor pumps and circulates the refrigerant through the system.
- 3 Condenser** The condenser is a heat exchanger mounted at the front of the vehicle. Heat drawn out of the interior of the car is expelled here.
- 4 Receiver/Drier** The drier not only dries refrigerant, it also filters the refrigerant and stores it under certain operating conditions.
- 5 High Pressure Switch** A pressure switch is used to shut down the system if high or low pressure is detected, basically it acts as a safety switch.

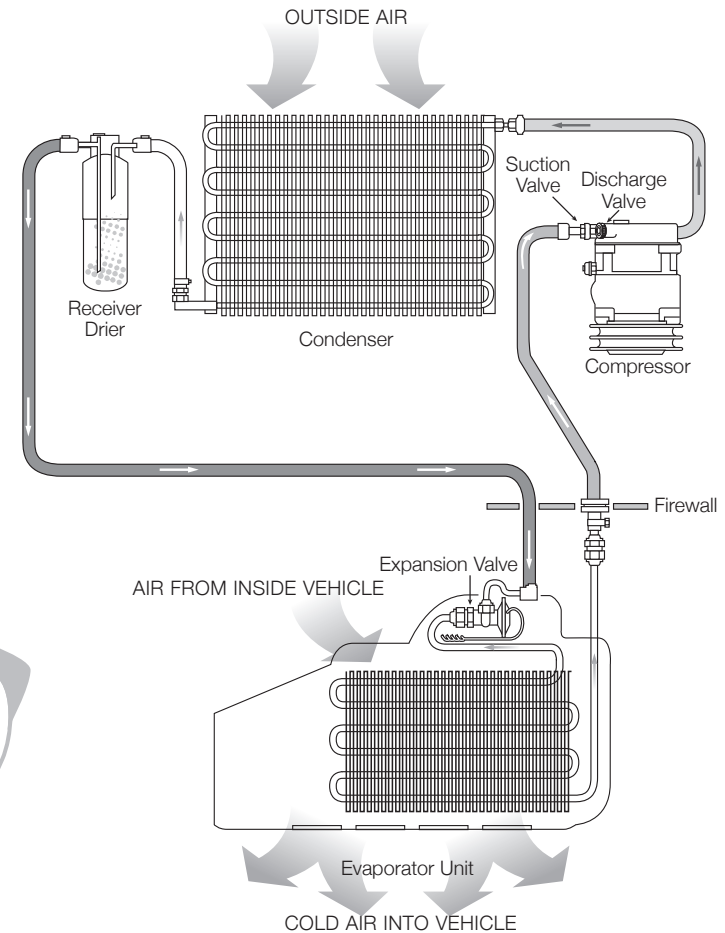
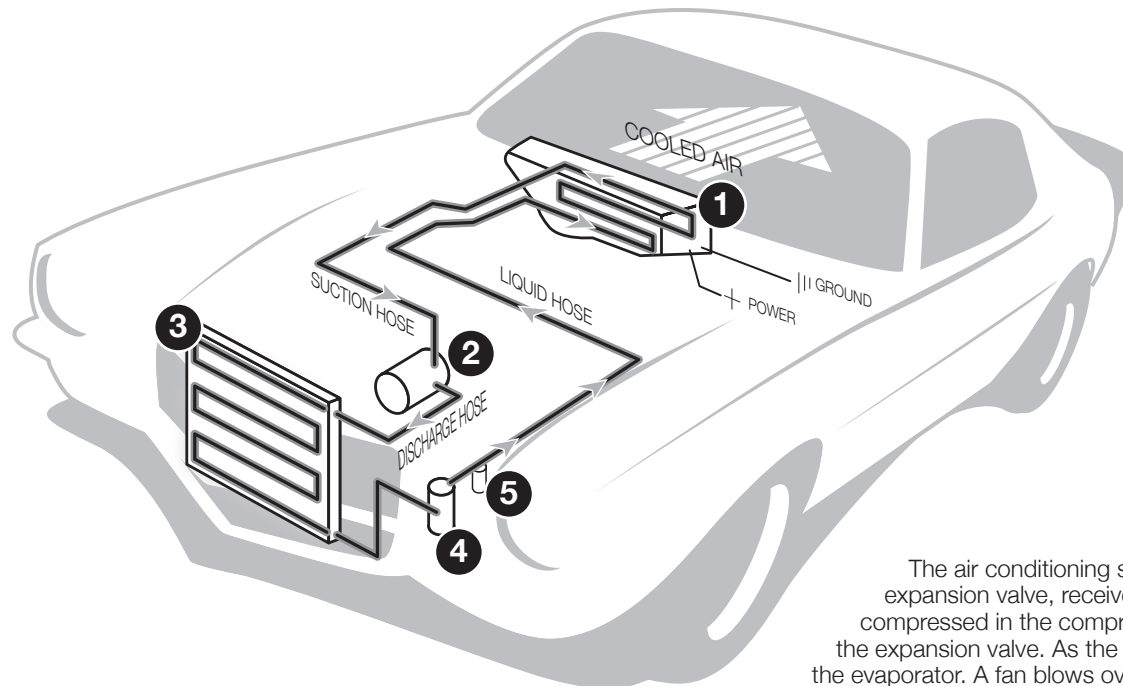

The air conditioning system in your car is comprised of a compressor, condenser, expansion valve, receiver/drier, and evaporator. Refrigerant (also known as Freon) is compressed in the compressor. In the condenser, gas is cooled to a liquid state and travels to the expansion valve. As the liquid refrigerant goes through the expansion valve it rapidly cools in the evaporator. A fan blows over the evaporator and cools the air that blows out your vents.



Control & Operating Instructions

Your new Perfect Fit-Elite system offers complete comfort capabilities in virtually every driving condition. This includes temperature control in all of the modes. This system also provides the ability to blend the air between Face, Heat, and Defrost modes simultaneously. To illustrate the various ways you can adjust the airflow direction and temperature - we've provided these handy illustrations and chart to show exactly how you can adjust your Perfect Fit-Elite for maximum comfort...

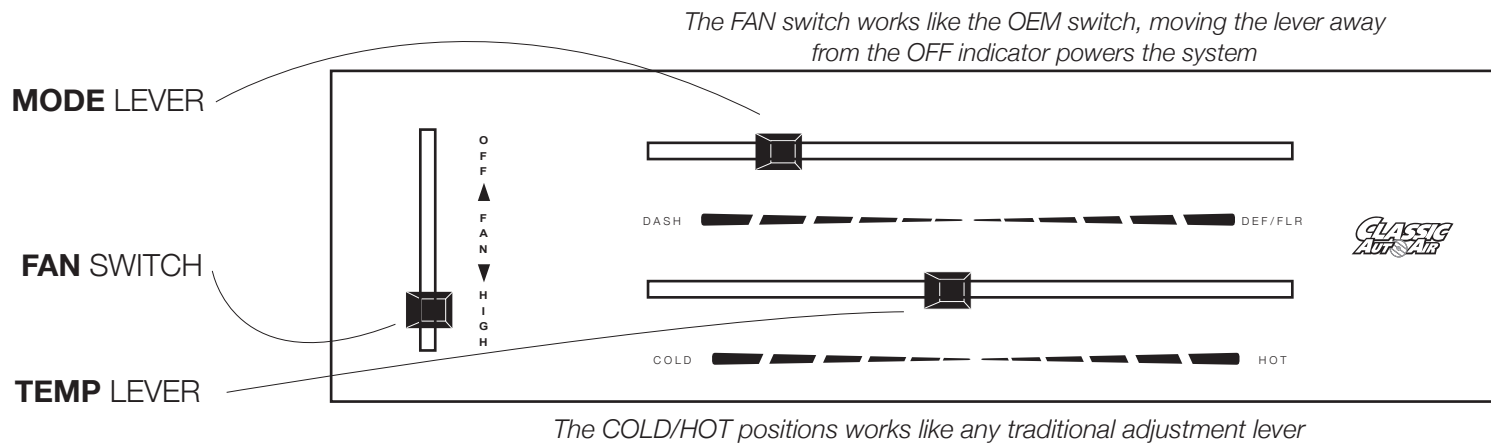

There are 11 levels of adjustment within the range of the DASH/DEF lever

	DASH										DEF/ FLOOR
Left Lever Position	1	2	3	4	5	6	7	8	9	10	11
Distribution	Dash 100%	Dash 90%	Dash 80%	Dash 70%	Dash 60%	Dash 50%	Dash 40%	Dash 30%	Dash 20%	Dash 10%	Floor 100%
		Defrost/Floor 10%	Defrost/Floor 20%	Defrost/Floor 30%	Defrost/Floor 40%	Defrost 50%	Defrost 60%	Defrost 70%	Defrost 80%	Defrost 90%	Defrost 100%
Compressor State	ON										ON

Moving to the engine compartment:

In order to remove your heater assembly it is necessary to remove the heater case housing first.

Located on the engine side of the firewall, remove seven (7) bolts around the perimeter of the heater case housing (see Figure 7). Remove the housing (Discard).

NOTE: To remove the two bolts at locations 1A and 7B, it may be necessary to lower the inner fender. Retain these screws.

Drain coolant from radiator. Remove the heater hoses from heater coil and firewall (see Figure 8).

You will also cut a power lead to the blower motor. This will not be re-used.

FIGURE 7

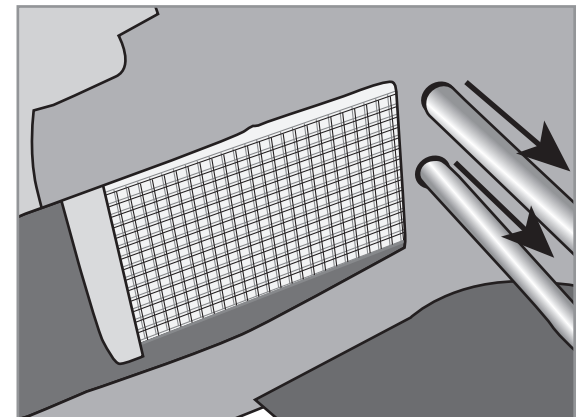
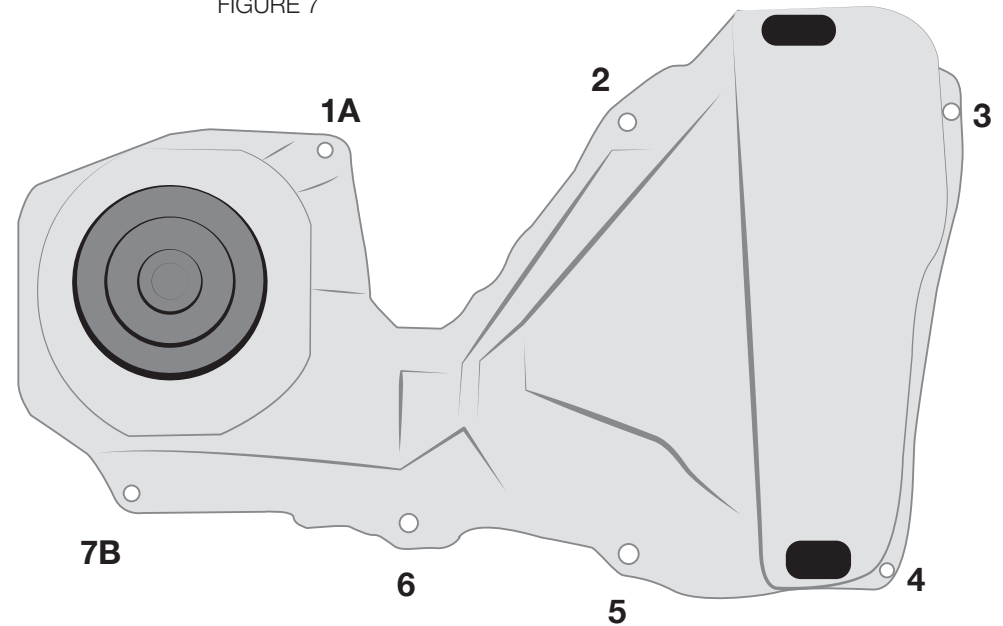

FIGURE 8



Remove Glovebox, Console (if equipped), Radio OEM heater controls and defrost duct, set aside for modification and reinstall later (see figure 1).

The removal of the Original Heater Assembly can be accomplished by disconnecting three control cables. One is attached to the Heat/Defrost door (see figure 2). One is attached to the Temperature door, and one is attached to the Vent / Heat door (see figure 3). Disconnect the electrical harness from the assembly. Also remove attachment screw located in front of the air inlet (see figure 4).

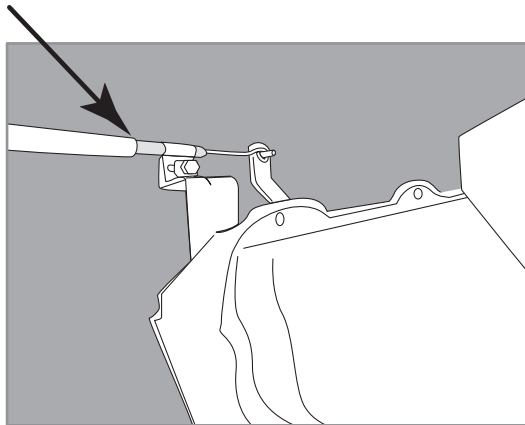
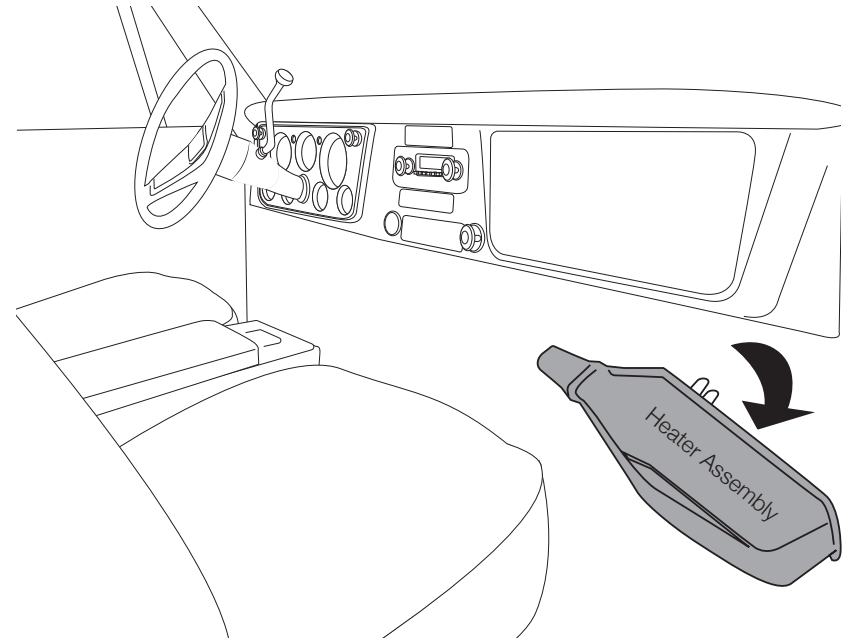

FIGURE 2

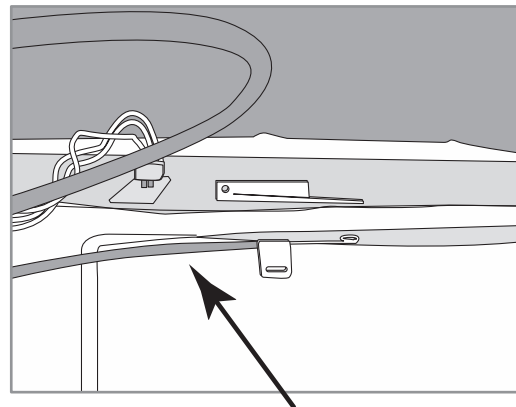

FIGURE 3

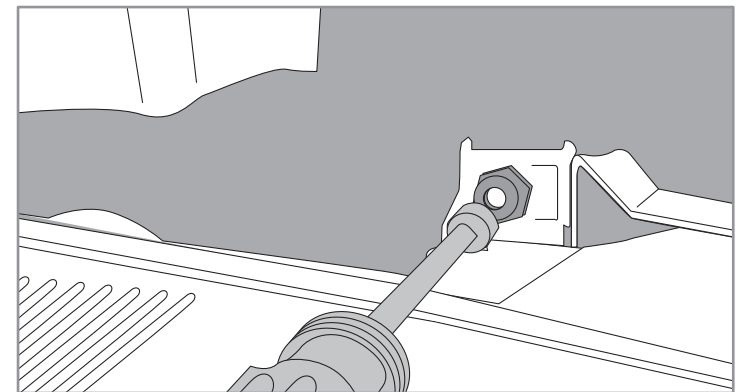
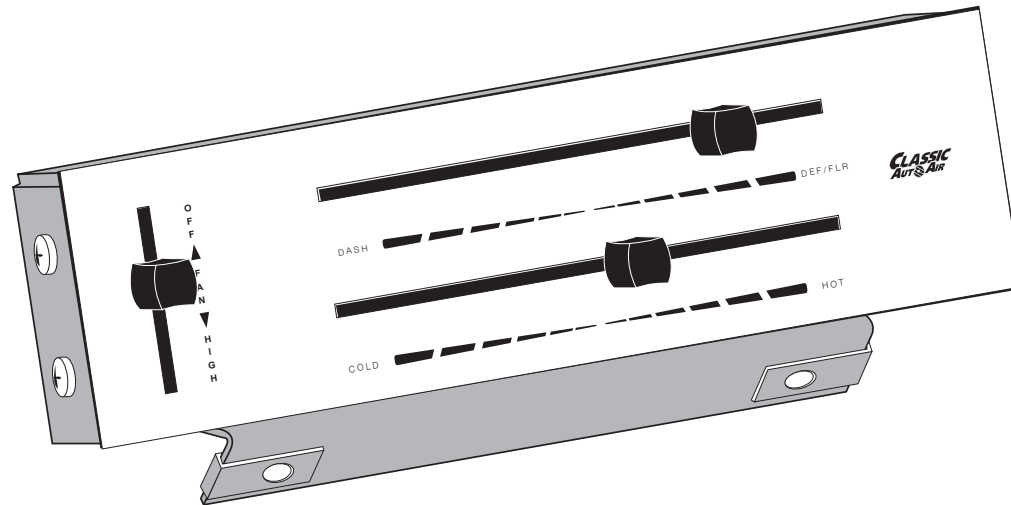

FIGURE 4

THESE ARE THE PARTS YOU WILL FIND IN BAG KIT A
(D.E.R. Controller)



D.E.R. Control
PN#16-3033

THESE ARE THE PARTS YOU WILL FIND IN BAG KIT B

You will use all of these parts and hardware during the next series of installation steps.

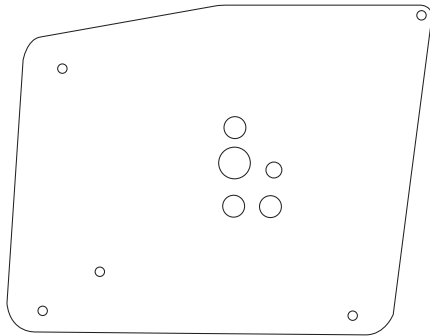

Firewall Block Off
PN#10-1033-4

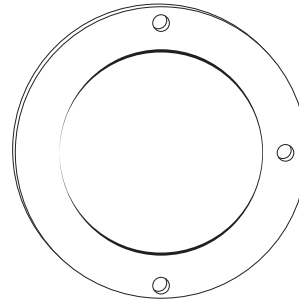

Fresh Air Inlet Block Off
PN#10-1033-3

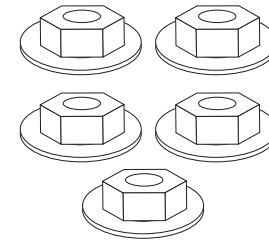

Flange Nuts

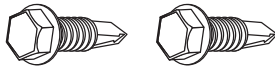

Two #14 - 16 x 3/4" Tek Screws



Two #10 x 5/8" Phillips Screws

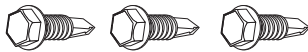

Three #10 - 16 x 3/4" Tek Screws



One Male Spade Connector

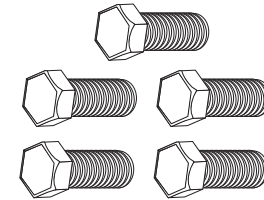

Five 1/4 - #20 x 5/8" Bolts

Illustrations NOT shown actual size

Within the engine compartment area, Install Fresh Air inlet block-off PN# 10-1033-3 (from Bag Kit B) over the OEM fan opening. Attach using (3) #10-16 x 3/4 Tek Screws.

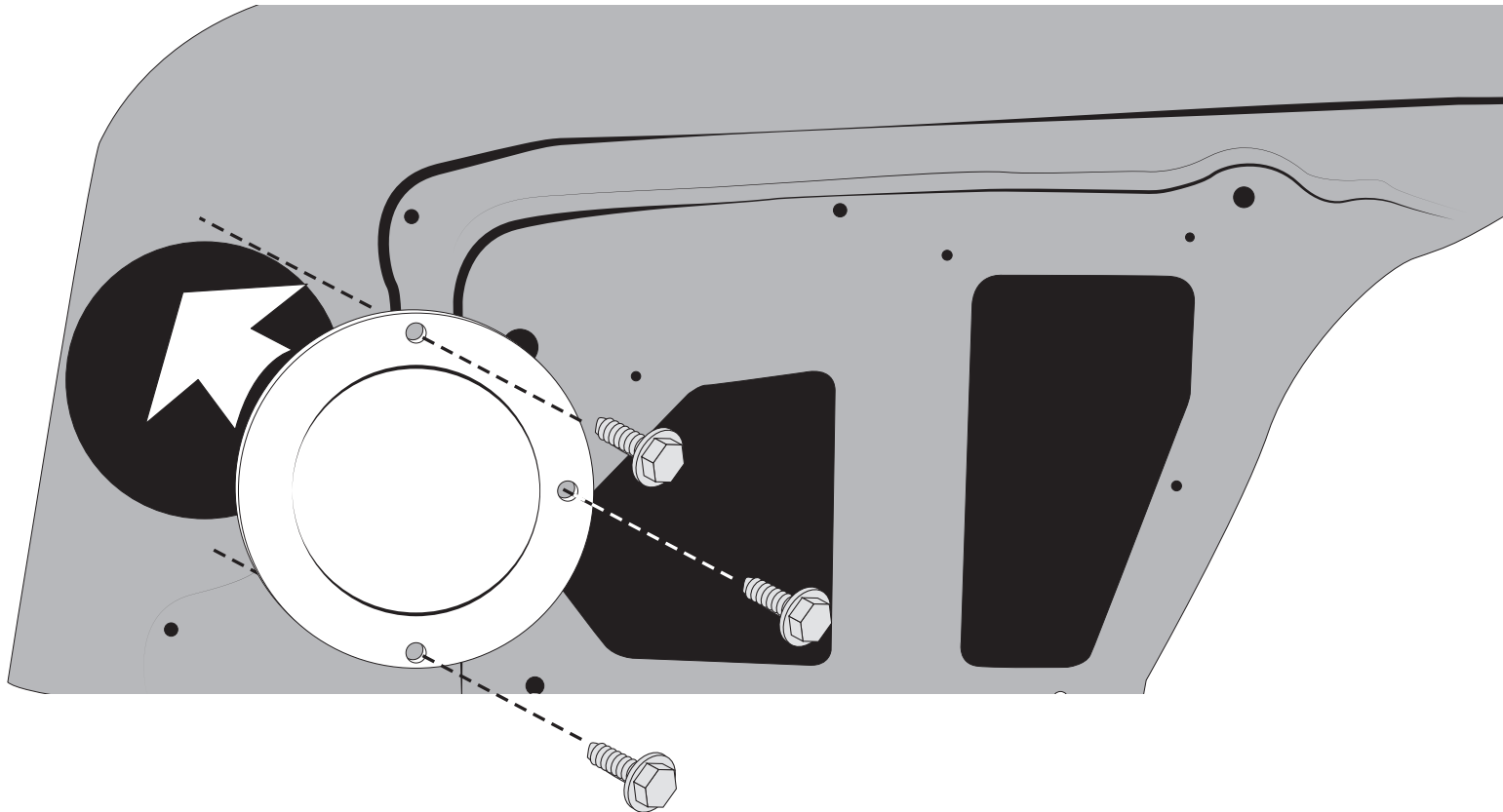

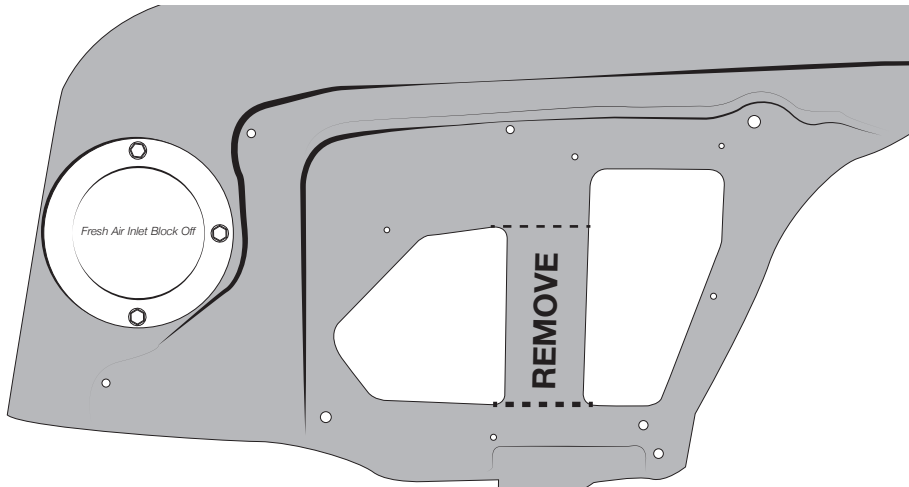
1

After Fresh Air Inlet Block off plate is installed you will need to cut the firewall. Both opening will need to merge and become one. Cut out middle section as shown.

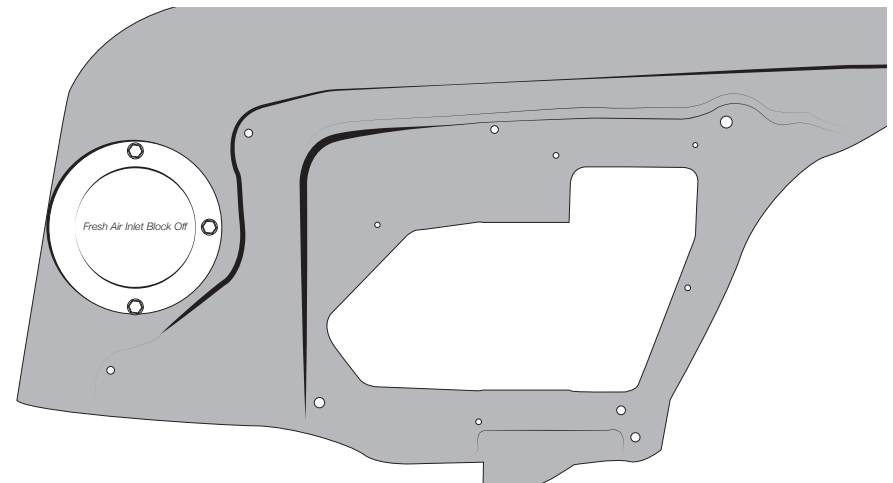
2

The opening in your firewall should look like this now.

3

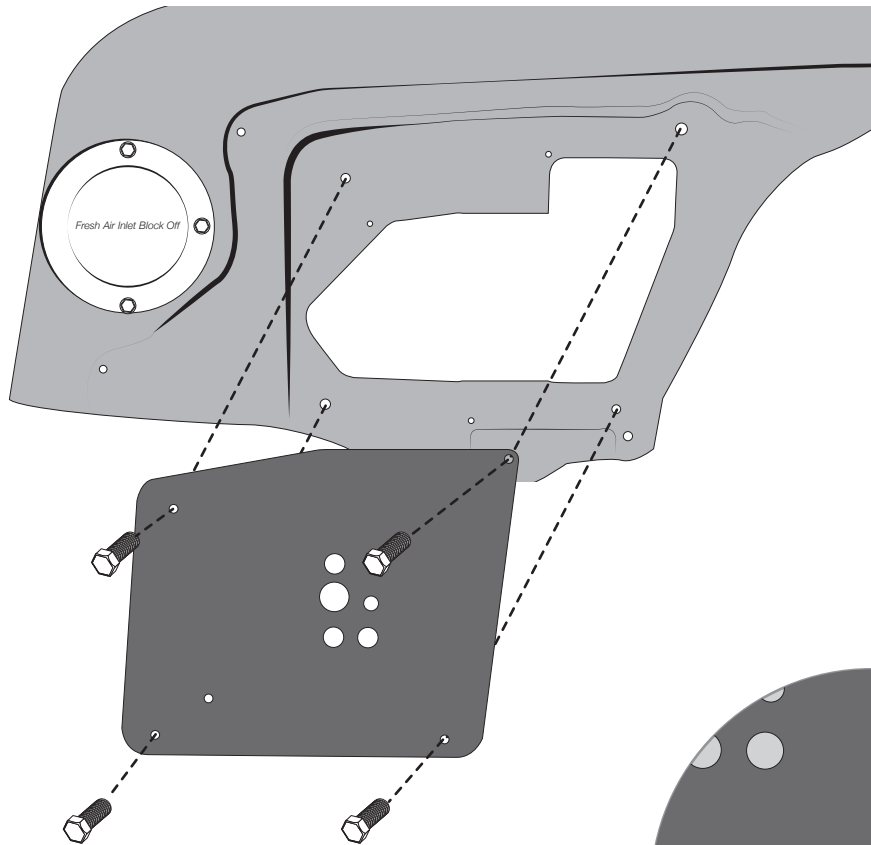

4

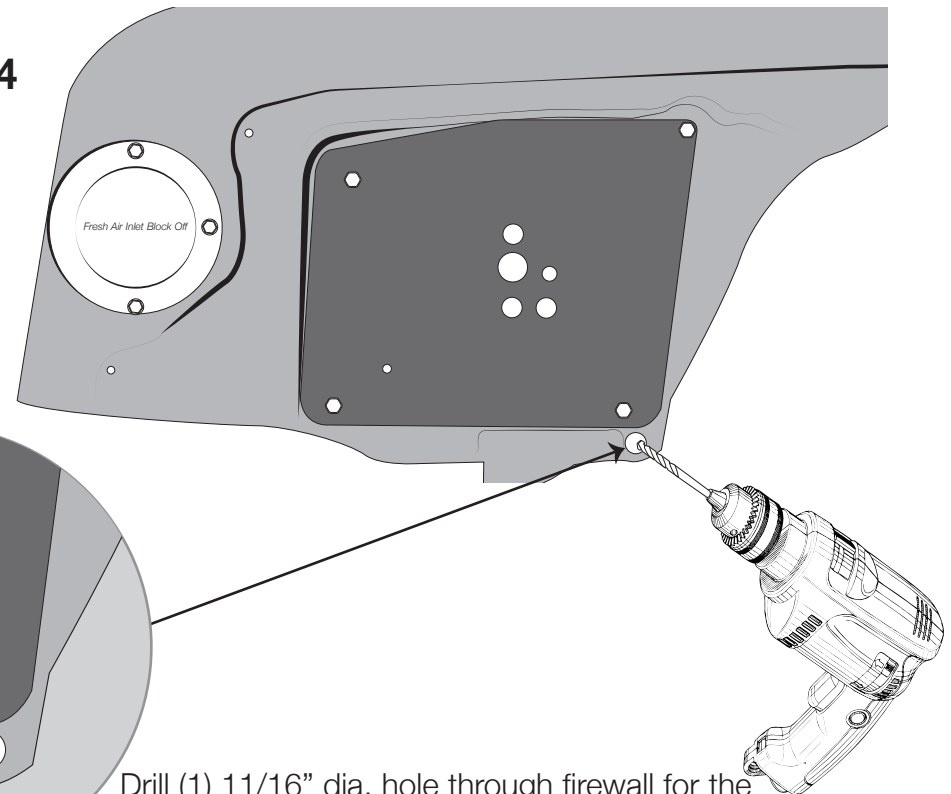

Attach Firewall Block Off Plate PN# 10-1033-4 to firewall using Four 1/4 - #20 x 5/8" bolt and (4) Flanged Nuts provided in Bag Kit B.

Drill (1) 11/16" dia. hole through firewall for the evaporator drain tube. You can choose to use a preexisting hole, as long it will be lower than the drain tube nipple when installed.

Remove Evaporator Unit and Defrost Assembly from box. The Defrost Assembly is pre-installed using Two #10 x 5/8" Phillips Screws.

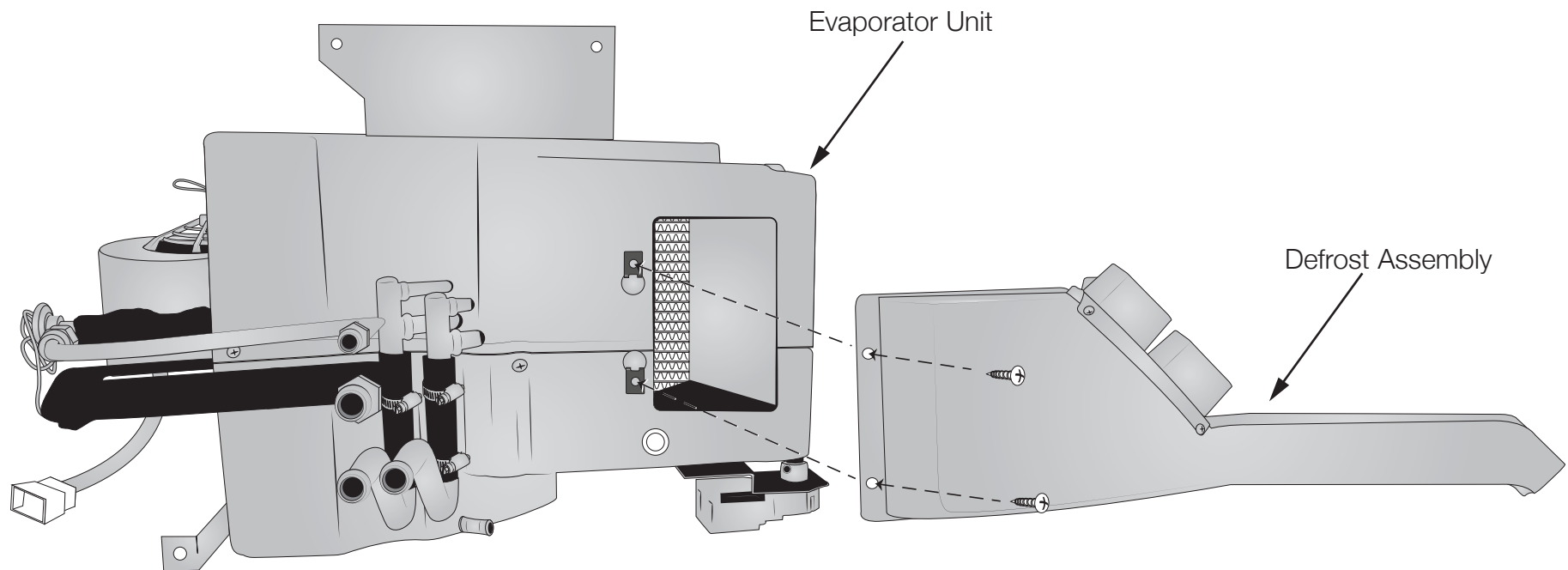

Note: The Defrost adapter will have slight movement until it is installed, pressure of installation will make it stable.

Pre-installed Face Duct Assembly

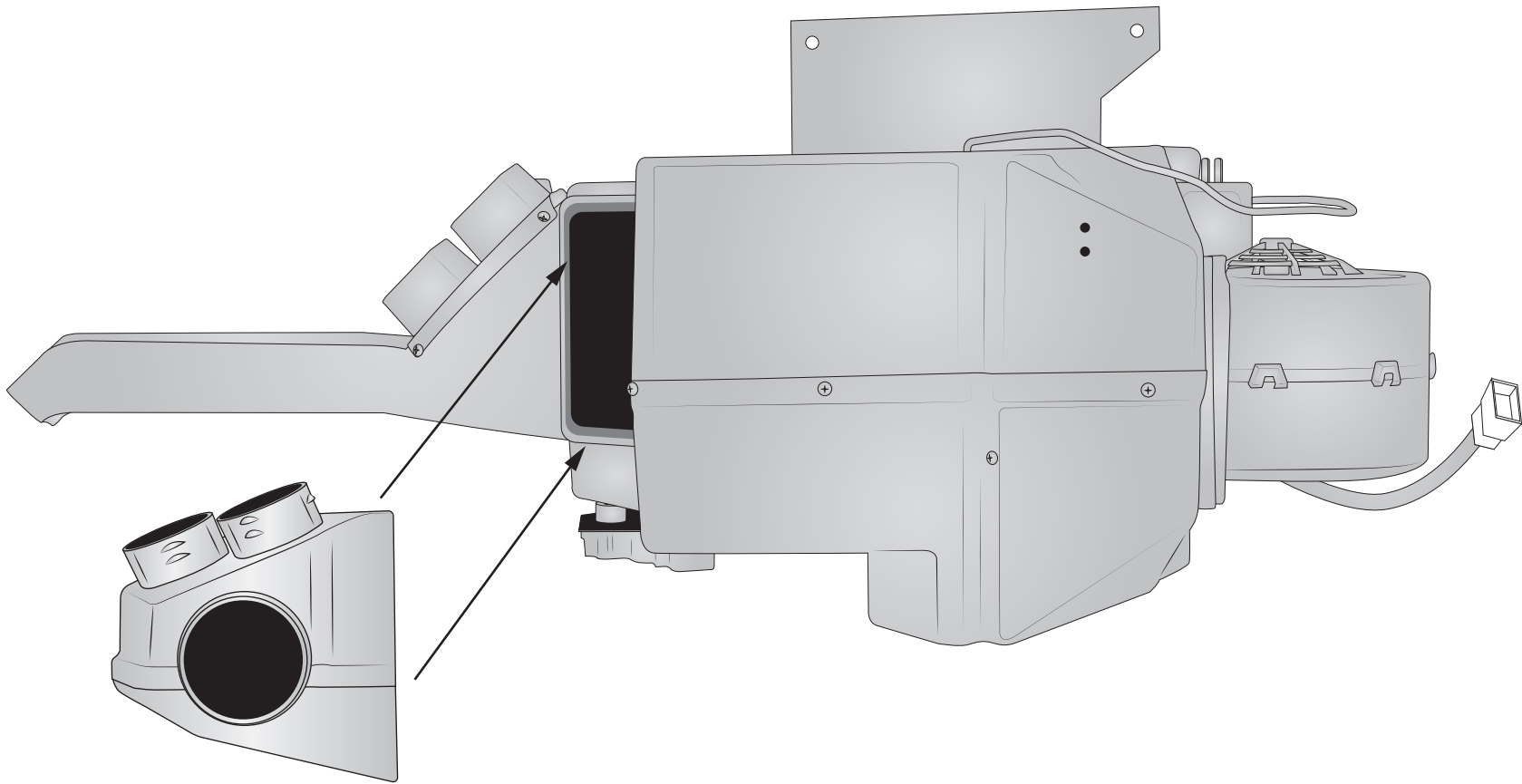

Take a minute to familiarize yourself with the evaporator unit:

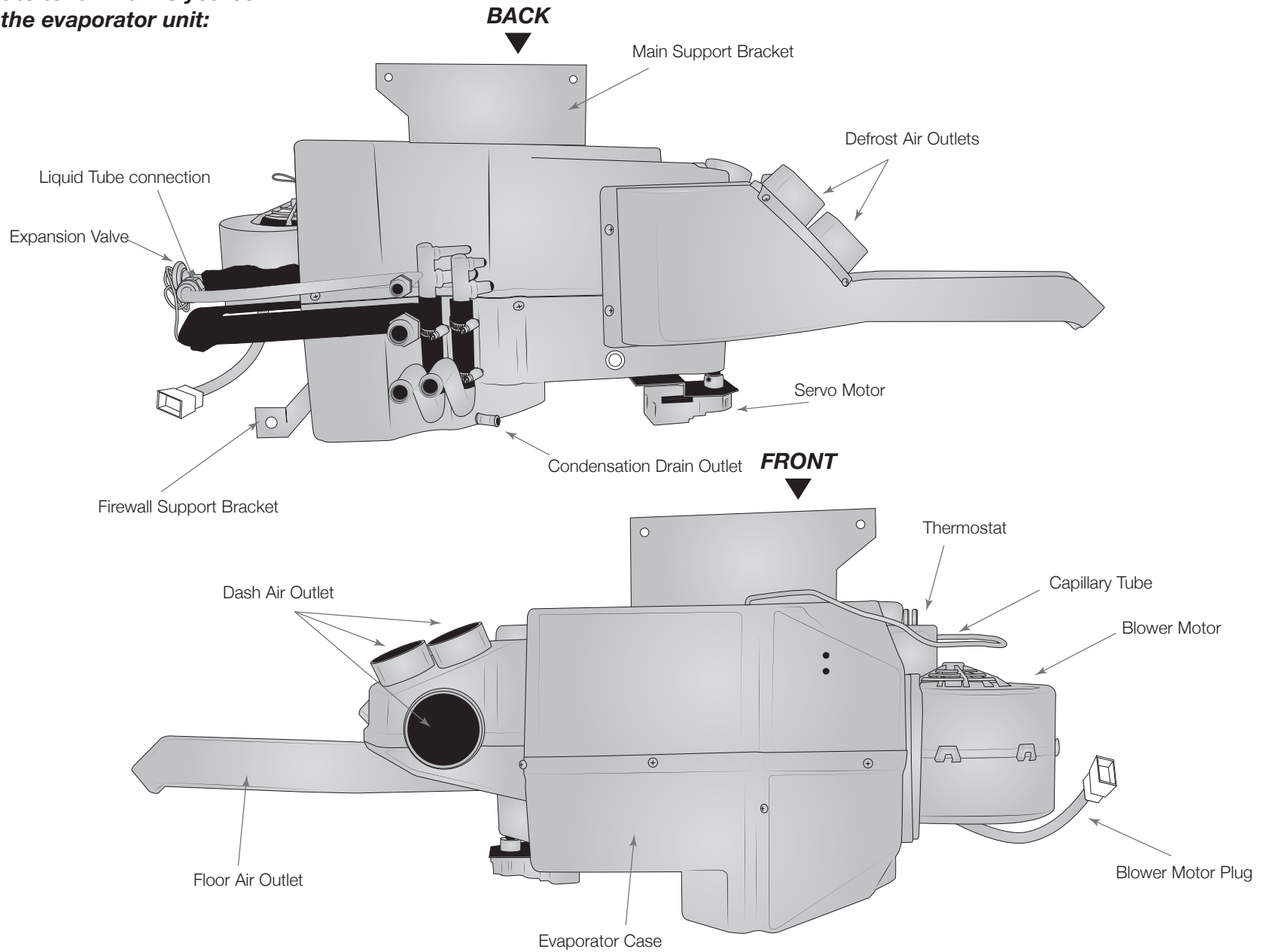

WIRING PREP

• Items Needed for Bench Calibration

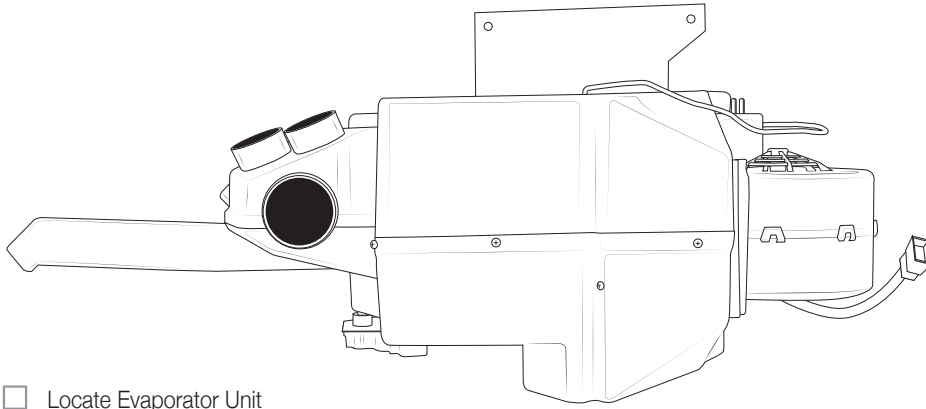

Locate Evaporator Unit

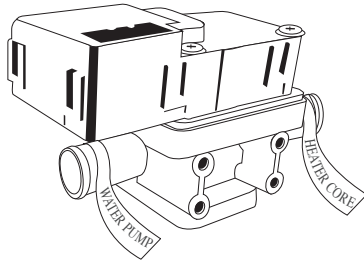

Locate electronic water valve from Bag Kit D

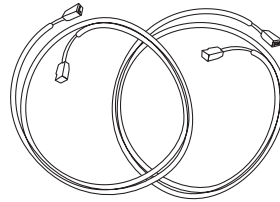

Locate Yellow, Orange wiring harness from Bag Kit C

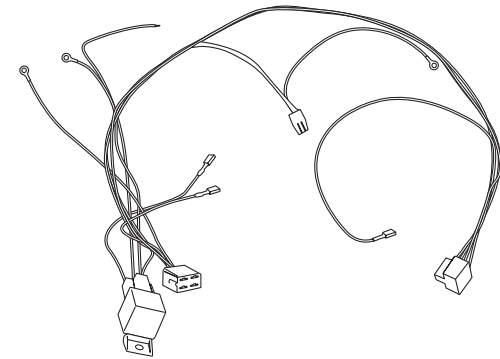

Locate main wiring harness from Bag Kit C

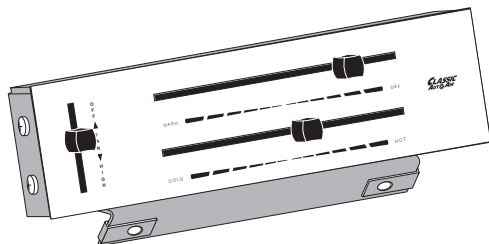

Locate the D.E.R. control in the CONTROL BOX

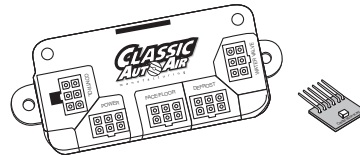

Locate ECU and Calibration Key from Bag Kit C
DO NOT USE CALIBRATION KEY WITHOUT TECH SUPPORT

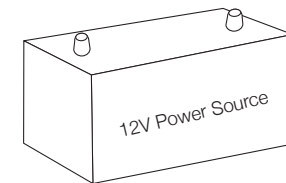

Acquire a 12V Battery (NOT a battery charger)

WIRING PREP

• Wiring Preparation Steps 1 and 2

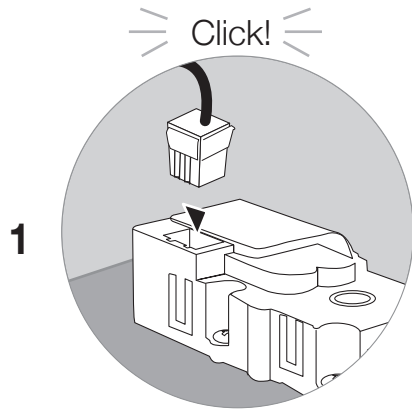

Connect Yellow Harness into Face/Floor Servo Motor

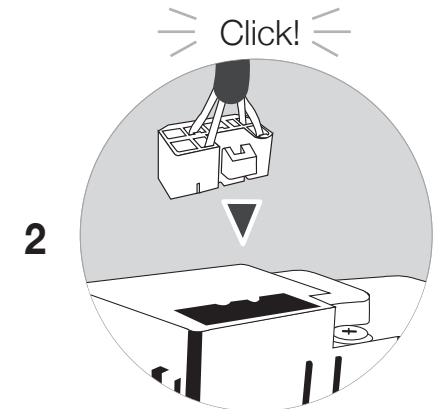

Connect Orange Harness into water valve

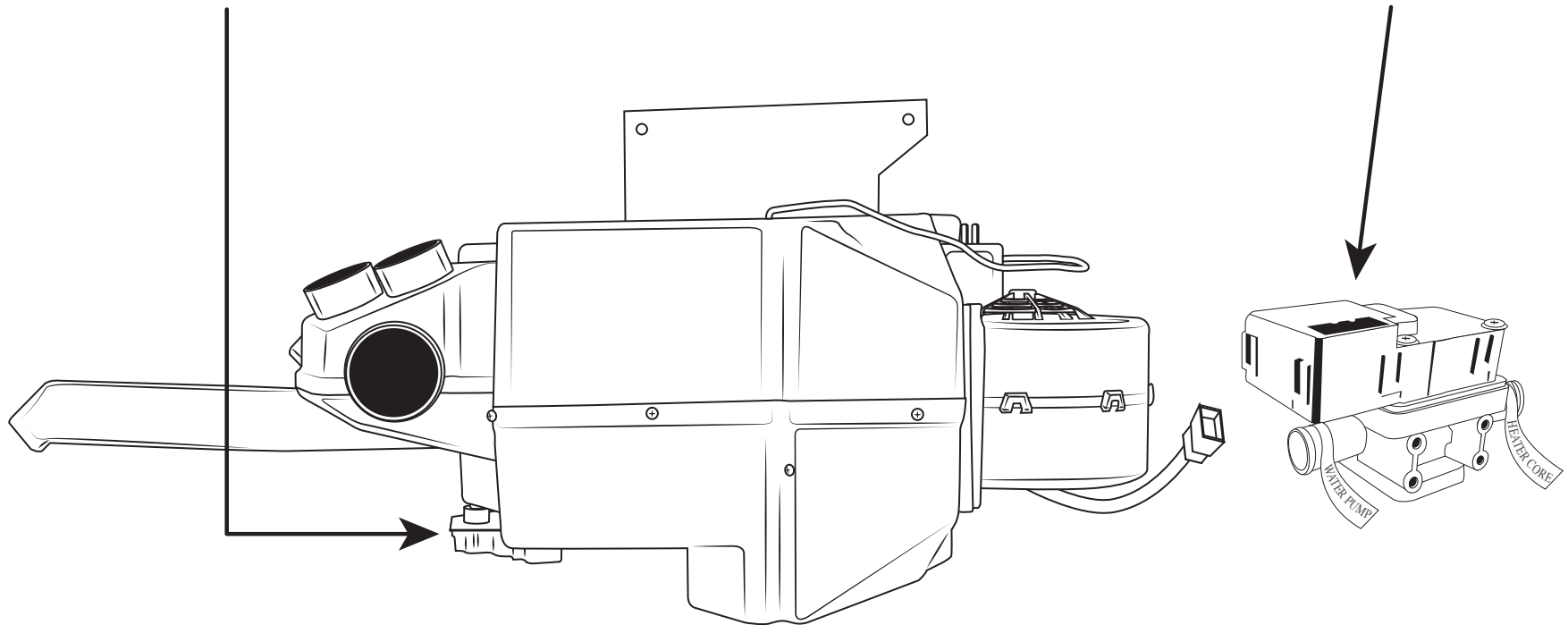

WIRING PREP

• Wiring Preparation Steps 3 thru 5

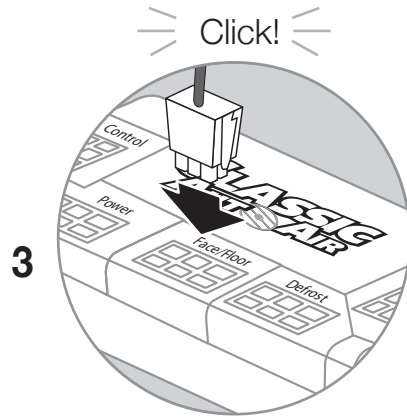

3 Connect Yellow Harness into Face/Floor Port on ECU

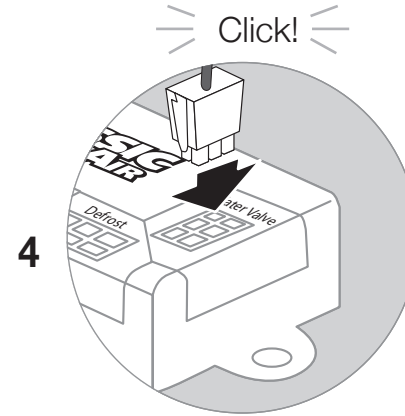

4 Connect Orange Harness into Water Valve Port on ECU

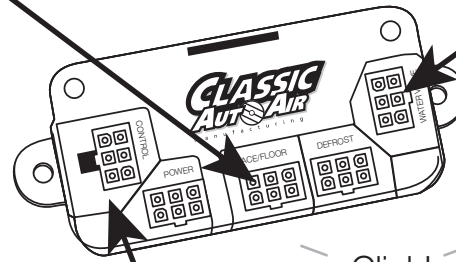

5 From your D.E.R.,
Connect Green Harness into
Control Port on ECU

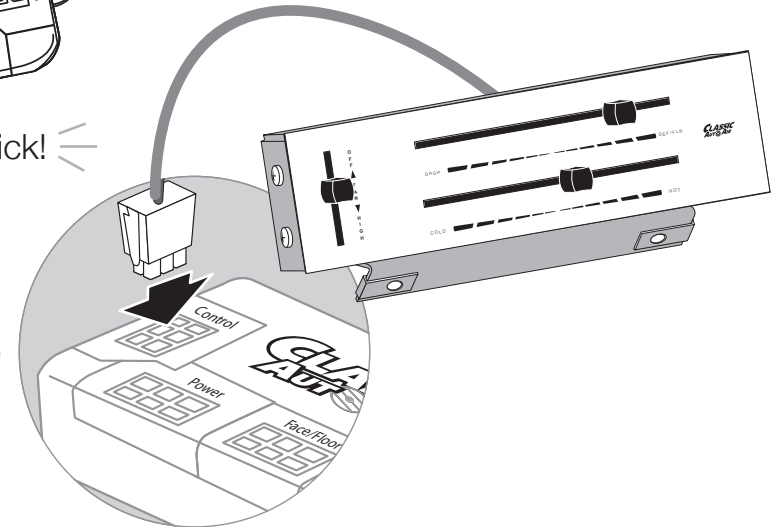

WIRING PREP

• Wiring Preparation Steps 6 through 11

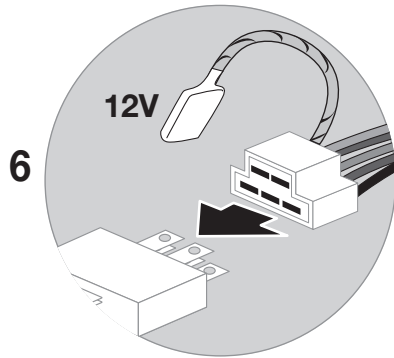

6
Connect corresponding fan switch harness to the blower switch on controls connect power lead to 12V.

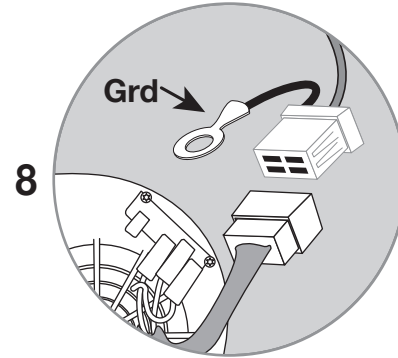

8
Connect corresponding fan motor harness. Connect ground.

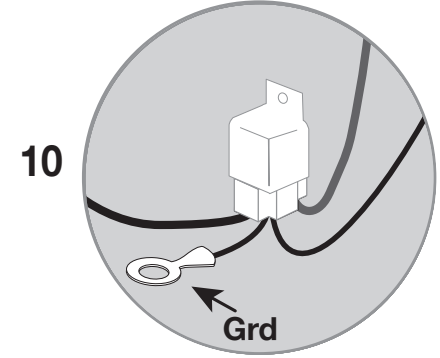

10
Connect ground.

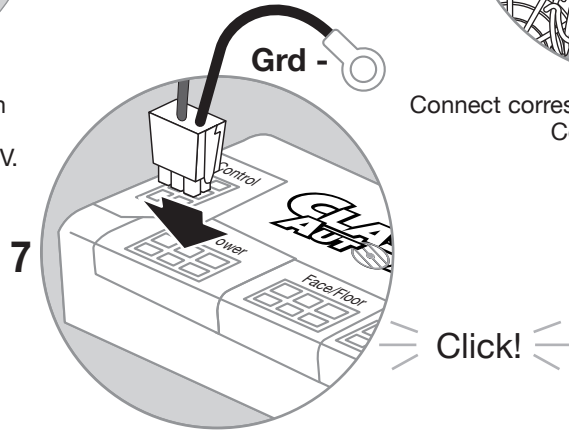

7
Connect red tagged power harness to POWER port on ECU. Connect ground.

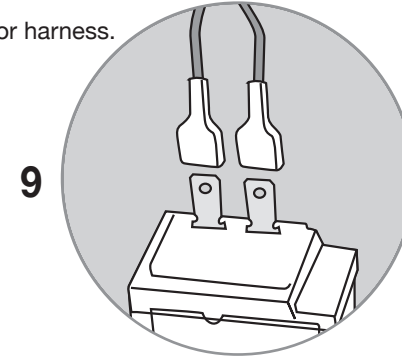

9
Connect both BLUE leads into thermostat (either lead into either terminal)

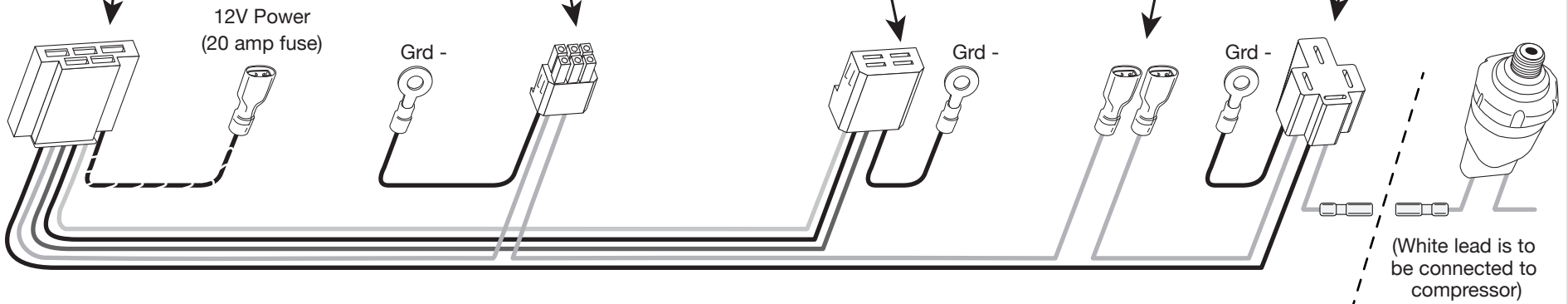

FUNCTION TESTING

• Function Test, Steps 1 thru 3

1

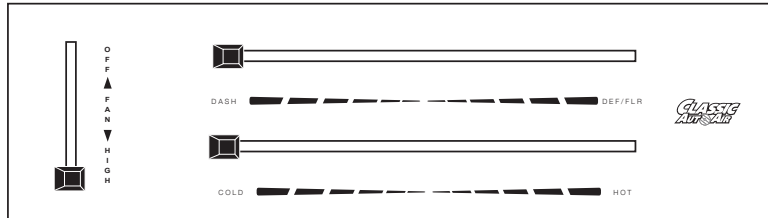

Move FAN knob to HIGH
Move MODE knob to DASH
Move TEMP knob to COLD



AIR OUT OF DASH VENTS



2

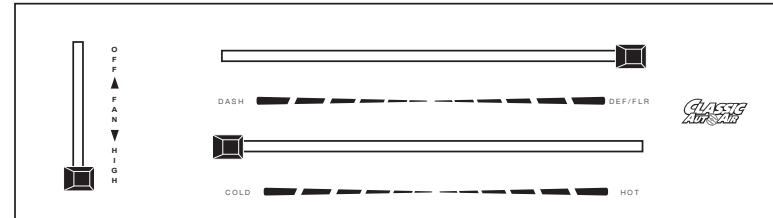

Move MODE knob to DEFROST/FLOOR



AIR OUT OF DEFROST/FLOOR VENTS

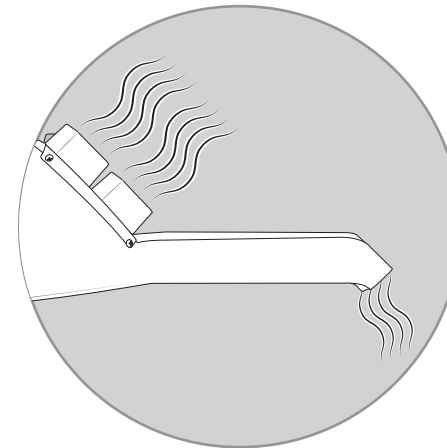

FUNCTION TESTING

• Function Test, Steps 4 and 5

4

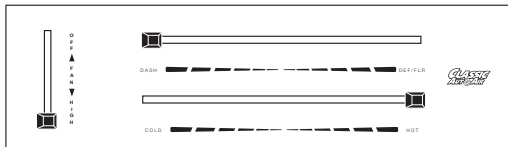

Move TEMP knob to HOT

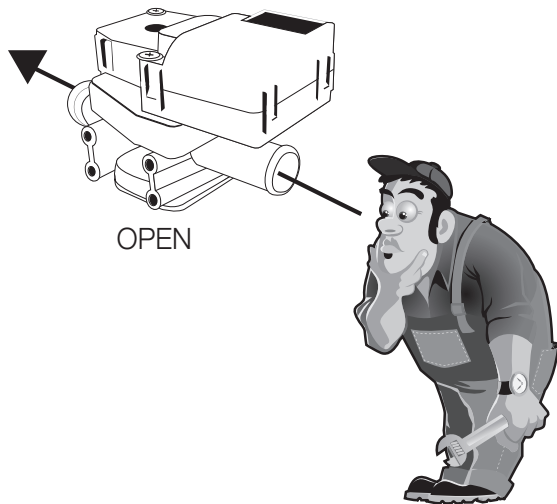

You will be able to see through water valve passage

5



Move TEMP knob to COLD

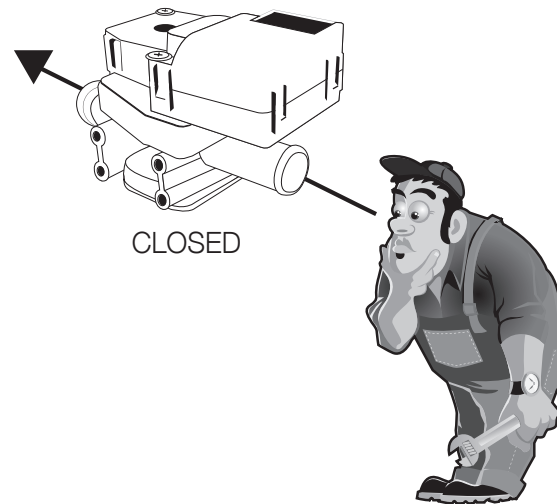

You will NOT be able to see through water valve passage

Return all wiring harnesses, water valve, and ECU to their originally bags/boxes (this keeps them organized for future installation steps).

Your controls are now fully calibrated to your unit. Please refer to the next steps in your installation manual for installing the system in your vehicle.

NOTE: IF DURING ANY OF THESE STEPS YOU DO NOT GET THE CORRECT OUTCOME, PLEASE CALL TECH SUPPORT BEFORE INSTALLING INTO VEHICLE.
1(866)435-7801

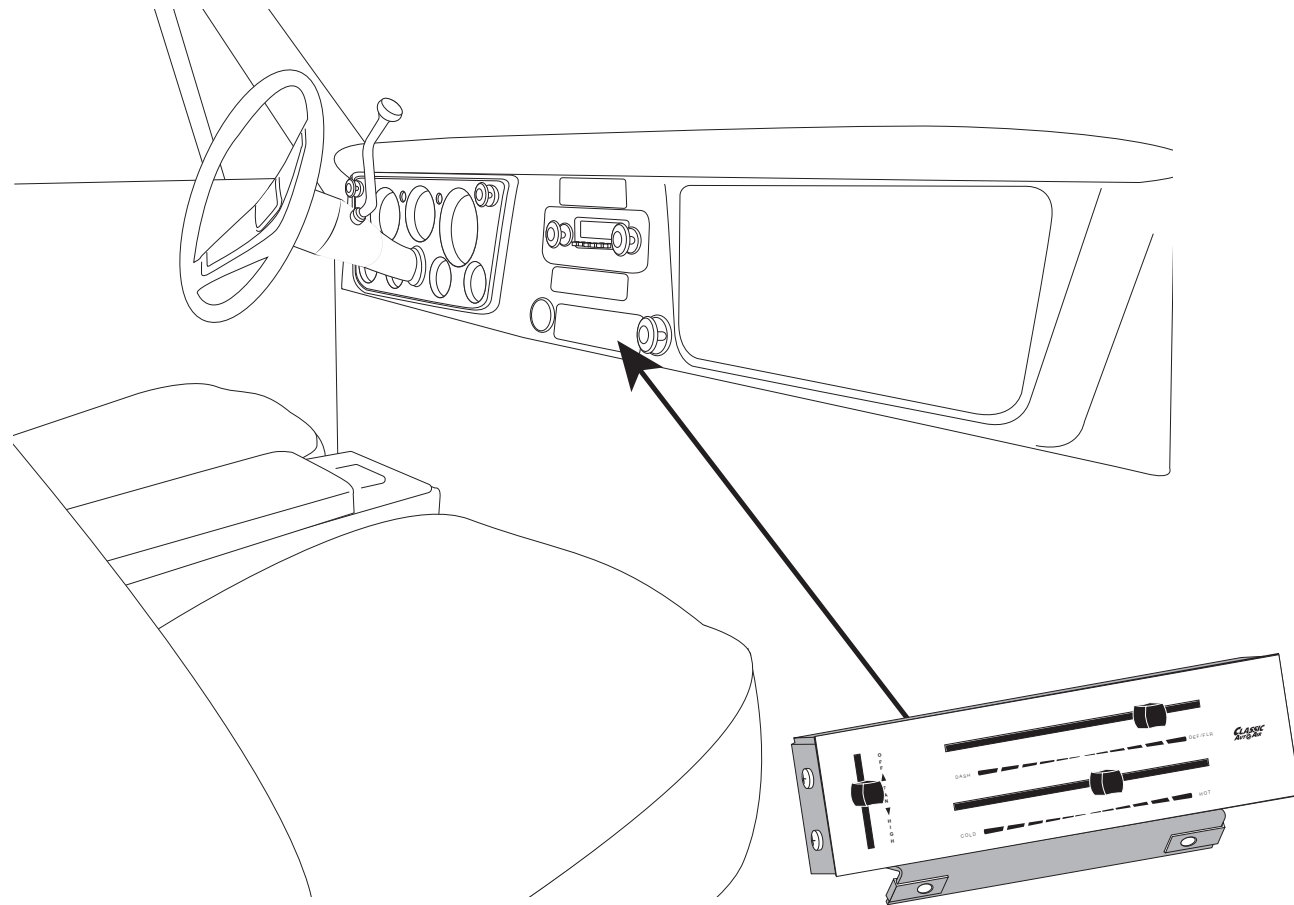

Install D.E.R. at this time using original mounting hardware.

NOTE: Two people are needed for this step!

Place evaporator on floor panel. Roll unit up behind the glove box opening, inserting tubes thru the holes in the firewall block off plate.

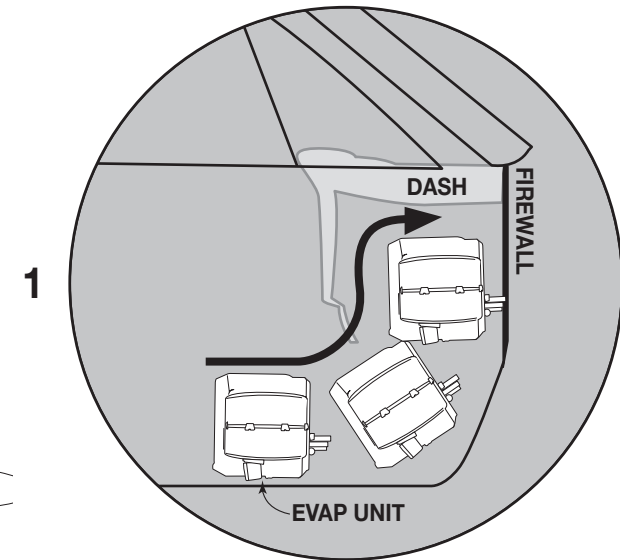
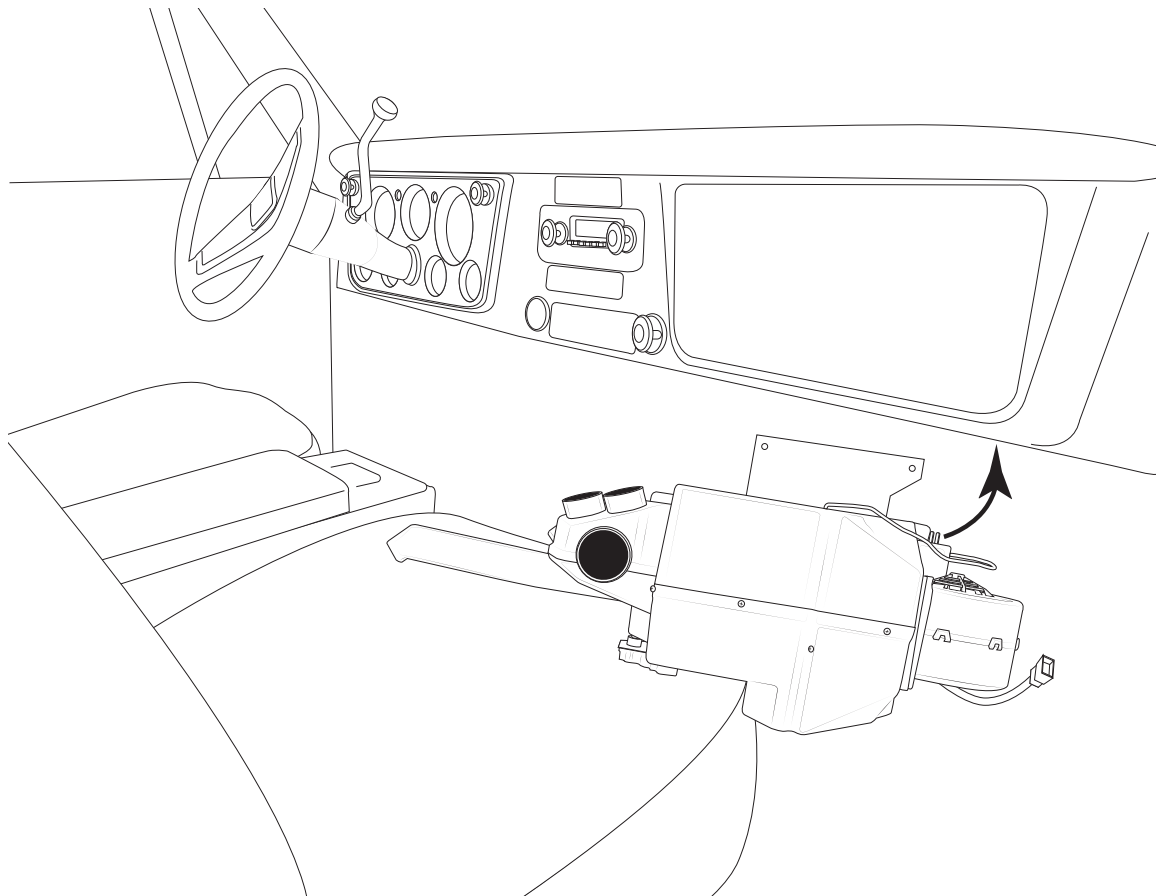

Installing the evaporator will require attention and detail. The tubes will need to be inserted through the block off plate

FIGURE 17

- 1 Locate the unit and slide in behind glovebox opening and the firewall. Insert the hookup tubes through the firewall block off. This will require some finesse.

Holding the unit in a level position, and using the tubes to locate the unit side to side.

NOTE: Two people are needed for this step!

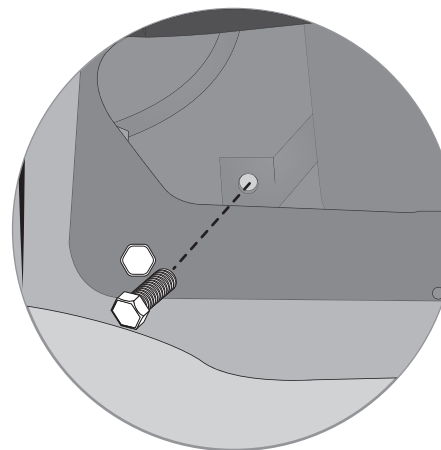
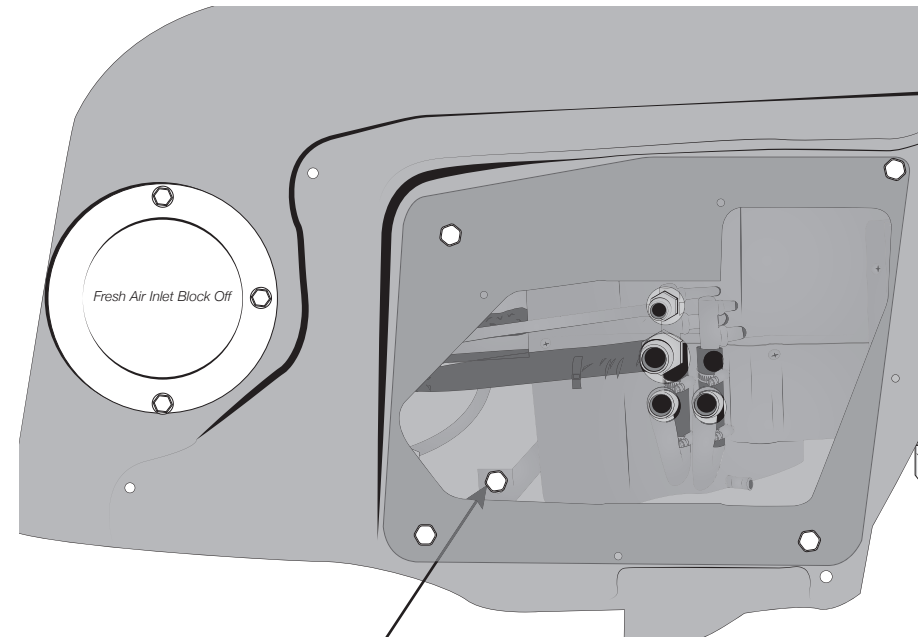

Using the last 1/4 - #20 x 5/8" bolt and Flanged nut provided in Bag Kit B Attach evaporator bracket to firewall block off plate.

LEAVE LOOSE AT THIS TIME.

NOTE: Two people are needed for this step!

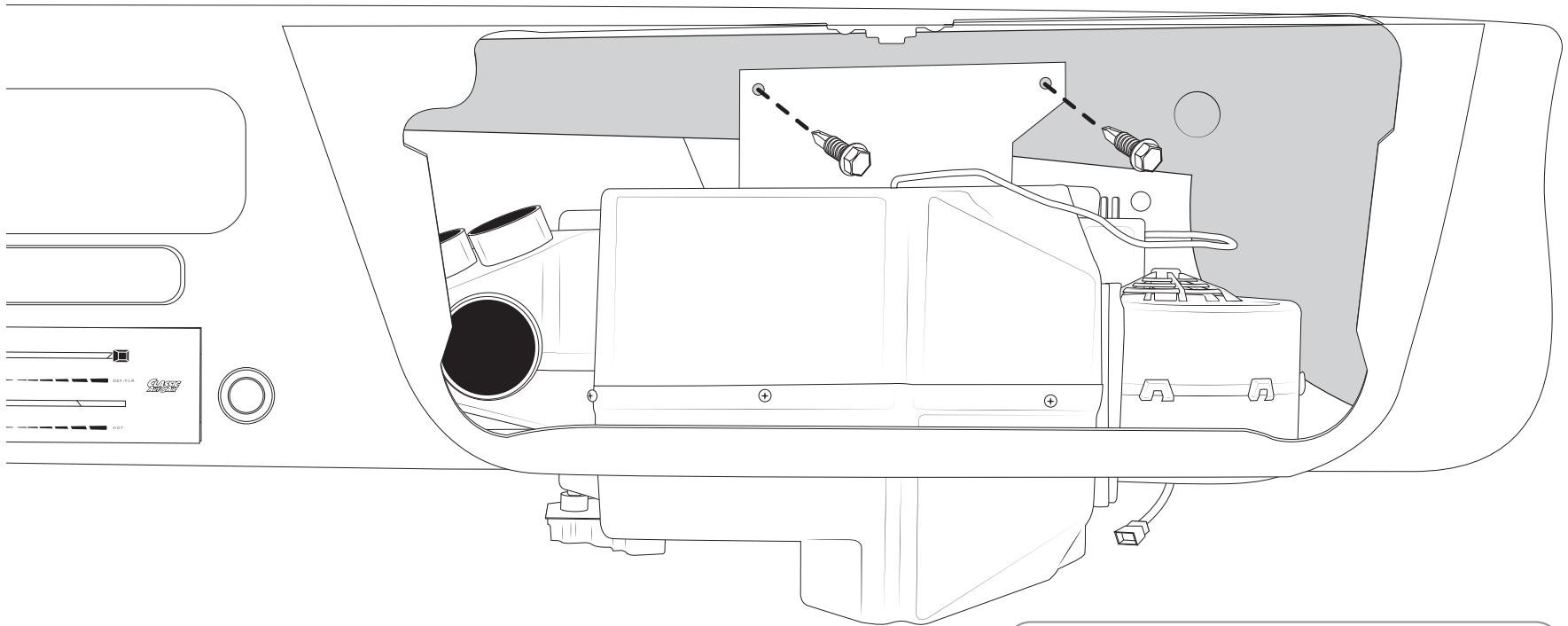

- 2** Attach through top unit support into the fresh air duct behind the glove box opening. Use Two #14 - 16 x 3/4" Tek Screws from Bag Kit B.

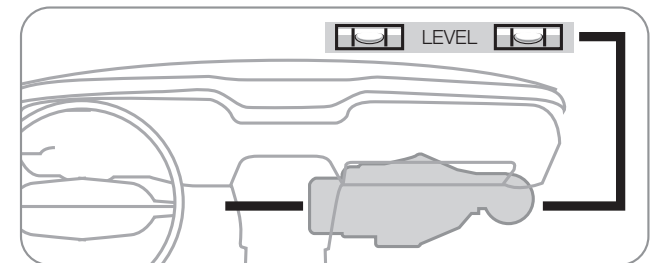

TECH TIPS

Be sure to align the evaporator unit level with the bottom of dash as shown above, with a small degree of tilt toward the back to allow proper drain of condensation.

NOTE: Two people are needed for this step!

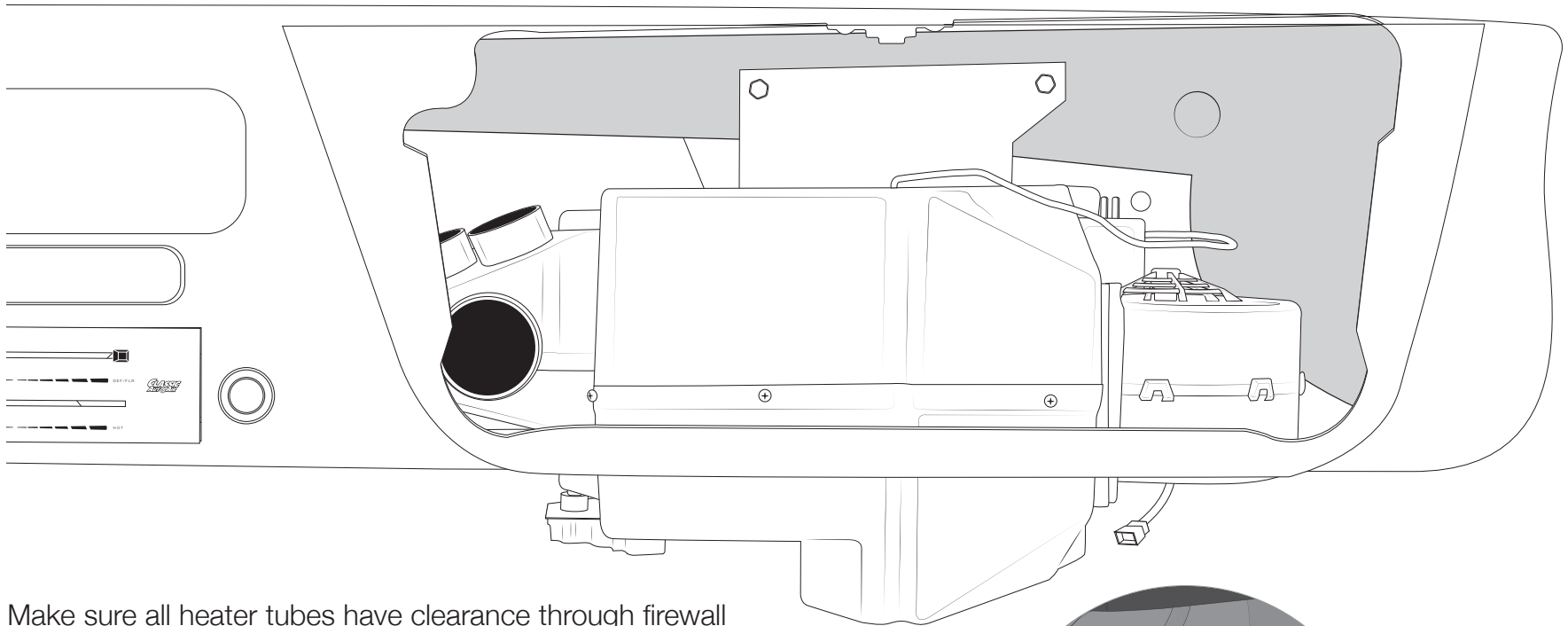

- 3** Make sure all heater tubes have clearance through firewall and thermostat on evaporator and expansion valve are not pressed against the cowl before you tighten all bolts.

- 4** Now tighten the last 1/4 - #20 x 5/8" bolt on the firewall block off plate.

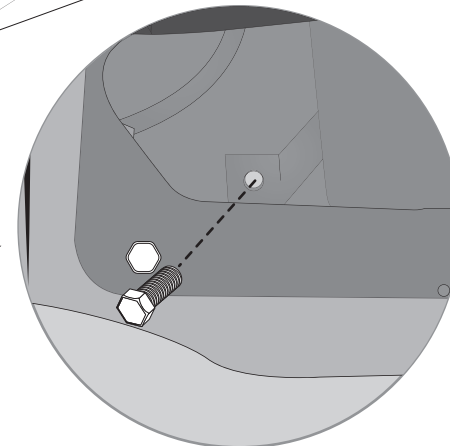

THESE ARE THE PARTS YOU WILL FIND IN BAG KIT C

You will use all of these parts and hardware during the next series of installation steps.

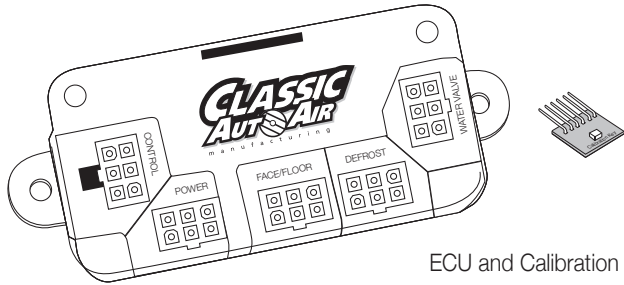

ECU and Calibration Key

DO NOT USE CALIBRATION KEY WITHOUT TECH SUPPORT

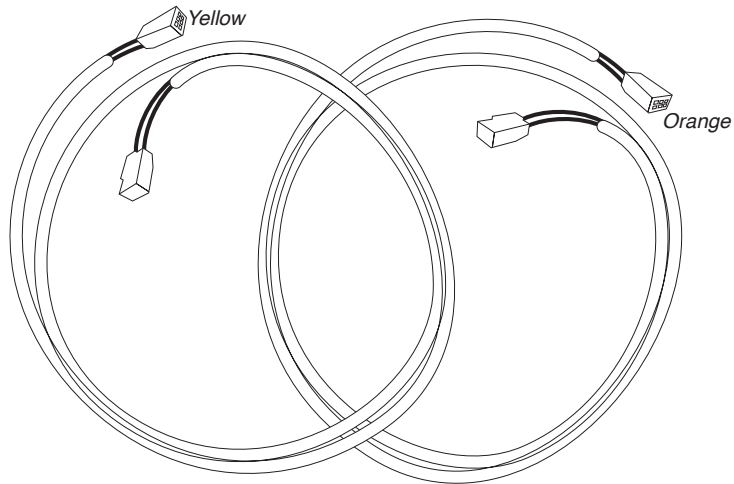

Wire Harness System
EZ

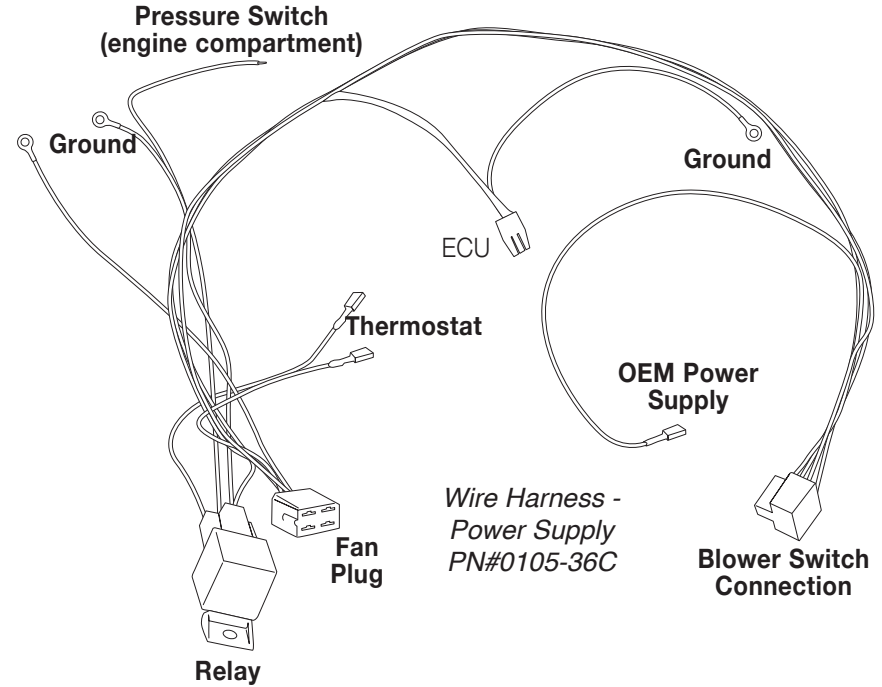

Wire Harness - Power Supply
PN#0105-36C

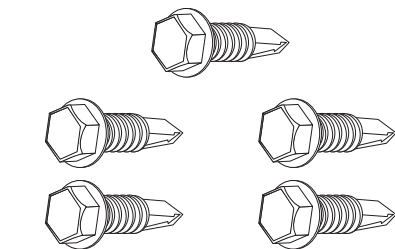

Five #10 - 16 x 3/4" Tek Screws

Illustrations NOT shown actual size

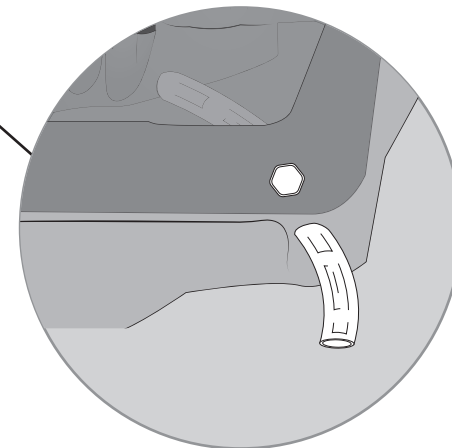
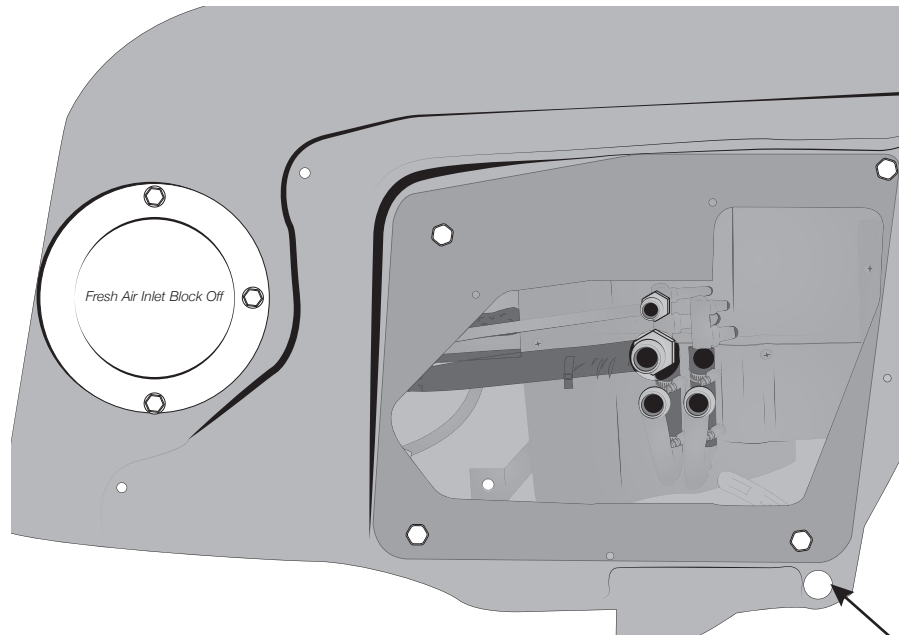

Feed Drain tube that is Bag Kit C though the 11/16" hole you drilled earlier.

IMPORTANT NOTICE: PROPER INSTALLATION OF WATER VALVE

Your water valve MUST be installed per these instructions!... (If not, your system will not work properly.)

The **lower** heater tube connection on firewall will be routed to the water connection on intake manifold using 5/8" dia. heater hose with the supplied worm gear clamp.

The **upper** heater tube connection on the firewall will be routed to the water valve connection labeled **heater core**, using a 6" piece of 5/8" heater hose attached with supplied worm gear clamp.

Connect the remaining outlet on water valve labeled **water pump** to the water pump using 5/8" dia. heater hose with the supplied worm gear clamp.

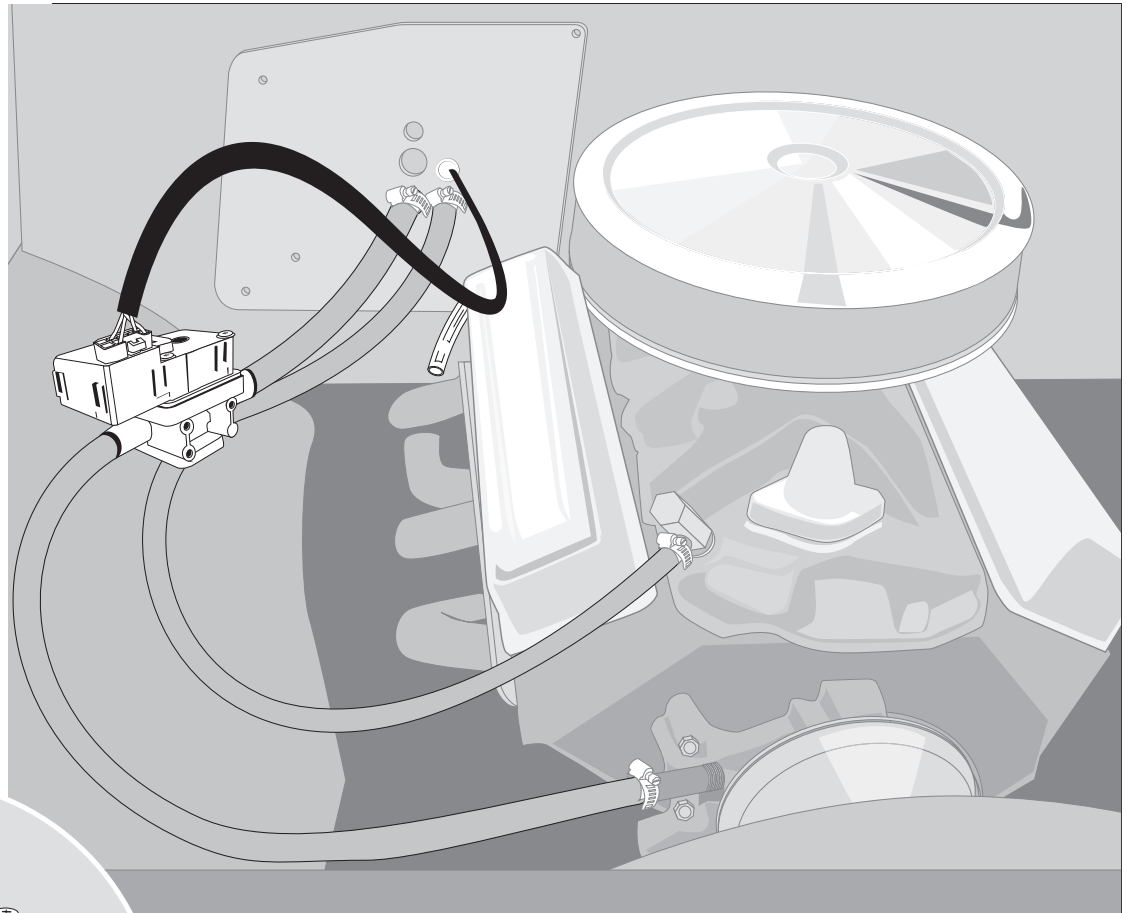

**FOLLOW THESE
TAGS... CHECK IT
TWICE BEFORE
PROCEEDING!**

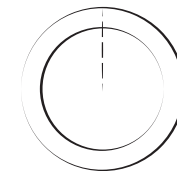
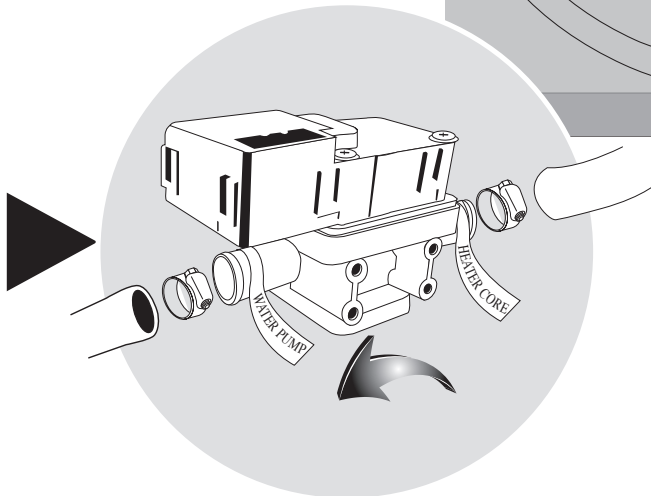

Make a slit (cut) in the 3/4" cap plug,
then feed harness through.

THESE ARE THE PARTS YOU WILL FIND IN BAG KIT D

You will use all of these parts and hardware during the next series of installation steps.

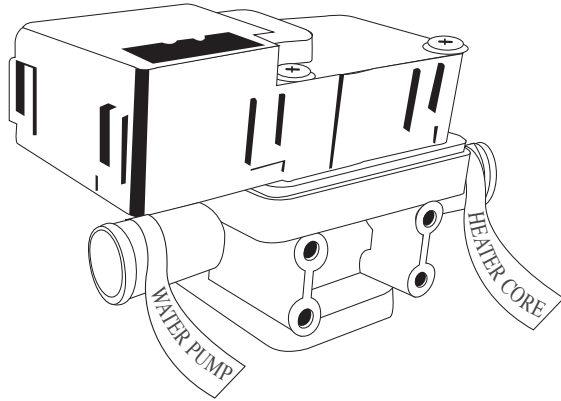

Electronic Water Control Valve
PN#16-1081-2



Clear Plastic Drain Tube

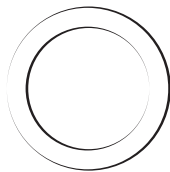

Cap Plug



Refrigerant Tape

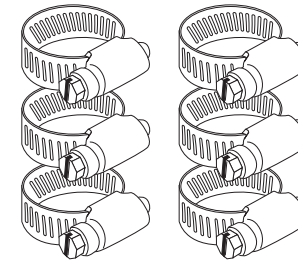

Six Worm Gear Clamps

Illustrations NOT shown actual size

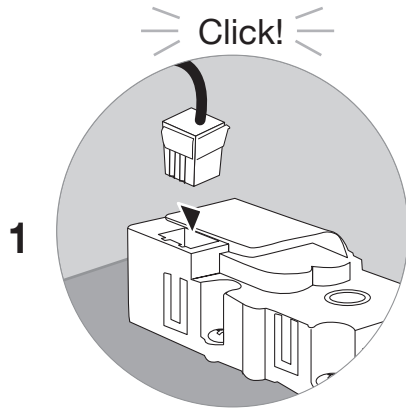

Connect blue harness into Defrost/Heat servo motor

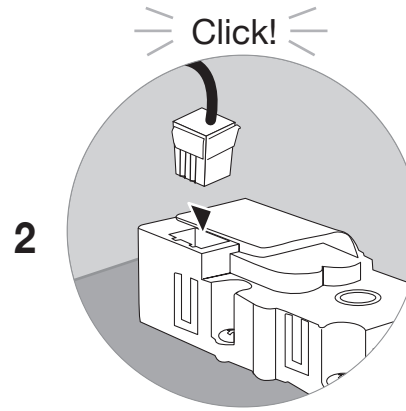

Connect yellow harness into Face/Floor servo motor

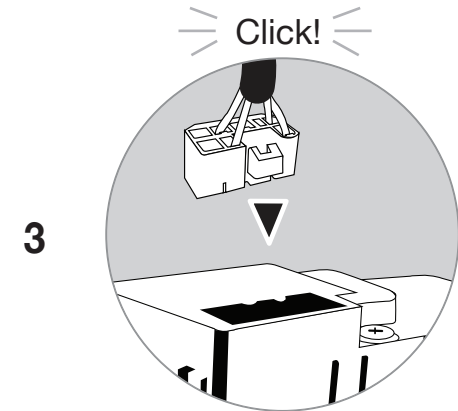

Connect orange harness into water valve

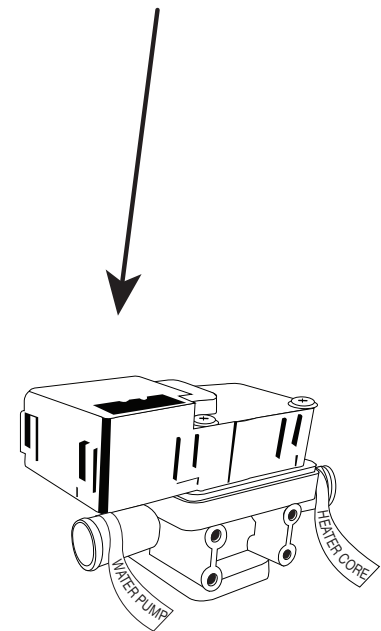
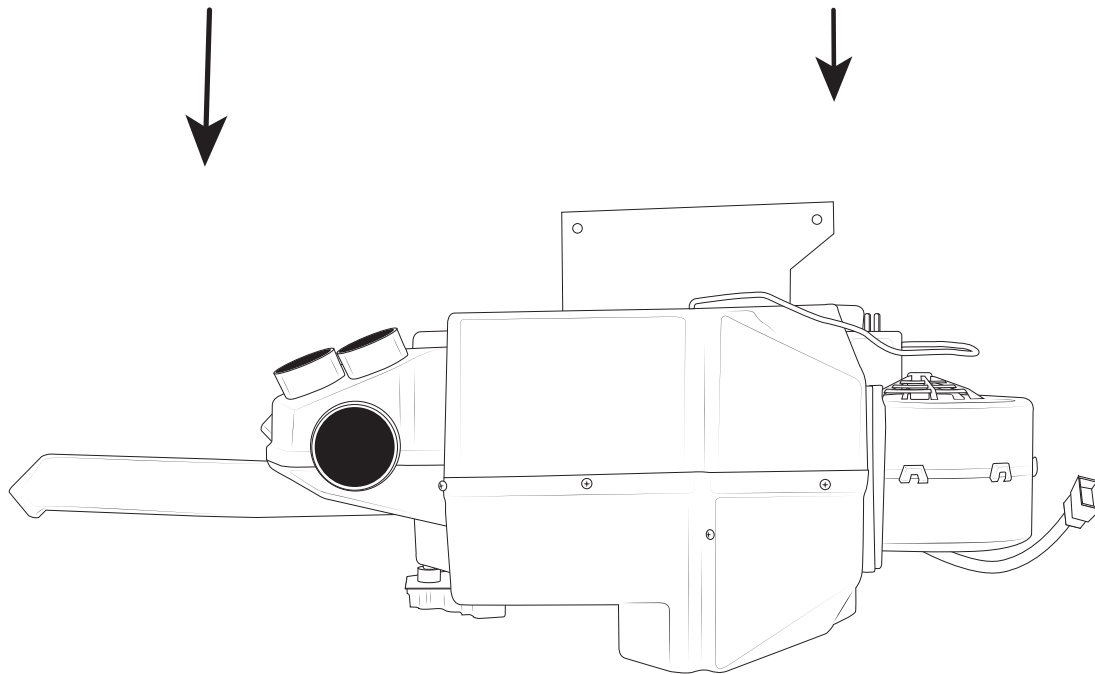

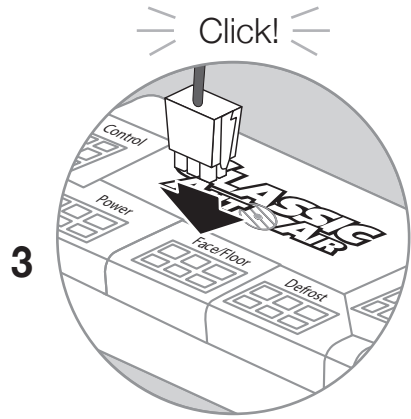

Plug Yellow Harness into Face/Floor Port on ECU

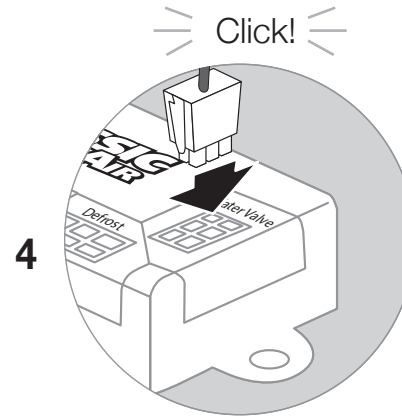

Plug Orange Harness into Water Valve Port on ECU

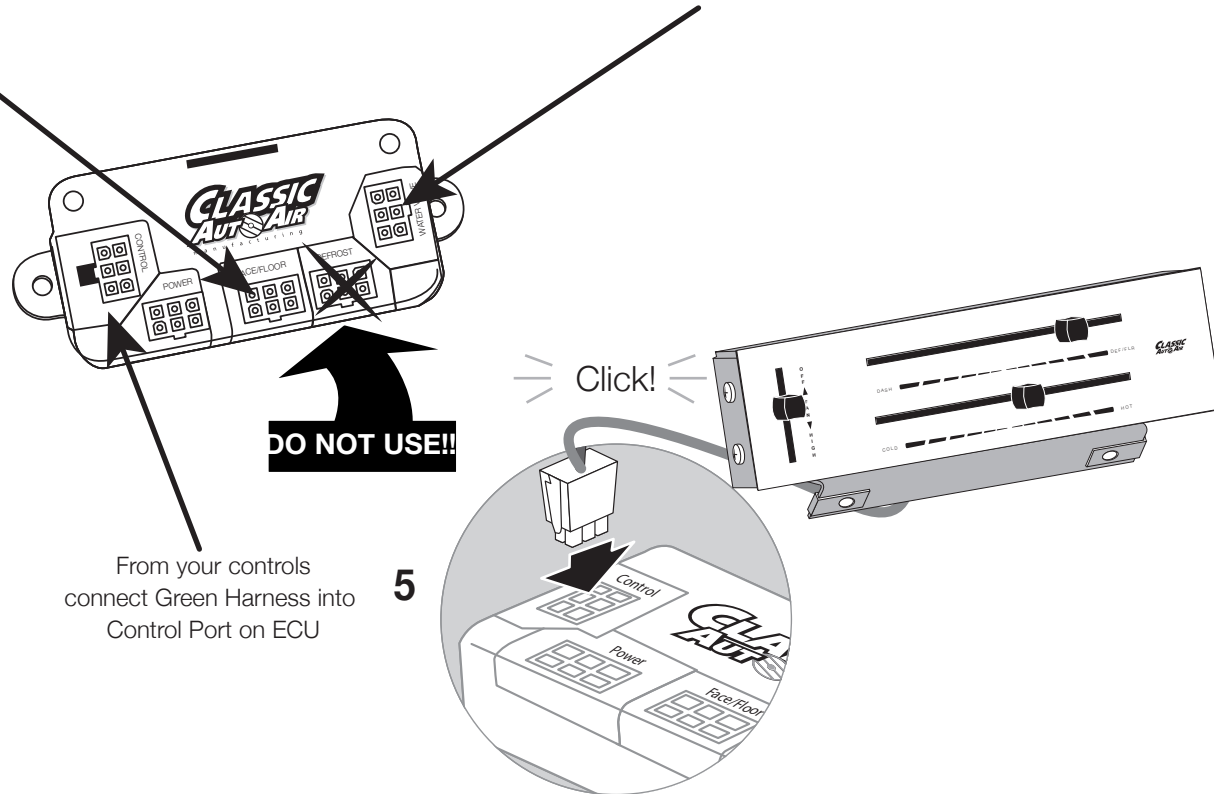

From your controls connect Green Harness into Control Port on ECU

5

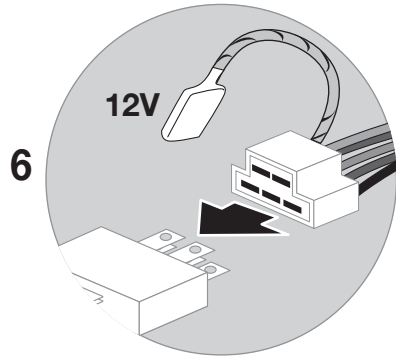

Connect corresponding fan switch harness to the blower switch on controls connect power lead to 12V.

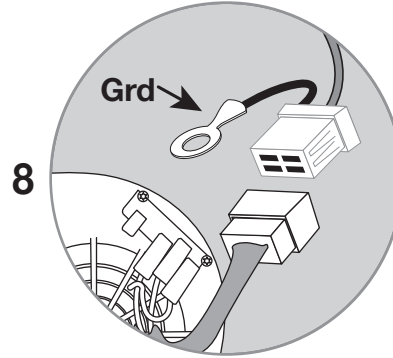

Connect corresponding fan motor harness. Connect ground.

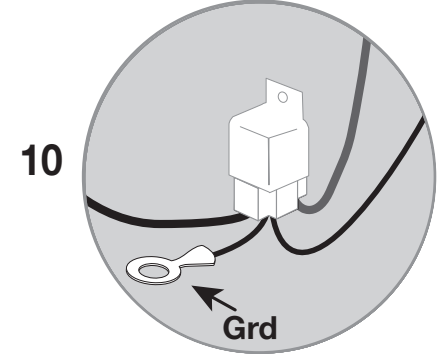

Connect ground.

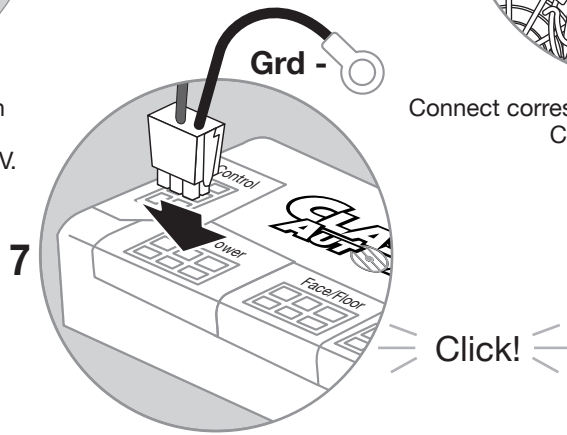

Connect red tagged power harness to POWER port on ECU. Connect ground.

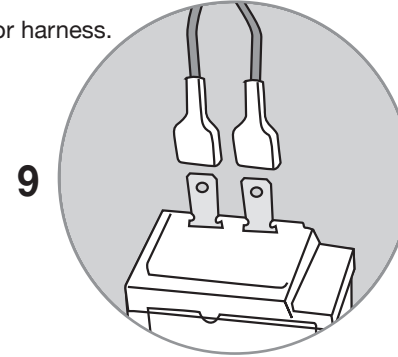

Connect both BLUE leads into thermostat (either lead into either terminal)

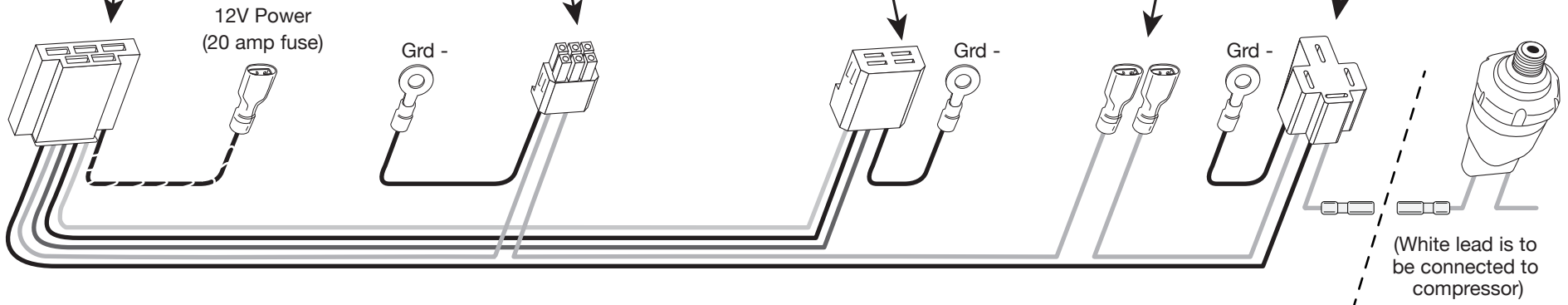

THESE ARE THE PARTS YOU WILL FIND IN BAG KITS E, F, and G

You will use all of these parts and hardware during the next series of installation steps.

Bag E

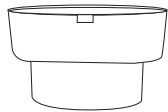

Passenger Defrost Adapter
PN# 2-1033-2

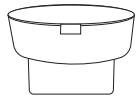

Driver Defrost Adapter
PN# 1-2015-3

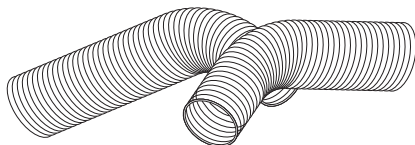

Two Duct Hoses, 2" I.D.

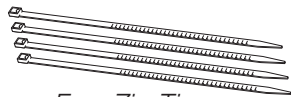

Four Zip-Ties

Bag F

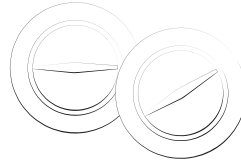

Two Louver, Ball, Chrome / 2" HA
PN# 06-2006-11-8

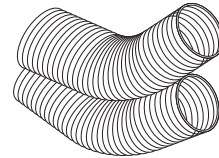

Two Duct Hoses, 2" I.D.

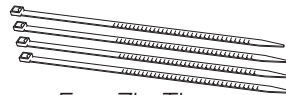

Four Zip-Ties



Two Astro Louver, Ball, Chrome
Upgrade Option

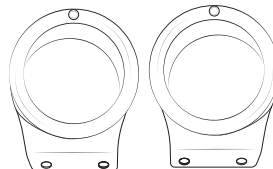

Two Astro Ball Housing
PN# 2-0210
Upgrade Option

Bag G

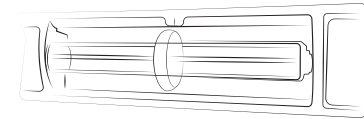

Louver, Center, OEM
PN# 67-7000592



Hose, Adapter, Center
PN# 0020-35



Two 1/4-20 x 5/8" Phillips Screws

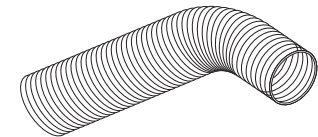

One Duct Hoses, 2.5" I.D.



Two Zip-Ties

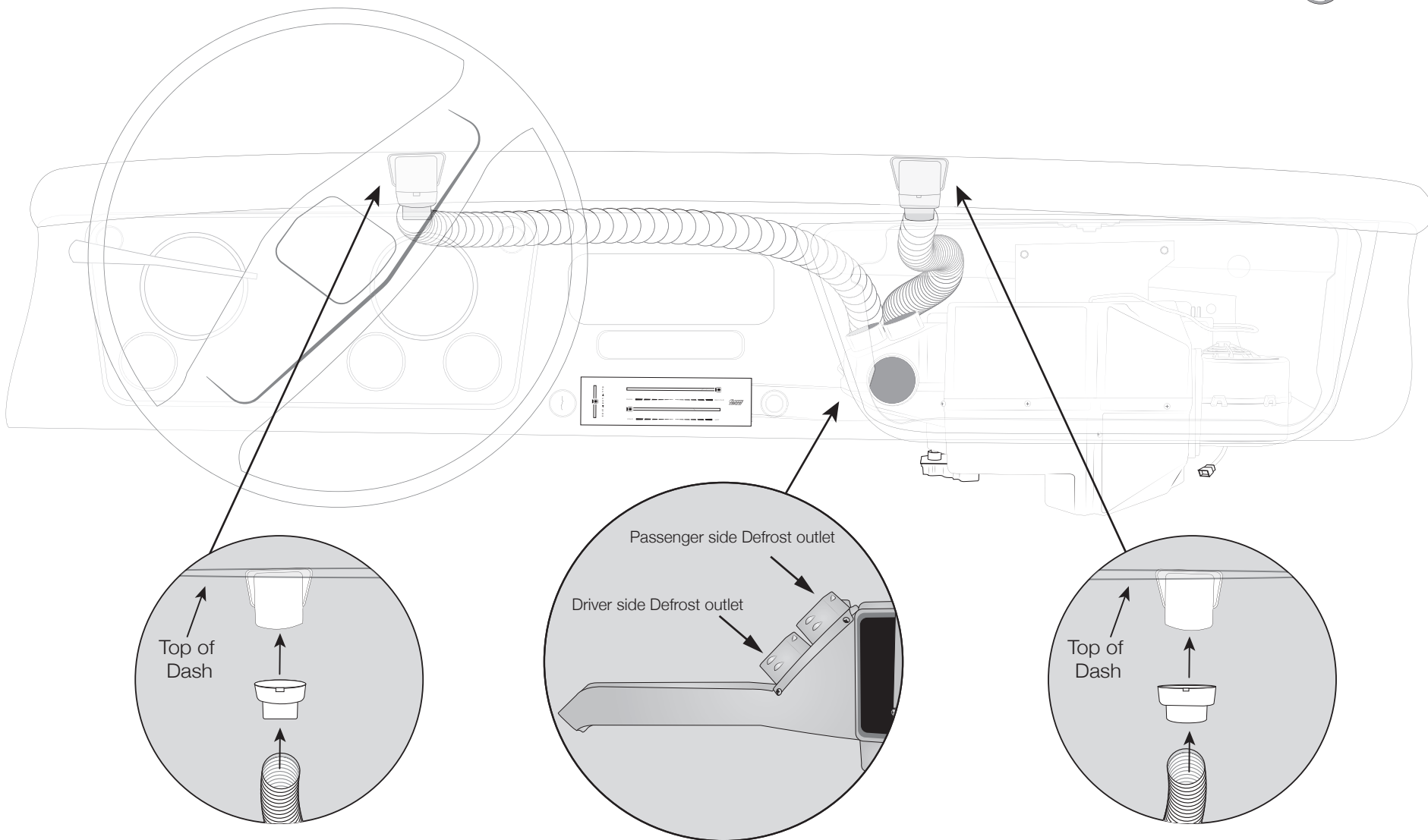

Attach driver side defrost adapter to the factory driver side defrost vent. Attach hose from defrost vent on evaporator to the adapter at this time. Secure with Zip-tie. **Note Driver's side adapter is round.**



The smoother the route of the flex hoses the better the airflow.

Attach passenger side defrost adapter to the factory passenger side defrost vent. Attach hose from defrost vent on evaporator to the adapter at this time. Secure with Zip-tie. **Note passenger's side adapter is oval.**

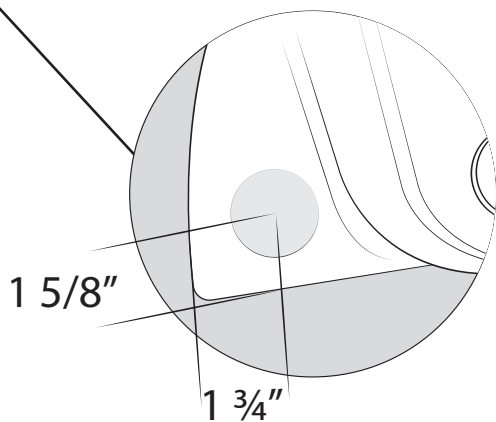
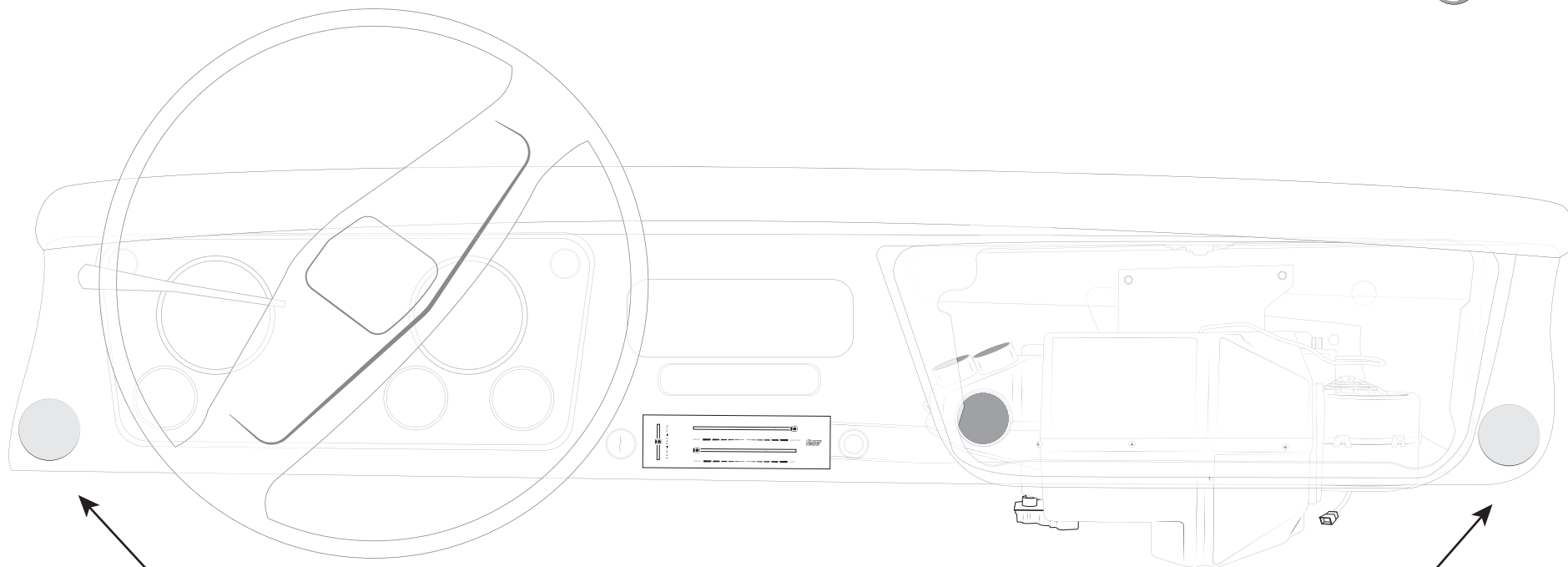

On drivers side of instrument panel.
Using a 2 1/4" dia hole saw locate and drill a hole as shown.

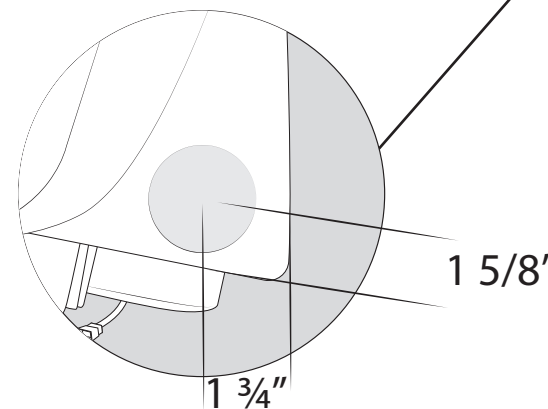

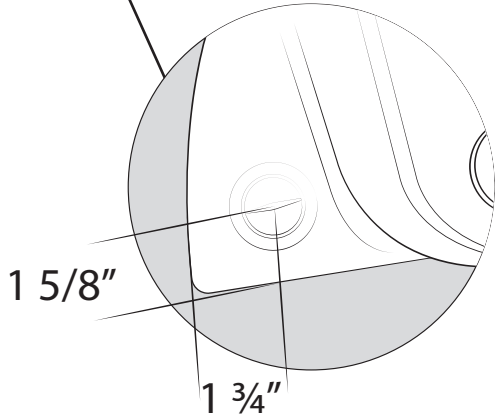
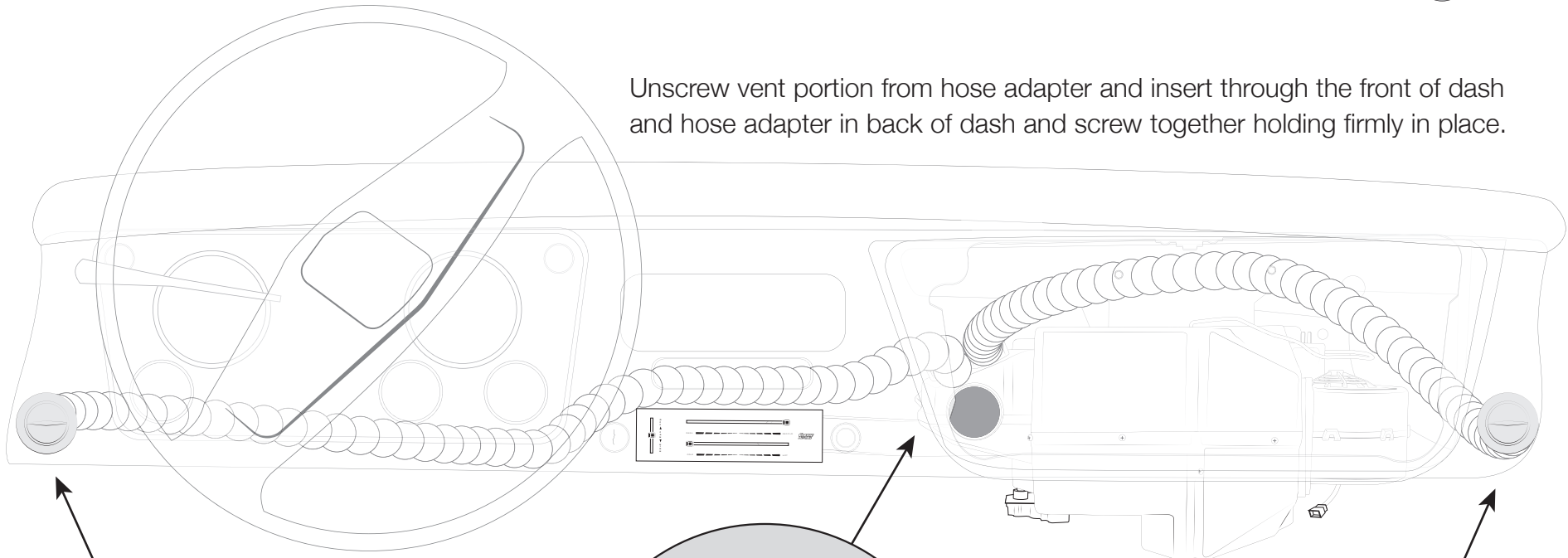

On the passenger side of next to glove box.
Using a 2 1/4" dia. hole saw locate and cut a hole as shown.

Unscrew vent portion from hose adapter and insert through the front of dash and hose adapter in back of dash and screw together holding firmly in place.

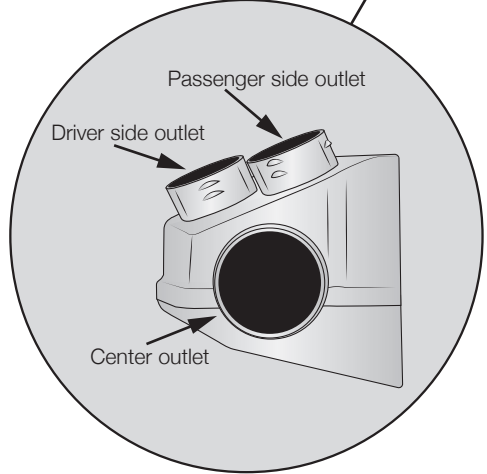

Locate 2" dia. Ball Louver with the 2" dia hose adapter. And install in the hole previously cut. Route duct hose as shown and secure with zip ties.



 The smoother the route of the flex hoses the better the airflow.

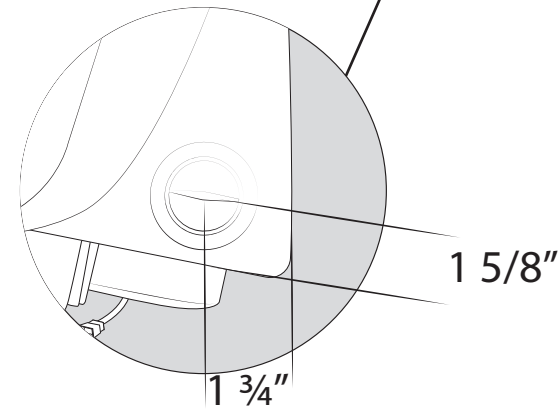

Locate a 2" dia. Ball Louver with 2" dia hose adapter. And install in the hole previously cut. Route duct hose as shown and secure with zip ties.

Caution: The opening is very critical. It must be ruff cut and then filed to the desired size. The louver must barely fit through the opening.

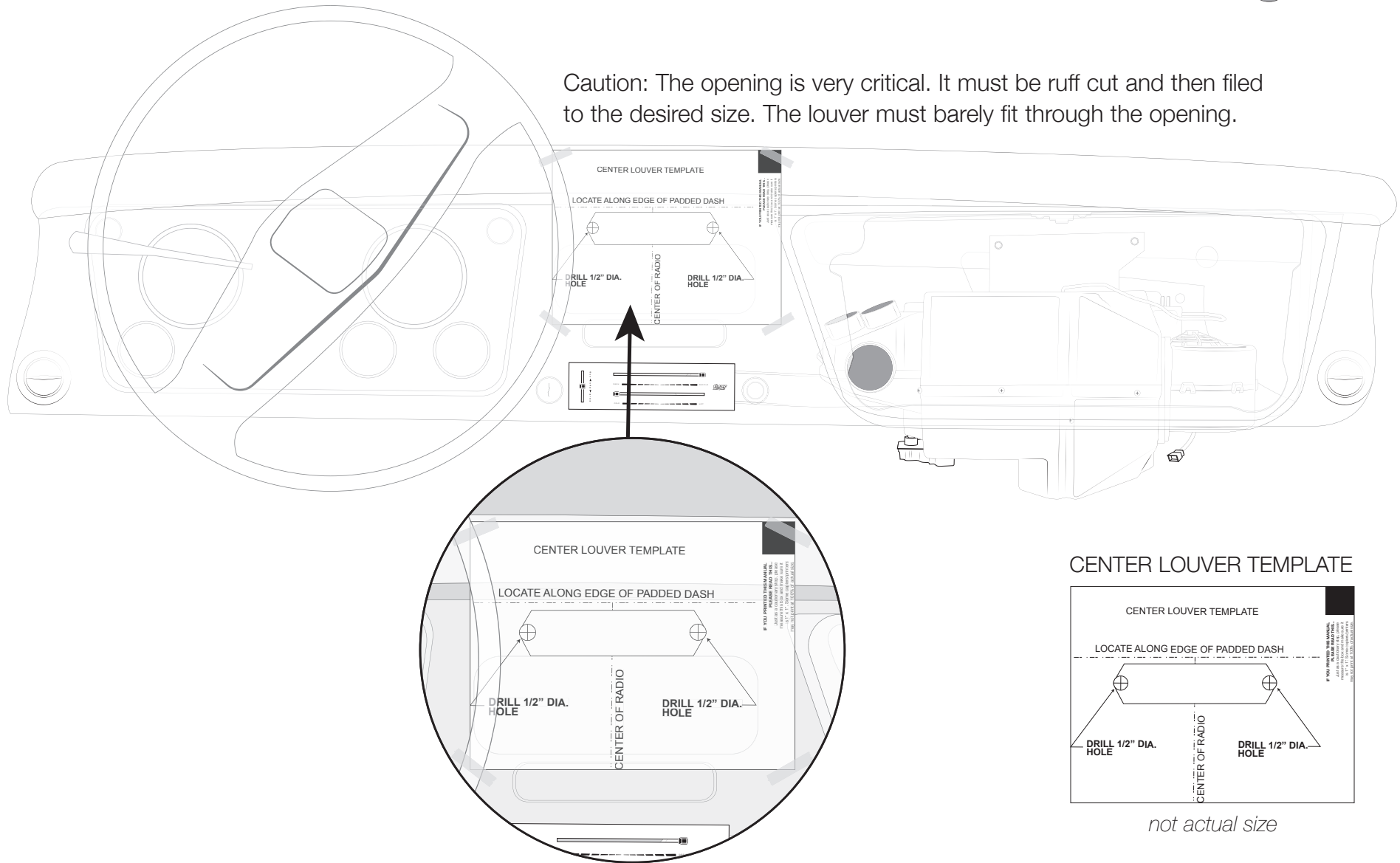

It is necessary to cut a hole in the instrument panel above the radio opening for the center louver. Locate in the instructions the center louver template. Use the template by taping template to the instrument panel. Carefully follow directions on template.

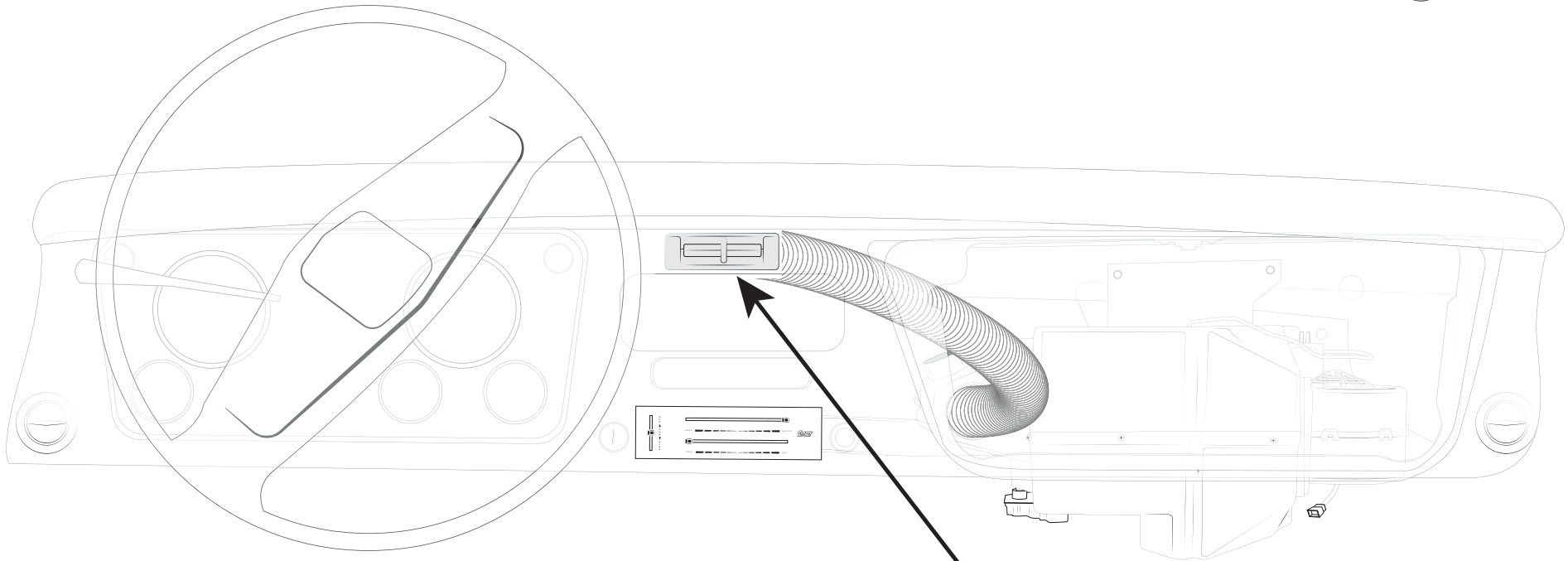

Install louver through the opening and attach using center louver hose adapter over the backside of louver. Locate in the kit (1) piece of 2 ½" diameter flex hose 2 ft long, cut to 18". Attach to the center louver adapter using (2) #8 x 3/8" pan head screws. Attach hose adapter to the center louver with two 1/4-20 phillips screws.

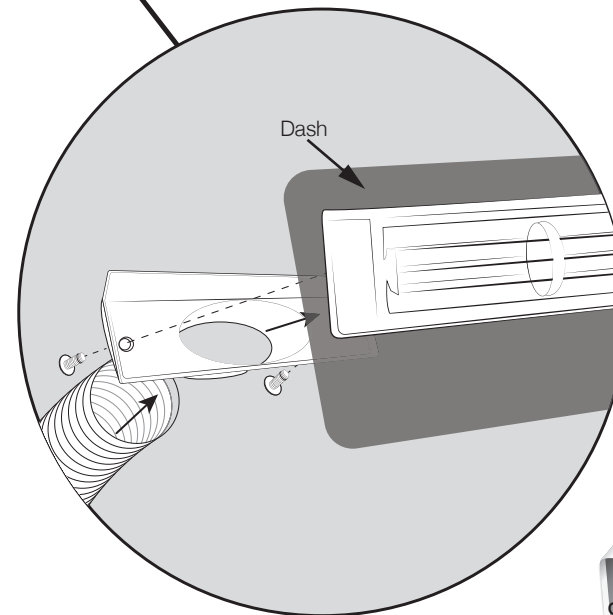

Check Duct Hose For Object Such As Wipers

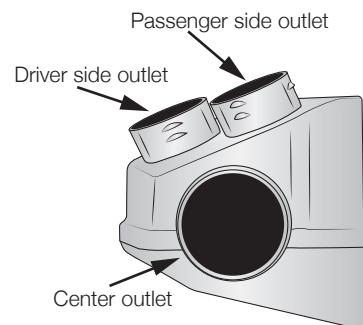

The smoother the route of the flex hoses the better the airflow.

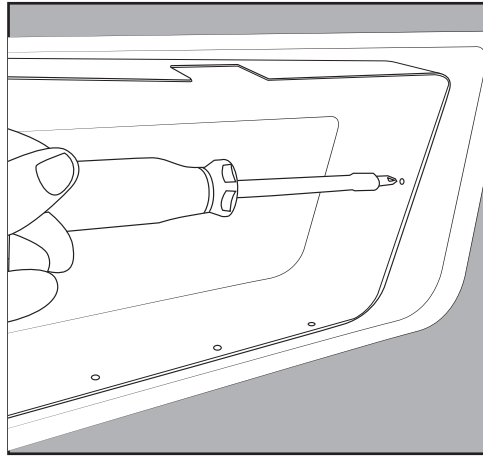

FIGURE 32

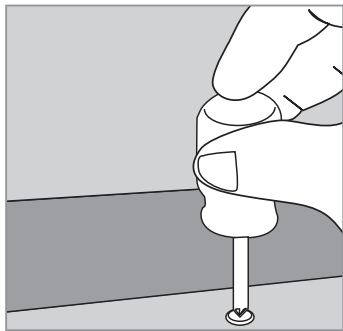
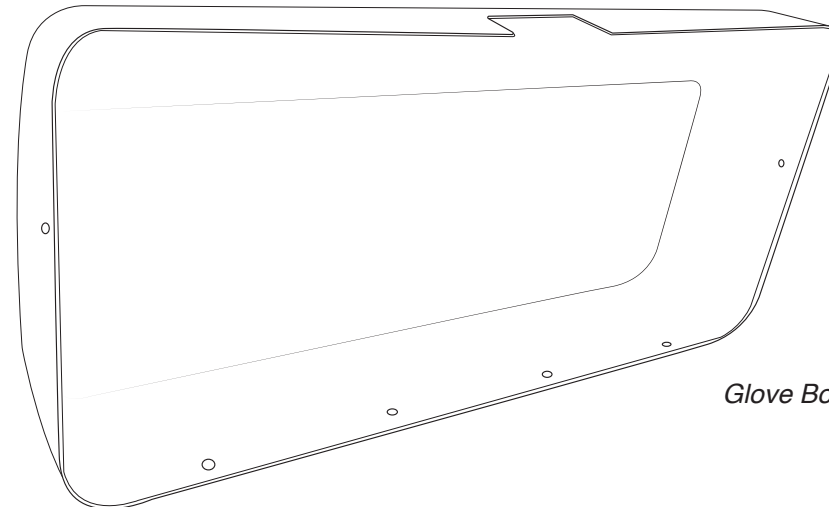

FIGURE 33

Locate the new glove box provided in kit. Install using original hardware (see figure 32-33).

Caution: Carefully check under the instrument panel for all cables, electrical harness, or flex hose that might interfere with the safe operation of the vehicle. Make sure that you cycle the windshield wipers to insure proper clearance of mechanism.



Glove Box Insert

We've included a replacement glovebox that you can install at this point. We've included screws, and you'll attach the new glovebox to the OEM glovebox door.

This completes the interior portion of the **PERFECT FIT-ELITE** installation process. This is a good time to make a final check that all the controls still move freely and that nothing is loose or hanging down.

The interior of your car should look pretty much the same as before you started (or better). Plus you probably got to know the underside of your dash a lot better and might even have repaired or upgraded components that needed attention.

THESE ARE THE PARTS YOU WILL NEED FOR THE ENGINE COMPARTMENT INSTALLATION

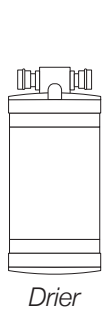

Drier

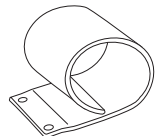

Drier Bracket

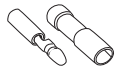

Splice and Bullet Connector



Ten #10 - 20 x 1/4" Screws

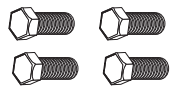

Four #1/4 x 5/8" Bolts

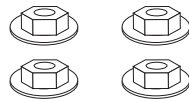

Four #1/4 Flange Nuts

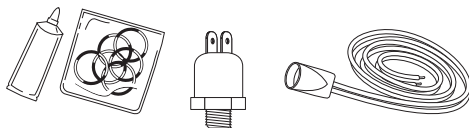

Pressure Switch and harness, Bag of O-rings and Mineral Oil Tube

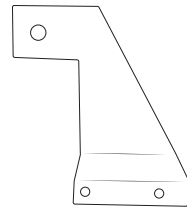

Condenser Bracket PN#0020-60

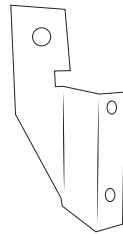

Condenser Bracket PN#0020-61

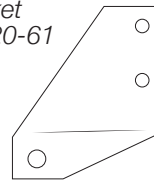

Condenser Bracket PN#0020-62

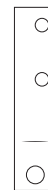

Condenser Bracket PN#0020-63



Two Washers PN# 0020-66

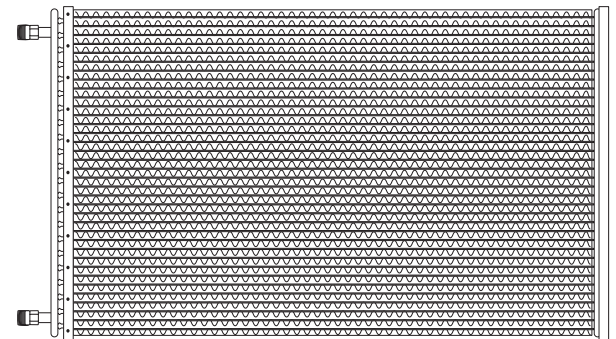

Condenser PN#11-1042

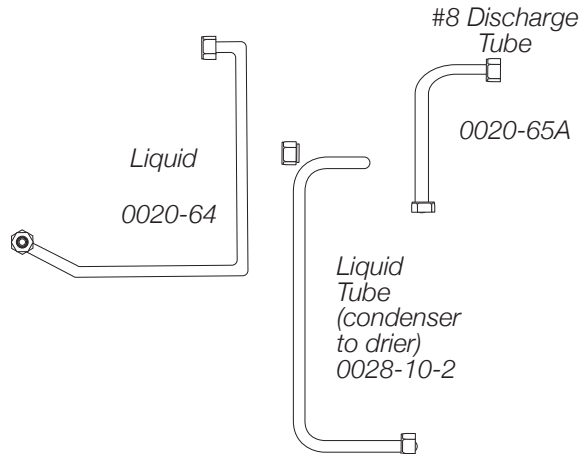

Liquid 0020-64

#8 Discharge Tube 0020-65A

Liquid Tube (condenser to drier) 0028-10-2

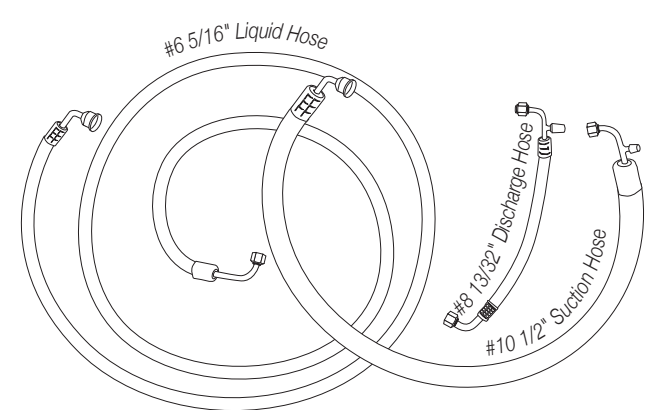

Three Refrigerant Hoses

At this time you will want to disconnect the battery and drain radiator. Remove the hood latch and retain the hardware for reinstallation.

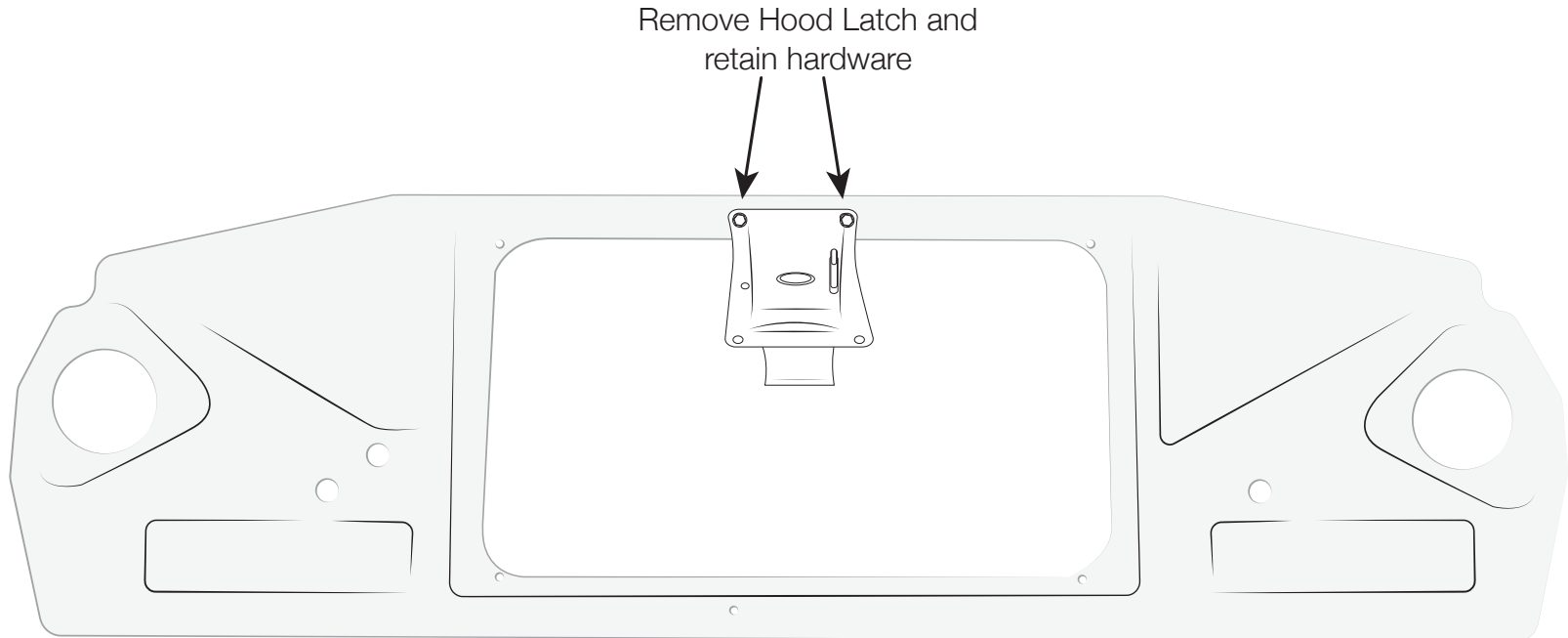

CONDENSER PREPARATION. You can perform most of the following steps on a clean flat surface like a workbench. Lay the condenser down so that both hose connections are on the **RIGHT SIDE** (the larger connection will be on top).

Locate condenser, Condenser Bracket PN#0020-62, Condenser Bracket PN#0020-63, and (4) #10 - 20 x 1/4" Screws. Attach brackets to the coil as shown.

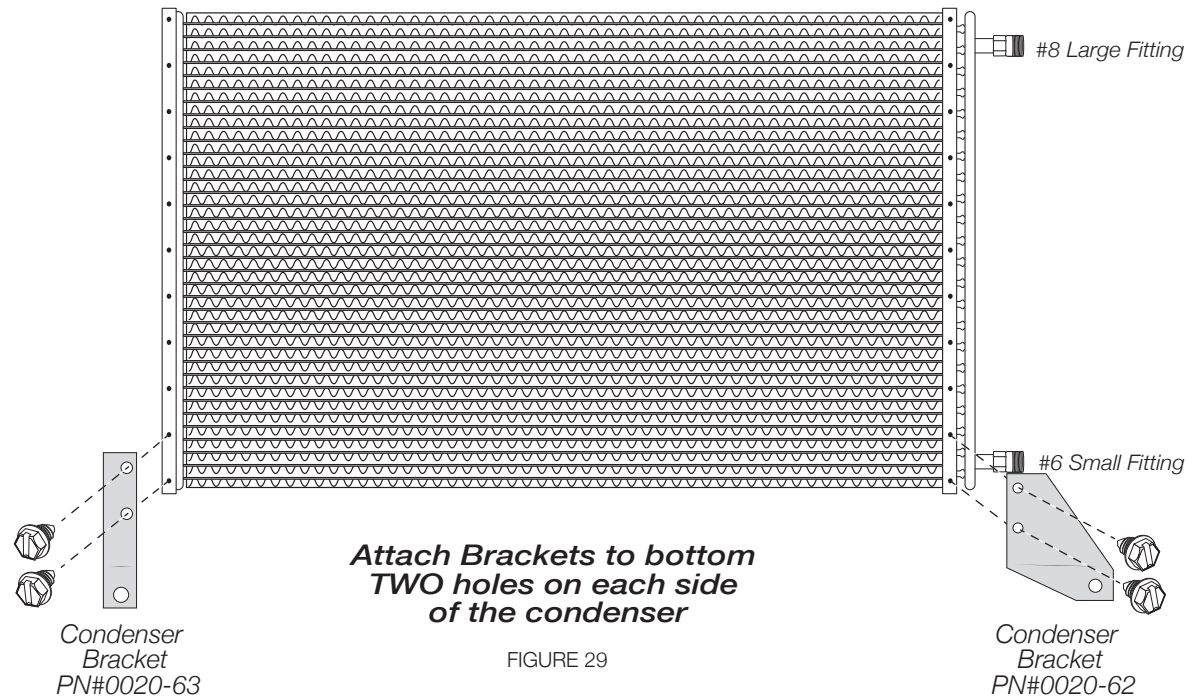
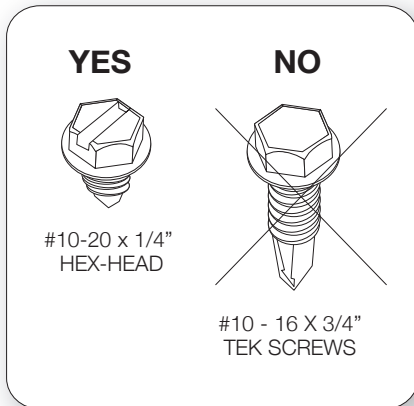

Install with bends toward you



CONDENSER PREPARATION. Lay the condenser down so that both hose connections are on the **LEFT SIDE** (the larger connection will be on top).

Locate condenser, Condenser Bracket PN#0020-60, Condenser Bracket PN#0020-61, and (4) #10 - 20 x 1/4" Screws. Attach brackets to the coil as shown.

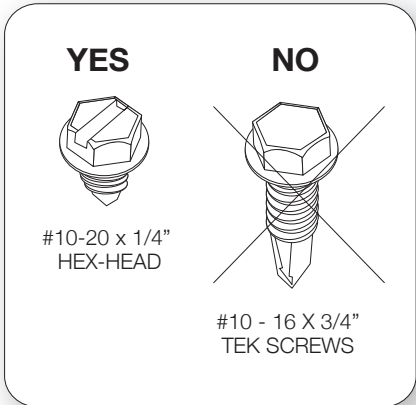
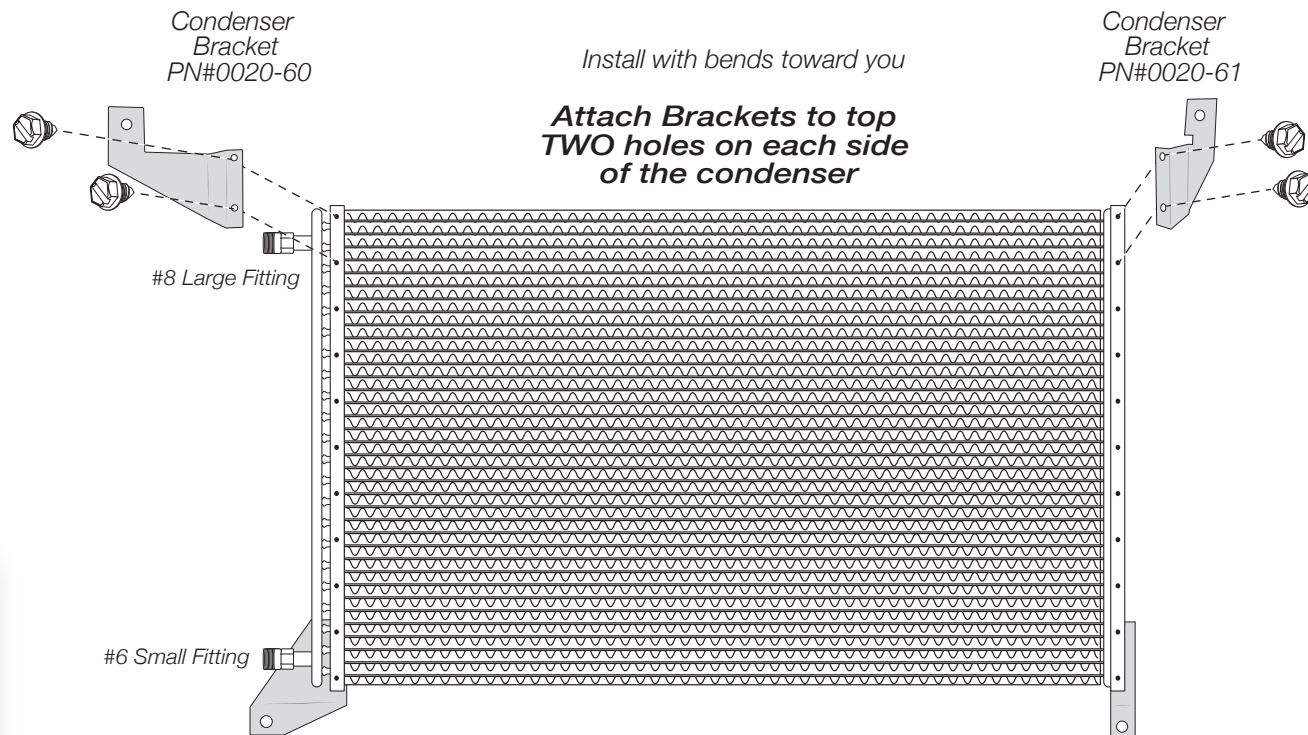

DRIER AND CONDENSER PREPARATION. Lay the condenser down so that both hose connections are on the **LEFT SIDE** (the larger connection will be on top). The drier is conveniently mounted on the left hand side of the condenser.

First insert the drier into the drier mounting bracket. Attach the drier liquid tube to the drier and also to the connection on the condenser (tighten connections at either end using supplied o-rings on both ends and a few drops of mineral oil to each o-ring). With these two combined it will easy to find the correct place to attach the drier bracket to the condenser with the included #10-20 x 1/4" screws (attach drier and bracket from the front of the condenser).



You can easily find the correct position for mounting the drier to the condenser by using the drier liquid tube as a gauge.

PRESSURE SWITCH: Screw the high-pressure switch into the port on the top of the drier. Go ahead and plug the pressure switch harness into the switch at this time (black electrical boot with two long white wires).

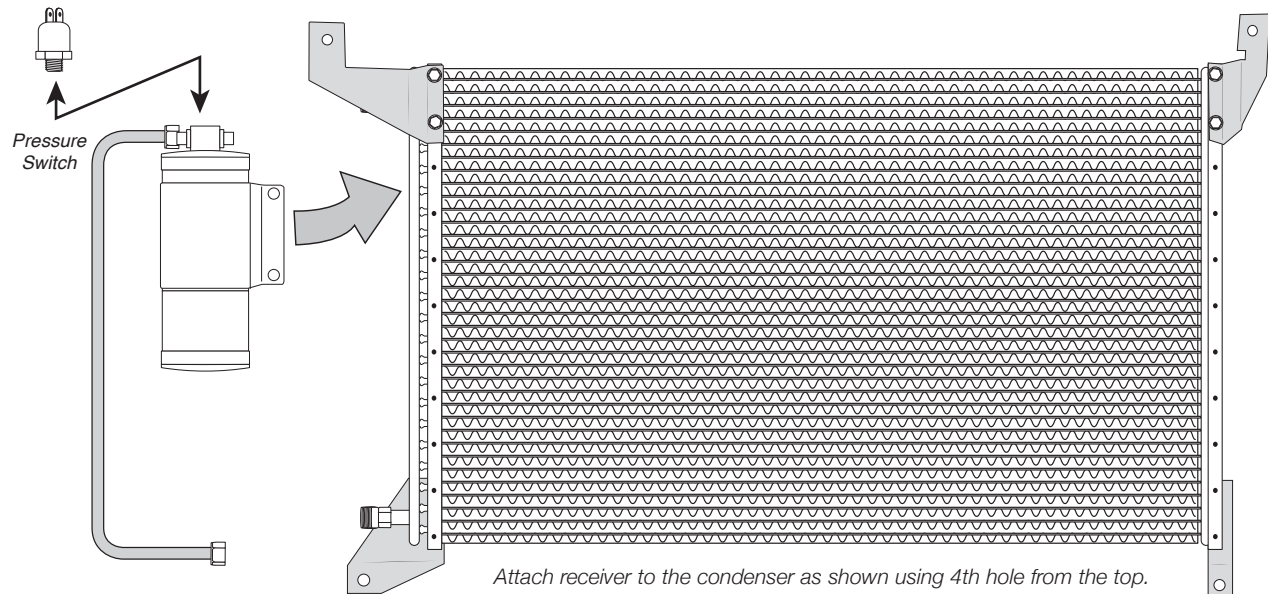

Attach receiver to the condenser as shown using 4th hole from the top. Use a few drops of mineral oil at the o-ring connections.

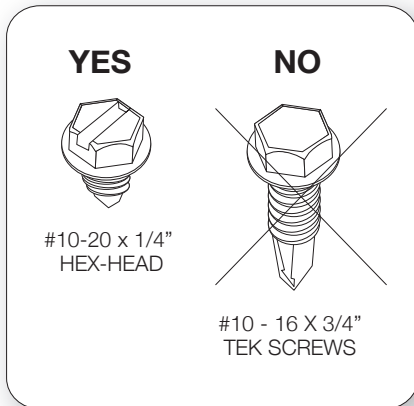

Reminder... Use two wrenches to tighten o-ring fittings

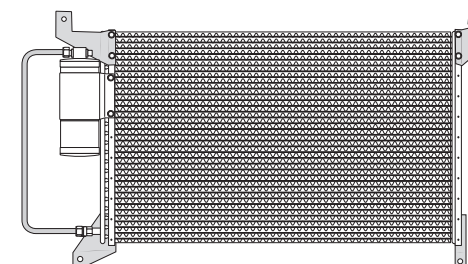
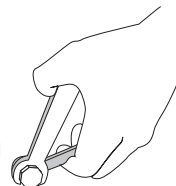

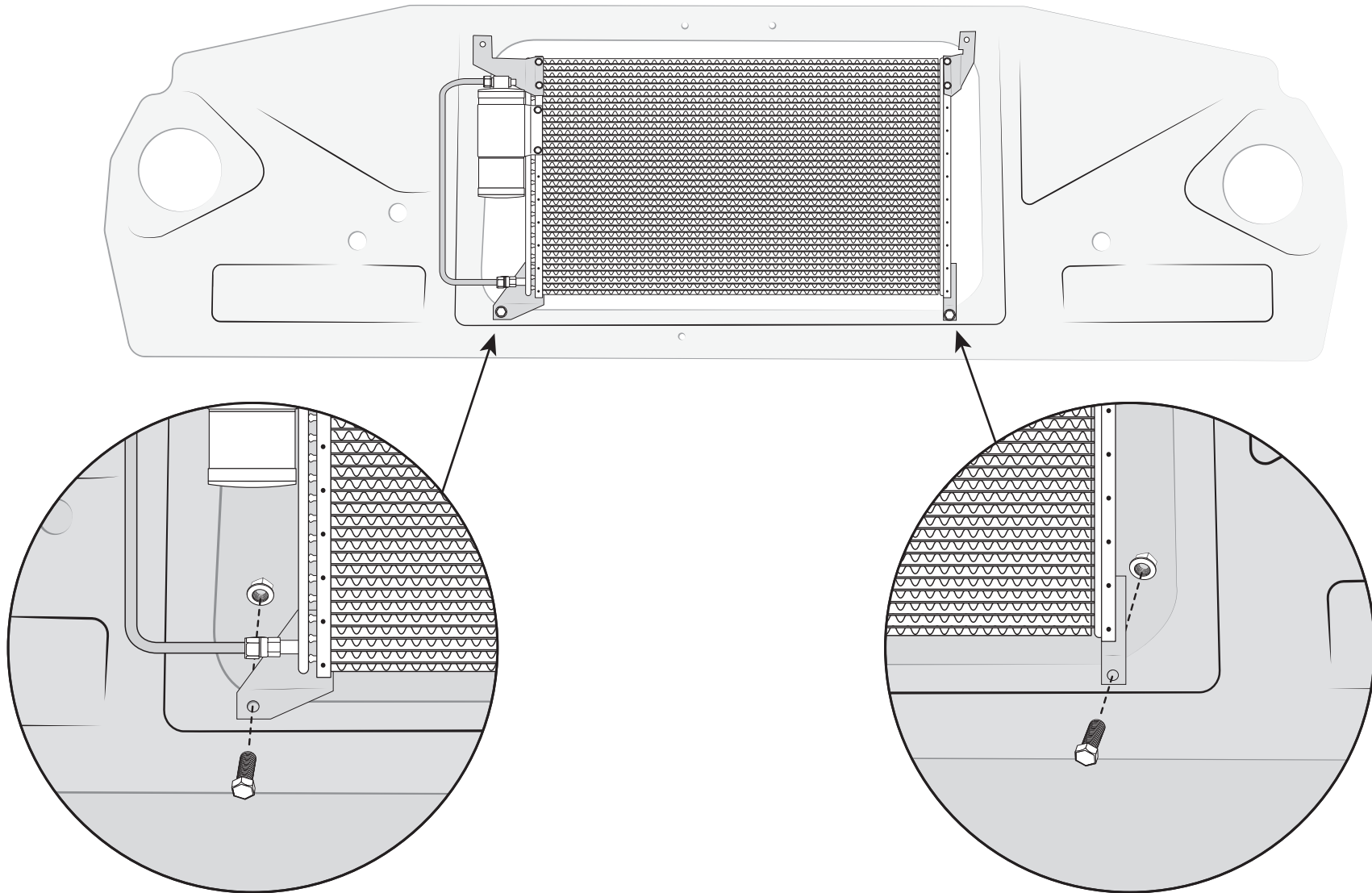

Locate the Passenger lower mounting bracket, (2) #10 x 1/2" hex head screw, (1) 1/4"-20 x 5/8" hex head screw, and (1) 1/4"-20 flange nut. Attach to the condenser and core support as shown. **Leave loose for mockup.**

Locate Drivers lower mounting bracket, (2) #10 x 1/2" hex head screws, (1) 1/4"-20 x 5/8" hex head screw, and (1) 1/4"-20 flange nut. Attach bracket to the condenser and core support as shown. **Leave loose for mockup.**

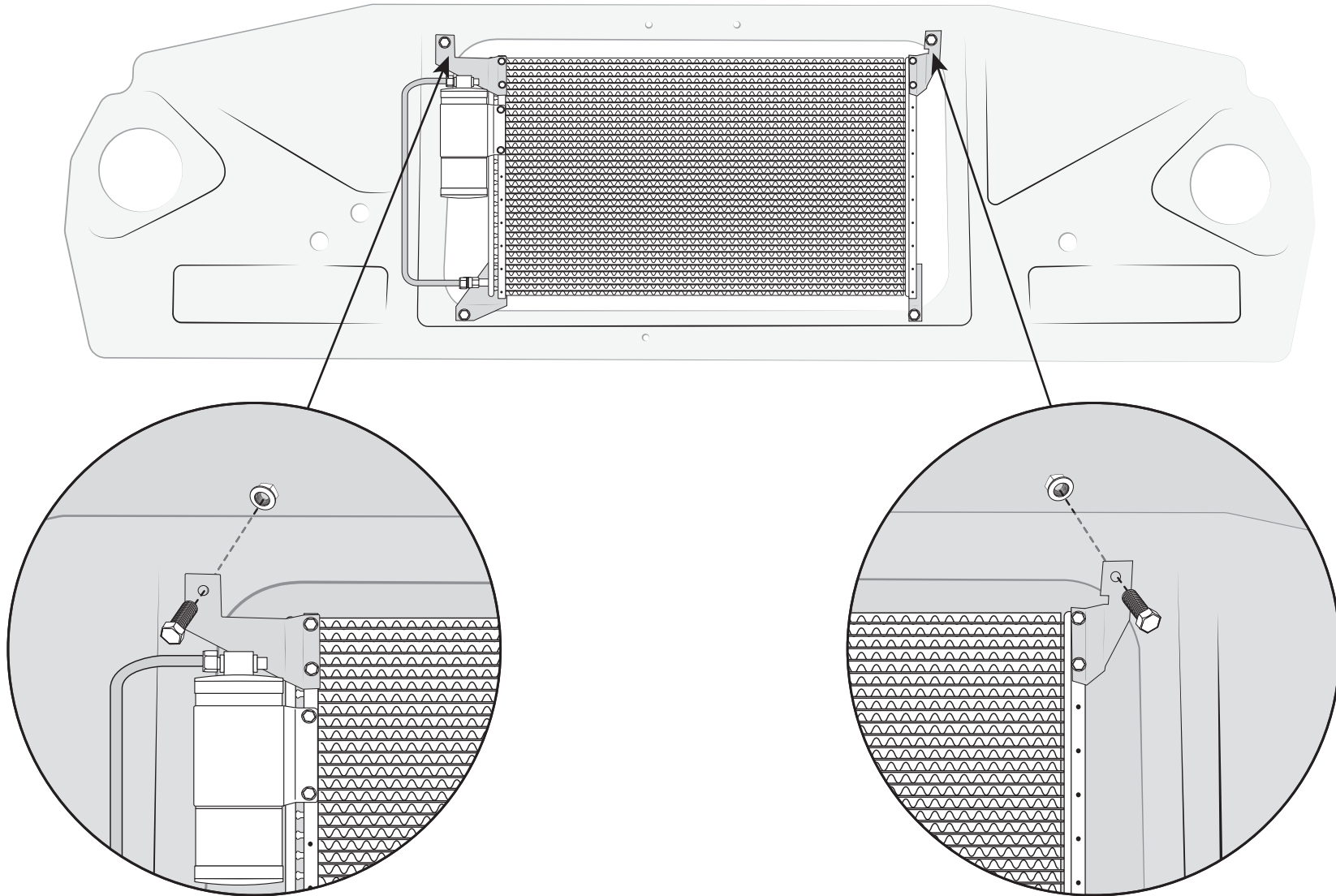

Locate the passenger upper mounting bracket, (2) #10 x 1/2" hex head screw, (1) 1/4"-20 x 5/8" hex head screw, and (1) 1/4"-20 flange nut. Attach to the condenser and core support as shown. **Leave loose for mockup.**

Locate upper drivers mounting bracket, (2) #10 x 1/2" hex head screws, (1) 1/4"-20 x 5/8" hex head screw, and (1) 1/4"-20 flange nut. Attach bracket to the condenser and core support as shown. **Leave loose for mockup.**

It is necessary to drill a 1 3/8" (*one and three eights*) hole directly in line with the upper #8 large tube connection.

Place condenser in place and locate the hole. Remove condenser assembly and drill hole.

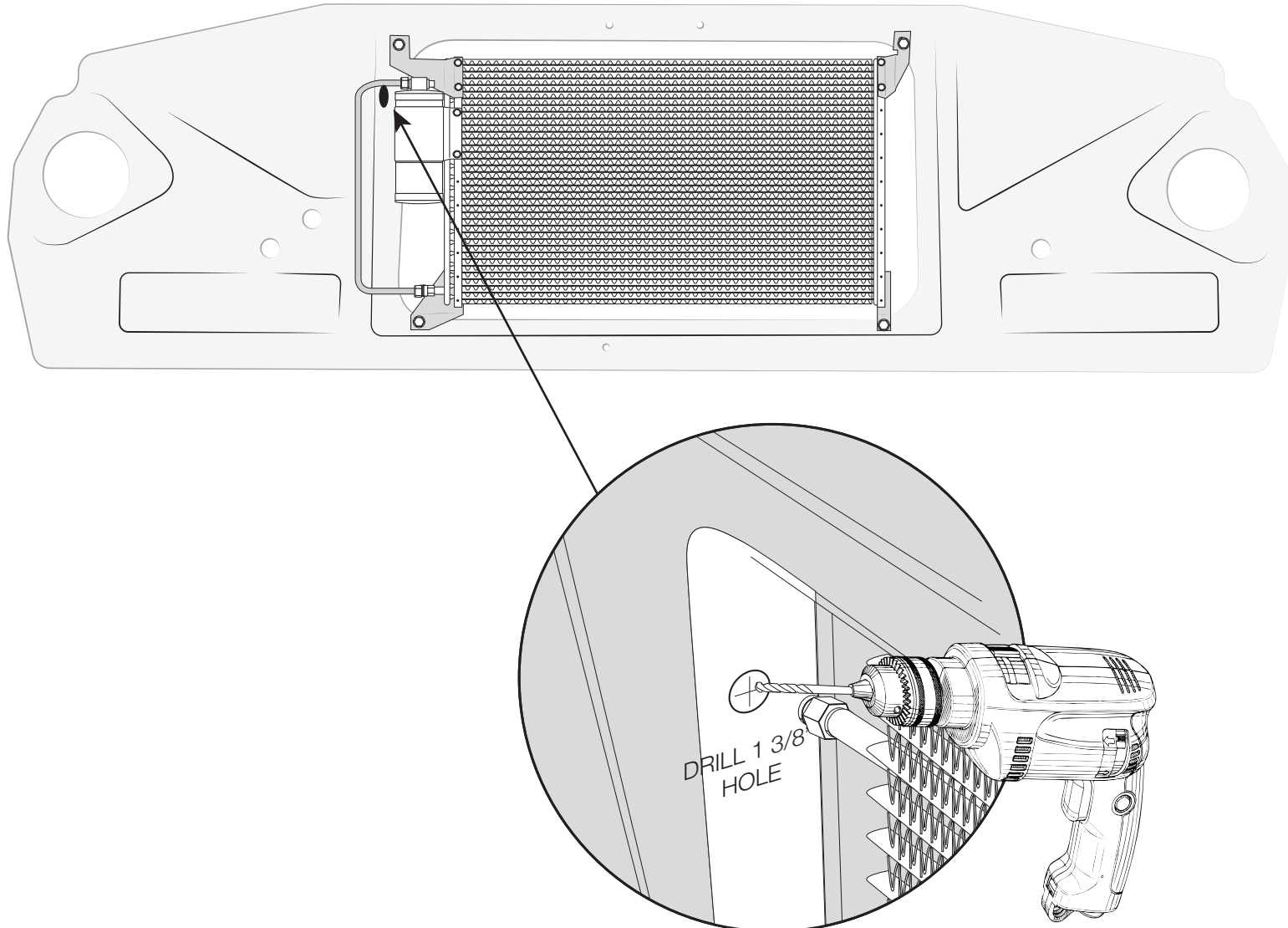

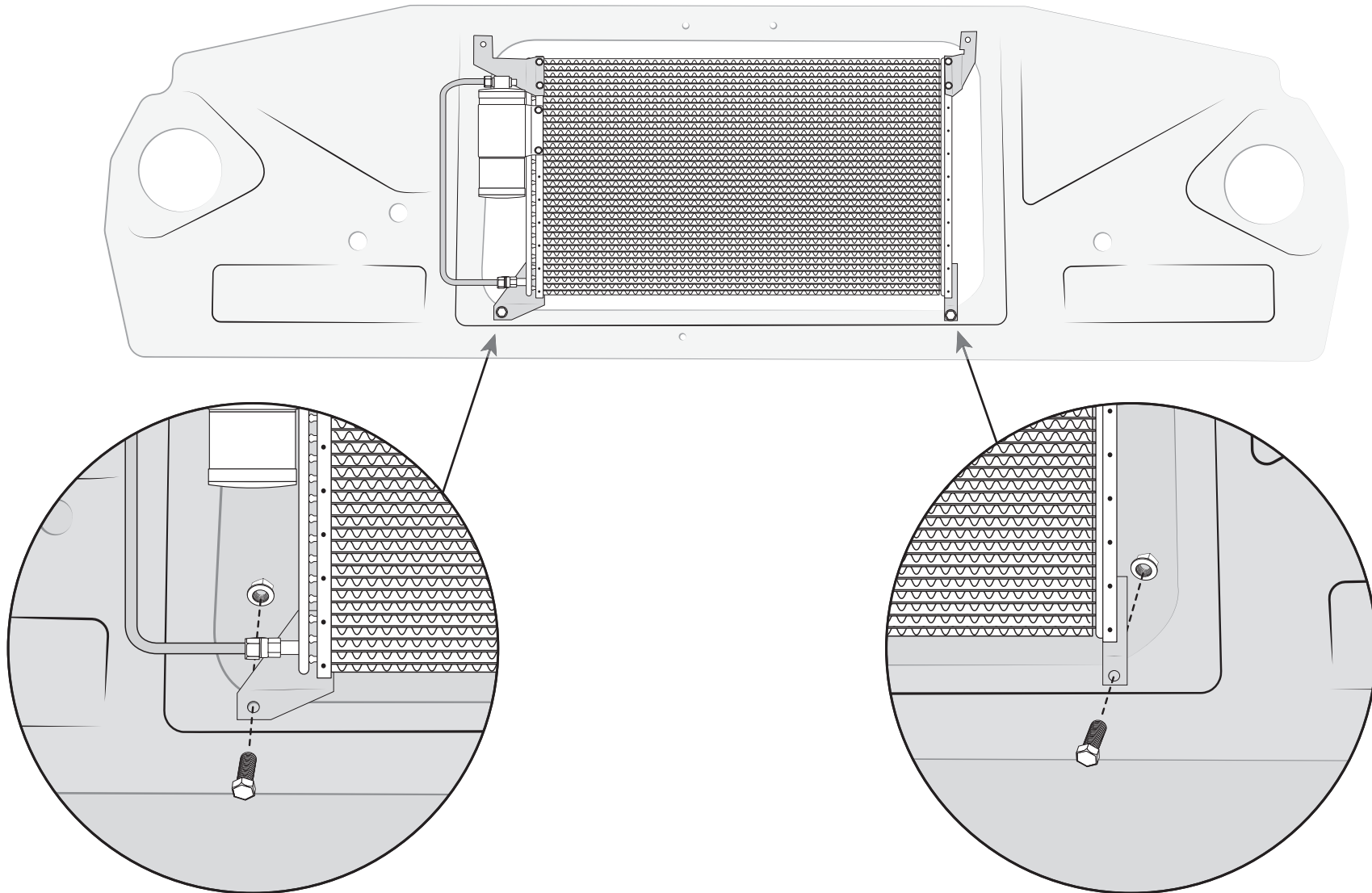

Locate the Passenger lower mounting bracket, (2) #10 x 1/2" hex head screw, (1) 1/4"-20 x 5/8" hex head screw, and (1) 1/4"-20 flange nut. Attach to the condenser and core support as shown. Tighten securely.

Locate Drivers lower mounting bracket, (2) #10 x 1/2" hex head screws, (1) 1/4"-20 x 5/8" hex head screw, and (1) 1/4"-20 flange nut. Attach bracket to the condenser and core support as shown. Tighten securely.

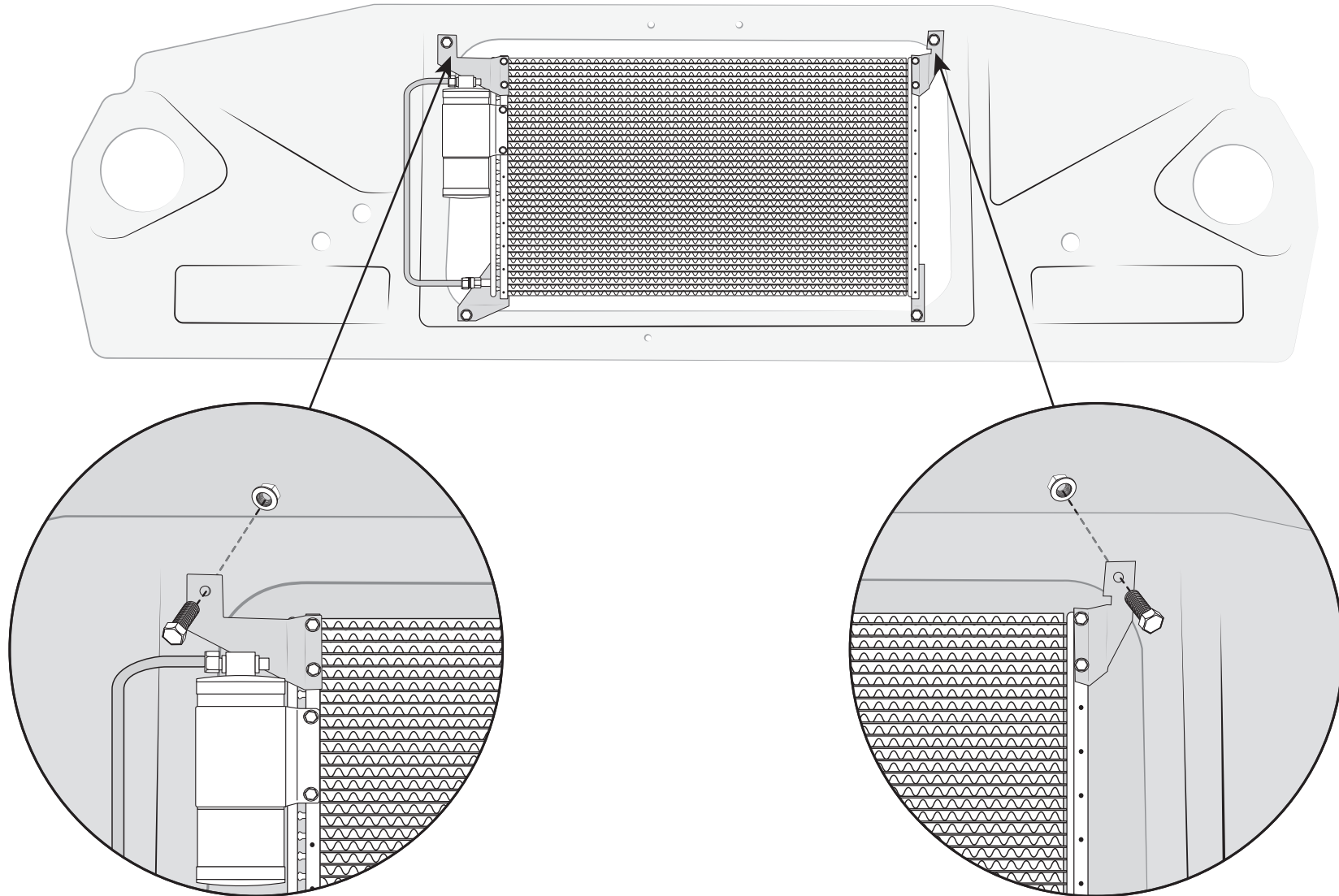

Locate the passenger upper mounting bracket, (2) #10 x 1/2" hex head screw, (1) 1/4"-20 x 5/8" hex head screw, and (1) 1/4"-20 flange nut. Attach to the condenser and core support as shown. Tighten securely.

Locate upper drivers mounting bracket, (2) #10 x 1/2" hex head screws, (1) 1/4"-20 x 5/8" hex head screw, and (1) 1/4"-20 flange nut. Attach bracket to the condenser and core support as shown. Tighten securely.

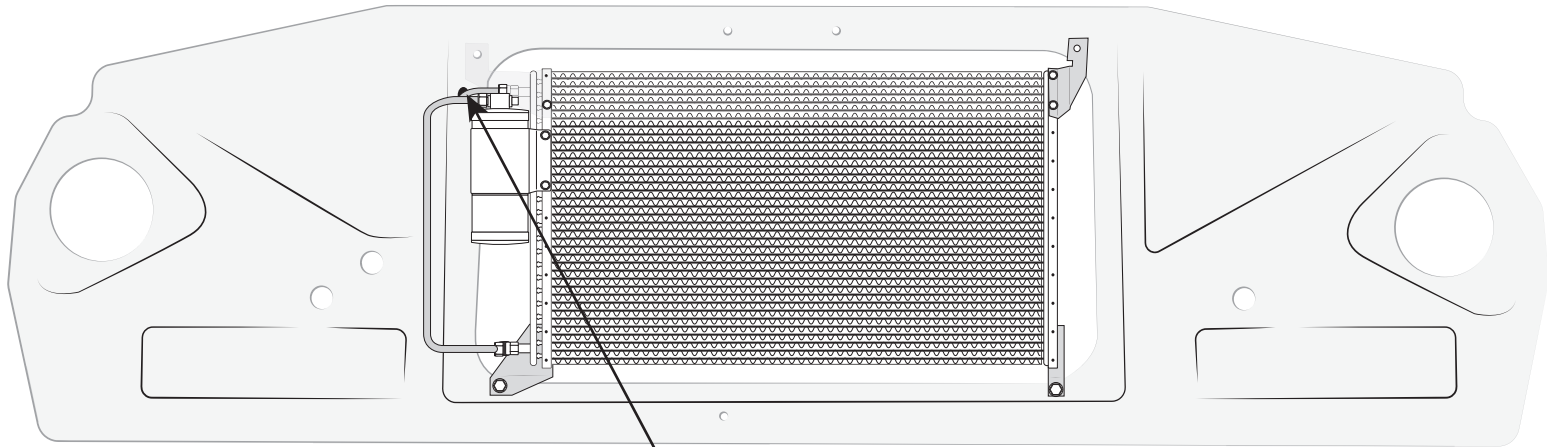

Locate #8 discharge tube pn# 0020-65A and (1) #8 oring.

Insert tube between battery radiator, Then through the 1 3/8" hole you drilled and attach to the (1) #8 o-ring and a few drops of mineral oil.

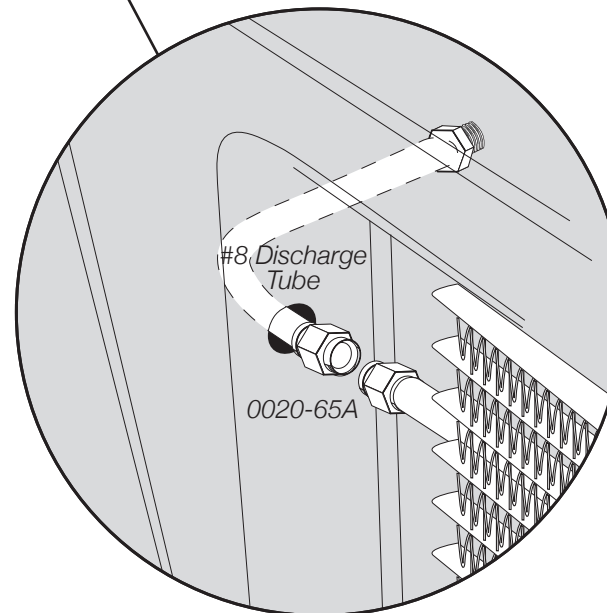

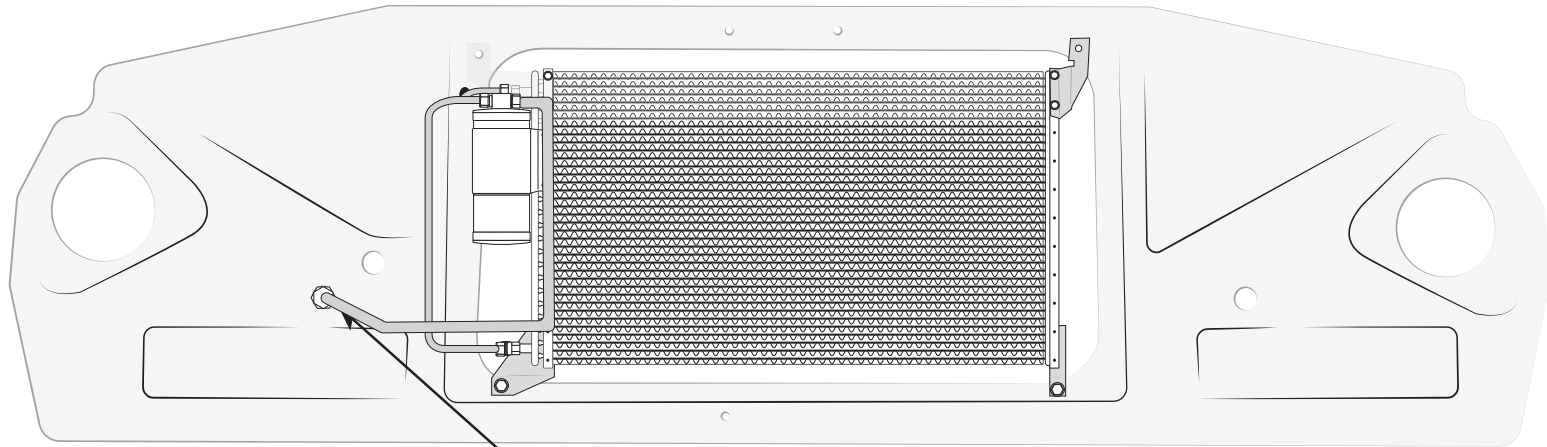

Locate #6 liquid tube pn# 0020-64 and (1) #6 oring.

Insert tube behind and under battery box attach to the (1) #6 o-ring and a few drops of mineral oil.

Washers will hold #6 liquid tube pn# 0020-64 in place by tightening nuts against core support.

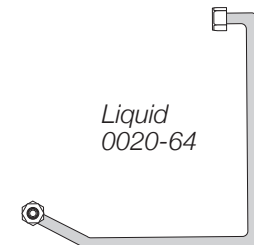
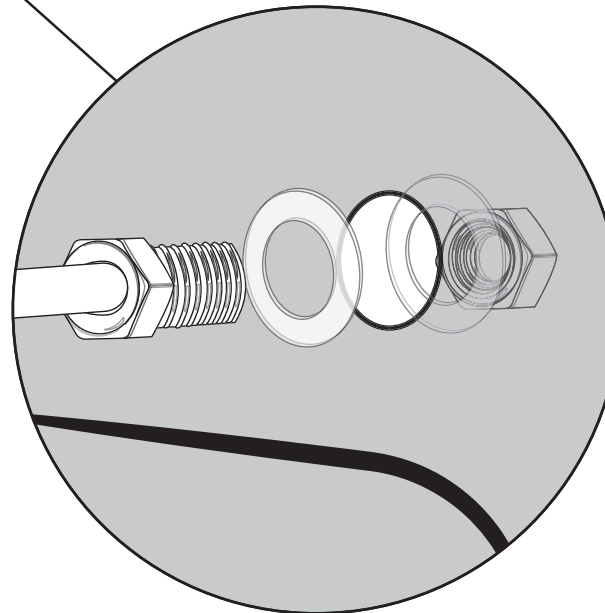

Connecting the Hoses

Install the compressor kit. Included was a premium compressor kit with all the parts you'll need to install the compressor. This kit includes instructions specifically written for your engine. Once you've installed the complete compressor kit, continue on to connecting the hoses.

CONNECTING THE HOSES:

Based on PASSENGER or DRIVERS SIDE compressor mounting see illustrations for routing.

The #10 (**LARGEST**) refrigerant hose. Attach end with service fitting to the compressor using (1) #10 o-ring and a few drops of mineral oil. Attach other end to #10 fitting at the firewall. Attach using one #10 o-ring and a few drops of mineral oil. Tighten securely.

The #6 (**SMALLEST**) refrigerant hose. Route behind fender and to the connection on firewall. Attach using two #6 o-ring and a few drops of mineral oil.

The #8 (**MEDIUM**) refrigerant Hose. Route across engine and to the connection on compressor. Attach using two #8 o-ring and a few drops of mineral oil.

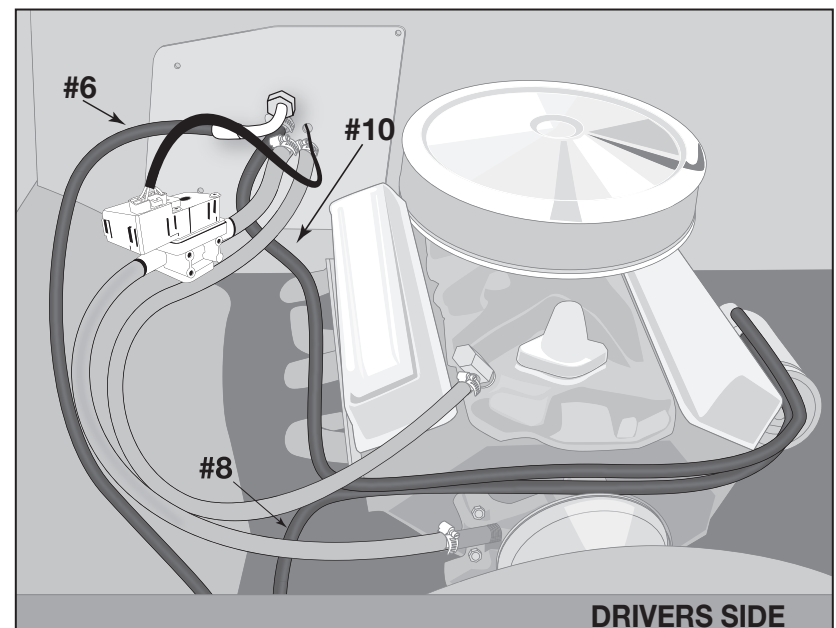
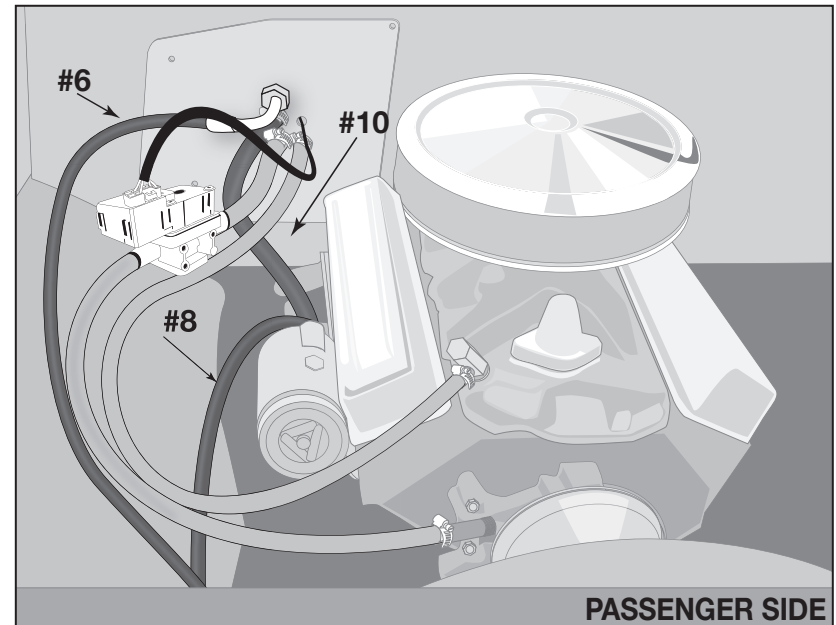

TWO WRENCH METHOD



Reminder...
Use two
wrenches to
tighten o-ring
fittings

New A/C System Preparation... A MUST READ!

Please read through these procedures before completing this new A/C system charging operation.

A licensed A/C technician should be utilized for these procedures to ensure that your new system will perform at it's peak, and that your compressor will not be damaged.

1. Your radiator/cooling system is an integral part of your new system. Please insure that you have a 50/50 mix of distilled water and antifreeze. The heater coil **MUST** be purged (cycle heater control valve) to make sure no water, without antifreeze, is in the heater coil before you charge the A/C system.
2. Evacuate the system for a minimum of 45 minutes.
3. Your new compressor **MUST** be hand turned 15-20 revolutions before and after charging with liquid. Failure to do this may cause the reed valves to become damaged. This damage is **NOT** covered by your warranty.
4. Your new system requires 1.5lbs (24oz) of R134a refrigerant.
5. Your new compressor comes charged with oil - **NO** additional oil is necessary.
6. Ensure that the new belt is tight.
7. **DO NOT** charge system with liquid refrigerant!



Recommended Test Conditions:

(After system has been fully charged and tested for basic operation)

- Determine the temperature outside of the car
- Connect gauges or service equipment to high/low charging ports
- Place blower fan switch on medium
- Close all doors and windows on vehicle
- Place shop fan directly in front of condenser
- Run engine idle up to approximately 1500 rpm

ACCEPTABLE OPERATING PRESSURE RANGES:

1. High-side pressures: 150-275 PSI
2. Low-side pressures: 10-25 PSI(in a steady state)

Readings above are based on an ambient temperature of 90° with an adequate airflow on condenser.

CAUTION! When mounting your compressor and/or adjusting the belt use caution. Mount by using the centerline of the oil fill plug as your guide. The compressor can **ONLY** be mounted inbetween the 9 to 3 positions. **DO NOT** mount inbetween the 4 to 8 positions.

This can cause compressor failure.

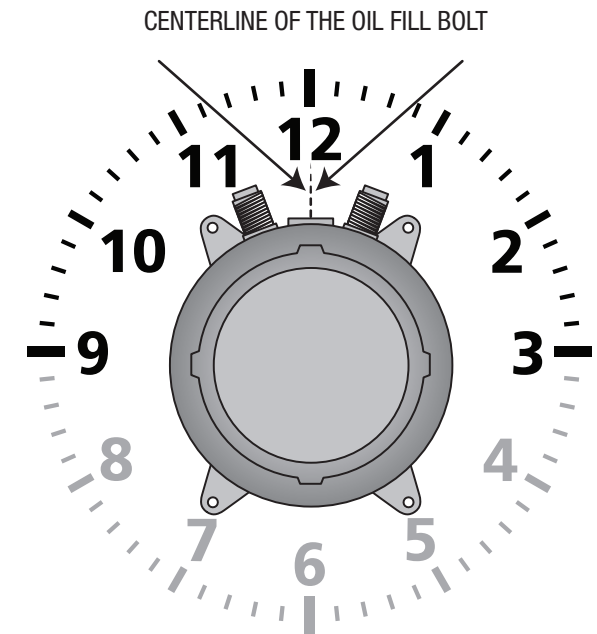

Do NOT tilt, shake or turn refrigerant can upside-down OR use a charging station to install refrigerant while the engine is running. Doing so will direct liquid refrigerant into the compressor piston chamber, causing damage to reed valves and/or pistons and/or other components, as well as potentially seizing the compressor. Allow a minimum of 30 minutes for liquid to "boil off." You must hand turn the compressor hub (not the pulley) a minimum of 15 complete revolutions prior to starting the engine with the clutch engaged.



Troubleshooting Guide

Test conditions used to determine system operation:

These test conditions will simulate the effect of driving the vehicle and give the technician the three critical readings that they will need to diagnose any potential problems.

- A. Connect gauges or service equipment to high/low charging ports
- B. Place blower fan switch on medium
- C. Close all doors and windows on vehicle
- D. Place shop fan in front of condenser
- E. Run engine idle up to 1500 RPM

Acceptable operating pressure ranges (R134A type):

1. High-side pressures: 150-275 PSI
- *note: general rule is two times the ambient/daytime temperature plus 15-20%
2. Low-side pressures: 10-25 PSI in steady state

Charge as follows: R134a = 1.5lbs (24oz)

No additional oil is necessary in our new compressors.

Typical problems encountered in charging systems - noisy compressor:

A noisy compressor is generally caused by charging a compressor with liquid or overcharging.

- A. If the system is overcharged both gauges will read abnormally high readings. This is causing a feedback pressure on the compressor causing it to rattle or shake from the increased cylinder head pressures. System must be evacuated and re-charged to exact weight specifications.
- B. Installing the heater control valve in the incorrect hose will cause the system to cool at idle and gradually warm up when the RPM's of the engine rise. The heater control is a directional valve; make sure the water flow is with the direction of the arrow. As the engine heats up, the water transfers the heat to the coil thus overpowering the a/c coil. A leaking or faulty valve will have a more pronounced affect on the unit's cooling ability. Installing the valve improperly - such as having the flow reversed - will also allow water to flow through which inhibits the cooling. Check for heat transfer by disconnecting hoses from the system completely. By running down the road with the hoses looped backed through the motor you eliminate the possibility of heat transfer to the unit.
- C. Evaporator freezing can occur both externally and internally on an evaporator core. External freeze up occurs when the coil can't effectively displace the condensation on the outside fins so the water forms ice. The evaporator core resembles a block of solid ice, it restricts the flow of air that can pass through it, which gives the illusion of the air not functioning. The most common cause of external freezing is the thermostat setting and humidity in the passenger compartment. All door and window seals should be checked in the event of constant freeze-up. A thermostat is provided with all units to control the cycling of the compressor.

D. Internal freeze-up occurs when the system has too much moisture inside. The symptoms of internal freeze-up often surface after extended highway driving. The volume of air stays constant but the temperature of the air gradually rises. When this freezing occurs the low-side pressure will drop and eventually go into a vacuum. At this point, the system should be checked by a professional who will evacuate the system and change the drier.

E. The condenser works best in front of the radiator with a large supply of fresh air. Abnormally high pressures will result from improper airflow. Check the airflow requirements by placing a large capacity fan in front of the condenser and running cool water over the surface. Pressures dropping significantly will indicate the need for better airflow.

F. Incorrect condenser capacity will cause abnormally high head pressures. A quick test that can be performed is to run cool water over the condenser while the system is operating, if the pressures decrease significantly, it is likely a airflow or capacity problem.

G. An expansion valve failure is generally caused by dirt or debris entering the system during assembly. If an expansion valve fails it will be indicated by abnormal gauge readings. A valve that is blocked will be indicated by high-side that is unusually high and the low-side unusually low (may even go into a vacuum.) A valve that is stuck open will be indicated by both the pressures rising to unusually high readings and tend to move toward equal readings on the gauges.

H. A restriction in the cooling system will cause abnormal readings on the gauges. A high-side restriction, between the compressor and the drier inlet, will be indicated by the excessively high discharge reading. These simple tests can be performed by a local shop and can help determine the extent of the system's problem.



Troubleshooting Your Classic Auto Air A/C System

Problem: system is not cooling properly

Issue: cold at idle. warmer when raising engine RPMs

Make sure the water valve is positioned correctly.

The water valve is a directional valve and should be installed with the arrow pointing towards the water pump. It should be connected to the heater hose that runs from the heater core to the water pump. If the water valve is incorrectly connected to the hose it allows water to circulate through the system via the heater core over-powering the cooling effect of the a/c coil.

Step 1: Check placement of the water valve and correct if needed.

Step 2: If changing the location of the water valve does not rectify the issue, the water valve may be permanently damaged and may need to be replaced. To check the integrity of the water valve you will need to completely remove the heater core's water hoses and "loop" together. By doing so, the heater system will be completely removed from the possibilities. If the system now cools then the water valve will need to be replaced.

Verify adequate air flow to the condenser.

The condenser's function is to dissipate heat. Your air conditioning system will not cool your vehicle's cabin properly if you do not have an adequate airflow across the condenser.

Step 1: Connect gauges to a/c hoses. When ambient temp is 90°, pressures should be:

Low-side pressures: 10-25 PSI

High-side pressures: 150-275 PSI

If the low-side pressures are normal but the high-side pressures are high then there might be an airflow issue and you will need to test the airflow to the condenser.

Test airflow to the condenser.

Step 1: Place a piece of paper on the condenser with the car idling to see if the paper is held in place.

Step 2: With the car still idling, attach gauges and place a large capacity fan in front of the condenser. Check the pressures to see what happens.

Step 3: With the car still idling and the gauges still attached, pour water down the front of the condenser. Check the pressures again to see what happens.

If the paper was held in place then you are getting some air flow. If the high-side decreases during step 2 and step 3 then your condenser is not getting enough air which is stopping your system from cooling properly. To correct this issue, you will need a more powerful mechanical fan.

Confirm the correct refrigerant charge is in the system.

All of our systems should be charged with 1.5lbs (24oz) of R134a refrigerant only. If overcharged, you will need to evacuate the system and recharge with the correct amount.*

Measurement meanings:

1. Low temp and high pressure seems to be equal = malfunctioning expansion valve that is stuck open.
2. High side is extremely high and low side is extremely low (possibly into vacuum) = blockage in the system. Remove hoses and blow cold compressed air through it in both directions. Re-check your pressures. If pressures do not change then it is possible that your expansion valve is stuck closed and would have to be replaced.

***Compressor Concerns:**

If you have a noisy compressor, it is due to the improper charging with liquid or overcharging. An overcharged compressor will cause rattling. A compressor charged with pure liquid produces a high probability of bent reed valves. When the reed valves get bent they will create a tapping sound. Ensure your system is charged with 1.5lbs (24oz) of R134a refrigerant to avoid compressor related cooling issues.

CENTER LOUVER TEMPLATE

LOCATE ALONG EDGE OF PADDED DASH

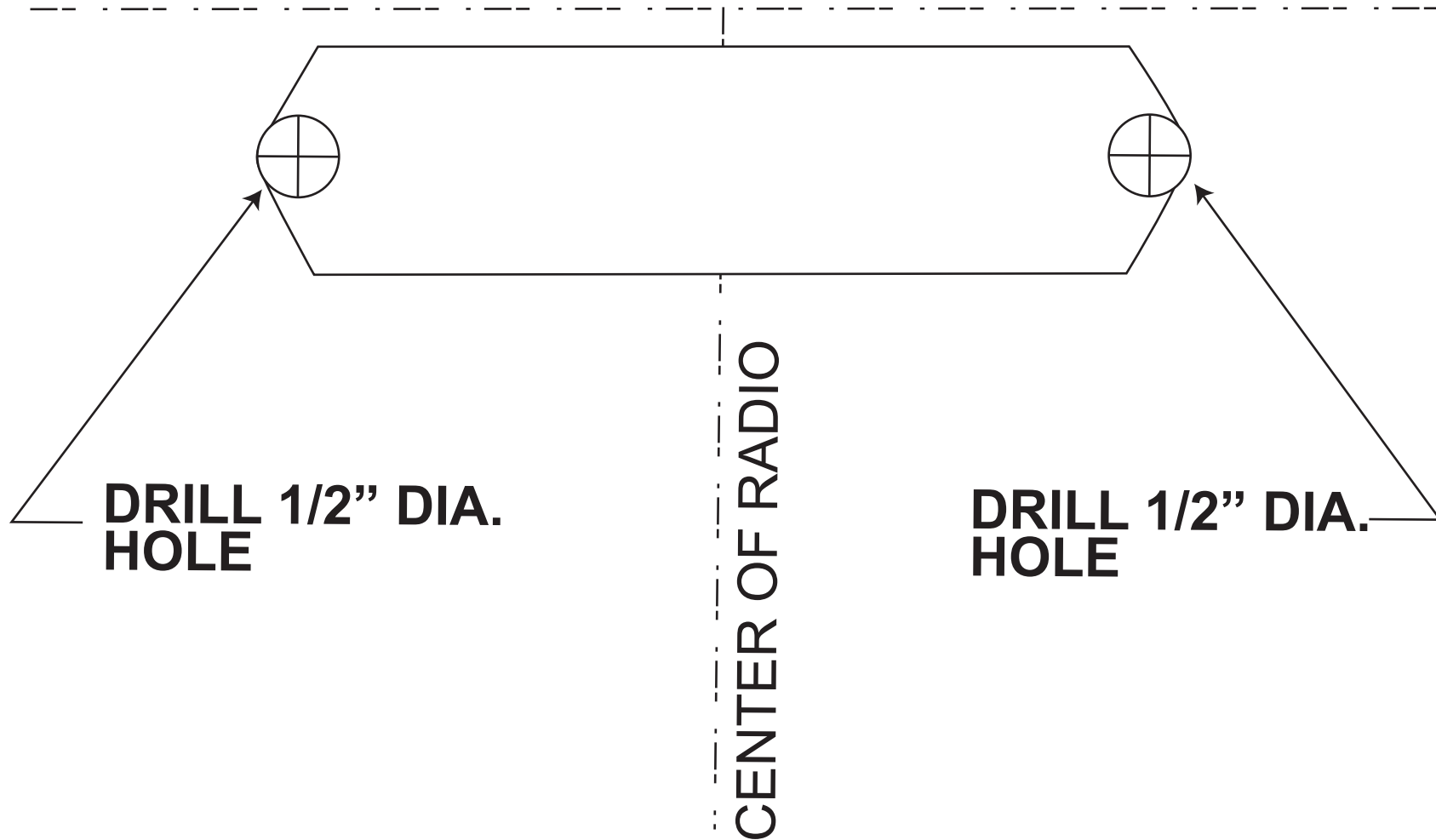

**IF YOU PRINTED THIS MANUAL
PLEASE READ THIS...**
Just as a cautionary step, please
measure this box and make sure it
is 1" x 1". Some copiers/printers
may not print at 100% of actual size.

