

MORRISON



Chassis & Suspension Components

2015 Catalog

Straight Talk From Art...

With over three years of engineering and testing on our new Multilink IRS, we were proud to release it to the public in February of 2014. As soon as it was available, it turned out to be a phenomenal success. Focusing on our motto of "Technology in Motion", and delivering the most state-of-the-art rear suspension that the aftermarket has to offer, we have been



Art (l) and Craig Morrison (r) have long demonstrated the ability to provide customers with products they desire.

able to provide a level of technology and performance that previously was only obtainable with the a purchase of a new vehicle. Integrating this fantastic new rear suspension into existing as well as new chassis designs, we are continuing to push the performance envelope further than we ever have before.

Our Multilink IRS hit the ground running in 2014 thanks to a few well known members of the Pro-Touring world. While we have had extensive R&D testing on our own test car, we partnered up with Mary Pozzi to give us some valuable on-track feedback. Participating at numerous track day, Goodguy and SCCA autocross events, Mary has tested the Multilink harder than

anything we could do internally. It was great to see that after the many years of engineering, research and design, there were no changes that came about as a result of this brutal on-track torture. Testing at this year's Super Chevy Suspension Challenge provided equally impressive numbers: 1.02g on the skidpad, 48.9 mph on a 60' spacing slalom and 5 seconds faster around The Streets of Willow Springs than a C5 Corvette. For more information about this test and road review please see the January '15 issue of Super Chevy Magazine. At the Goodguys Southwest Nationals in Scottsdale, Arizona, Mary was the number one qualifier at the "Dual in the Desert" autocross finals, finishing a very respectable 4th overall. The jump in performance from the previous year definitely drew the attention of her fellow competitors. Her husband and equally accomplished road racer, David Pozzi, is also installing one of our IRS subframes into his '68 Camaro. We look forward to seeing this track day monster hit the road course.

Over the course of this past year we traveled to various Goodguys and NSRA shows and the Multilink IRS sparked many people's curiosity. Being something completely new to the aftermarket we also caught the attention of the National Street Rod Association where we were awarded with the "New Product of the Year" award. There are going to be many installation stories coming out soon, so stay tuned! We have a first and second gen Camaro install story as well as a Tri5 IRS chassis build coming up. We will keep you posted on

when these stories go to print. In addition to Mary's 2nd Gen Camaro hitting the track, we have had numerous customer projects started this year featuring the Multilink IRS. Some of these include a '64 Mustang, '65 Impala, numerous 1st and 2nd gen Camaros, '70 Challenger, a lot of C1 and C2 Corvettes as well as a host of Tri5s and A-bodies. Since we offer 4 different widths ranging from 55.5" to 61.5", we can fit an IRS under just about any project you have going. Whether it is just the IRS cradle to graft into an existing chassis, rear subframe or complete chassis, we can offer it in just about any configuration that would work best for you.

In addition to our IRS, we also are proud to announce the introduction of our '59-'64 Impala/full-size chassis. This is something that has been in the works for quite some time now, and it was a very challenging undertaking to create something that would maximize the amount of factory floor pan that could still



We're honored that the National Street Rod Association named our Multilink IRS their "New Product of the Year" at the 2014 NSRA Street Rod Nationals in Louisville, KY. This product has proven to be a popular means of improving both handling and the ride quality of a rod or custom.

be used. It has been a lot of work, but we have created something that will deliver the ride and drive quality that we are looking for, without needing a massive amount of floor modifications. Because we know that these cars look fantastic slammed, we have also created a new front and rear air spring suspension system so you can dump the car "in the weeds" and still have a great ride. If air springs aren't your thing, we can offer this chassis with our IRS or a 9" with the proven triangulated 4-bar and coil-over suspension. All three options are light years ahead of the original chassis/suspension combination and will be a great foundation to your '59-'64 project.

Ever since January of 2013 we have experienced growth on an unprecedented level. Even though the economy hasn't

MORRISON

2





Matt Jones' recognizable 1969 Camaro was fitted with the prototype AME Multilink IRS and has driven many thousands of miles with this system. The car is now being used to benchmark and test out new components that we look forward to release soon.

fully recovered, it appears that people want to get their hot rod or muscle car projects underway. To keep up with the new level of demand, we have done a lot around the shop. New machinery has been purchased, jig tables have been rearranged for a more logical flow and we have hired many new skilled craftsmen. While it does take a little time to get new guys in the shop up to speed, the amazing team we have assembled is turning out

through the various stages of Manufacturing to Assembly and finally Shipping, our sales and tech staff will be able to locate your order and tell you exactly where it is in this process. While this tracking system is going to be great at keeping you informed on the progress of your order, it will also help us to locate potential bottle-necks in our processes, allowing us to become more efficient and deliver your chassis in a much more timely fashion.



chassis and subframes at a pace that we have never done before. Even though we are producing more, we are also selling more. Lead times have lengthened a bit, but rest assured we are doing everything we can to reduce the wait from the time your order is placed to the time you receive your chassis.

One of the big investments we have made this year is a bar code tracking system to keep you informed of your project's progress. This internal system is going to track the progress of every chassis, subframe or rear end housing we manufacture. When an order is generated for a chassis, subframe or housing, it will be assigned a bar code sticker. As the project progresses from Engineering

As always, we owe you a debt of gratitude and a heartfelt "thank you". If it wasn't for your support and business we wouldn't be where we are today. As a result of all the varied projects we take on, we are constantly on the cutting edge of suspension design and chassis technology. As we enter our 44th year of business we take pride in providing you with the best chassis components and engineering this market has to offer. Your business is valued and our staff welcomes your comments as to how we can provide you with better parts and service. Whether it is an idea for a new product or thoughts on improving what we have, please let us know. Your support is appreciated and please keep us in mind for your next project. Thank you!

Table of Contents

3-Link Rear Clip	32,33
4-Bar Clips & Suspension	32,35
4-Link Clips & Suspension	32,37
Air Spring Suspension	28,32,36,43
Apparel	66
Axles	52
Bikini Clip (front)	46
Bumper-To-Bumper Frames	6-29
Brackets	50,54,57,64
Brakes & Master Cylinder	52-54
C1 Chassis	11-13
Center Frame Kit	31,46
Cleco Kits	65
Crossmembers	31,61-62
Coil-Over Shocks	47,48
Diagonal Links	39
Driveshaft Loops	61
Dzus Fittings	57
Frame Connectors	61
Frame Rails	30
Front Clips & Suspension	19,21,40-46
GT Sport Chassis	6-18
GT Sport Clip, Camaro	19-21
Housings	49
Ladder Bar Clips & Suspension	38
MaxG Chassis	22,23
Morse Cables	58
Motor Plates	60
Outriggers	31
Panhard Bars	39
Quick Release Pins	64
Rack & Pinion	59
Rear Clips	20,32-38
Rear Multilink Suspension	4-5
Rear Spring Kit	47
Rod Ends	25,63
Roll Bars & Cages	55,56
Shock Absorbers	47,48
Springs	50
Steering Components	58-59
Tools	65
Tri 4-Bar Clips & Suspension	34
Tri-5 Chassis	6-8
Truck Chassis	16-17,27,44
Tubing	61
Tubing 90° Bends	31
Videos	68
Wheel Tubs	20,57
Weld-In Crossmember Kits	31,44-46,61-62
Wilwood Pro Spindle	47

ABOUT THE COVER

11-time SCCA Solo National Champion Mary Pozzi's new 2nd Gen Camaro features an AME Multilink IRS and companion AME IFS. The "hugger orange" machine dominated Super Chevy magazine's 2014 Suspension Challenge. Photo by Cesar Andre.



AME Multilink

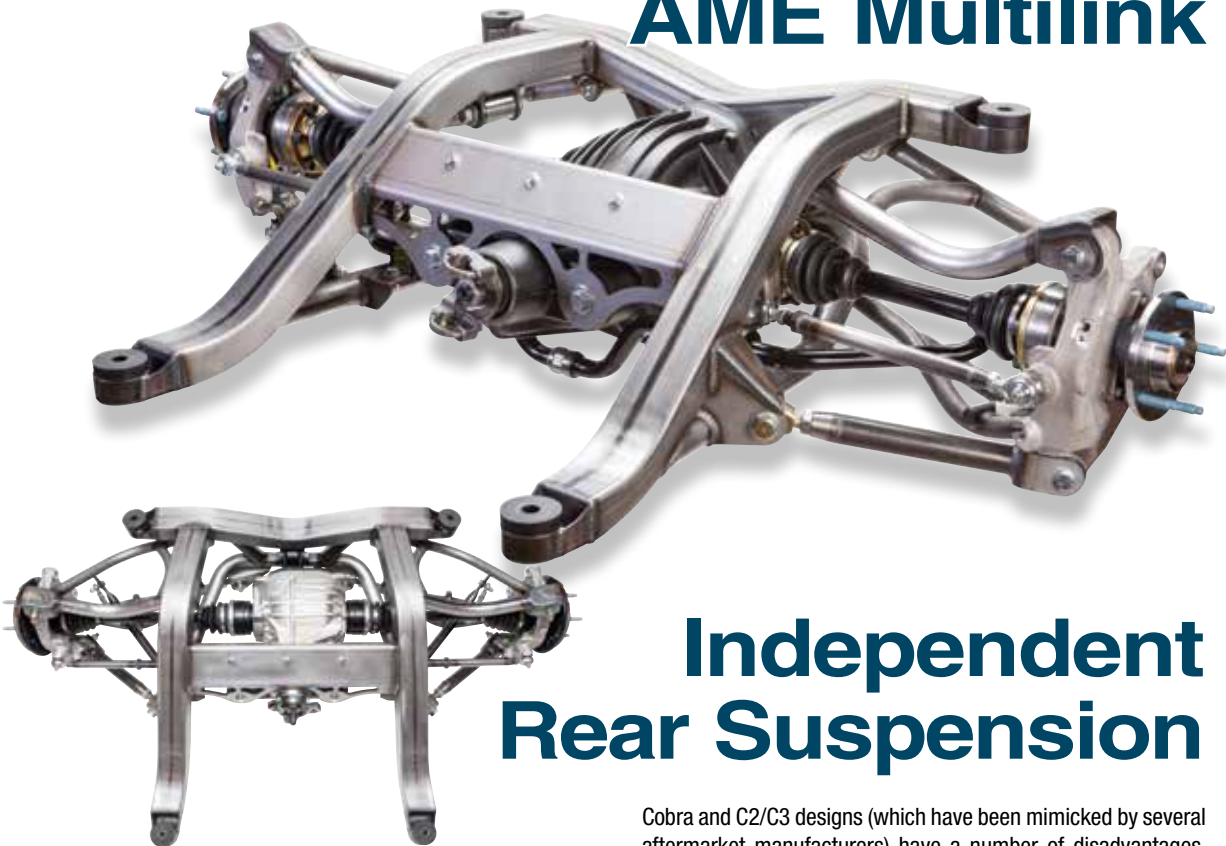

Independent Rear Suspension

When asked to evaluate the handling of Matt Jones' Multilink IRS-equipped 1969 Camaro, which was entered in the Super Chevy magazine Suspension Challenge, test driver Mary Pozzi—an 11-time SCCA Autocross Champion—summed it all up by saying “This is THE BEST suspension I’ve ever felt underneath a car on a track.” That’s a strong testimonial from a highly credentialed professional.

It’s important to understand that not all Independent Rear Suspensions are the same. Early IRS setups, typified by Jaguar,

Cobra and C2/C3 designs (which have been mimicked by several aftermarket manufacturers) have a number of disadvantages. These include poor toe and camber control, little anti-squat and spindle support, limited wheel offsets and requiring a relatively large “package.” They also have horsepower limitations.

The Morrison Multilink IRS can trace its design lineage to a number of the world’s most renown “exotics” that include late model Ferrari, BMW, Porsche, and Nissan GT-R automobiles.

There are a number of important advantages to the new Morrison Multilink IRS; all of which add up to optimum handling and long-term dependability.

INSTALLATION INFORMATION

- Available in four track widths: 55.5", 57.5", 59.5" and 61.5" (wheel mounting surface to surface width)
- Wide variety of gear ratios: A half-dozen ratios between 3.54 and 5.13
- Brake options: 12.4" rotor with floating caliper, Wilwood 14.3" with W6A caliper or 14.4" with OEM Brembo caliper.
- Minimum wheel size: 17"* with 12.4" brake rotors, 18" with Wilwood brakes.

** Only certain wheels will work. Please call for details.*



MORRISON



800-929-7188 • fax: 253-922-8847 • www.artmorrison.com

IRS Technical Features & Benefits



Functionally Independent Design

The decoupled links allow changes to one parameter without affecting others. For example, during the design phase we were able to make an adjustment to the camber curve with little or no effect on the roll center. This gives you the freedom to set the car up for optimal handling under varying conditions.

Direct Load Paths

Through use of decoupled lower links a direct load path is created that prevents control arm failure. Moreover, most bushings are loaded in their radial direction for maximum stiffness.

Superior Knuckle Support

Typical wishbone designs attach at three points in single shear. The Morrison Multilink IRS has four attachment points to control freedom of movement, three of which are double-shear attachments.

Improved Wheel Control

With the AME Multilink IRS you can establish functionally independent camber, caster and toe curves. Moreover, critical toe link locations can be tuned to allow dynamic steering while maintaining stability in high bump situations. For example, you can have up to 1° toe at max bump travel. The minimized link deflection and high durometer bushings help maintain precise wheel alignment.

Ride Quality Improvements

Unsprung vehicle weight is reduced by approximately 100 lbs., requiring less spring rate to control wheel movement. NVH (noise/vibration/harshness) is reduced because it must travel through three sets of bushings before reaching the driver's compartment.

Unique Cradle Design

Not only does this facilitate installation of the Multilink IRS in most Morrison GT Sport chassis, but makes it easily adaptable to other vehicles. It can be aligned to the vehicle during installation and provides excellent serviceability. Loads from the coil-overs transfer to the vehicle frame, not the suspension cradle.



MORRISON

PERFORMANCE
AM
QUALITY

5

800-929-7188 • fax: 253-922-8847 • www.artmorrison.com



Give Any Tri-5 Chevy Sports Car Handling!

Simply replace the 50-plus year-old chassis with Art Morrison's computer-designed "GT Sport" package!

It's been over a thousand GT Sport chassis ago that our "Project GT55" debuted to rave reviews and literally helped fuel the "resto mod movement." The concept of taking a classic design like the Tri-5 Chevy and giving it superior handling, an improved ride, and a contemporary stance has certainly resonated with a large number of enthusiasts. Our "Project GT55," which was equipped with a healthy 530 horsepower SBC crate motor and T-56 6-speed tranny, was initially put through its paces by the editors of Super Chevy magazine and recorded impressive numbers in acceleration, braking, skid pad and slalom that put many exotic sports cars to shame.

Now we've made a good thing even better. We started up front, developing the "Sport IFS" front suspension package. It features more aggressive geometry, heavy-duty control arms and larger polyurethane bushings. Benefits include improved high

speed stability, the ability to run larger front tires, minimized nose-diving in hard braking and better overall handling.

The latest development is the availability of our remarkable new Multilink I.R.S. in Tri-5 GT Sport chassis. This attribute clearly optimizes the handling characteristics of any "shoebox" Chevy and leaves nothing on the table.

Of course, the fundamental beauty of the AME GT Sport chassis is that it's a virtual "bolt-on" installation. You can literally unbolt the body from the OEM frame and slide a GT Sport chassis into place. While many of the nation's top pro builders use GT Sport chassis, many do-it-yourselfers have successfully installed them.

Whatever your performance goals are, AME can configure a GT Sport chassis to meet those needs. Let our tech consultants help you achieve those goals.

CHASSIS WITH SUSPENSION: \$13,518.00
COMPLETE CHASSIS: \$16,478.00



Make a good thing even better by equipping your Tri-5 with the new AME Multilink IRS. It's an available option that will set your ride apart from others. It's much quieter than conventional setups, too.

An Art Morrison GT Sport chassis was selected as the foundation for Street Rodder magazine's 2011 Tour Car. Street Rodder's Jerry Dixey put over 20,000 miles on the car during the course of the year-long promotion, with glowing reports on the car's handling and ride. With over a thousand Tri-5 Chevys now equipped with GT Sport chassis, it has become the standard of excellence for resto-mod projects.

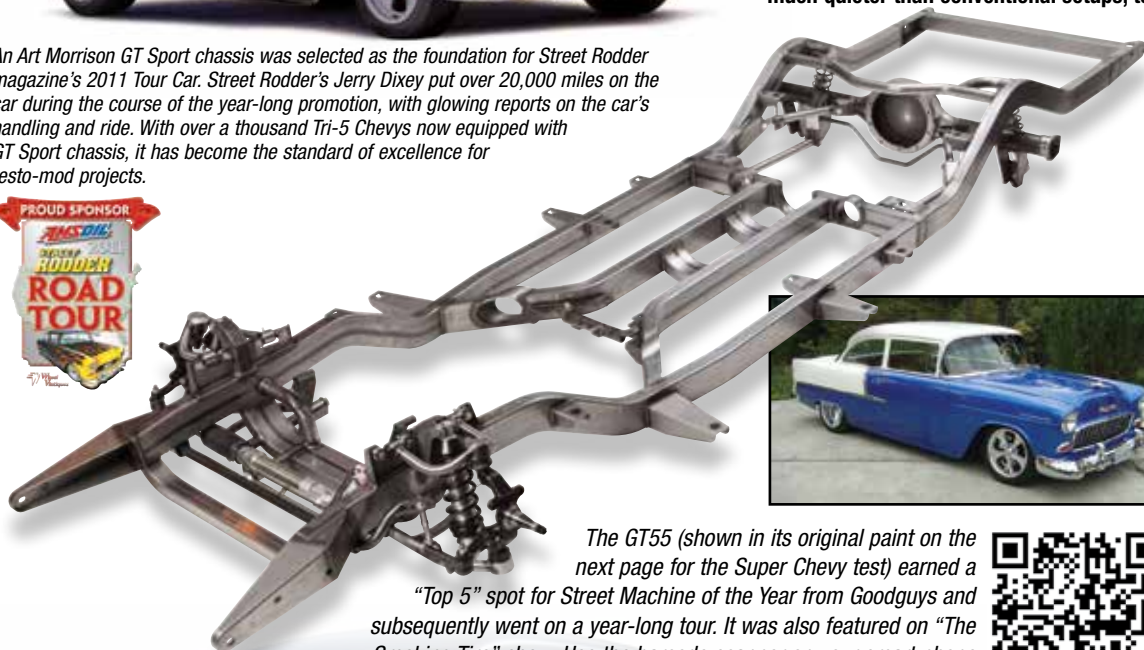

The GT55 (shown in its original paint on the next page for the Super Chevy test) earned a "Top 5" spot for Street Machine of the Year from Goodguys and subsequently went on a year-long tour. It was also featured on "The Smoking Tire" show. Use the barcode scanner on your smart phone and link up to footage with "The Smoking Tire" review of the GT55.



MORRISON

6



800-929-7188 • fax: 253-922-8847 • www.artmorrison.com



Technical Features & Benefits

The AME Tri-5 chassis is designed for optimum roll center stability under all conditions. The roll center is maintained almost perfectly thru the first 3° of body roll and beyond 3° the roll center movement is minimized resulting in a suspension that is vastly improved over a Mustang II type suspension. And the rate of vertical movement is almost 1:1 with suspension movement, while the path it follows during transitions (braking, cornering, acceleration) is very smooth. This results in very consistent, stable and predictable vehicle handling.

Caster

Caster has been increased to +5° (from normal +2°) to provide improved stability at speed. This also improves the tire contact patch and weight distribution under cornering.

Camber Curve & Anti-Dive

Due to the design of the control arm angles, camber control is enhanced throughout the four inches of suspension travel, while minimizing side movement of tire contact patch (side scrub). The side angle of the control arm contributes to increased anti-dive for better stability under hard braking, while serving to provide a smooth and supple ride.

Bumpsteer

The bumpsteer curve has been designed to match camber and caster curves. The vehicle will track straight with minimal steering correction—even on bumpy pavement.

Ride Height

Vehicle will be approximately 3-4 inches lower than stock. To make the vehicle any lower, the recommended method is to use dropped spindles.

Specifications:

Wheelbase: 115 inches

Frame: Mandrel-bent 2"x4" rectangular tubing

Assembly: Fixture welded Finish: Bare metal only.



Multilink IRS Tri-5 Chassis

MORRISON



**GT SPORT
CHASSIS**



Note: Chassis shown with "shipping strut" in place of the normal coil-over shocks.

NEW!



How do you make a good thing even better? In the case of Art Morrison's hugely popular GT Sport chassis for Tri-5 Chevs you equip it with AME's unique Multilink I.R.S.

There are a number of important handling and ride advantages to an independent rear suspension. Probably the most noteworthy is the IRS's ability to compensate for bumps and irregularities in the road (or track) and maintain the tire's vertical axis perpendicular to it. The net result is an optimum "contact patch" for both right and left tires. And the semi-active steering components increases cornering performance for autocross, track day and canyon carving.

The IRS has also proven to be much quieter than a conventional "live" axle setup —transferring far less "road noise" to the chassis. It's added comfort is ideal for long drives and is ideal for coast-to-coast cruising. The overall design of the AME Multilink IRS is quite compact, and therefore minimizes the sheetmetal modifications needed to the trunk pan.

AME's Multilink IRS is based on the Strange Engineering S60 differential, which is capable of handling more than 1400 HP with ease. Bring on the power adders!

Combine this with the proven handling of Morrison's own Independent Front Suspension and you have the makings of the most nimble, sure-footed "shoebox" around.

In addition to improving performance and handling of any "Shoebox Chevy," this IFS/IRS suspension package will significantly enhance the value of the host vehicle. Look at the "hammer prices" of Tri-5 Chevs at leading auctions nationwide and those equipped with Morrison GT Sport chassis bring top dollar.

MORRISON

8



800-929-7188 • fax: 253-922-8847 • www.artmorrison.com



Tri-5 Chassis Accessories



SMALL BLOCK HEADER KIT



IDIDIT STEERING COLUMN



Body Mount Kit

Mounting a Tri-5 body on a Morrison GT-Sport chassis is facilitated with this handy kit, which has the necessary body bushings and stamped components to ensure a secure attachment.

Tri-5 Body Mount Kit From **\$125.00**



LS Engine Mounts

We've developed a highly effective mounting package for LS engines that incorporates Energy Suspension polyurethane bushings, and adapter plate with a positive stop, and OEM-style Chevy mounts. It's easy to use and very secure.

32555740 LS Engine Mnts for GT Sport Chassis . . . **\$240.00**
 32555745 LS Engine Mnts Rubber **\$175.00**

Header Kits

Engineered specifically for small block, big block and Chevy LS engines installed in a Morrison GT Sport chassis. They all feature heavy-gauge tubing and thick 3/8" flanges to assure trouble-free dependability. Ball-style collectors are employed to facilitate leak-free hook-ups to the exhaust system. Prices include header bolts and gaskets. Ceramic-metallic coating is available for an additional **\$410** per pair.

32555831 Small Block Chevy Headers with 1-3/4" Primaries & a 3" Collector **\$670.00 (pr)**
 32555835 Big Block Chevy Headers with 2" Primaries and a 3" Collector **670.00 (pr)**
 32555833 LS Headers w/1-3/4" Primaries and a 3" Collector (w/O2 Sensors) . . **670.00 (pr)**

We are now a dealer for Ididit Steering Columns. Please call for specific options, pricing and availability.



BIG BLOCK HEADER KIT



LS HEADER KIT



Steering Linkage

This convenient kit contains the components you'll need to connect the DSE power rack to the steering column. Available in polished stainless or bare.

32555860 Steering Link Kit (Bare Metal) **\$210.00**
 32555865 Polished S/S Steering Linkage Kit . . . **350.00**



Housing Breather Kit

Eliminate those pesky leaks that 9" Ford housings are known for. This "catch can" mounts above the housing. Excess pressurized gear oil goes to the tank, is vented, and drains back after parking the car.

40403020 Housing Breather Vent for Hose **\$15.00**
 40403030 Housing Vent Tank **45.00**



Brake Line Kits

Here's everything you'll need to "plumb" the brake lines on your GT Sport Tri-5 chassis. Stainless steel is used exclusively for the lines and fittings to assure you of total long-term reliability. Use in conjunction with our Master Cylinder kit.

32555840 Brake Line Kit for GT Sport Chassis **\$645.00**

M/C Adapter & Line Kit

Adapter fits you mount a tandem-style dual reservoir Master Cylinder to the firewall, and allows use of the stock Chevy pedal assembly (and the OEM ratio). The line kit lets you plumb the tandem M/C into the brake system.

32555811 M/C Adapter for Tri-5 Chevy **\$15.00**
 32555856 M/C-to-Chassis Brake Line Kit **\$80.00**

MORRISON



What Our Customers Say...



"Art Morrison has been the chassis of choice for Karl Performance for a number of years. We feel this is the best chassis option in the market, and helps us produce a quality finished product that is second to none!"

Carl Moyer
Karl Performance
Des Moines, IA
Chassis #437

"Wanting only the best for this build, it began with a Morrison chassis purchased thru Thunder Valley Custom's. As a 2014 Detroit Autorama 'Great 8' Ridler Contender, we believe it's safe to say we 'nailed' it with the end results...and what a ride when hammering it!"

Dan Duffy
Marietta, Georgia
Chassis #835



"It's our opinion every tri five build should be based on an AME chassis. Our cost comparisons show that modifying an original chassis just doesn't make sense. Cost aside the secure feeling you get while driving is worth it alone."

Jon Mannila
MetalWorks Classic Auto Restoration
& Performance Center
Eugene, Or
Chassis #1000



"The Morrison team did an excellent job on the Chassis for the Mo' Muscle Built '57 Chevy. The vehicle has over 6,000 miles and counting and the ride has been great!! When it comes to Tri-5 Chassis, Art Morrison Enterprises is second to none!"

Blake Meaux
Mo' Muscle Cars
Conroe, TX
Chassis #589



MORRISON

10



800-929-7188 • fax: 253-922-8847 • www.artmorrison.com

Get State-Of-The-Art Handling For Your 1953-1962 Corvette!



Following the very successful launch of our GT Sport chassis for 1955-57 Chevys, AME's engineering staff focused its attention on the First Generation Corvette. While the classic styling of 1953-62 'Vettes has legions of admirers, the car's notoriously harsh ride and dubious handling characteristics have prevented enthusiasts from enjoying a driving experience in a manner that owners of C5 and C6 Corvettes have come to expect. In addition to providing a phenomenal "bolt on" improvement for

those First Generation Corvette owners willing to step up, this latest addition to Art Morrison's GT Sport Chassis line provides an excellent foundation for anyone wanting to build a classic Corvette-bodied "kit car." There are a number of 1953-55, 1956-57 and 1958-62 style bodies on the market that would lend themselves well to this particular application.

The first chassis off the production line became the foundation for Art Morrison's "Project 3G" 1960 Corvette, which won several important construction awards and

raised the bar in performance through a series of tests conducted by leading automotive publications. With an average of 1.05 Gs on the skid pad, a 116-foot braking distance from 60 mph and quarter mile times in the low 12s at over 120 mph, the car exceeded a "G" in each of the measured performance criteria.

Subsequently, many other 1st generation Corvettes have been given a new lease on life with a Morrison GT-Sport chassis. It's a project that is well within the scope of any competent do-it-yourself builder.

Use the barcode scanner on your smart phone to see The Smoking Tire review of the 3G Corvette.

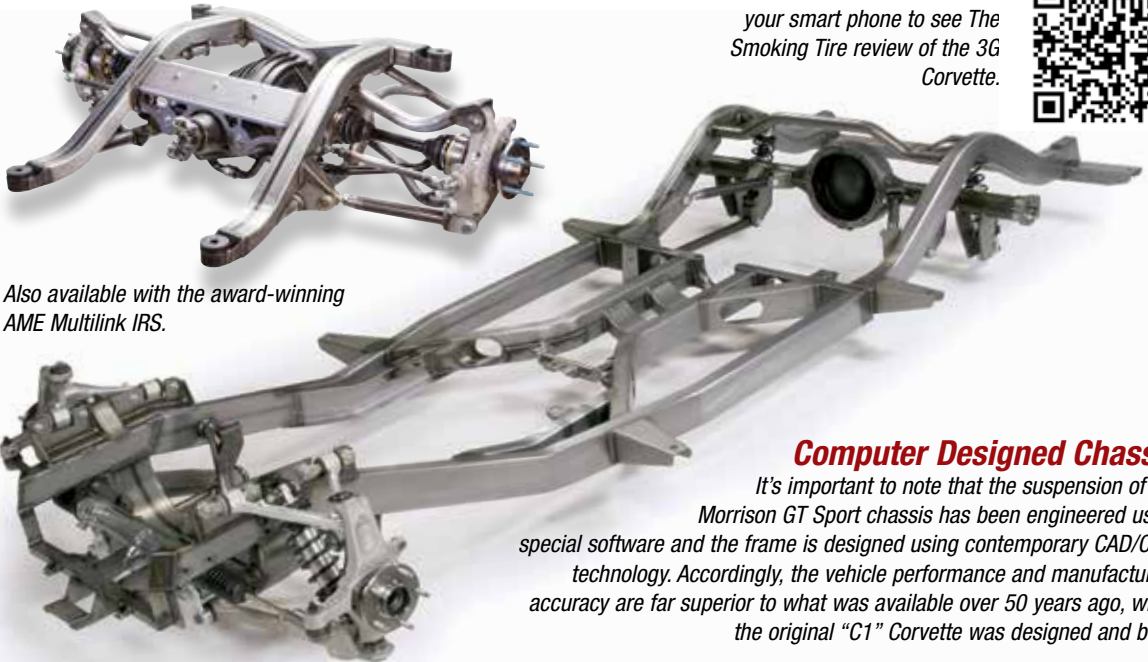

Also available with the award-winning AME Multilink IRS.

Computer Designed Chassis

It's important to note that the suspension of the Morrison GT Sport chassis has been engineered using special software and the frame is designed using contemporary CAD/CAM technology. Accordingly, the vehicle performance and manufacturing accuracy are far superior to what was available over 50 years ago, when the original "C1" Corvette was designed and built.

BARE CHASSIS: includes welded bumper-to-bumper profile 2"x4" frame, body mounts, bumper mounts, center frame, exhaust holes, core support, engine mount towers, trans x-member brackets. **\$8,275.00**

CHASSIS WITH SUSPENSION: includes bare chassis, C6 Corvette upper and lower control arms and spindles, power rack & pinion, front and rear sway bars, 9" housing triangulated 4-bar links, and Strange adjustable front and rear shocks with springs. **\$14,678.00**

COMPLETE CHASSIS: includes chassis with suspension, C6 13" front disc brake kit, SVO rear disc brake kit, Strange 31-spline axles, center section mounting kit, Strange nodular-iron center section with posi-traction and trans crossmember. Everything you need for a rolling chassis, less tires and wheels. **\$18,053.00**

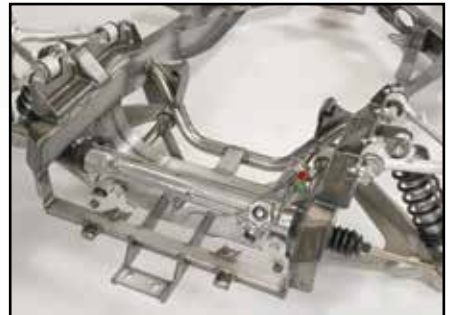

How AME's Engineering Team Obtained Great Handling Improvements For "C1" Corvettes...

Corvette I.F.S. Components

The first step in obtaining vastly improved handling was to employ the forged aluminum control arms and spindles from 2005-up Corvettes. In order to take advantage of the C6/C7 Corvette's I.F.S. (which has exceptional geometry in stock form), several revisions were required to fit under the narrower 1953-62 Corvette body.

Track Width

While the C6's hub-to-hub track width was narrowed, AME's Engineering Department slightly increased the scrub radius over the C6's very small amount. Accordingly, when 9-inch wide rims (with 6.5" back-spacing) are employed, an excellent balance is achieved between steering feedback and driving performance. Through reducing the wheel's offset, it is also possible to fit the car with larger, high performance brake calipers.

Camber Angle & Roll Center

The Front View Swing Arm (FVSA) length has been shortened to better maintain camber angle while cornering. At the same time, the static roll center height was reduced to minimize side scrub and jacking force. As a result, straight line stability and ride quality have been enhanced.

Caster Angle

Static caster has been reduced to +6° to promote a crisper steering "feel" and to counteract the rise/fall effect of increased scrub radius (as compared to the stock C5 geometry). This also provides an improvement in roll center migration.

Lower CG

By providing through-frame passageways for the exhaust system, the AME GT Sport chassis for C1 Corvettes allows for a lower stance, while maintaining the necessary ground clearance. This enables the vehicle to have a lower Center of Gravity (CG).

Triangulated 4-Bar Suspension

A major difference between the Morrison GT Sport chassis for the 1953-62 Corvette and C6 'Vette is the use of a special triangulated 4-bar rear suspension instead of an I.R.S. There are several reasons for this—not the least of which is the track width of the C6 unit. The triangulated 4-bar setup performs well in terms of acceleration control and provides excellent lateral stability.

Breaking the Triple 1-G Barrier

Our Engineering Department has done in-depth calculations and determined that with the proper combination of power, tires and brakes, a Morrison GT Sport chassis-equipped C1 Corvette should be able to exceed 1-G force on the skid pad, in acceleration, and braking. Our Project 3G 'Vette has done it!

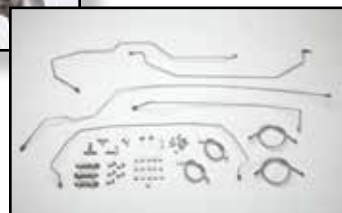
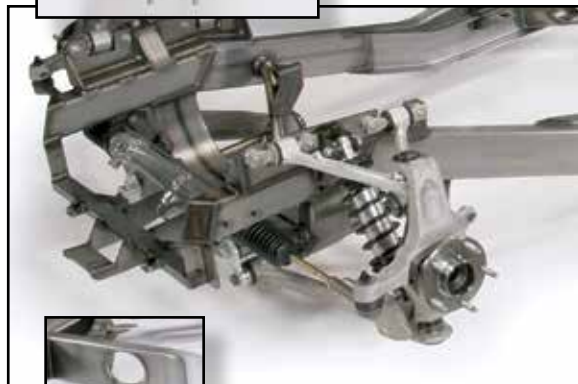

C1 'Vette GT Sport Chassis With AME Sport IFS

Also available with the award-winning AME Multilink IRS.



Due to popular demand, we have developed another GT Sport chassis for the First Generation Corvette; one that uses an AME Sport IFS front suspension with a Wilwood spindle instead of C6 Corvette components and facilitates the use of front wheels with diameters down to 15".

Like our original GT Sport chassis, you can simply unbolt the stock 1953-62 Corvette chassis, roll it away, and replace the ancient technology with 21st Century dynamics. Moreover, you can easily upgrade to LS power and most any popular standard shift or automatic transmission.

The Sport IFS is augmented by Strange adjustable coil-over shocks and an adjustable anti-sway bar, while it also utilizes a power rack & pinion steering. This makes for nimble, sure-footed handling that's a quantum improvement over stock.

A triangulated 4-bar rear suspension with a 9" rear end can handle an abundance of power while also providing excellent lateral support. Suspension comes courtesy of Strange adjustable coil-over shocks, with further ride fine tuning possible with an AME adjustable anti-sway bar.

Special passageways for the exhaust are built into the frame, which allows for a lower CG and ample clearance. This also facilitates a lower stance. The crossmembers also serve to stiffen the chassis, which significantly improves handling.

Extensive engineering and suspension analysis confirms that the performance of this new C1 chassis is on an even par with our original GT Sport chassis with C6 components. Given the proper amount of horsepower, big brakes and a good set of high performance tires, it's quite possible to achieve 1+Gs in acceleration, braking and the skid pad.

BARE CHASSIS: Includes welded bumper-to-bumper profile 2"x4" frame, body mounts, bumper mounts, center frame, exhaust holes, core support, engine mount towers, trans x-member brackets. **\$8,275.00**



CHASSIS WITH SUSPENSION: Chassis, Sport IFS control arms, Wilwood Pro spindles, Strange adjustable coil-overs, springs, rack & pinion steering, 9" housing and triangulated 4-bar suspension, adjustable front & rear anti-sway bars. **\$13,598.00**

COMPLETE CHASSIS: Chassis with suspension, front disc brake kit, SVO rear disc brake kit, Strange Engineering 3rd member, Strange Engineering 31-spline axles. **\$16,558.00**



It's Easy To Update Any 1949-'54 Chevy With An AME GT Sport Chassis

MORRISON



GT SPORT CHASSIS



Tim Diver Street Rods 1954 Chevy



Photo By Source Interlink Media



Use the barcode scanner on your smart phone to see Streetfire video of the ICON built '52 Chevy.

An increasingly popular "family" of vehicles to benefit from an Art Morrison GT-Sport chassis is the venerable 1949-54 Chevy. But it's important to tell you how we got there. Our first GT Sport chassis were CAD engineered, but all the data on the base frame rails was accumulated via physical measurements. Not so this latest masterpiece. A remarkable device called a "Faro Arm" which literally "traced" every square inch of the OEM Chevrolet frame was employed to directly transmit X-Y-Z data directly into the computer. This eliminates any chance of human error, and guarantees that the body of your 1949-54 Chevrolet will fit superbly.

Once the basic parameters were obtained, Morrison's engineering staff went about designing a front and rear suspension package that would deliver the handling and ride that has made the original GT-Sport chassis for Tri-5 Chevys the unquestioned industry leader. With almost 900 of these

chassis in use as of this writing, there is a strong foundation to build on.

Up front, Morrison's engineering team has developed a sophisticated Independent Front Suspension (IFS) that employs tubular steel control arms, adjustable coil-over shocks, a beefy sway bar and Wilwood front spindles. A power rack & pinion (20:1 ratio) handles the steering.

Since most builders will want to have something more potent than the original 6-cylinder "stovebolt" engine, the chassis will also have motor mounts for the popular small block V8, or the new LS-series powerplants. Likewise, a wide variety of manual and automatic transmissions can be employed, including Powerglide, TH350, TH400 and 700R4 automatics, plus any 4-speed, Tremec TKO and T-56 6-speed, as well as Richmond 5 or 6-speed manual transmissions.

The rear suspension is AME's highly regarded triangulated 4-bar setup, which

gives excellent straight-line and lateral control. Strange Engineering adjustable coil-over shocks and a sway bar complete the package.

With a wide variety of body styles that this chassis will work with, including the unique "fastback" sedans and elegant Bel Air hardtops, let your imagination take over!

CHASSIS WITH SUSPENSION: Includes frame, with 3" exhaust hole, uncoated upper and lower control arms, spindles, power rack & pinion, front and rear sway bars, 9" housing, triangulated 4-bar links and Strange adjustable front and rear coil-over shocks with springs. **\$13,598.00**

COMPLETE CHASSIS: Includes chassis with suspension, front disc brake kit, SVO rear disc brake kit, Strange 31-spline axles, center section mounting kit, Strange nodular iron center section with Positraction. It's a rolling chassis, less tires and wheels. **\$16,558.00**



When the engineering team at Art Morrison Enterprises set about designing a GT Sport chassis for 1949-54 Chevrolets they employed the characteristics of AME's highly successful Tri-5 chassis. It is exceptionally stable, corners hard without appreciable lean, won't "dive" under braking, and has a great ride.

MORRISON



14

800-929-7188 • fax: 253-922-8847 • www.artmorrison.com





GT-Sport Chassis For 1964-1972 A-Bodies

Morrison's engineering team proudly introduces a GT-Sport chassis for the 1964-72 Chevelle. The biggest challenge faced by AME's designers was to place the chassis as far under the body as possible to reduce the amount of frame visible from under the car. They developed a unique inner-angled frame rail that tucks right under the floor pan. This provides an increase in ground clearance, which allows for a lower stance. And, as you know, lowering the CG of a vehicle improves its handling.

Another key to better handling is a stiff chassis, and to this extent AME engineers are focusing on increased torsional rigidity. Stiffening the chassis does not by itself make for a harsh ride. You should know that the suspension provides an optimum balance of handling and comfort. Our goal is to provide Chevelle owners with a great overall ride, while still providing exceptional corner-carving ability.

Extensive development work on the

suspension package has resulted in optimizing various parameters (camber angle, roll center, caster angle, CG, etc.) and the creation of suspension components that will deliver optimum handling, ride and "0" bump steer.

CHASSIS WITH SUSPENSION:

Includes Sport IFS control arms, C6 knuckles, bearings and hubs, Strange adjustable shocks with springs, front and rear sway bars, power rack and pinion, triangulated 4-bar links and 9" housing.

\$14,883.00

COMPLETE CHASSIS:

Includes chassis with suspension, C6 Corvette front disc brake kit, SVO rear disc brake kit, Strange S/S street axles, center section mounting kit, Strange S-series

center section and transmission mount. Everything you need for a rolling chassis, less tires and wheels. **\$18,238.00**



G3 Rods 1969 Pontiac GTO

Photo By: Now Box Photography

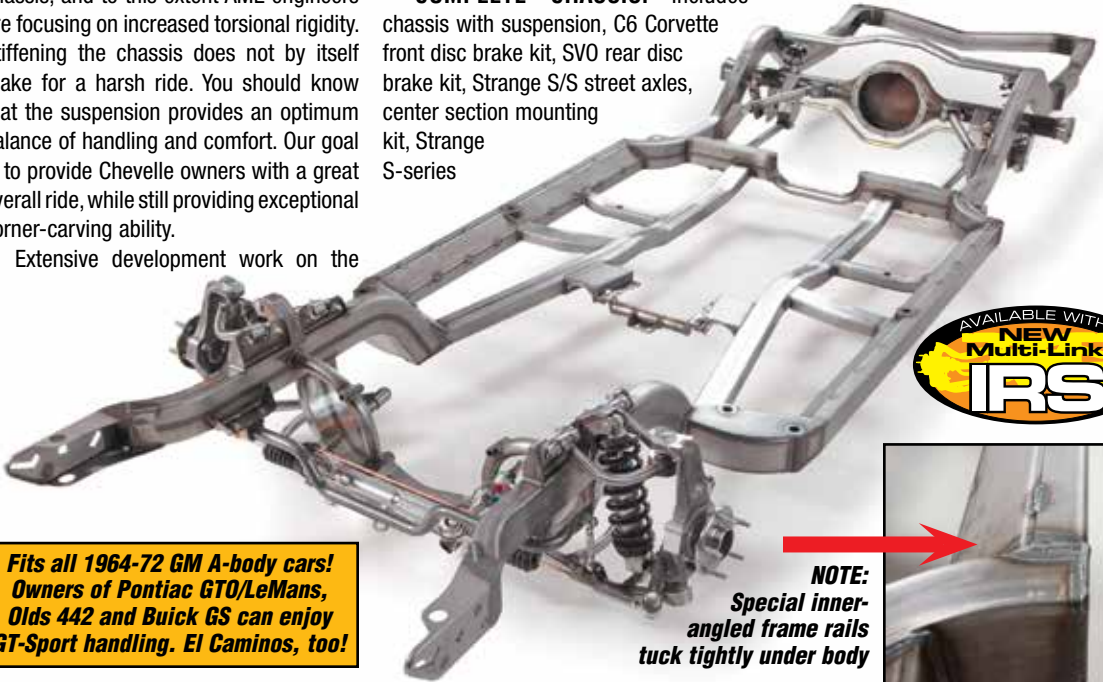

Fits all 1964-72 GM A-body cars! Owners of Pontiac GTO/LeMans, Olds 442 and Buick GS can enjoy GT-Sport handling. El Caminos, too!

NOTE:
Special inner-angled frame rails tuck tightly under body



MORRISON



15

800-929-7188 • fax: 253-922-8847 • www.artmorrison.com

1947-53 GM Truck Chassis

High Performance Handling Edition

MORRISON



GT SPORT
CHASSIS

1950 Farm Truck



2x6
Main Rails



Use the barcode scanner
on your smart phone to
see Farm Truck Video



If you're looking to build a "sleeper," Art Morrison's new GT Sport chassis for 1947-53 Chevrolet pickup trucks is the key. Imagine having a 60-plus year-old truck that handles like a new Corvette. Our patina-highlighted "Farm Truck" caused more than a few jaws to drop performance pad testing for a *Custom Classic Trucks* story.

The "High Performance" version of this chassis features a "Sport" independent front suspension with beefy 1 5/16" diameter upper control arms and upsized poly-bushed rod ends that combines with coil-over shocks and anti-sway bar (both adjustable) to provide exact handling. It's also available with an Air Spring+Plus suspension package.

As you can tell by the "Farm Truck" photo, the ride height is quite low and requires the bed floor to be raised about two inches. The rugged 2x6 frame is designed to "tuck in" the exhaust system for optimum ground clearance. A 4-bar rear suspension with "Johnny Joint" rod ends and a Panhard bar provide perfect anchors for the reinforced 9" rear.

Like all other Morrison GT Sport chassis, all required body mounts, core supports and bumper mounts are included to provide a virtual "bolt on" build. It can accommodate virtually any V-8 engine/transmission (stick or automatic) combination. A optional pedal mount makes for a clean installation. Truly, the High Performance AME GT Sport chassis represents a superb investment in fun driving and overall value.

BARE CHASSIS: Includes welded bumper-to-bumper 2"x6" frame, body mounts, bumper mounts, exhaust notches, core support, engine mount towers, trans x-member brackets. **\$7,160.00**

CHASSIS WITH SUSPENSION: Chassis, Sport IFS control arms, 2" dropped Wilwood PRO Spindles, Strange adjustable coil overs, springs, rack & pinion steering, 9" housing, parallel 4-bar tubes with Johnny-Joint ends, rear mounted panhard bar, adjustable front & rear anti-sway bars. **\$13,263.00**

COMPLETE CHASSIS: Chassis w/suspension, front disc brake kit, SVO rear disc brake kit, Strange Engineering 3rd member, Strange Engineering 31-spline axles. **\$16,223.00**



MORRISON

16



800-929-7188 • fax: 253-922-8847 • www.artmorrison.com

1947-53 GM Truck Chassis

Economical "Standard" Configuration

MORRISON



GT SPORT
CHASSIS



Thriftmaster by ICON



2x6
Main Rails

It's tough to call this chassis "Standard," as it provides a quantum leap in ride and handling over the OEM Chevrolet setup. The primary difference between this and the "High Performance" GT Sport chassis shown on the previous page is that it employs an independent front suspension designed more for relaxed street use. Other differences include the use of poly-bushed stainless steel rod ends in the 4-bar rear suspension (instead of "Johnny Joints") and a rear frame configuration that allows the bed to be left stock. The ride height is also a bit higher than the "High Performance" version.

Because of these subtle differences, we've been able to lower the price of the "Standard" chassis, making it a more affordable build. It's ideally suited to the custom classic truck enthusiasts who wants nimble handling and a great ride—but isn't looking to shave a few seconds from their lap times at Track Day!

The beefy 2x6 main rails and strategically placed crossmembers serve to provide a solid foundation for any engine and transmission combination, with adjustable coil-overs on all four corners and an anti-sway bar complimenting the IFS, it's easy to get the perfect balance of performance and comfort. For the "traditionalist," a leaf spring rear suspension is an available option.

A power rack & pinion makes steering a breeze, and the beefy braced 9" rear end can be fitted with a wide range of ring & pinion gears to optimize your drivetrain. This is the new "standard" by which all others will be judged.

BARE CHASSIS: Includes welded bumper-to-bumper 2"x6" frame, body mounts, bumper mounts, exhaust notches, core support, engine mount towers, trans x-member brackets. **\$6,565.00**

CHASSIS WITH SUSPENSION: Chassis, IFS control arms, 2" dropped Wilwood PRO Spindles, Strange adjustable coil overs, springs, rack & pinion steering, 9" housing, parallel 4-bar tubes, rear mounted panhard bar, front anti-sway bar **\$11,683.00**

COMPLETE CHASSIS: Chassis w/suspension, front disc brake kit, SVO rear disc brake kit, Strange Engineering 3rd member, Strange Engineering 31-spline axles **\$14,643.00**



MORRISON



17

1959-64 Chevrolet Chassis

The Perfect Solution For Obtaining An Exceptional Ride, Superior Handling And A Low Stance.

MORRISON



GT SPORT CHASSIS

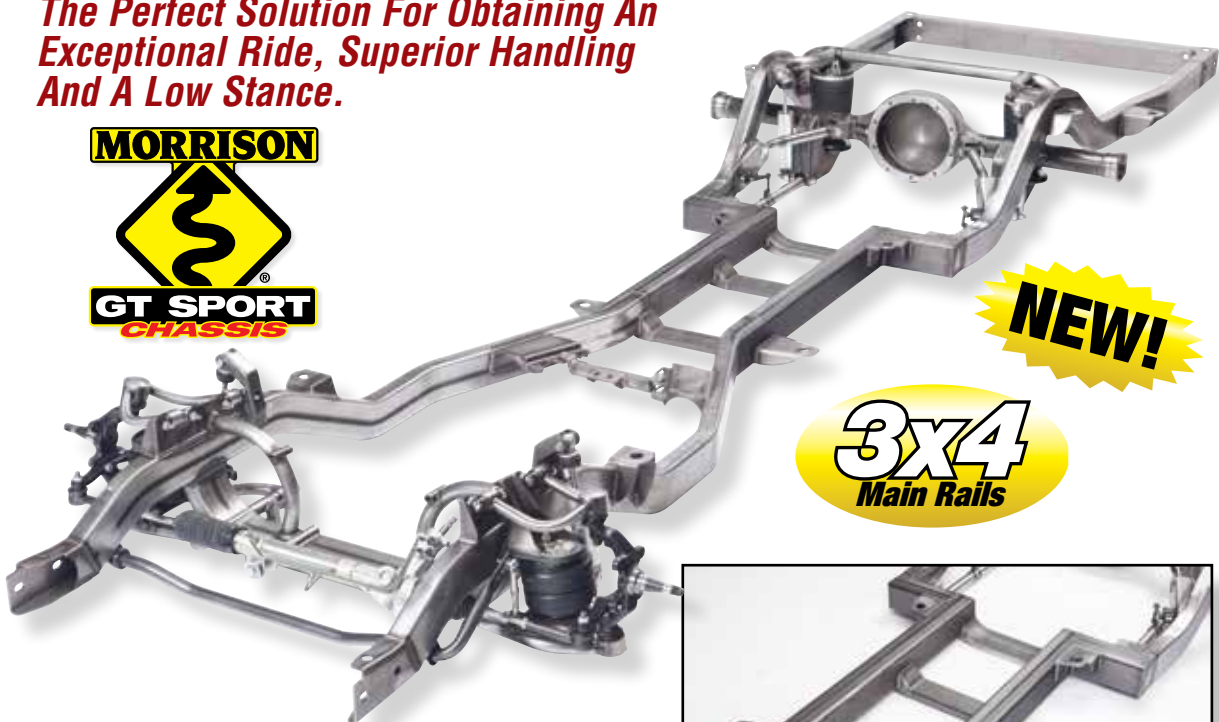

NEW!

3x4
Main Rails

The engineering team at Art Morrison Enterprises has focused their talents on the increasingly popular 1959-64 Chevrolets and developed an innovative chassis that provides a low ride height and great handling. What's more, this new AME GT Sport chassis features beefy 3x4 main framersails and specially designed crossmembers that provide ample clearance for the exhaust system.

Up front you'll find AME's highly acclaimed Sport IFS with its beefy tubular control arms, Strange adjustable coil-over shocks, Wilwood spindles, an adjustable anti-sway bar and a power rack & pinion steering. Motor mounts are available for small block, big block, W block (348-409) and LS-series engines. Transmission mounts can be configured for most any popular automatic or manual shift tranny.

Superior handling—and the ability to handle an abundance of power—is assured through a triangulated 4-bar rear suspension and a beefy 9" rear end. Adjustable coil-overs and an adjustable anti-sway bar provide the desired ride. A new 2-piece driveshaft greatly reduces vibration and minimizes floorboard modifications. In fact, the GT Sport requires less floor mods than any aftermarket chassis for these cars.

Available with a Performance Air Spring suspension, coil-overs, or our exclusive Multilink I.R.S. for optimum handling.



MORRISON

18



800-929-7188 • fax: 253-922-8847 • www.artmorrison.com

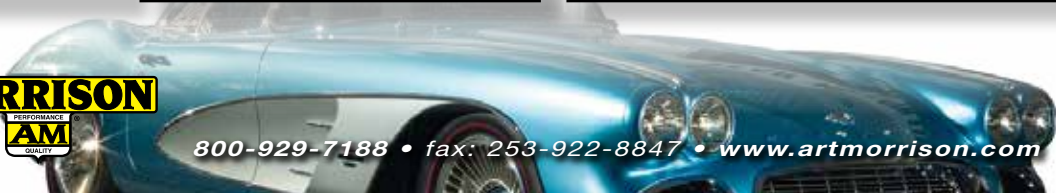

AME GT Sport Front Clip

**Bolt-In Installation For 1967-69 Camaro and Firebird,
1970-81 Camaro/Firebird, plus 1968-74 Chevy Nova**

MORRISON



**GT SPORT
SUBFRAME**

Complete Clip

\$7,139



Use the barcode scanner on your smart phone to see *The Break-Down episode of the Camaro.*

Destined to become one of the most popular bolt-in chassis modifications of all time, Morrison's new GT-Sport Front Clip is a "must have" addition to any first generation Camaro/Firebird built to G-machine specs. It also fits 1968-74 Chevy Novas.

Through use of a specially modified C6 spindle with lowered steering arm mounting, the power rack & pinion steering unit is mounted some 2" lower in the frame, which allows for a lower CG and improved handling. Big block, small block and LS-series Chevy engines can be employed, as well as virtually any popular automatic or manual transmission—including Richmond 5/6-speeds, Tremec T56 and TKO, Muncie, Powerglide, TH-350 & 400, 700-R4 and 4L60E—thanks to a series of available mounts.

Designed through use of FEA (finite element analysis) the 105 lb. front clip has outstanding strength and stiffness, yet is significantly lighter than the bulky OEM unit. With a reduced unsprung weight, forged aluminum C7 Corvette control arms, a shortened front view swing arm, modified caster, and adjustable coil-over shocks, Morrison's GT-Sport clip will provide awesome handling. It comes with a near-stock tread width for optimum wheel fitment opportunities, and can use a wider-than-stock tire (265/35R18 tested).

As no cutting or welding is required, installing a GT-Sport clip can be performed by most competent do-it-yourselfers in the comfort of their own garage. With an aggressive, lower stance and incredible handling characteristics, the look and "feel" of a Morrison GT-Sport Clip-equipped Camaro is unbeatable!

A number of accessories are available to make the installation easier, including body mounts, headers, and a brake line kit.

Bare, Welded Clip	\$3,455.00
C6 Frnt Susp Kit w/Drop'd Arms. . .	2,480.00
Sway Bar & Mount Kit.....	350.00
Tie Rod Ends	80.00
Strange Coil-Overs w/bearings	524.00
DSE Power Rack.....	565.00
Power Rack Fitting Kit.....	40.00
Shim & Alignment Kit.....	145.00
TOTAL.....	7,639.00
Package Discount.....	500.00
Package Price w/o Brakes.....	\$7,139.00



**Bare
Welded Clip
\$3,455**



Many special accessories are available to provide a finishing touch. These include headers, body mount & brake line kits.



AME GT Sport Rear Subframes

Three Highly Effective Rear Suspension Setups For 1967-69 Camaros



3-LINK

As shown
\$5,374

Now you can choose between three highly effective AME GT Sport rear subframes for your 1st Generation Camaro. All employ rugged 2" x 4" mandrel-formed frame rails that are far stronger than flimsy OEM stampings, which makes them better suited to coping with the increased stresses that come with aggressive driving. The subframes are also designed to be used with the stock gas tank.

The primary difference, of course, is what lies between the frame rails. And here's where the choices come into play.

Our popular Tri 4-bar setup offers the advantage of fitting under the stock Camaro floorpan. No modifications are necessary. The triangulated links provide both forward/rearward and lateral bracing for the 9" housing, providing excellent acceleration and handling characteristics.

A more sophisticated setup is offered with AME's track day-proven 3-link package. The forward/rearward housing motion is controlled with three links, while it remains perfectly centered through use of a Watts linkage.

Strange Engineering adjustable coil-over shocks are employed for both the Tri 4-bar and 3-Link subframes, as are special sway bars. They also allow locating the exhaust for optimum ground clearance.

The third choice comes in the form of AME's new Multilink I.R.S. Based on a rugged Strange S60 center section and half-shafts with CV joints, its primary advantage is independently compensating for any bumps or road irregularities to always provide an optimum tire contact patch. With a Morrison Multilink subframe, your Camaro's handling will be second to none.



Now Standard With
Adjustable Swaybars



TRI 4-BAR

As shown
\$4,044



Cut-away view of Morrison's 2"x4" frame vs. OEM stamped rail

2"x4" Welded rear subframe	\$1,960.00
9" Housing with all brackets.....	1000.00
4-Bars w/poly rod ends	410.00
Strange C/O's w/springs, w/bearings	524.00
Lwr c/o mount kit.....	45.00
Sway bar	280.00
TOTAL.....	4,219.00
Package Discount.....	-175.00
Package Price	\$4,044.00

IRS



From
\$11,430

2"x4" Welded rear subframe.....	\$2,390.00
9" Housing with all brackets.....	1,160.00
Watts linkage with poly rod ends	440.00
3-Link bars w/johnny joints	710.00
Strange C/O's w/springs, w/bearings	524.00
Lwr c/o mount kit.....	45.00
Sway Bar	280.00
TOTAL.....	5,549.00
Package Discount.....	-175.00
Package Price	\$5,374.00

67-69 IRS Cradle Rear Clip.....	\$2,020.00
IRS GM 2x3 Cradle Assy. Kit.	8,915.00
JRI Alum. non-adjustable Coil-overs	560.00
Coil-Over springs w/spring Bearings	110.00
GM rotor & caliper kit, 12.4"	400.00
TOTAL.....	11,605.00
Package Discount	-175.00
Package Price	\$11,430.00



MORRISON**GT SPORT****CHASSIS**

Enjoy Optimum Handling In Your 1967-69 Camaro With AME's GT Sport Package

Engineered to use the OEM gas tank, keep the rear bench seat and utilize the stock floorboard



Photo by: Ron Heald from

Spectacular '69 Camaro that uses our front and rear kits. Built by Chris Holstrom Concepts.



Uses C6 Corvette Front Suspension and Triangulated 4-Bar or 3-Link Rear Suspension



While our GT Sport chassis are intended to be true bolt-in bumper-to-bumper units, we've found that because First Generation Camaros came from two different plants, there was enough variation between cars built in Van Nuys, California and Norwood, Ohio to prevent one frame from fitting all. So we've engineered a "3-piece" assembly that allows the builder to position the subframe connectors to best

fit the floor pan of each individual vehicle.

We've combined a C6 Corvette front suspension and triangulated 4-bar rear to provide optimum handling for 1967-69 Camaros. It can also be fitted with a 3-bar rear suspension and Watts linkage. Both setups have undergone extensive testing by leading enthusiast publications and proven to be exceptionally effective.

With the Morrison GT Sport package

you literally have the ability to tightly fit a Camaro body onto this "Frame." You will have to cut a couple "slots" in the factory floorboard and trim the unibody rear rails out to accommodate the chassis and if you use mini-tubs to handle larger rear tires (up to 335) you'll have to trim the some of the rear seat frame. Given the variables, please call AME tech personnel for pricing information.

Key Features Of Morrison's New 3-Piece GT Sport Package

- **Designed as a bolt-in/weld-in for 1967-69 Camaros**
- **Allows use of the OEM fuel tank, rear bench seat and floorboards with minor mods**
- **Use with small block, big block or LS-series engines; most any manual or automatic trans**
- **Mandrel-formed 2"x4" subframes fixture-welded by experienced professionals**
- **Corvette front suspension with forged aluminum control arms**
- **Triangulated 4-bar rear suspension gives both traction control and lateral stability**
- **Optional 3-link rear suspension**
- **Strange Engineering adjustable coil-overs**
- **Run up to 335 rear tires with mini-tub**
- **Uses 20:1 power rack steering**

**MORRISON**

21

800-929-7188 • fax: 253-922-8847 • www.artmorrison.com



Now Available For All Popular Muscle Car Vehicle Applications!

Art Morrison Enterprises makes it easy for anyone to adapt contemporary suspension technology to '60s and '70s Muscle Cars with unibody construction. What we've done here is essentially build a platform upon which a unibody-type vehicle can be "dropped" on. The floorboard of the host vehicle will need to be removed, and a new one fabricated once the body has been mounted to the frame. But in the grand scheme of things, it's far easier than dealing with a separate front clip, rear clip and subframe connectors.

The "Max G" chassis is designed to deliver exceptional performance. You have a choice between tubular steel control

arms or Corvette C6 forged aluminum A-arms up front, with a triangulated 4-bar assembly in the rear. Strange Engineering adjustable coil-over shock absorbers are used on all four corners, and beefy sway-bars employed to control body lean. The total package has proven to be quite effective, and provides both nimble handling and ground-grabbing traction.

Each of these Max G MuscleCar chassis are CAD-engineered for the specific year, make and model car. They are designed to fit the vehicle in such a manner that the

body mounts and core support can easily be fabricated and attached.

If you're contemplating building a first-class performing Camaro, Challenger, Chevelle, 'Cuda, Dart, Demon, GTO, Mustang or ???, a Morrison "Max G" chassis is available for the foundation of your project. When you consider performance and overall ease of construction, it's clearly the way to go!



Rutterz Rodz Chevy II



Bare, Max G Tri 4-Bar	
with 3" Exhaust.....	\$5,635.00
9" Hsg w/Brackets	1000.00
Tri 4-Bar for Above	410.00
IFS Upper/Lower Control Arms.....	895.00
Wilwood Pro Spindles	325.00
DSE Power Rack.....	565.00
Tie Rod Ends	50.00
TOTAL.....	8,880.00
Package Discount.....	300.00
Package Price.....	\$8,580.00

Key Features Of Morrison's "MuscleCar" Max G Chassis

- CAD-Engineered to fit the exact year, make and model car. No compromises!
- Your choice of ride height and stance
- Superbly engineered suspension package provides vastly improved handling
- Body "drops" on chassis after floorboard has been removed
- Mandrel-formed 2"x4" frame fixture-welded by experienced professionals
- Choice of Corvette or AME's own IFS
- Choice of Tri 4-bar, 4-bar, AirRide or 4-link rear suspensions or IRS
- Strange Engineering adjustable coil-over shocks on all four corners
- Through-frame passages for 3" exhaust and driveshaft provides lower CG with ample ground clearance
- Uses 20:1 power rack steering





Sport C6/3-Link Max G Combo Is Perfect For Track Day Builds!

Thanks in part to our new dropped steering arm C6 spindles, we've been able to engineer a chassis that brings the C6 front suspension to many platforms. And when combined with the a 3-Link rear suspension utilizing a Watts linkage, the corner-carving capability of cars equipped with a Max G chassis is beyond comprehension. Build your next ride on this platform and it will be difficult to wipe the smile off your face!



Shown with optional Sport C6 Suspension

J-Rod & Custom
1967 Nova



George Poteet's 1969 Torino
built by Troy Trepanier



Bare, Max G Muscle Car for 3-Link	
with 3" Exhaust.....	\$6,765.00
9" Hsg w/Brackets for 3-Link.....	1,160.00
3-Link for Above, Johnny Joint.....	710.00
Strange Coil-Ovr Shcks w/Sprngs, Rr.....	524.00
Watts Link Kit for Above.....	440.00
Lower Mount Stud Kit.....	45.00
Sport C6 w/Drop'd Strg Arms.....	2,745.00
Sway Bar & Mount Kit, Rear.....	280.00
Sway Bar & Mount Kit, Front.....	350.00
Tie Rod Ends, 5".....	50.00
DSE Power Rack.....	565.00
Strange Coil-Ovr Shcks w/Sprngs, Frt.....	524.00
TOTAL.....	14,158.00
Package Discount.....	300.00
Package Price.....	\$13,858.00

Photo by: NatStock Photography



Morrison has re-engineered the C6 front spindle with a lower steering arm mount. This allows the rack to be mounted lower in the chassis, providing extra engine clearance and a lower center of gravity!



MORRISON



23

800-929-7188 • fax: 253-922-8847 • www.artmorrison.com

“Builders” and “Bolt-On” Chassis

At Art Morrison Enterprises, we offer two basic types of complete frames; a “Bolt-On” chassis like our “GT Sport” models, or a “Builder’s Platform” that describes our “MaxG” and others. The primary difference is that the “Bolt-On” chassis requires little or no welding. It’s the type of project that a do-it-yourselfer can tackle with confidence. Everything that’s needed to mount the core support, body, bumpers, etc. is welded in place.

The “Builder’s Platform” includes all our bumper-to-bumper 2”x3”, 2”x4”, 4”x4”

and 2”x6” frames (MaxG, PROfile, etc.). These *do not* have the bumper mounts, body mounts, core support, engine and transmission mounts welded in place. This gives builders the maximum amount of leeway when it comes to positioning the engine relative to the firewall, etc. Given the amount of flexibility with the installation, it should be stressed that advanced

fabrication skills and solid knowledge are recommended before tackling a project of this magnitude. To aid in the construction of a “Builder’s Platform” chassis, AME offers a wide assortment of mounts and brackets that can be employed.

It’s no wonder that a growing legion of professionals have found Morrison’s “Builder’s Platform” frames the way to go!



“BUILDER’S PLATFORM”

“BOLT-ON CHASSIS”

4-Bar vs. 4-Link: A Tech Overview...

One of the FAQs (frequently asked questions) fielded by AME’s tech staff relates to preference between 4-bar and 4-link rear suspensions.

In a nutshell, a 4-link setup is best suited to Drag Race or Pro Street type vehicles where high horsepower engines and large tires are being used. The 4-link

can be adjusted easily to compensate for track conditions and control the amount of “hit” the tire takes on the launch. And due to the high kick-up of the frame rails, modifications to the trunk and rear floor are required—often times the rear seat must be removed.

The 4-bar has longer, parallel bars and

a lower frame kick-up. It is ideally suited to street and air spring suspension setups, provides more latitude in setting ride height and its polyurethane-bushed rod ends make for a smoother, quieter ride. In most installations the rear seat can be retained, with little or no modifications the seat itself. It’s neat for the street!



4-BAR



4-LINK

Which Rod End is best for my application?



**Johnny Joint
Rod End**



**Poly
Rod End**



**Spherical
Rod End**



**Solid
Rod End**

Johnny Joint - Developed by Currie Enterprises and originally made for the 4WD market, the Johnny Joint is a fairly new offering in our suspension lineup. The Johnny Joint is made up of a forged steel body and a heat-treated pivot that is surrounded by polyurethane. Rebuildable and externally greasable through a zerk fitting, the Johnny Joint is very maintenance friendly. This is a great combination of a high articulation spherical rod end with the harmonic dampening of a poly rod end. Perfect for high performance street and track day vehicles where comfort, strength and performance are a priority. These rod ends fit a lot of different suspension applications. Because of their size they might need some extra clearance for retro-fit applications.

Spherical - Spherical rod ends are specifically used to provide maximum strength for high load applications. Manufactured out of a lot of different materials, the 4130 spherical end is one of the strongest, with the 3/4" rod end yielding at 40,572 lbs. Providing a high degree of articulation, they are perfect for a wide variety of suspension applications. Because of their all-metal construction they will transmit road harmonics through the chassis and an audible "clunk" can be heard in the end when they begin to wear out. While they are expensive, the spherical rod end is perfect for racing and all out performance applications where the focus of the build isn't concerned about maximizing comfort.

Poly - "Poly" rod ends have become the industry standard rod end over the years. Our version of this highly popular end is investment cast from 17-4 Stainless Steel. Inside, is a steel sleeve and two polyurethane bushings. While not a spherical rod end the durometer of the polyurethane allows the bushings to flex and gives the rod ends some rotational movement. It isn't a lot of movement, but it does allow suspension to articulate through its normal range of movement. When assembled with grease, the poly material can have a long life under normal road conditions. Lubrication also prevents any "squeaking" associated with poly rod ends. They also do a great job of insulating the suspension and vehicle from unwanted road noise. Easily rebuildable, these rod ends can have new bushings installed in a very short time. Because this stainless steel rod end can be disassembled so easily it can be polished for "show car" applications. Intended for street and high performance road applications.

Solid - machined out of heat treated 4140 steel, the solid rod end is one of the strongest available. Yielding at 58,000 lbs of force, it is designed for punishment. The solid rod end is also basic and inexpensive, but because it is a "solid" end, there isn't any rotational movement available. This also transfers road harmonics and other noise from the suspension directly to the chassis. Because of its limitations, the ladder bar suspension is its only fit. Designed for drag race applications only.



Special Chassis For Convertibles And Long-Wheelbase Cars



1947 Cadillac built by Kindig-It Design



As Shown **\$10,508**

Bare Fixture-Welded 2"x4"x4"	
Main Profile Frame with 3" Exh.....	\$5,400.00
9" Housing with Brackets	1000.00
Tri 4-Bar for Above	410.00
Internal Frame with 3" Exhaust.....	600.00
IFS Upper/Lower Control Arms.....	895.00
Wilwood Pro Spindles	325.00
DSE Power Rack & Pinion.....	565.00
Strange Front and Rear Coil-Over.....	1048.00
C/O Lower Mount	45.00
Tie Rod Ends	50.00
Front Sway Bar	190.00
Rear Sway Bar.....	280.00
TOTAL.....	10,808.00
Package Discount.....	300.00
Package Price.....	\$10,508.00

4x4
Main Rails

1948 Buick
built by ICON



There are several key reasons why convertibles and long-wheelbase cars should use this chassis. In the case of convertibles, they essentially have no structure above the rocker panel and need extra rigidity to support the center of the body. Long-wheelbase cars have a similar issue with chassis flex, due to the torsional action of the stretched frame. To provide owners of convertibles, long wheelbase sedans and hardtops with the best possible ride and handling, the engineering team at

Art Morrison Enterprises has developed a specially reinforced chassis that features 4"x4" main rails. This has been accomplished by merging the 2"x4" front subframe with a 4"x4"x .180" wall square tube main rail, resulting in remarkable rigidity in the area where an OEM frame is likely to flex.

Of course, "stance" is all-important with any custom vehicle. And Morrison can engineer the chassis to provide the exact ride height you desire. What's more,

because of the exhaust passages in the frame, it's possible to have a very low stance, while maintaining ample ground clearance. Lowering the vehicle's center of gravity also improves handling.

With the frame rails configured to the exact year/make/model vehicle, it's a fairly straightforward task installing the chassis. The 4"x4" main rail chassis can be designed for use in both "unibody" and full-frame vehicles. Call for details on various suspension options.

Key Features Of Morrison's 4x4 Main Rail Chassis

- **CAD-Engineered to fit the exact year, make and model car. No compromises!**
- **Your choice of ride height and stance**
- **Superbly engineered suspension package provides vastly improved handling**
- **Mandrel-formed 2"x4" front profile with a 4"x4"x3/16" main rail**
- **Frame is fixture-welded to assure proper alignment of all suspension components**
- **Choice of AME's own IFS, Corvette or Air Spring-Plus front suspension**
- **Triangulated 4-bar, 4-bar, Air Spring-Plus or IRS rear suspension options**
- **Through-frame passages for 2.5" or 3" exhaust provide lower CG with ample ground clearance**
- **Uses 20:1 Power Rack & Pinion steering**
- **Strange coil-overs on all corners**

MORRISON

26



800-929-7188 • fax: 253-922-8847 • www.artmorrison.com



New Heavy-Duty Chassis Engineered For Classic Pickup Trucks



Photo Courtesy Mike Chase Photo Design

1937 Dodge truck built by Cotati Speed Shop



Hefty 2"x6" main rails provide the bridge strength necessary for chassis stiffness.

2x6
Main Rails

Priced from \$9,178
*Shown with suspension upgrades

Bare Fixture-Welded 2"x4"x6" Truck	
Frame with Exhaust	\$4,865.00
9" Housing with Brackets	960.00
Strange Rear Coil-Overs	524.00
4-Bar Kit for Above	370.00
Carrier Mount Panhard Bar	150.00
C/O Lower Stud Mount	45.00
Sport IFS Control Arms	1100.00
Wilwood Pro Spindles	325.00
DSE Power Rack & Pinion	565.00
Tie Rod Ends	50.00
Strange Front Coil-Overs	524.00
TOTAL	9478.00
Package Discount	300.00
Package Price	\$9,178.00

More and more builders are wanting to combine the classic styling of '40s, '50s and '60s pickup trucks with modern driveline and suspension technology. All this, plus an attractive, road-hugging stance.

Art Morrison Enterprises now offers a unique chassis that has an ultra-rigid "backbone" that provides builders with the perfect foundation for any classic truck project.

Morrison engineers started with a big 2"x6" main rail, complimenting it with

mandrel-formed 2"x4" front and rear subframes—all fixture welded to assure the perfect alignment of all suspension components.

The chassis also features thru-frame exhaust passages, which allow the truck to have a lower overall stance while still maintaining ample ground clearance. In addition to being designed for the exact year/make/model truck, Morrison can build in the exact ride height desired to obtain a contemporary stance.

There are a variety of suspension options, including Air Spring-Plus or I.F.S. up front and a 4-bar or triangulated 4-bar in the rear (plus Air Spring).

All in all, there is no better frame on the market for Classic Truck applications than Morrison's 2"x6" main rail chassis. It's simply better built for the job at hand.

Contact Morrison's knowledgeable sales staff to discuss which suspension options are best suited to your project.

Key Features Of Morrison's 2x6 Main Rail Pickup Chassis

- CAD-Engineered to fit the exact year, make and model truck. No compromises!
- Your choice of ride height and stance
- Superbly engineered suspension package provides vastly improved handling
- Beefy 2"x6" main rail with precision mandrel-formed 2"x4" subframes 180 wall tubing
- Frame is fixture-welded to assure proper alignment of all suspension components
- Choice of AME's own IFS, Sport IFS or Air Spring-Plus front suspension
- Triangulated 4-bar, 4-bar or Air Spring-Plus rear suspension options
- Through-frame passages for 2.5" or 3" exhaust provide lower CG with ample ground clearance
- Uses 20:1 Power Rack steering
- Several coil-over spring options



2x4 Straight Rails

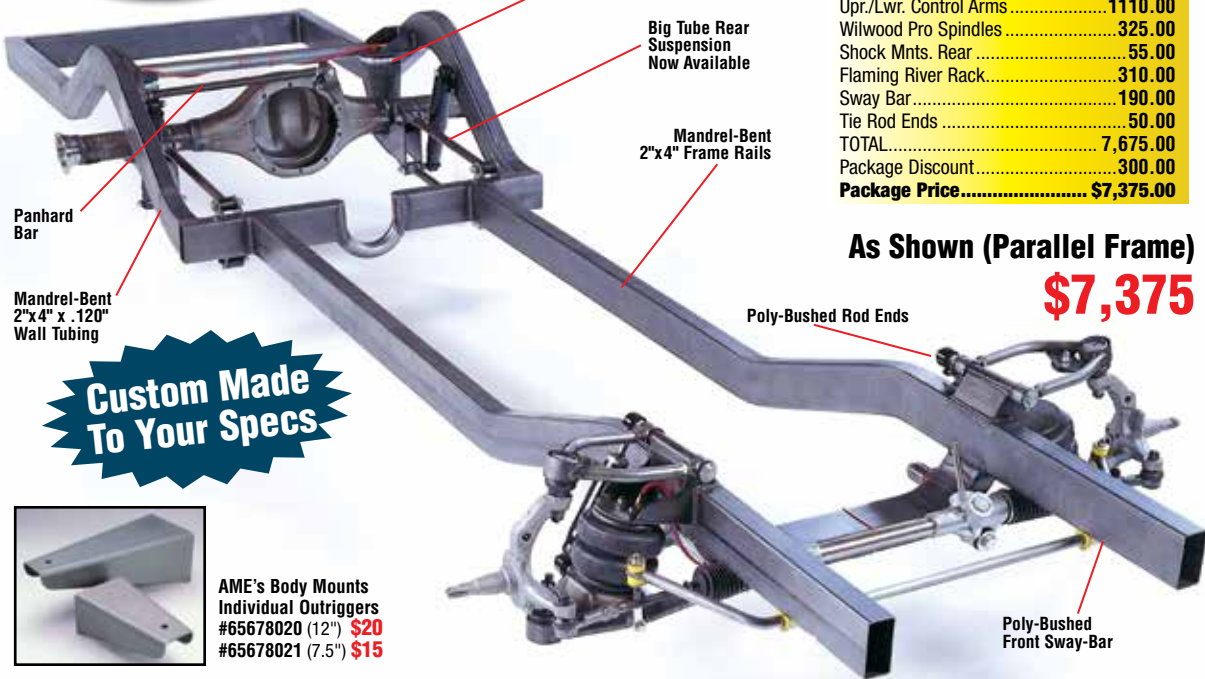

2"x4" Welded Air Frame w/Mts..	\$3,405.00
9" Hsg. w/Brackets.....	960.00
Air Bags Frt. and Rear.....	540.00
Shocks Frt. and Rear.....	200.00
4-Bar Kit for Above.....	370.00
Hi Mis Carrier Mt. Pnhrd Kit for Above.....	160.00
Upr./Lwr. Control Arms.....	1110.00
Wilwood Pro Spindles.....	325.00
Shock Mnts. Rear.....	55.00
Flaming River Rack.....	310.00
Sway Bar.....	190.00
Tie Rod Ends.....	50.00
TOTAL.....	7,675.00
Package Discount.....	300.00
Package Price.....	\$7,375.00

As Shown (Parallel Frame)
\$7,375



AME's Body Mounts
Individual Outriggers
#65678020 (12") \$20
#65678021 (7.5") \$15

Beefy 2"x4" rectangular tubing is 33% stronger than ordinary 2"x3" rails and requires less cross-bracing for torsional stability

Offered in kit form or factory welded by experienced professionals

Beautiful show quality mandrel bends

Front kick-up to provide the desired ride height

Complete rear housing packages are available

Available with 4-link, ladder bar or 4-bar rear suspensions

Available with Strut or I.F.S.

As Shown
\$7,708

2"x4" Welded Frame w/suspension mounts and 3" exhaust passages.....	\$3,500.00
9" Housing with Brackets.....	960.00
L-Bracket Kit.....	50.00
Strange Front Coil-Overs.....	524.00
Strange Rear Coil-Overs.....	524.00
4-Link Kit for Above 8 Poly R/E's.....	520.00
Weld-On Panhard Bar for Above.....	95.00
IFS Upr./Lwr Control Arms.....	895.00
Wilwood Pro Spindles.....	325.00
DSE Power Rack & Pinion.....	565.00
Tie Rod Ends.....	50.00
TOTAL.....	8,008.00
Package Discount.....	300.00
Package Price.....	\$7,708.00

Choose What's Best For Your Particular Application!

- Numerous applications
- Custom made for your project
- Many suspensions available

MORRISON



2x4 Profile Rails

AVAILABLE WITH
**NEW
Multi-Link
IRS**

Front kick-up
to provide
the desired
ride height

Complete rear
housing packages
are available

Beautiful show quality
mandrel bends

Offered in kit form
or factory welded by
experienced professionals

Available with
4-link, ladder
bar or 4-bar rear
suspensions

As Shown
\$8,453

Beefy 2"x4" rectangular
tubing is 33% stronger
than ordinary 2"x3" rails
and requires less cross-
bracing for torsional
stability

Mandrel Bent Perimeter Fit

We Make It Easy For Builders!

Our 2x4 Profile frames are CAD engineered to the exact make/model vehicle. The builder has only to install the body mounts to complete the chassis. The stance and ride height are made to the builder's specs.

**Custom Made
To Your Specs**

Bare Profile Welded Frame w/Exh...	\$4,135.00
9" Housing with Brackets	960.00
Strange Rear Coil-Overs	524.00
4-Bar Kit for Above	370.00
Carrier Mat, Panhard Bar	150.00
C/O Lower Strut Mount	45.00
IFS Upper/Lower Control Arms	895.00
Wilwood Pro Spindles	325.00
DSE Power Rack	565.00
Tie Rod Ends	50.00
Strange Front Coil-Overs	524.00
2"x4" PROFILE BASIC PKG. TOTAL	8,534.00
Package Discount	300.00
Basic Package Price	\$8,243.00
Shown with Optional:	
Narrow Track Power Rack add-on	210.00
As Shown Package Price	\$8,453.00

AIR SPRING PLUS

Photo Courtesy Nox Box Photography



63 Rods 37 Packard

9" Housing
with Suspension
Mounts

**Custom Made
To Your Specs**

Heavy-Duty
1.125" x .156"
Wall DOM Tubular
Lower Control Arms

4-bar rear
suspension
with Panhard Bar



Center Frame option with
3" exhaust passages

DSE Power Rack & Pinion
steering 20:1 ratio

As Shown
(Profile Frame)
\$9,145

2"x4" Welded Air PROfile Frame w/Center Frame option & Suspension Mounts	\$5,110.00
9" Hsg. w/Brackets	960.00
Air Bags Frt. and Rear	540.00
Shocks Frt. and Rear	200.00
4-Bar Kit for Above	370.00
Hi Mis Carrier Mnt. Pnhrd Kit for Above	160.00
Upr/Lwr Control Arms	1110.00
Wilwood Pro Spindles	325.00
Shock Mounts Rear	55.00
DSE Power Rack	565.00
Tie Rod Ends	50.00
TOTAL	9,445.00
Package Discount	300.00
Package Price	\$9,145.00



MORRISON



29

800-929-7188 • fax: 253-922-8847 • www.artmorrison.com

Welded/Unwelded Frames & Kits



For drag racing and Pro Street applications we offer complete Bumper-To-Bumper frames and subframes made of 2"x3"x.120" wall rectangular tubing. This lighter frame material is ideal for reducing vehicle weight—essential for performance. However, it is highly recommended that a roll cage (see pages 52-54) be integrated into the chassis. We've seen builders stuff a blown big block into a light weight Pro Streeter without the benefit of a cage for chassis stiffening and driver protection.

2"x3" Drag Race/Pro Street Welded Frame

As Shown
\$2,110

2"x3" Rear Subframe Kit



Ladder Bar and 4-Link As Shown
\$600

Available with I.F.S. or Strut Front Suspensions

Lightweight Front Crossmember

Custom Made To Your Specs!

Unwelded 2x4" Rear Subframe Kits



Ladder Bar and 4-Link As Shown **\$750**



4-Bar As Shown **\$750**

MORRISON

30



800-929-7188 • fax: 253-922-8847 • www.artmorrison.com

Chassis Accessories

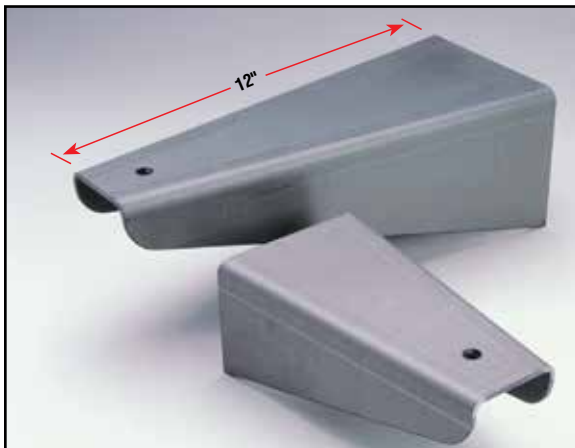

Formed Body Mounts

These formed steel mounts are available in 12" & 7.5" overall lengths. Easily trimmed to desired size.

- 65678020 12" Body Mount (Each) \$20.00
 65678021 7.5" Body Mount (Each) 15.00

90° Bends for Special Uses

Builders have asked us to custom make small sections of 90° mandrel bent tubing, and they've become so popular we've decided to make them a standard catalog item. The "hard way" bends are on the 2" tall section, while the "easy way" is on the wider 4" section.



- 32347200 (A) 36" Hard-way 2"x4" \$65.00
 32347210 (B) 30" Easy-way 2"x4" 60.00
 32347215 36" Hard-way 2"x3" 60.00
 32347214 36" Easy-way 2"x3" 60.00



Universal Body Mount Kit w/Bushings

- 65678000 Outrigger Body Mount Kit (6 Sets) \$95.00
 65678001 Outrigger Body Bushing 2.50
 33334000 Outrigger Body Mount (Each) 15.00

2"x4" Crossmember With Loop



More crossmembers on page 61

Here's another AME chassis component that builders have asked for individually. It's an elegant solution for providing the safety of a driveshaft loop with a chassis-stiffening crossmember.

- 33330131 2"x4" Crossmember with Center Donut \$245.00
 33330132 2"x4" Crossmember with Offset Donut 245.00
 33330133 2"x4" Crossmember with Donut Unwelded 160.00
 33330140 2"x4" Crossmember with Center Donut w/Exhaust 2-1/2" 340.00
 33330142 2"x4" Crossmember with Center Donut w/Exhaust 3" 405.00

Center Frame Kit Unwelded

One of the more significant features of the Morrison GT Sport chassis has been the center frame treatment and routing the exhaust through passages in the crossmember. This allows for a lower stance, without having to worry about mufflers and pipes hanging below the bottom of the frame. Because of the popular acceptance of this feature and request from builders, we have developed a special kit that allows a constructor to easily adapt this design to other chassis. Components are mandrel-formed out of 2"x4" rectangular tubing (.120" wall) and kits are offered with or without the exhaust tubes.

- 32347100 Center Frame Kit \$340.00
 32347101 Center Frame Kit without Exhaust Tubes 295.00
 32347102 Center Frame Kit with 3" Exhaust 390.00

Popular Rear Clips & Suspensions

Art Morrison Enterprises offers the industry's widest selection of front and rear suspensions, including air, coil-over and strut front setups and air or coil-overs for the rear. This ensures that you can obtain the best possible combination of performance and comfort for your particular vehicle. You should know that all Morrison suspension systems have been carefully computer-engineered to assure optimum operational efficiency—with the front suspensions designed for "0" bump steer. These suspensions

are available on bumper-to-bumper chassis, or subframe assemblies. Further options on rear suspensions include a choice between Morrison's polyurethane-bushed stainless steel rod ends for quieter, softer street use or spherical bearings for more rigid and precise competition applications. With no less than nine different front and rear suspension options, it's clear that nobody gives you more choices than Art Morrison! Call our tech staff for input on what's best for your application.

TRIANGULATED 4-BAR

FOR
STREET
RODS &
"G"
MACHINES

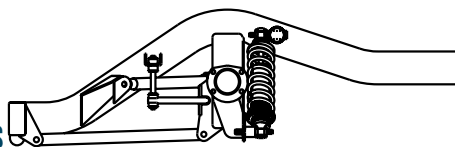

LADDER BAR

FOR
RACE
CARS
& PRO
STREET

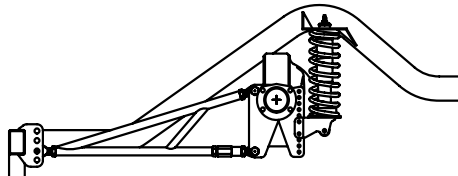

AIR SPRING

FOR
STREET
RODS &
PICKUP
TRUCKS

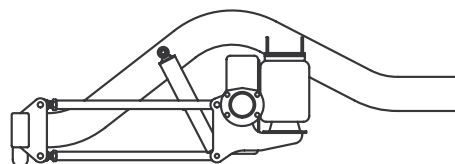

FOUR LINK

FOR
RACE
CARS
& PRO
STREET

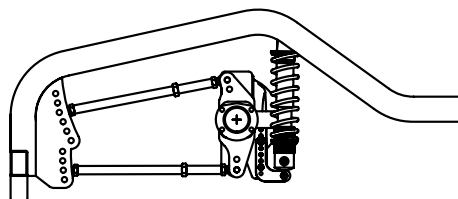

FOUR BAR

FOR
STREET
RODS &
PICKUP
TRUCKS

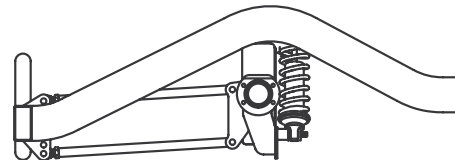

THREE LINK

FOR
STREET
RODS &
"G"
MACHINES

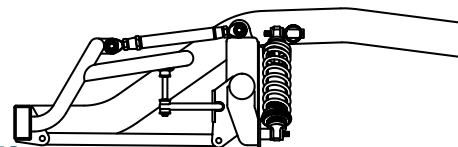

REAR CLIP AVAILABILITY CHART

Rear Clip Rail Size and Suspension Type

Price

Mandrel-bent .120" wall rectangular tubing

Fully factory welded 2"x3" clip, set up for a 4-link suspension	\$1,045.00
Fully factory welded 2"x3" clip, set up for a ladder bar suspension	1,045.00
Fully factory welded 2"x4" clip, set up for a 4-link suspension	1,470.00
Fully factory welded 2"x4" clip, set up for a ladder bar suspension	1,470.00
Fully factory welded 2"x4" clip, set up for a 4-bar suspension	1,470.00
Fully factory welded 2"x4" clip, set up for a triangulated 4-bar suspension	1,685.00
Fully factory welded 2"x4" clip, set up for an air 4-bar suspension	1,485.00
Fully factory welded 2"x4" clip, set up for a 3-link suspension	2,125.00

MORRISON

32



800-929-7188 • fax: 253-922-8847 • www.artmorrison.com

3-Link Rear Clip

Package As Shown
\$5,464

*The Ultimate In
Corner Carving
Technology*



NOTE: Subframe can be ordered with optional 3" exhaust ports

Bare, 3-Link Clip, Wide Hoop	\$2,275.00
3-Link Housing	1,315.00
Watts Link Kit for Above.....	440.00
3-Link Tubes, Johnny Joint.....	710.00
Sway Bar & Mount Kit, Rear	280.00
Lower Shock Mount Stud Kit	45.00
Strange Coil-Overs with Springs	524.00
TOTAL.....	5,589.00
Package Discount.....	125.00
Package Price	\$5,464.00



Engineered To Fit Your Application

The engineering staff at Art Morrison Enterprises has developed this new 3-Link Rear Suspension Clip that is designed to improve the handling and performance in a wide variety of street machines and muscle cars. Of course, each subframe is CAD-designed for the particular year/make/model vehicle—including the desired ride height—to provide optimum ease of installation.

From a technical standpoint, the 3-Link configuration—in concert with a Watts-type linkage—provides complete multi-axis control. Add the Strange Engineering adjustable coil-over shocks and a sway bar to the 3-Link package, accounting for optimum compression/rebound and roll control.

The rugged 2"x4" rectangular steel tube frame rails and

crossmembers are precisely mandrel-formed, and the assembly fixture-welded to assure correct alignment of all suspension components. Optional 3" exhaust ports can be installed in the front crossmember, enabling the vehicle to have a lower stance without compromising ground clearance.

A specially-modified 9" Ford rear housing is also part of the package. It's fitted with mounts for the Watts linkage, coil-over shocks and link bars. The bars feature Morrison's poly-bushed stainless steel rod ends, which provide firm control and quiet operation. For all-out competition, a spherical rod end package is available. Of course, axles, brakes and complete 3rd members are available from AME to complete the installation.

**This kit comes in welded form only*



MORRISON
PERFORMANCE
AM
QUALITY
33

800-929-7188 • fax: 253-922-8847 • www.artmorrison.com

Triangulated 4-Bar Suspensions

Tri 4-Bar Rear Clip

For the growing numbers of street rodders who appreciate good handling, Art Morrison has developed the triangulated 4-bar rear suspension, now used in the Max G and Tri-5 chassis. The crossmember has passages for the exhaust and for the driveshaft for a low center of gravity and improved handling. The suspension setup controls both housing "twist" and lateral movement. The "big tube" 1-3/8" diameter bars feature Morrison poly-bushed stainless steel rod ends. The rear sway-bar, coil-over shocks, and 9" housing complete the package.

2"x4" Welded Rear Clip w/Brkts.....	\$1,780.00
9" Housing w/Brackets.....	1,000.00
Strange Coil-Overs.....	524.00
C/O Lower Stud Mount.....	45.00
4-Bar Kit for Above.....	415.00
Sway-Bar Kit.....	280.00
TOTAL.....	4,039.00
Package Discount.....	125.00
Package Price.....	\$3,914.00

Tri 4-Bar Kit

There's no doubt that this is the most versatile setup for both street rods and GT-type cars as it provides excellent rear end control in both acceleration and handling situations due to stabilizing both housing rotation and side loading. It's been proven highly effective in tests conducted by leading automotive enthusiast publications. The kit contains four bars with AME polyurethane-bushed stainless steel rod ends, plus all required mounting brackets and hardware. Kit also available with a sway-bar to provide extra control over body roll.

Tri 4-Bar Kit Without Sway-Bar.....	\$530.00
Tri 4-Bar Kit With Adjustable Sway-Bar.....	810.00

Tri 4-Bar Suspension

Now it's easy to install a modern Triangulated 4-Bar rear suspension in most any chassis with this convenient package. It contains an AME Triangulated 4-Bar kit, sway bar, Aldan coil-over springs, shock mounts and hardware.

Tri 4-Bar Kit with Sway.....	\$810.00
Strange Coil-Overs.....	524.00
C/O Lower Mount Kit.....	145.00
Crossmember and Upper Mounts.....	50.00
TOTAL.....	1,529.00
Package Discount.....	50.00
Package Price.....	\$1,479.00



Clip Package

As Shown
\$3,914



As Shown
\$530

Tri 4-Bar Kit



Tri 4-Bar Kit w/Sway-Bar

As Shown
\$810



Tri 4-Bar Suspension Package w/Sway

As Shown
\$1,479

MORRISON



4-Bar Clips

As Shown
\$3,394



4-Bar Clip Package

2"x4" Welded Rear Clip w/Brkts.....	\$1,470.00
9" Hsg. w/Brackets.....	960.00
Strange Coil-Overs.....	524.00
C/O Lower Stud Mnt.....	45.00
4-Bar Kit for Above.....	370.00
Carrier Mnt. Panhard Kit for Above.....	150.00
TOTAL.....	3,519.00
Package Discount.....	125.00
Package Price.....	\$3,394.00

4-Bar Clip Package

For many applications, the 4-bar suspension is preferred. Operating on the principle of a "constant motion parallelogram," the design of the 4-bar is such that the rear end housing is always perpendicular to the ground—pinion angle never changes. This, combined with the lateral stability of the Panhard Bar, does an excellent job of locating the rear end and keeping it in proper alignment.

You will note that the rear frame "kick up" of the 4-bar setup is far less severe than what is required for a 4-link or ladder bar suspension. This is beneficial for many street applications, where interior and trunk space is at a premium. Likewise, use of a 4-bar setup in a pickup truck will minimize the area wheel tubs encroach into the bed. It's the hot setup for a low profile!

Morrison's complete 4-bar clip assemblies include a 2"x4" rectangular tube rear subframe that is CAD-engineered for the applications. Each is designed for the year/make/model vehicle to assure a correct fit and make for the optimum ease of installation. Moreover, each subframe is precision fixture-welded by expert

technicians to assure the proper alignment of chassis and suspension components.

The husky 2"x4"x.120" wall rectangular tubing is mandrel-bent to assure a superb finish and "show quality" bends. The assembly comes with a driveshaft hoop and all suspension brackets. The 4-bar setup features Morrison's highly regarded

polyurethane-bushed stainless steel rod ends and coil springs rate-matched to the application and coil-over shock absorbers.

Complete 9" rear end assemblies are also available. Don't forget to ask your friendly Morrison salesman for extra savings when ordering parts.

4-Bar Kit.....	\$435.00
Strange Coil-Overs.....	524.00
C/O Lower Mount Kit.....	145.00
Crossmbr. & Upper Mkts.....	50.00
Carrier Mnt. Panhard Kit.....	150.00
TOTAL.....	1,304.00
Package Discount.....	50.00
Package Price.....	\$1,254.00

4-Bar Suspension

As Shown
\$1,254



Air Spring+Plus™ Rear Clip

For those applications where the builder wishes to adapt a Morrison Air Spring+Plus™ suspension to an existing chassis, special rear subframe assemblies are available. Like all other Morrison frame components, the subframes are individually CAD-engineered for the exact year/make/model vehicle and the rails are mandrel-bent to form "show quality" bends.

The subframes are made of 2"x4"x.120" wall rectangular tubing, and fixture-welded by Morrison's staff of experienced craftsmen to assure proper alignment of critical suspension components.

Air Spring+Plus™ suspension packages are available individually for rear subframes. It pays to buy necessary related items at the same time.

The rear subframe package shown at above right has a fixture-weld clip, 4-bar rear suspension, Air Springs, shocks, Panhard Bar and narrowed 9" rear end.



As Shown **\$3,310**

**AIR
SPRING
PLUS**

**Big Tubes
Now Standard**

2"x4" Welded Air 4-Bar Rear Clip w/Exh.	\$1,570.00	Hi-Mis Carrier Mnt. Pnhrd Kit for Above	. 160.00
9" Air Hsg. w/Brackets.....	960.00	Air Bags Rear	220.00
Shocks Rear	100.00	TOTAL.....	3,435.00
4-Bar Kit for Above	370.00	Package Discount.....	125.00
Shock Mnts. Rear	55.00	Package Price.....	\$3,310.00

Air Spring+Plus™ 4-Bar Suspension

Now you can enjoy the benefits of an air spring suspension and 4-bar housing control with these handy packages from Art Morrison Enterprises. You'll weld the innovative rear brackets (which also serve to mount the bottom of the air spring and locate the suspension bars) to the rear end housing, attach the 4-bar front brackets to a crossmember, and affix the top air bag mount to your frame or supplied crossmember ("Big Bag" kit). The "Standard" kit is ideally suited to most compact and intermediate-sized vehicles, while the "Big Bag" kit is designed for use on heavier cars and trucks. The primary differences between the two kits are the use of hefty 2,000 lbs. rated air bags and heavy-duty brackets. These combine to provide the extra capacity required for long-term reliability. The kits contain premium quality Firestone air bags, 4-bars bars equipped with AME's own polyurethane-bushed stainless steel rod ends, mounting brackets and all required hardware. Replace the coil or leaf spring setup on your car or truck with an Art Morrison Air Spring+Plus suspension for a better ride and the ability to easily adjust ride height at the flick of a switch.

We also manufacture Air Spring-Plus front subframes so you can easily convert the vehicle over to an all-air suspension for a great ride with complete adjustability. See page 41.

"Standard" Kit (As Shown)

AIR3105

\$885



"Big Bag" Kit (As Shown)

AIR3180

\$1,660



Heavy-Duty Brackets and 2,000 lb. Air Springs

MORRISON

36



800-929-7188 • fax: 253-922-8847 • www.artmorrison.com

4-Link Clips

Complete Competition Package

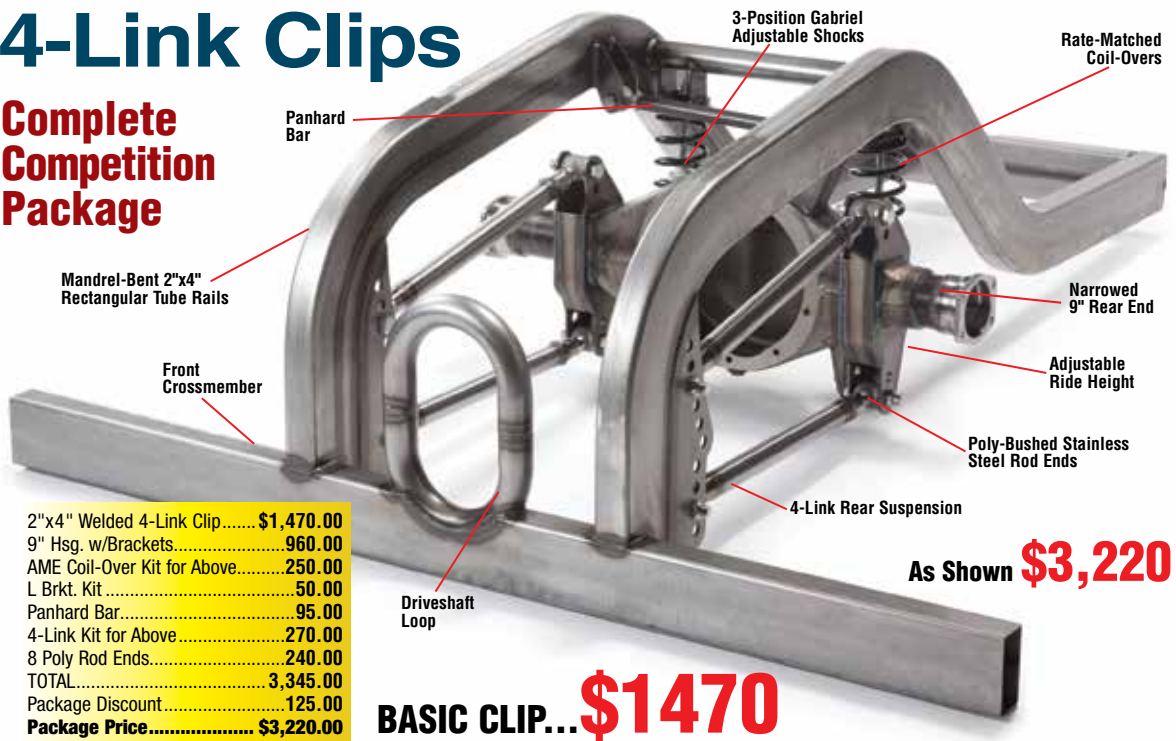

2"x4" Welded 4-Link Clip.....	\$1,470.00
9" Hsg. w/Brackets.....	960.00
AME Coil-Over Kit for Above.....	250.00
L Brkt. Kit.....	50.00
Panhard Bar.....	95.00
4-Link Kit for Above.....	270.00
8 Poly Rod Ends.....	240.00
TOTAL.....	3,345.00
Package Discount.....	125.00
Package Price.....	\$3,220.00

As Shown **\$3,220**

BASIC CLIP... \$1470

Art Morrison's 4-link rear suspensions are perfect for competition or street applications where maximum adjustability is desired. There are six upper bar front mounts plus four lower bar attachment holes, along with two top and bottom housing mounts and adjustable bars to provide you with any "instant center" point desired.

The link tubes are 1-3/8" chrome-moly with threaded tube adapters for maximum strength. Mounting plates are made of 3/16" steel and of a double shear, 360° design.

We also offer a "Big Tube" unwelded kit, which also features large diameter .095" wall tubing.

You have a choice between three rod end packages. For street applications our special polyurethane-bushed 17-4 stainless steel rod ends are utilized. They are exceptionally rugged, and provide the necessary quietness for street operation. For racing, our popular "4/4" kit consists of four 4130 chrome moly and four commercial grade rod ends, while for maximum reliability we offer all 4130 rod ends.

Most of our 4-links are sold in complete rear suspension packages. They include the 4-link with frame and housing brackets, coil-over rear shocks with springs rate-matched to your application and a choice of a Panhard Bar (for street use) or diagonal link (race).

Package Prices

4-Link with Poly-bushed Stainless Rod Ends and Coil-Over Shocks, Panhard Bar.....	\$1,040.00
4-Link with Four Commercial & Four 4130 Rod Ends, Coil-Over Shocks & Diag. Link.....	1,055.00
4-Link with all 4130 Rod Ends, Rate-Matched Coil-Over Shocks and Diagonal Link.....	1,135.00

You can also purchase the basic 4-link kit by itself plus three variations of rod end packages (poly-bushed, four commercial and four 4130 or all four 4130 rod ends).

4-Link Rear Suspensions

As Shown **\$1055**



4/L Kit w/4 4130 & 4 Comm. R/E's.....	\$680
AME Coil-Over Shocks.....	260
Coil-Over Mounting Kit.....	80
Bolt-On Diagonal Link Kit.....	85
TOTAL.....	1105
Package Discount.....	50
Package Price.....	\$1055

All 4-Links use "Big Tube" Design

#14145090 (Less Rod Ends) "Big Tube" 4-Link Kit

As Shown **\$370**



Chrome Moly Tubes 1-3/8" Upper Tubes 18" Long 1-3/8" Lower Tubes 18" Long



A #14141200 - \$240.00



B #14141100 - \$280.00



C #14141000 - \$360.00

Morrison makes it easy to install narrowed rear end and wide tires with this factory-welded Ladder Bar rear suspension subframe assembly. The "clip" includes mandrel-bent rear frame rails, cross-members and suspension mounts. Each clip is assembled on a special fixture to assure proper alignment and welded by certified professionals. Most importantly, each "clip" is custom designed and built for the intended application using contemporary CAD technology. This assures a perfect fit and eliminates the extra fabrication required to install "universal" type assemblies as sold by our competition. Over the years Art Morrison Enterprises has designed and built rear suspension clips for a wide variety of vehicles. Dozens and dozens of popular applications (and some quite unusual) are maintained in Morrison's data server, and can be promptly accessed to initiate building a clip for your year/make/model car or truck.

What's more, only Morrison gives you the choice of using 2"x3" or 2"x4" rectangular tubing. You also have a choice of a dropped crossmember or the highly effective "donut" style combination cross-member and driveshaft loop in 2"x3" rails.

For a racing or "Pro Street" application you'll probably want to go with the 2"x3" clip. It's a third lighter than the beefier 2"x4" models,

Competition & Street Ladder Bar Packages

Our Ladder Bar Packages include our Double Adjustable Ladder Bar Kit, cross-member tube with brackets, axle housing mounts, spring mounts, our Morrison spring kit with adjustable shocks and rate matched springs.

The Competition Package includes 4140 solid rod ends and diagonal link kit. Prices start at **\$695.00**.

Our Street Package uses poly-bushed stainless rod ends for a quieter ride and a Panhard Bar kit. Prices start at **\$730.00**.



10102230
10102232
10102330

(A) Pro/Street Kit
(w/2 Ply Bshd S/S Rod Ends) **\$410.00**
(B) Competition Kit

10102332 (w/2 Chrome Moly Rod Ends)..... **430.00**
10102030 (C) Pro/Comp Kit
10102032 (with All 4140 Solid Rod Ends)..... **410.00**

Ladder Bar Rear Clip
BASIC CLIP... \$1,015

Labels: Rear Spring Kit with Shocks, Panhard Bar, Narrowed 9" Ford Housing (Available with Back Brace), Welded Rear Subframe, Adjusting Link, Double Adjustable Ladder Bars.

2"x3" Welded Ladder Bar Clip	\$1,045.00
9" Housing with Brackets	960.00
AME Spring Kit for Above	165.00
Weld-On Panhard Kit for Above.....	95.00
Adjustable Ladder Bar Kit for Above.....	220.00
Solid 4140 and Poly Rod Ends	200.00
TOTAL	2,685.00
Package Discount	125.00
Package Price	\$2,560.00

As Shown **\$2,560**

and provides all the rigidity you'll need when roll cages and subframe connectors are employed. As a rule of thumb, the more rigid the chassis, the better it will work. The 2"x4" clips are perfect for use in street rod and truck applications, where roll bars and cages are not typically used. Here, the extra strength of the larger frame rails come into play.

32322000 2"x3" Welded L/B Bar Clip.....**\$1,045.00**
32322100 2"x3" Welded L/B Clip with "Donut" Crossmember.....**1,200.00**

32342000 2"x4" Welded L/B Clip with "Donut" Crossmember.....**1,585.00**

Complete Clip Package

Everything you see pictured above comes in this comprehensive package. Includes welded rear subframe, narrowed 9" rear end, Panhard Bar, Rear Spring Kit with 3-position Gabriel shocks and coil springs rate-matched to the application, plus Double Adjustable Ladder Bars.

Package Priced at.....**\$2,560.00**

LADDER BARS

Labels: Mounting Brackets, Crossmember, Diagonal Link, Morrison Spring Kit, Adjustable Mounting Brackets, 3-Position Gabriel Shocks, Optional Panhard Bar.

Adj Ladder Bar Kit w/4140 Ends	\$410.00
Ladder Bar Crossmember	70.00
AME Sprng Kit w/3-Pos. Gabriel Shcks ..	190.00
Weld-On Diagonal Link Kit	75.00
TOTAL	740.00
Package Discount	50.00
Package Price	\$695.00

Competition Package As Shown **\$690**
Street Package As Shown **\$725**

DeLuxe Double Adjustable Ladder Bars

Morrison Double Adjustable Ladder Bars are made from only the finest quality 1" O.D.x.156" wall D.O.M. seamless carbon steel tubing; rated at 80,000 psi tensile strength. Our list of features speak for themselves.

Our Ladder Bars are available in 30" and 32" lengths, measured from centerline of front pivot to centerline of axle housing. We offer our Ladder Bars bare or with combinations of standard 4140 solid rod ends, polyurethane-bushed stainless steel rod ends, or heavy-duty 4130 rod ends.

The Morrison "double adjustable" bars have a quick-adjust mechanism on the lower bar.

MORRISON

38



800-929-7188 • fax: 253-922-8847 • www.artmorrison.com

Rear End Housing Lateral Control



Panhard Bar Kits

Here's just what the doctor ordered for those situations where a rear end housing is out of the vehicle and being modified. This weld-on Panhard Bar kit includes tower mounts for the rear end housing and frame. The bar is fitted with polyurethane-bushed stainless steel rod ends.

12120327 (A) Weld-In Panhard Bar Kit..... \$110.00

Also available is a bolt-on Panhard Bar kit that attaches to a 9" housing with the 3rd member bolts. Chassis brackets are welded on. Includes all required hardware.

12120527 (B) Bolt-In Panhard Bar Kit (Attaches to Rear End Gasket Flng) ... \$150.00



The high mis-aligned Panhard Bar is designed specifically for applications such as air ride with significant rear end travel.

12120340 Weld-in High Mis-Align Panhard Bar Kit, 30" \$160.00

12120341 Weld-in High Mis-Align Panhard Bar Kit, 36" 160.00



Diagonal Link Kits

Morrison also manufactures a wide variety of diagonal link kits. They are available in both weld-in and bolt-on styles. Right hand/left hand rod ends provide easy adjustment. Your choice of 30" or 36" long links. Complete with all required hardware.

12120030 Weld-in Diagonal Link Kit, 30" \$75.00

12120036 Weld-in Diagonal Link Kit, 36" 75.00

12120430 Bolt-in Diagonal Link Kit, 30" 85.00

12120436 Bolt-in Diagonal Link Kit, 36" 85.00



Rear Wishbone Kits

For those competitors who wish to accurately position their rear-end housings, Morrison wishbones offer the ultimate in adjusting convenience. They are available made of 4130 chromoly tubing.

12120705 Rear Wishbone with 4130 Tubing..... 270.00



MORRISON

PERFORMANCE
AM
QUALITY

39

800-929-7188 • fax: 253-922-8847 • www.artmorrison.com

Popular Front Suspensions & Clips

Art Morrison Enterprises offers the industry's widest selection of front and rear suspensions, including air, coil-over and strut front setups and air or coil-overs for the rear. This ensures that you can obtain the best possible combination of performance and comfort for your particular vehicle. You should know that all Morrison suspension systems have been carefully computer-engineered to assure optimum operational efficiency—with the

front suspensions designed for "0" bump steer. These suspensions are available on bumper-to-bumper chassis, or subframe assemblies. The newest addition to the AME lineup, our exclusive Sport IFS front end, is designed for serious cornering, as is the C6 Corvette-based suspension. All Morrison front clips are CAD-engineered for the exact year/make/model vehicle and are custom made to your requirements.

FOR STREET RODS & TRUCKS
AIR SPRING

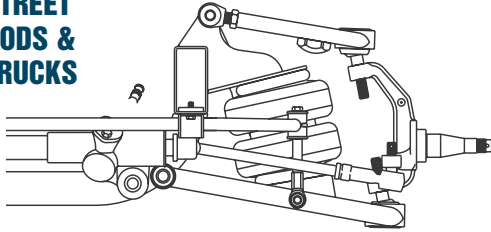

FOR RODS, TRUCKS & PRO STREET

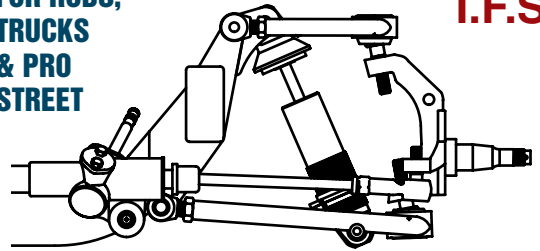

I.F.S.

FOR RODS & G-MACHINES
C6 VETTE

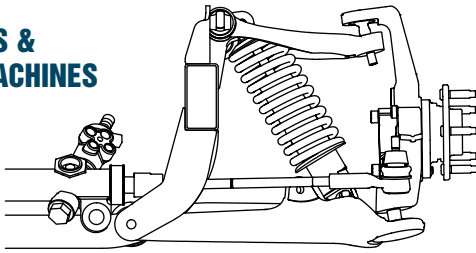

FOR RODS & G-MACHINES

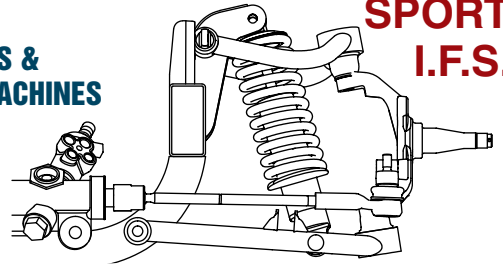

SPORT I.F.S.

Custom Made To Your Specs

SPORT C6

FOR G-MACHINES

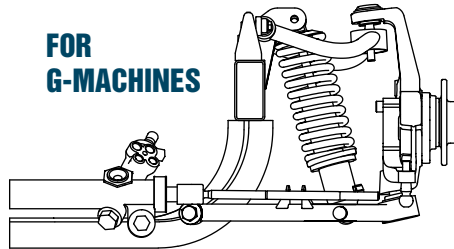

All Morrison Front Clips Are CAD-Engineered!

FRONT CLIP FRAME AVAILABILITY CHART

Frame Rail Size and Front Suspension Type

Price

Mandrel-bent .120" wall rectangular tubing

Fully factory welded 2"x4" clip, set up for Morrison IFS	1,515.00
Fully factory welded 2"x4" clip, set up for air ride front suspension	1,705.00
Fully factory welded 2"x4" clip, set up for C6 Corvette front suspension	1,810.00
Fully factory welded AME GT Sport '67-'81 Camaro	3,455.00

MORRISON

40



800-929-7188 • fax: 253-922-8847 • www.artmorrison.com

AME I.F.S.

Narrow Track I.F.S.

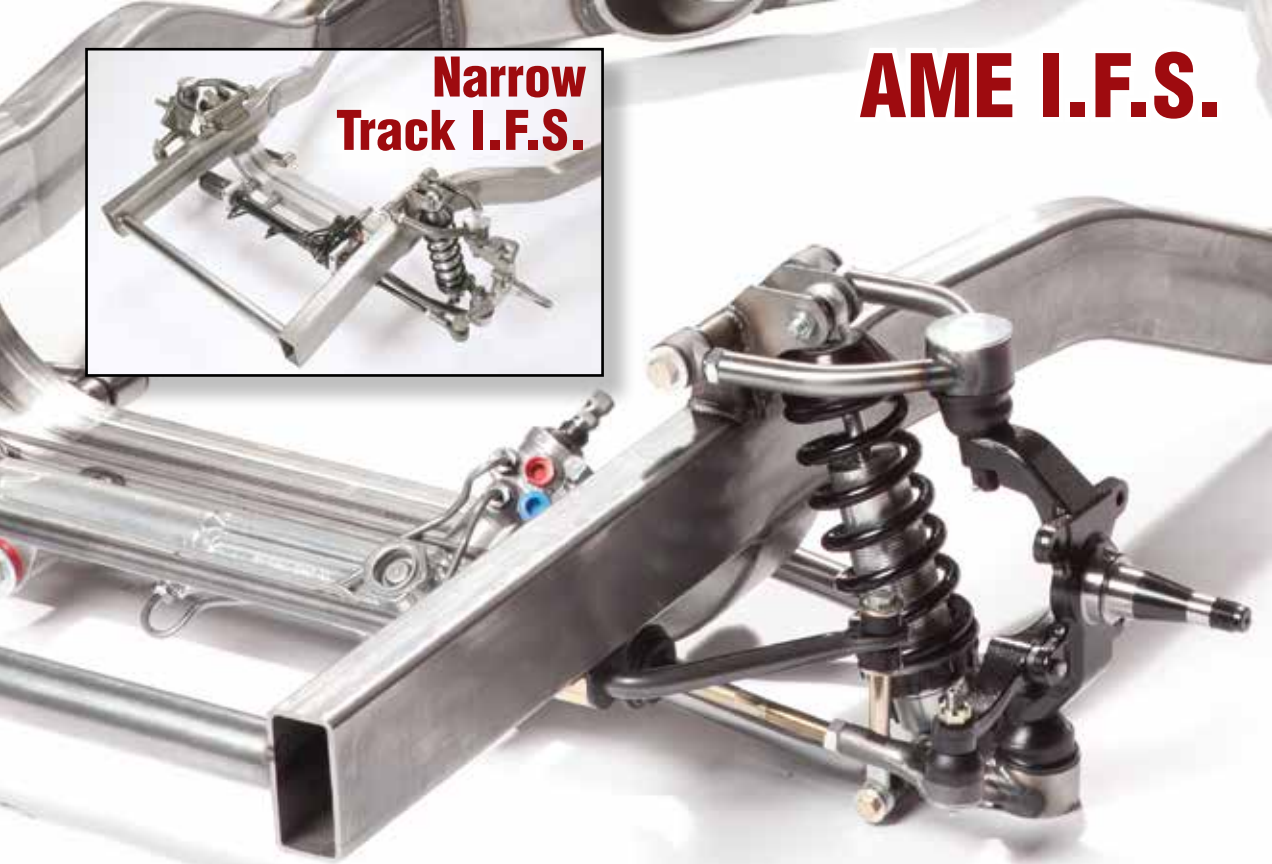

Proven To Be The Very Best I.F.S. Value On The Market!

Morrison has created the "ultimate" I.F.S. (Independent Front Suspension) for the serious street enthusiast. Design features include beefy control arms, Aldan or Strange adjustable poly bushed coil-over shock absorbers with urethane bushed mounts and sculptured towers. Its attractive styling makes it a handsome addition to any street rod.

Most importantly, the geometry for the Morrison DeLuxe I.F.S. has been perfected through computer analysis and engineered for "0" bump steer. It provides you with excellent vehicle control, as well as a superb, comfortable ride under a wide

range of road conditions.

The heavy-duty control arms are made from beefy 7/8" o.d. (upper) and 1-1/8" o.d. (lower) tubing, and available with chrome plating for lasting durability and exceptional good-looks.

Complete weld-in assemblies including 2"x4" subframe, power rack, tie rod ends, spindles, unplated upper & lower A-arm kits, sway bar and Strange coil-overs package priced at **\$4,129.00**; with polished chrome upper & lower A-arms **\$4,629.00**. Brakes not included in package, see below.

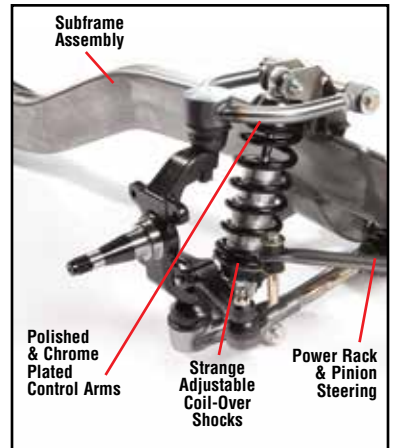

86820950	Welded Subframe Assembly, 2"x4"	\$1,515.00
86835110	Tie-Rod Ends (each).....	.25.00
830108320	Wilwood Pro Spindles325.00
86835129	Manual Rack.....	.310.00
86835090	DSE Power Rack.....	.565.00
86803000	I.F.S. Swaybar Kit.....	.190.00
86801950	Upper A-Arm Kit - Polished Chrome (with Ball Joints, Caps and Poly-Bushed Rod Ends).....	.675.00

86802950	Lower A-Arm Kit - Polished Chrome (with Ball Joints, Caps and Poly-Bushed Ends).....	.750.00
86801960	Upper A-Arm Kit - Bare Metal (with Ball Joints, Caps and Poly-Bushed Rod Ends).....	.440.00
86802960	Lower A-Arm Kit - Bare Metal (with Ball Joints, Caps and Poly-Bushed Ends).....	.455.00
	Strange Coil-Over Shocks with Springs (pair).....	.524.00



800-929-7188 • fax: 253-922-8847 • www.artmorrison.com

MORRISON
PERFORMANCE
AM
QUALITY



AME Sport I.F.S.

Engineered For Those Who Are Serious About Corners!

While the tried and true AME IFS has proven its merit on many a winding road and test track, there are those who want to push the envelope farther. So for the serious corner carver, we've developed the AME Sport IFS.

The most visible difference is the use of large tube control arms, going from the 7/8" OD upper used the standard IFS to 1" diameter. This provides additional stiffness without any appreciable weight penalty (it's much lighter than any OEM A-arm) and is designed to allow use of large front tires. Larger polyurethane bushings are also employed, which serve to reduce noise and vibration while minimizing flex.

What's not readily visible are numerous enhancements to the suspension geometry that are engineered for more aggressive driving. For example, anti-dive is set to minimize nose-diving during hard braking, caster is increased for more stable highway

manners, and camber gain has been optimized to utilize more of the tire's footprint in contact with the pavement for improved stopping. Roll center movement is less than 3" laterally, which provides confident transitional handling comparable

to contemporary high performance vehicles.

Clearly, the AME Sport IFS is ideally suited to high performance G-Machines that are "Track Day" worthy.

For more details, including adaptability to various applications and pricing info, call AME's tech staff for personalized assistance.



MORRISON

42



800-929-7188 • fax: 253-922-8847 • www.artmorrison.com



AIR SPRING PLUS



Air Spring Front Clip Package

For those applications where the builder wishes to adapt a Morrison Air Spring+Plus™ suspension to an existing chassis, special front subframe assemblies are available. Like all other Morrison frame components, the subframes are individually CAD-engineered for the year/make/model vehicle and the rails are mandrel-bent to form “show quality” bends.

The subframes are made of 2"x4"x.120" wall rectangular tubing, and fixture-welded by Morrison's staff of experienced craftsmen to assure proper alignment of critical suspension components.

Air Spring+Plus™ suspension packages are available individually for front subframes. The air springs, hoses, fittings,

air pump, storage tank and dash-mount control panel (single switch) come as a package, while the front suspension—control arms, sway-bar, and shocks. It pays to buy necessary related items at the same time.

Our typical air front clip package, shown above for **\$4,285.00**, contains a custom CAD-designed 2"x4" firewall-forward subframe, tubular control arms with Air Spring+ mounts, shock absorbers, sway-bar, DSE Power rack, spindles, and springs.

AIR2100 Factory-Welded 2"x4" Front Subframe "Clip" for Air Spring+Plus™ Suspension.....	\$1,710.00
86835210 Wilwood Pro Spindles	325.00
86835120 Flaming River Rack (manual)	310.00
86835090 DSE Power Rack	565.00



Truck Front & Rear Suspension Kits

You can update the chassis of your 1947-53 Chevrolet pickup in logical stages through the use of these kits offered by AME. This is especially beneficial for builders on a budget, as the chassis modifications can be made in sequence with minimum "down time." You won't have to remove the body from the OEM frame. It's the easy way to enjoy improved handling and ride with your classic pickup truck!

Build It In Stages!



1 FRONT CROSSMEMBER KIT

Designed to be "spliced" into a stock 1947-53 Chevy truck chassis, the kit consists of a front crossmember that contains steering, lower control arm and motor mounts, upper control arm/coil-over mounts, tubular upper and lower control arms, ball joints, spindles, adjustable anti-sway bar, Strange adjustable coil-over shocks, and a power rack & pinion steering. Plates are employed to "box" the frame and support the crossmember. The assembly is CAD engineered for the application and provides contemporary handling and ride.

2 BRAKE PEDAL KIT

An elegant solution for adapting a Wilwood master cylinder and proportioning valve to your 1947-53 Chevrolet truck. The assembly features an precisely engineered bracket for the pedal (with a stop), master cylinder and proportioning valve and uses the original floorboard opening. The mounting plate can be bolted into position or welded. It also serves to stiffen the frame. Also available with a clutch pedal for stick shifts.

3 REAR SUSPENSION KIT

Adapting a hefty 9" rear end housing and 4-bar rear suspension to your 1947-53 Chevy truck is easy with this superbly engineered kit from AME. It starts with a 2x6 crossmember that includes mounting brackets for the four bars (which have poly-bushed stainless steel rod ends). A tubular crossmember, with upper coil-over mounts, is attached to the frame using four brackets that also serve to reinforce the rails. The 9" housing is made to your desired width and fitted with mounts for the coil-overs and 4-bar suspension. Strange adjustable coil-over shocks and a lateral stabilizer bar (with mount) complete the package.

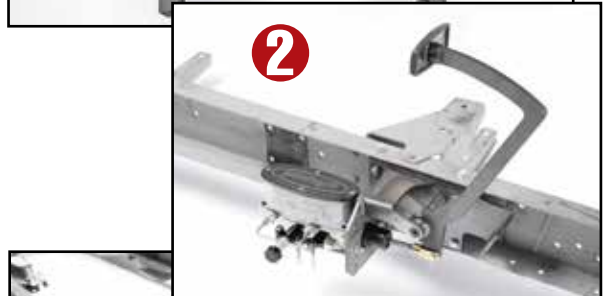
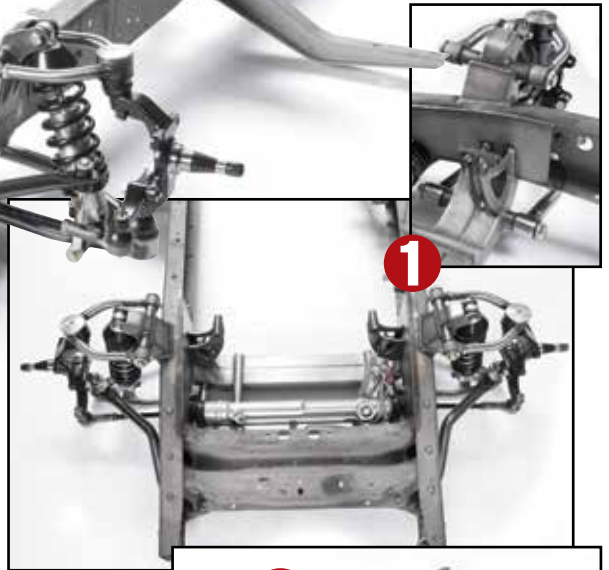

MORRISON

44



800-929-7188 • fax: 253-922-8847 • www.artmorrison.com



Weld-In I.F.S. Kits

As Shown
\$3,179



It's easy to gain the benefits of an independent front suspension with this convenient weld-in kit. It contains a mandrel-formed 2"x4" rectangular steel crossmember with fixture-welded steering

(use Maval rack) and lower control arm attachments, upper mounts, tubular control arms, ball joints, linkage and all required hardware. The IFS is designed to accommodate Wilwood spindles. Aldan or

Strange coil-over shocks can be used with this setup. The kit is engineered to fit stock frame rails and can be installed by do-it-yourself home builders.

I.F.S. WELD-IN KIT, COMPLETE

I.F.S. Weld-In Crossmember and Control Arms.....	\$1,555.00
<i>(basic kit as shown at right)</i>	
Tie Rod Ends.....	50.00
Power Rack, DSE.....	565.00
Strange Shocks w/Springs.....	524.00
I.F.S. Sway Bar Kit.....	190.00
Spindles.....	325.00
How-To Video.....	20.00
TOTAL.....	3,229.00
Package Discount.....	50.00
Package Price.....	\$3,179.00



As Shown
\$1,555

AME Weld-In Crossmembers Available In Six Popular Widths

Art Morrison Enterprises offers weld-in front crossmembers in a variety of widths. To determine which is best suited to your car or truck, you'll need to determine the distance

from the outside of the right frame rail to the outside of the left frame rail. This distance is shown on the left side of the adjacent chart. On the right side of the chart you'll see the track

width for the corresponding assembly. Track width is determined from hub-to-hub. Please also consider wheel size and offset when determining width.

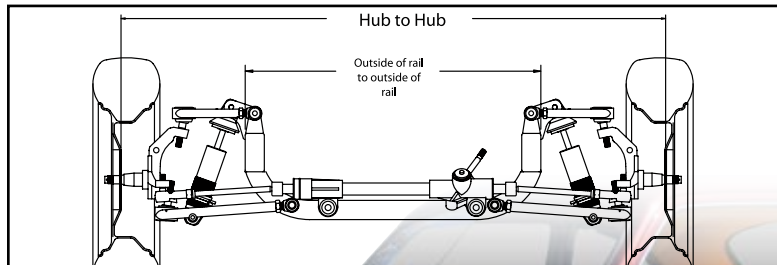

Based on 4" High Frame	
Frame O/S to O/S	Track Width
22"	.48"
28"	.54"
28"	.57"
31"	.57"
31"	.60"
34"	.62"



Build In Stages! EASY AS 1-2-3

Many builders don't want to deal with taking a body completely off the frame, or simply prefer to do the chassis modifications on a smaller scale. That's why Art Morrison Enterprises has developed the "knock-down frame package." You can adapt these sections to your existing frame one by one and ultimately enjoy the benefits of a contemporary suspension. Get improved handling and a better ride in three easy stages. Please note that the Center Support and Tri 4-Bar rear are designed to use a through-frame exhaust system. This will allow you to have a lower stance while providing ample ground clearance. All in all, this is the best way for many builders to go about constructing a first class ride.



Eric Brockmeyer used a custom front clip to nail the stance on his 1962 Rambler American sedan.



\$5,768
**2x4 Knock-Down
Frame Package**

1 TRI 4-BAR REAR

Our triangulated 4-bar rear suspension can easily be adapted to most vehicles and provide outstanding acceleration and lateral control. The kit includes the poly-bushed link bars, crossmember, 4-bar mounts for the rear end housing and frame, shock mounts, sway bar and coil-over shocks.

2 CENTER SUPPORT

Here's the easy way to stiffen your chassis for improved handling while providing convenient through-frame routing for the exhaust. This facilitates a lower stance without worrying about mufflers hanging below the frame. The mandrel-formed 2"x4" tubes can easily be trimmed to fit most any frame.

3 BIKINI CLIP

Remove the front crossmember section of your frame and insert an AME "Bikini clip" just behind the OEM core support and in front of the kick-up. Your choice of an IFS with coil-overs or an Air Spring-Plus suspension. CAD engineered to fit your application. Clip and suspension available separately.

Front Bikini Clip	\$3,699.00
Center Frame Kit w/3" Exhaust.....	390.00
2"x4" Xmbr w/Donut w/3" Exhaust...	405.00
Tri 4-Bar Suspension Pkg.	1,524.00
TOTAL.....	6,018.00
Package Discount.....	250.00
Package Price.....	\$5,768.00

Start With A Fully-Welded Bikini Clip Package



As Shown \$3,574

For many applications, employing an Art Morrison "Bikini Clip" represents the easiest way to adapt a contemporary front suspension and power steering to an older car. The "Bikini Clip" is designed to be spliced into a section of the host frame, and not disturb key elements of the OEM chassis. You can save money with AME's package price, or buy the components on an individual basis.

Bare Welded Bikini Clip.....	\$1,340.00
Wilwood Pro Spindles	325.00
Strange Front Coil-Overs.....	524.00
DSE Power Rack	565.00
IFS Upper/Lower Control Arms	895.00
Tie-Rod Ends	50.00
TOTAL.....	3,699.00
Package Discount.....	125.00
Package Price.....	\$3,574.00

MORRISON



Wilwood Pro Front Spindle

New Premium Quality Forged Steel Assembly Is The Perfect Replacement For Mustang II



The venerable Mustang II front spindle has been a staple in I.F.S. setups for street rods and street machines. But as anyone who has had to use the OEM Mustang II

unit, and aftermarket copies knows, there are shortcomings. That's why AME has collaborated with Wilwood Engineering in the development of this new spindle that should prove to become the standard of the industry.

It's made from a high strength steel forging and heat-treated to provide increased levels of durability. The forgings are CNC-machined to exacting tolerances, and incorporate important design features. The unit is taller than the OEM Mustang II to provide improved geometry. There is a greatly reduced roll center migration. And the unit

has been designed to accommodate radial mount calipers and rotors up to 14" diameter. A bolt-in retrofit for existing Mustang II units, it's the answer for anyone wanting to equip their ride with serious braking power, while improving handling.

83098070 Wilwood Pro Spindle - 2" drop.....**\$325.00**
830108320 Standard Height Spindle**\$325.00**



Coil-Over Shock Absorbers

Strange Engineering Coil-Over Shocks

Strange aluminum adjustable coil-over shocks are designed to take the guesswork out of tuning your suspension. Whether you are adjusting the ride of your street machine or fine-tuning a drag race vehicle, Strange shocks are a valuable tool to adapt your suspension to the changing conditions your vehicle will encounter. Proven to be exceptionally effective and reliable on our own "Project GT55" Chevy...which has recorded some remarkable skid pad, slalom and acceleration numbers.

Strange Engineering single adj. Coil-Over shocks w/springs available from (pr)...**\$510.00**
 Strange Engineering double adj. Coil-Over shocks w/springs available from (pr)...**\$730.00**

AME Street & Competition Coil-Overs

Art Morrison Enterprises' own coil-over shocks represent one of the best suspension values in the industry. These highly effective units feature a 3-position Gabriel shock that is fitted to a unique spanner-adjustable base with your choice of polyurethane bushings or spherical bearings.

The poly-bushed "Street" units provide quiet operation, as there is no metal-to-metal contact as you get with "Competition" style coil-overs equipped with spherical bearings. The "Competition" units provide more positive control than the more flexible poly-bushed units.

Both types are shipped with coil springs that are rate-matched for your vehicle. All are priced at **\$260.00** (pair), and include special mounting tabs.

To make installation of these coil-overs easy, use Morrison's handy Shock Jigs. See page 47 for details.

Morrison Rear Spring Kit Assemblies

They are approved by NHRA and IHRA for use in S/S as a legal replacement (for cars originally equipped with coil springs). "Traction Tuned" package includes coil springs rate-matched for the application and 3-position adjustable shocks. They provide up to 4" of ride height adjustability, and the mounts are contoured to fit 3" housing tubes. An AME innovation. **\$190** (pair)



Single Adjustable \$510
Double Adjustable \$730

Street • Competition • Spring Kit



MORRISON

PERFORMANCE
AM
 QUALITY

47

800-929-7188 • fax: 253-922-8847 • www.artmorrison.com

JRi Hydraulically Adjustable Shocks

JRi Shocks is proud to introduce their new Patent Pending Hydraulic Ride Height System. Unlike typical systems that operate with air, JRi's Ride Height System is 100% hydraulic, working directly upon the coilover spring. It features 2" of ride height adjustment all while retaining the ride and performance benefits of a coilover shock.

Traditional air ride systems are sufficient for lowering your car for a show but come with several deficiencies; air is inconsistent, it changes dramatically with temperature and elevation thus affecting handling and performance. Over time, seals will weather and eventually leak leading to decreased performance.

The state of the art JRi Ride Height System uses a coilover spring with a hydraulic weight jacker allowing you to

raise and lower your vehicle instantly by way of a hydraulic pump. Combining the Ride Height control you want with the

performance of the ultimate shock absorber gives you the whole package; performance, ride quality and ride height.



JRi Shocks



We are always on the lookout for new products that will improve performance, and we've found it with JRi shocks. The company has taken shock absorber technology to the next level from both a design and manufacturing standpoint.

For example, the shafts are REM finished to provide a low friction, high pressure seal, which results in more stable tire contact. A "floating" seal/bearing head neutralizes side loading to the shaft that is common to coil-over applications, with the energy dissipated through the fluid and not the friction of components. The design and function of the main piston and shim allows the shock to stay more closely in phase with the varying frequencies created by the tire and provide more consistent damping. And there's more.

You should also know that many of the nation's leading race teams have switched to JRi shocks. These range from NASCAR, NHRA and SCCA champions to Formula Drift standout Vaughn Gittin, Jr., whose awesome Mustang was on our last cover.



Double Adjustable Remote Reservoir



Double Adjustable



Non Adjustable



Single Adjustable

We carry a variety of JRi shocks to suit your application and budget. These include non-adjustable, single, double, triple and quadruple adjustable units. JRi is also developing non-adjustable units specifically for our various GT Sport chassis packages that will provide awesome handling and no-hassle convenience. Call for tech details and pricing information on the JRi line.



Vaughn Gittin, Jr. Mustang

9" Rear End Housings

Triangulated 4-Bar F9 Housing

The 9" rear end housing has become a "standard" in world of high performance. Its beefy 9" diameter ring gear has proven to be capable of handling even supercharged engines with outstanding reliability. What's more, there are more rear end gear sets made for the 9" than any other differential, with ratios from 2.63 to 6.50 available. As such, the 9" can be used in everything from street rods to all-out competition vehicles.



\$1,330

Art Morrison Ent. has made a "science" of preparing 9" housings to fit your needs. We have developed special fixtures that allow our technicians to hold all components in correct alignment when fitting the housings with new tubes and billet housing ends. Subsequently each unit is narrowed to your requirements and equipped with all required suspension brackets and other options, such as a reinforcing brace, filler bung, etc. Some of our most popular setups are listed below. Call for details on other combinations.

Street or Competition Big Web 9", narrowed to your specs and equipped with choice of rear end housing end bolt pattern, filler bung & all required suspension brackets... **\$960.00**

Super Clip 9", narrowed as required, fitted with 1-piece back brace, suspension brackets, lateral supports, filler..... **1345.00**

Air Spring Big Web 9" narrowed to your specs and equipped with your choice of housing end bolt pattern, & includes all required brackets for an Air Spring Suspension **960.00**

Air Spring Housing



\$960

4-Link Housing



\$960

Super Clip Housing



Shown w/Opt. Panhard Bar Mount **\$1,345**

4-Bar Housing



\$960

Triangulated 4-Bar Housing



\$1,000

3-Link Housing



\$1,160

Triangulated 4-Bar Housing w/Brace



\$1,185

Super Car Housing



\$1,410

Leaf Spring Housing



\$810

Ladder Bar Housing



\$960

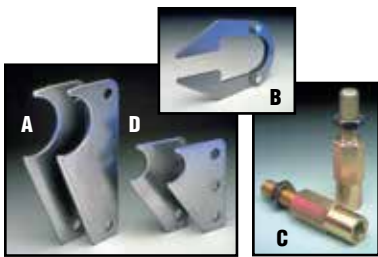

Ladder Bar Replacement Parts

A complete assortment of premium quality components are available to facilitate ladder bar installations and upgrades.

- 10851710 (A) Ladder Bar Housing Plates, 5/8" Holes (4).....\$40.00
- 10851800 (B) Lddr Bar 360° Frnt Brace Kit\$30.00
- 10851900 (C) Ladder Bar Adjuster Kit.....\$50.00
- 11852010 Crossmember Bare Tube.....\$40.00
- 11852100 Lddr Bar Frnt Mntng Plates (4).....\$40.00
- 11852110 (D) Ladder Bar Front Mounting Plates, 5/8" Holes (4).....\$40.00
- 11852210 Lddr Bar Frnt Mount. Plates, 2"x3".....\$40.00

Adjustable Coil-Over Shock Housing Mounts



Add ride height adjustability to any AME coil-over shock installation. Allows optimum shock positioning to prevent binding through full suspension travel. Provides 6-1/2" adjustable range. Complete kits, L-Bracket kits or individual brackets for spherical or poly-bushed rod ends. Coil-Over Housing Mount Kit (brg. or poly) (Pair) ...\$30.00 L-Bracket Kit, (Bearing or poly - pair).....\$50.00 L-Bracket Only (Brg. or poly, left or right - Each).....\$15.00



Upper Shock Mounts

This versatile kit makes it easy to make upper shock mounts that accommodate Koni, Afco & other racing units. Includes a tube, brackets and all required shock-mounting hardware.

- 18182500 Aldan, Afco, Koni Upper Coil-Over Mount Kit.....From \$50.00



800-929-7188 • fax: 253-922-8847 • www.artmorrison.com



Rear Coil-Over Springs

Use these fixed rate or variable rate springs to "dial in" a race car's suspension for improved traction. Available in six increments from 80# to 200# or 160-250# variable rate spring that gets stiffer as the spring compresses.

- 16163000 80# Fixed Rate 2-1/2" I.D.x12" Rear Springs (Pair).....\$130.00
- 16163100 95# Fixed Rate 2-1/2" I.D.x12" Rear Springs (Pair).....\$130.00
- 16163200 110# Fixed Rate 2-1/2" I.D.x12" Rear Springs (Pair).....\$130.00
- 16163300 130# Fixed Rate 2-1/2" I.D.x12" Rear Springs (Pair).....\$130.00
- 16163400 150# Fixed Rate 2-1/2" I.D.x12" Rear Springs (Pair).....\$130.00
- 16163600 200# Fixed Rate 2-1/2" I.D.x12" Rear Springs (Pair).....\$130.00
- 16163700 250# Fixed Rate 2-1/2" I.D.x12" Rear Springs (Pair).....\$130.00



Coil Spring & Shock Absorber Bearings

Install these spring bearings under each spring for adjusting ride height easily. Roller-type bearings permit adjuster to turn freely by eliminating spring friction.

- 18166400 Spring Bearing Kit Poly (Pr).....\$14.00
- 18166100 Shock Bearing Kit (brngs & snap rings ..\$36.00
- 18166200 Snap Rings (8).....\$5.50



Coil-Over Mounts

Designed to mount a coil-over rear spring suspension with a 4-bar rear suspension.

- 14153625 Crossmember & Upper Mounts (kit).....\$55.00
- 14153620 Lower Coil-Over Shock Mount (kit)\$145.00

AME Front Springs

Specifically designed for use on Morrison chassis, subframes and struts assemblies. Five different rates to choose from. NOTE: AME carries a wide range of springs for numerous applications. Please call our sales/tech dept. for info on other spring rates not listed.

- 16161805 170# Fx'd Rate 2-1/2" I.D.x10" Sprngs (Pr) \$130.00
- 16161815 250# Fx'd Rate 2-1/2" I.D.x10" Sprngs (Pr) ..\$130.00
- 16161820 350# Fx'd Rate 2-1/2" I.D.x10" Sprngs (Pr) ..\$130.00
- 16161855 550# Fx'd Rate 2-1/2" I.D.x10" Sprngs (Pr) ..\$130.00
- 16161865 650# Fx'd Rate 2-1/2" I.D.x10" Sprngs (Pr) ..\$130.00

AME Rear Spring Kit

Morrison rear spring kits (#18180000) require a larger spring than AME coil-overs. They are available in six different rates, and are priced per pair.

- 16182000 90# Fixed Rate 3" I.D.x14" Springs...\$110.00
- 16182500 110# Fixed Rate 3" I.D.x14" Springs...\$110.00
- 16183000 130# Fixed Rate 3" I.D.x14" Springs...\$110.00
- 16183400 145# Fixed Rate 3" I.D.x14" Springs...\$110.00
- 16183500 165# Fixed Rate 3" I.D.x14" Springs...\$110.00
- 16184000 200# Fixed Rate 3" I.D.x14" Springs...\$110.00



Shock Jigs Kits

These handy new devices from Art Morrison make it easy to install a rear end housing in the correct position for your desired ride height. The Jigs can be set for the compressed height of the coil-over, and shock mounts positioned accordingly. Models are available to simulate both spherical bearing end and standard shaft-type shocks. The shock jigs are shown with Morrison coil spring mounts for illustrative purposes. \$30.00

Replacement Shocks for AME Rear Spring Kits and Coil-Over

These are replacement shock absorbers for Gabriel-based Morrison coil spring kits. The Gabriel shocks are of the heavy-duty Strider variety sporting 3 valve positions to allow ride adjustability. A companion to Morrison coil-over springs shown at the top of this page. Sold individually. \$40.00





"Tee" Bolt Kit

Secure backing plate to housing or spindle flange with these premium quality "Tee" bolts. Includes bolts and aircraft style lock nuts.

40401030 3/8" (Set of 8)\$40.00
 40401020 1/2" (Set of 8)50.00



Housing Breather Kit

Eliminate those pesky leaks that 9" housings are known for. This "catch can" mounts above the housing. Excess pressurized gear oil goes to the tank, is vented, and the oil drains back after parking.

40403020 Housing Breather Vent for Hose\$15.00
 40403030 Housing Vent Tank45.00

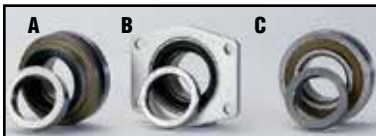

H-D Axle Bearings

H-D ball-style axle bearings are pre-lubed & sealed for easy installation and long life. Mopar bearings fit 8-3/4" & Dana 60 applications and eliminate need for pre-load adjustment. From \$40.00 ea.

(A) 46460125 Set 20, 1.562"\$50.00
 (B) 46460130 Small Ford Conv50.00
 (C) 46460300 '57-'64 BOP50.00
 (D) 46460120 1.562" Ball Bearing50.00
 (E) 46460110 1.772" Ball Bearing50.00
 (F) 46460000 Mopar w/Retainer50.00



1-Piece Mandrel Bent Housing Back Brace

Designed for any rear end that will be subjected to severe shock loads. Not only will the brace help maintain a straight housing, but it will facilitate increased bearing life. Made from a single mandrel-bent piece of tubing to ensure optimum structural integrity. Should be installed during or before narrowing the rear end to ensure proper axle alignment. Available for 9" and 8-3/4" Mopar applications. \$80.00



2-Piece Back Brace For Hot Rod Housing

Designed for those who wish to strengthen a small web 9" Ford or 8-3/4" Mopar housing and improve its looks, AME's back brace kits consists of two formed and sculpted sections that you weld onto the housing \$80.00



Wheel Spacers

Installing wider tires and wheels can often lead to clearance problems. Solve them with our aluminum spacers (5-on 4-1/2", 4-3/4" & 5").

54020500 1/8" W 7/16" Holes, Each\$18.00
 54020510 1/8" W 1/2" Holes, Each18.00
 54020520 1/4" W 7/16" Holes, Each22.00
 54020530 1/4" W 1/2" Holes, Each22.00
 54020540 1/2" W 7/16" Holes, Each30.00
 54020550 1/2" W 1/2" Holes, Each30.00

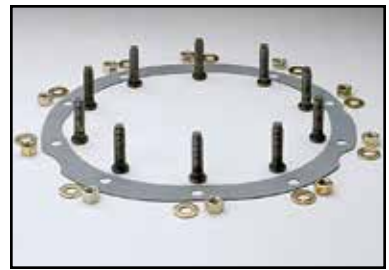

Carrier Installation Kit

Here's just what the doctor ordered to do a first class job of installing a 9" carrier in the rear end housing. Included in the kit is a special high performance gasket, plus premium grade bolts, nuts and lock washers. Pesky leaks will be a thing of the past when you use this special kit.

40401015 Carrier Installation Kit\$40.00



Leaf Spring Mounts

Use our universal housing mount pads when installing a new rear end in your leaf spring car. Fits 2-1/2" wide springs. \$20.00 per pr.



Strange Engineering Thirdmembers

Strange 9" S-Series Iron center section fully assembled with posi-unit, Daytona iron pinion support, 3.00-6.50 Strange standard gear set and S-Series steel (1350) yoke. Call for options & other 3rd member choices. From \$1,240.00





Housing Ends

We offer a complete selection of housing ends for all applications. Please refer to the handy reference chart below to assist you in identifying housing flanges. They include our own Morrison CNC-machined billet steel ends (as pictured above).

Billet Housing Ends for 9"\$100.00



Caps and Plugs

Finish off your rear end housing or tank with these handy filler cap and bung assemblies. The cap is aluminum while the bung, flange and pipe plug are made of steel.

92851300 Rear End Filler Cap & Bung (A).....\$34.00

92851600 1/2" Flange & Pipe Plug Set (B).....10.00



Bearing Retainers

An ideal replacement for stock-type units, our bearing retainers offer substantially greater strength and ease of installation/removal. Made from 3/16" steel. They are available for the most popular applications. Please call for details regarding your housing. \$30.00 pair

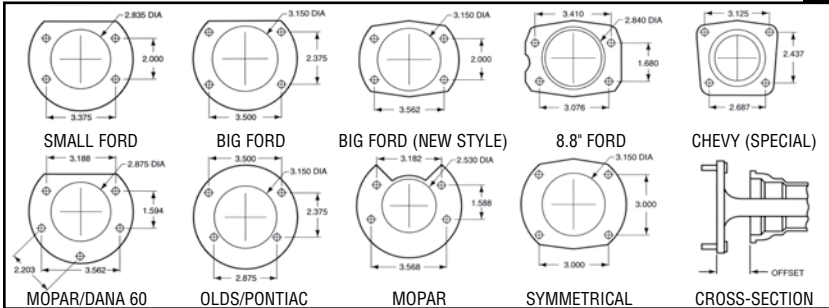

Strange Engineering Axles

Strange Engineering Hi-Tuff forged steel axles and spools are the answer for reliability on the drag strip. They are available custom-made in any length, spline and bolt pattern, with a 2-year warranty on 33 or more splined axles. Companion spools available. For street applications, we also offer Strange's popular new "S/S" (31-spline) and "S/T" (35-spline) induction hardened axles.

Hi-Tuff Race Axles (to 35-spline)

Pair.....call for pricing

S/S Street Axles (31-spline) Pair.....\$335.00

S/T Street Axles (35-spline) Pair.....335.00

NOTE: Strange 40-spline racing axles and spools are also available. Please call for pricing information.



Wilwood & SVO Rear Disc Brake Kits With Parking Brakes & Drum Brakes



Wilwood "Big Brake" Kit

Superior stopping power is assured through use of the Wilwood "Big Brake" kit, which features 4 piston caliper with a drum-style parking brake. Choice of 13" or 14" rotors 13" priced from \$1,510.00 14" priced from \$1,635.00

DynaLite Pro w/Internal Park

Wilwood's highly regarded Forged DynaLite 4 piston disk brake with an effective "in the hat" internal shoe parking brake assembly. From \$660.00.



Drum Brake Kit

Our rear drum brake kit for 5-on 4-1/2" or 4-3/4" bolt circle patterns comes with fully assembled backing plates. Fits 9" Ford housing with big ends. Includes new drums, 11"x2-1/2" shoes, wheel cylinders & hardware. \$565.00

SVO Rear Disc Kit w/E-Brake

Kit features heavy-duty 11" rotor rear disc brakes, and inside the "hat" resides a highly effective drum brake. Complete kit from \$545.00

MORRISON

52



800-929-7188 • fax: 253-922-8847 • www.artmorrison.com

Aero 6 Front Brake Kit

This innovative front brake kit features a 6-piston caliper and big 14.25" slotted vented cast iron rotor for optimum swept area. Fits C6 Corvette spindles. From **\$1,835.00**



Superlite 6 Big Brake

Billet SL6 calipers come with an aluminum hat, mounted 13" vented iron rotors, and forged aluminum hubs. A powerful and compact braking system. From **\$1,605.00**



Wilwood C5/C6 Front Brake Kit

The perfect mate to chassis with C5/C6 front suspensions. Choice of 13" or 14" rotor, 6 piston caliper. 13" priced from **\$1510.00**. 14" priced from **\$1640.00**



H-D Pro Series Front Kits

For vehicles weighing over 2800 lbs. the heavy-duty setup is recommended. It comes with a big 10.750" diameter (.810" thick) rotor for rapid heat dissipation and Dynalite 4-piston calipers, plus everything required to complete the installation. **\$695.00**. Optional for this kit are polished billet calipers. With 12.19 rotors. From **\$785.00**



C6 Rotor & Caliper Kit

C6 rotor and caliper kit comes with right hand & left hand. 13" rotors, Corvette calipers, brake pads, and hardware.

40432731 Vet C5 13" Rotor and Caliper Kit.....**\$980.00**

Wilwood Carbon Ceramic Brake Kit

The space-age braking technology found on the ZR1 Corvette can be yours with Wilwood's new carbon ceramic brakes. Extra light rotors reduce unsprung weight for better handling and are very long-wearing. Call for pricing and applications.



Disc Brake Conversion

Put 11" Ford brake rotors and GM calipers on OEM or aftermarket Mustang II spindles. Includes adapter brackets, new brake rotors, calipers with pads, bearings, seals, dust caps and hardware. Spindles and brake lines NOT included. **\$585.00**. Available in 5-on 4-1/2" or 5-on 4-3/4" patterns.





Emergency Brake Cable Kits

Designed for use on Wilwood rear brakes with built-in parking brake. Choice of black or braided stainless steel cable housings.

E-brake cable kit (black sheath) \$160.00
E-brake cable kit (stainless sheath) 230.00



Wilwood Master Cylinder

Aluminum tandem chamber Master Cylinder, die cast, premium alloy with black anodized billet lid. Designed for a wide range of custom manual or power brake applications.

26011190 M/C Combination Volume Line and Bracket Mount Kit \$135.00
26085550 Hi Vol. Tandem 1" Bore M/C 210.00
26085552 Hi Vol. Tandem 1" Bore M/C Bri 250.00
26094390 Hi Vol. Tandem 7/8" Bore M/C 210.00
26094392 Hi Vol. Tandem 7/8" Bore M/C Bri 250.00



Hi-Temp Brake Fluid

Specially developed for racing. Has a minimum dry boiling point of 570°—substantially higher than DOT 3 or 4 requirements! Also designed to lubricate and clean brake system internal parts. Has a very low viscosity, which facilitates easy bleeding of brakes and eliminates problems of fluid foaming from excessive pumping.

29006320 Wilwood Hi-Temp 570° Fluid, 12 Oz... \$10.00



Precision Residual Pressure Valves

Maintains pre-set pressure in drum brake setup and positive caliper action in disk brake systems. Especially helpful in installations where the master cylinder is mounted low on the chassis.

26032780 2-lb. RPV with Fittings \$24.00
26032790 10-lb. RPV with Fittings 24.00

TECH TIP: Brake Systems

In setting up the brake system for a race car or street machine there are several important factors to consider. These include pedal ratio, required master cylinder pressure & volume, front-to-rear balance and how they relate to the disc or drum setups to be used. You can call Morrison's experienced Tech Staff for help in getting the right parts for your application.

MASTER CYLINDER PRESSURE

Pedal Ratio	3/4" Bore	7/8" Bore	1" Bore	1-1/8" Bore
3:1	1023 psi	750 psi	570 psi	455 psi
4:1	1364 psi	1000 psi	759 psi	606 psi
5:1	1705 psi	1250 psi	949 psi	758 psi
6:1	2045 psi	1500 psi	1139 psi	909 psi
7:1	2386 psi	1750 psi	1329 psi	1061 psi
8:1	2727 psi	2000 psi	1519 psi	1212 psi

Adjustable Proportioning Valve

Set the proper front-to-rear brake balance with this handy in-line Proportioning Valve. Ideal for both disc/disc and drum/disc setups. Includes Wilwood Proportioning Valve and the fittings to facilitate installation. For racing or street use.

26084190 Wilwood Brake Proportioning Valve... \$50.00



M/C Mounting Brackets

AME manufactures several mounts that accommodate the popular Mopar tandem master cylinder. They are made of 5/16" steel plate, to fit round tube or 2"x3" frames, and come with gusset. A bracket-style unit that is designed for use on a crossmember (use w/Morrison SuperCar) is also available.

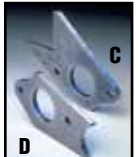

32555811 (A) Tri-5 Master Cylinder Adapter Plate \$15.00
52496300 (B) Chrysler Master Cylinder Mount for SuperCar Chassis 30.00
52496200 (C) Chrysler Master Cylinder Mount Square Tube Chassis 22.00
52496100 (D) Chrysler Master Cylinder Mount Round Tube Chassis 22.00



Tandem Master Cylinders and Installation Kits

The Mopar tandem M/C is the industry "standard," and available in cast iron or aluminum. Our 5-piece Master Cylinder Rod Kit facilitates installation (components listed above).

52490050 7/8" Tandem Mopar Mstr Cyl \$120.00
52490080 Mstr Cyl (Cast Iron) w/1" Bore 110.00
52490090 Mstr Cyl (Cast Iron) w/1-1/8" Bore 110.00
52496500 Master Cylinder Rod Kit 65.00
26048940 1-1/16" Aluminum w/Pushrod 135.00

Roll Bar & Cage Kits

You will find that Morrison roll bar and cage kits are the class of the industry. Easy installation is assured for two important reasons. The bars and cages are computer-designed for the specific applications using contemporary CAD technology, while the tubing is precision mandrel-formed on Morrison's sophisticated bending equipment. Instructions are furnished with each kit. Final fitting is necessary.

Because each kit is custom made for the application it must be prepaid. All bars and cages are shipped via motor carrier.



**8-Point
Roll Cage Kit
\$300**



**8-Point
Roll Bar Kit
\$220**

**Meets NHRA & IHRA
Safety Requirements**

8-Point Roll Cage Kit

For faster race cars our CAD-engineered 8-point cage is the answer. It comes standard with precision mandrel-bent 1-5/8"x.134" wall mild steel tubing (sure to pass "sonic" testing) and is also available in 4130 chrome moly tubing (1-5/8"x.083") for those applications where weight considerations are of primary importance.

20206000 8-Point Roll Cage.....	\$300.00
20206500 8-Pt. Roll Cage Constructed Out of 4130 Chrome Moly.....	600.00

8-Point Roll Bar Kit

Our 8-point roll bar and cage kits are specifically designed to strengthen unibody cars by reducing unwanted chassis flex. This has an added benefit in enhancing performance through improved traction and down-track stability. Substantial driver protection is also afforded with these fitted assemblies. The roll bar is made of 1-3/4"x.134" steel tubing. Please specify make, model, and year of car when ordering.

20203000 8-Point Roll Bar.....	\$220.00
20203500 8-Point Roll Bar Constructed Out of 4130 Chrome Moly.....	440.00



Custom Round & Rectangular Tube Bending

One of the things we do best at Art Morrison Enterprises is bend tubing. Our shop is equipped with computer-controlled equipment that can accurately form tubing up to 2"x4" in size with the quality work that comes from using special mandrels. Our engineering staff can transform your ideas into working drawings and AME's production team can bring them into reality. Through extensive experience we know what can be done with various size round and rectangular tube and can deliver what you need. Please call for custom quotes.

ROLL CAGE TECH TIP:

Tube Notching

You may have heard the old adage, "measure once, then measure again before cutting." This certainly applies to roll cage/bar assembly, where tube notching plays a vital role in ensuring that everything fits! See page 65 for a nifty tube notcher.





10-Point Roll Cage Kit
As Shown **\$335**

10-Point Roll Cage Kit

The ultimate in stiffness, strength, triangulation, safety, and performance. Each kit is made from 1-5/8"x.134" steel tubing or 4130 chrome moly in the lightest configuration possible without sacrificing the system's strength or protection. Added front and rear struts provide the rigidity needed to realize the benefits of fine chassis tuning, a definite plus for the serious-minded racer. Cages include dash bar and driver's side rocker bar. Cages

ordered by make, model and year of vehicle. Designed for the do-it-yourself home builder. Get installation details in our "Fast Track" video.

Please note that while Morrison lists this as a 10-point cage, to reflect the true number of chassis contact points, other manufacturers call this a "12-point" cage, adding in the side bars (which are included in the Morrison kit) to their count. Compare "apples to apples."

20209000 Mild Steel Roll Cage Kit.....\$335.00
20209500 4130 Chrome Moly Roll Cage Kit 670.00



Roll Bar Padding

Get required protection with high density padding. We have "offset" style round padding in 3' lengths.

20306901 Blk Roll Bar Padding, 3' Lngth \$10.00



#20240000

Swing-Out Side Bar Kit

This handy conversion kit enables you to more easily get in and out of a race car. Use with Morrison roll cage kit.

20240000 Swing-Out Side Bar Kit \$65.00



4-Point Roll Bar Kit \$165

4-Point Roll Bar Kit

The Morrison 4-point roll bar is made from 1-3/4"x.134" steel tubing and is designed for weld-in installation. Can be bent to retain stock rear seat, if specified. Please specify make/model/year, and rear seat use when ordering. This particular configuration is not NHRA "legal" (8-point bar required).

20200000 4-Point Roll Bar..... \$165.00
20205000 4-Point Roll Bar 4130
Chrome Moly 310.00
20211200 Retain Rear Seat Bars (Mild Steel) ... 45.00

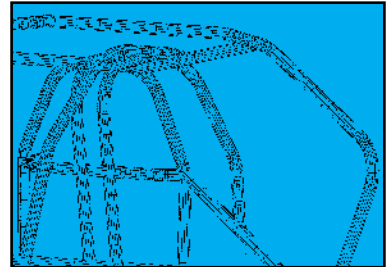

Roll Bar & Roll Cage Conversions and Related Accessories

Morrison has everything you need in the way of roll bar and roll cage accessories to upgrade or improve your present system in accordance with the latest racing association rule requirements. Call for details on any recommended updates to your particular chassis. Get optimum safety and convenience with Morrison roll cage accessories. Swing-out side bar kit contains brackets and all required hardware.

	Mild	4130	
20210050	8Pt Bar to 8Pt		
	Cage Conversion.....	\$145.00n/a
20210000	8 to 10-Pt. Cnvrn.	180.00n/a
	Retain Rear Seat Bars.....	45.00	.. \$80.00
	Rear X-Brace Kit.....	45.00	.. 100.00
	Door X-Brace Kit.....	45.00	.. 100.00
20250000	Flat Roll Bar Gussets		
	(Pkg.10).....	15.00n/a
30321180	F/C Cage Conversion Kit	230.00	
30321190	F/C Cage Conversion		
	Kit - 4130.....	420.00	

MORRISON

56



800-929-7188 • fax: 253-922-8847 • www.artmorrison.com



Anti-Roll Bar Assembly

This adjustable torsion bar assembly will help eliminate ET-robbing body roll. Bar exerts pressure on the rear end housing to prevent roll.

12120800 Anti-Roll Bar \$270.00



**NOW AVAILABLE
IN 3 SIZES!**

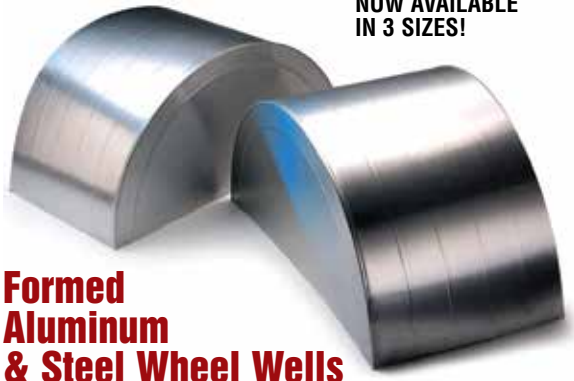

Formed Aluminum & Steel Wheel Wells

Morrison makes it easy to "tub" any vehicle with these premium grade formed wheel wells. You can choose between .032" aluminum or 22-gauge steel, as well as three sizes: 32, 38 and 40 inches in diameter. The panels fasten together with "Pittsburgh" interlocking seams for both ease of assembly and an excellent seal. You don't want smoke pouring into the driver's compartment during a burn-out!

The top panels feature four rolled beads and the side panel comes with a circular bead to provide extra rigidity and a finishing touch. The kit is shipped flat to reduce the chance of freight damage. To make the assembly process easier, invest in a set of Cleco pliers & fasteners. See page 65 for details.

Also available are 8" tub extensions, which can be employed for "mini-tub" use.

ALUMINUM

67670000 Alum. Wheel Wells 38"x22" \$125.00
 67670200 Alum. Wheel Wells 32"x22" 125.00
 67670400 Alum. Wheel Wells 40"x23" 160.00

STEEL

67676000 Steel Wheel Wells 38"x22" 125.00
 67676200 Steel Wheel Wells 32"x22" 125.00
 67676400 Steel Wheel Wells 40"x23" 160.00
 Tub Extension (8") Pair 30.00

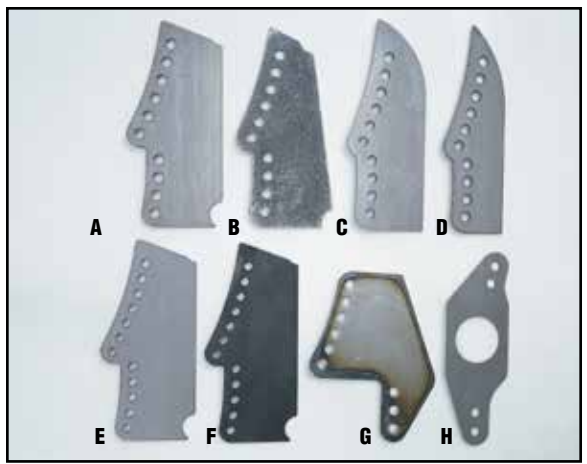

4-Link Suspension Brackets

Most every imaginable 4-link setup can be fabricated using these convenient suspension brackets from Art Morrison Ent.

14852670 (A) Super Car Round Tube (4) \$70.00
 14852671 (A) Super Car Round Tube 4130 (4) 140.00
 14852680 (B) Roadster (4) 70.00
 14852610 (C) 2"x3" Standard (4) 70.00
 14852620 (D) 2"x4" Standard (4) 70.00
 14852672 (E) Super Car Pro Link 1/2" Hole (4) 70.00
 14852673 (F) Super Car Pro Link 1/2" Hole 4130 (4) 140.00
 14852510 (G) Unequal Standard (4) 70.00
 14852410 (H) Housing Mount (4) 70.00



Dzus Fittings

AME carries a wide assortment of ever-popular Dzus "buttons" and companion plates. They are unbeatable when it comes to securing body panels, etc., that are routinely removed and re-installed. A handy wrench is available that is designed specifically for removing/installing Dzus buttons.

90857000 (A) Standard Button Flat Top \$2.00
 90857100 (B) Standard Plate 90
 90857200 (C) Standard Spring 90
 90857300 (D) Small Head .500" Self Eject 3.50
 90857400 (E) Small Head .550" Self Eject 3.50
 90857500 (F) Plate for Self Eject 90
 90857600 (G) Spring Self Eject 90
 90857700 (H) 90 Mounting Plate 3.00
 90858000 (I) Dzus Wrench 7.00
 90858100 (J) .500" Butterfly Button 3.50
 90858200 (K) .550" Butterfly Button 3.50
 90858300 (L) Large Head .500" Self Eject 4.00
 90858400 (M) Large Head .550" Self Eject 4.00



MORRISON

PERFORMANCE
AM
 QUALITY

57

800-929-7188 • fax: 253-922-8847 • www.artmorrison.com



Velocity Stacks

Morrison's contoured aluminum velocity stacks enhance air flow to the carburetor. For standard 4150-type 4-barrels or 4500 series.

64640000 Standard 4150 Velocity Stack \$30.00
 64644500 Dominator 4500 Velocity Stack 35.00



Power Steering Filter

Inline filter removes any particles in fluid that may contaminate the pressure relief valve, causing it to stick. This filter is perfect for pumps that have an integrated tank.

86835194 Power Steering Filter \$20.00



Parachute Release Kit

Designed to provide a sure, positive release of the drag chute. Kit includes a machined billet aluminum handle, mounting tab and all required cable attachments. Compact unit is perfect for use in a "door car" or dragster.

58685211 Parachute Release Kit \$45.00



Power Steering Filter and Reservoir

This power steering reservoir is perfect for those who are looking for more fluid volume and a filter. Filter prevents contamination and has an (included) easy spin on filter. Mounting bracket also included.

86835195 Power Steering Filter and Reservoir . \$280.00



Morse Cables & Acc.

Genuine Morse cables are available in 3' to 20' lengths in 1' increments, along with required mounting accessories; a quick release clamp for easy cable removal, a cable clamp and shim for more permanent mounting system, and a quick release ball joint featuring a 3/16" stud fitted quick-release ball. Morse cables from \$50.00.

(A) Quick Release Clamp \$15.00
 (B) Cable Clamp & Shim 5.00
 (C) Quick Release Ball Joint 10.00

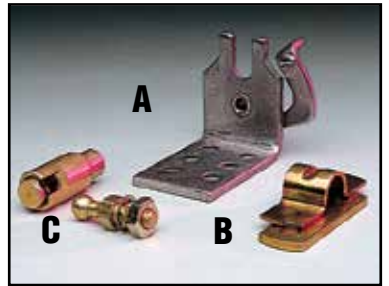

Morrison Rack & Pinion Dyno

We've long used our in-house Shock Dyno to test and evaluate various shock absorbers. Now we can do the same thing with steering racks. This AME creation will enable us to "fine tune" a chassis and match driver steering input with how everything responds to it. Our goal is to provide a synergy between driver input and chassis response.



MORRISON

58



800-929-7188 • fax: 253-922-8847 • www.artmorrison.com

Choice Of Front & Rear Steer Rack & Pinion Steering Boxes

To provide precise steering control Morrison offers a choice of Pinto, DSE, Flaming River, Maval and Dodge Omni rack & pinion setups. Both the popular 1971-72 Pinto and the DSE & Flaming River units are used for "front steer" (mounted in front of the spindles) applications. The Omni is ideally suited for "rear steer" type installations. These are all high performance aftermarket products.

86835129 Flaming River Rack (A).....	\$310.00
86835135 Opel Power Rack (B).....	\$25.00
86805231 Maval Power Rack (C).....	\$395.00
86835090 DSE Power Rack 20:1 (D).....	\$565.00
86854200 Pinto Rack & Pinion.....	\$245.00
30341600 Omni Rack & Pinion.....	\$360.00



NOTE:
Max pump pressure to be used is 1100# PSI

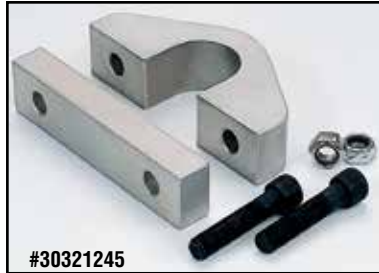

Billet Rack Mount

These precision machined clamps are just what you need to install a Pinto or Omni rack in most applications. Made of billet alloy. **\$50.00**



Steering U-Joints

Engineered for use in race car and street rod steering systems, heavy-duty Borgeson needle bearing U-joints are the optimum way to link multi-angle shafts. Needle bearings provide for smoother operation while reducing backlash.

Also available are standard U-joints with female bore on each end or one bore and one splined end with set screw bore locks. Available for all popular splined steering shafts. Priced from **\$60.00**.



Reservoir Tank

Here's a nifty way to store power steering fluid in your vehicle. All-aluminum Tank, cap, fittings all for **\$130.00**.



Opel Power Rack & Pinion Mount

Designed to securely mount the Opel rack & pinion to the crossmember. The unique feature of this mount is that it allows the builder to "rotate" the pinion to allow greater clearance for headers, accessories, lines, etc. **\$250.00**



Aluminum Bushing Kit

Perfect for when optimum steering accuracy is desired, these aluminum bushings eliminate the flex found in poly rack & pinion bushings. **\$45.00**.



Power Steering Cooler

This clever dual-purpose device serves to add to the capacity of your system while also providing important fluid cooling. The aluminum fins help dissipate heat, and also add a stylish touch that will enhance most any vehicle. Cooler fluid temperature contributes to improving the performance of any power steering system and also serves to increase fluid life. **\$65.00**



Woodward Racks now available



Double U-Joints

Designed especially for use in applications where the steering shaft intersect angle is very severe, these special "double" U-joints will work effectively at angles up to 60°. They are available for a variety of popular applications and priced from **\$165.00**.



Rack Fitting Kit

Contains pressure and return fittings that convert rack to -6AN. 86835155 Kit.....**\$40.00**



Steering Shaft Kits & Components

Art Morrison Ent. has developed an expertise in steering, and can easily configure a complete setup for your particular street machine, rod or race car. Morrison stocks a wide assortment of Borgeson quality components, and manufactures a number of specialized steering components. Call toll-free for details and design assistance.

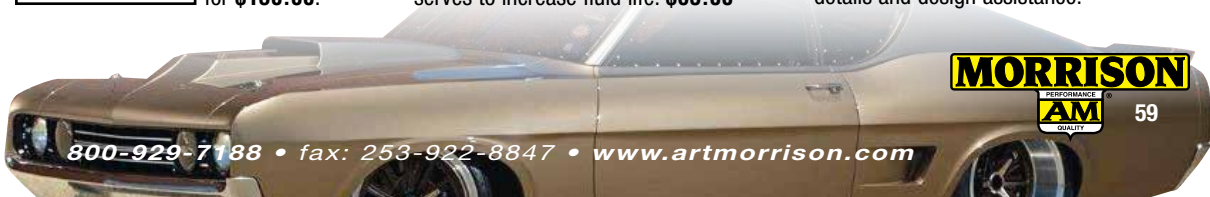

Motor Plates & Mid-Mounts



NOTE: All 1-Piece Plates Are Approximately 15"x30"



Steel Engine Mid Mounts

The perfect compliment to any motor plate fitted application, these steel mounts are installed between the engine and bellhousing and extend to the frame rails. They measure 14"x30" to fit a variety of chassis, .100" thick.

- 19195000 Chevy Mid Mount\$55.00
- 19195500 Ford 351M/400/429/460 Mid Mount.....55.00
- 19195600 Ford 289/302/351C & W (all 6-bolt blocks) Mid Mount.....55.00
- 19195900 Chrysler 273/318/340/360 SB Mid Mount.....55.00
- 19196000 Chrysler BB Mid Mount.....55.00



#19195100 Chevy **\$165**

#19196100 Big Mopar

Aluminum Mid Mounts

1/4" aluminum plates (6061-T6 alloy) complete with crank, starter and bellhousing holes. Trim to fit your chassis and you're in business. 24"x24" **\$165.00**

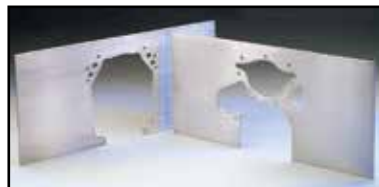

One and Two-Piece Aluminum Motor Plates

Morrison front motor plates provide for a convenient mounting system to install engines in about any chassis combination. Each motor plate is precision machined from 1/4" thick, 6061-T6 aluminum plate for a perfect fit. Your choice of lightweight 2-piece setups or stronger 1-piece plates. Available for most popular Chevy, Ford and Chrysler applications.

- 19191000 2-Piece Chevy S.B. Motor Plate.....\$165.00
- 19192000 2-Piece Chevy B.B. Motor Plate165.00
- 19193000 1-Piece Chevy S.B. Motor Plate.....165.00
- 19193100 1-Piece Chevy B.B. Motor Plate165.00
- 19193300 Chrysler Big Block Motor Plate.....165.00
- 19193400 Ford 429/460 Plate.....165.00
- 19193500 Ford 289/302/351W Motor Plate.....165.00
- 19193600 1-Piece 273/318, '67 & Later 340/360 S.B. Mopar.....165.00
- 19193700 Ford 351C Motor Plate.....165.00



Universal Motor Plate Mounting Kit

Kit contains a pair of strut tubes, to which the supplied mounting tabs are welded in the appropriate position. The required hardware is also included.

- 19190100 With Mild Steel Strut Tubes \$60.00
- 19190120 With Chrome Moly Strut Tubes 75.00

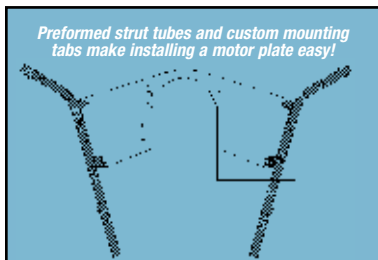

Preformed strut tubes and custom mounting tabs make installing a motor plate easy!

Engine Torque Limiter

The amount of torque movement generated by an engine at launch has a very pronounced effect on the way a race car hooks up. To help control this force Morrison offers a handy Engine Torque Limiter kit. It contains all the necessary components to fabricate an adjustable link between the engine and chassis, including mounting tabs, bar, threaded weld ends, rod ends, and all required hardware. Everything you need is in one convenient kit.

- 19197000 Engine Torque Limiter\$55.00



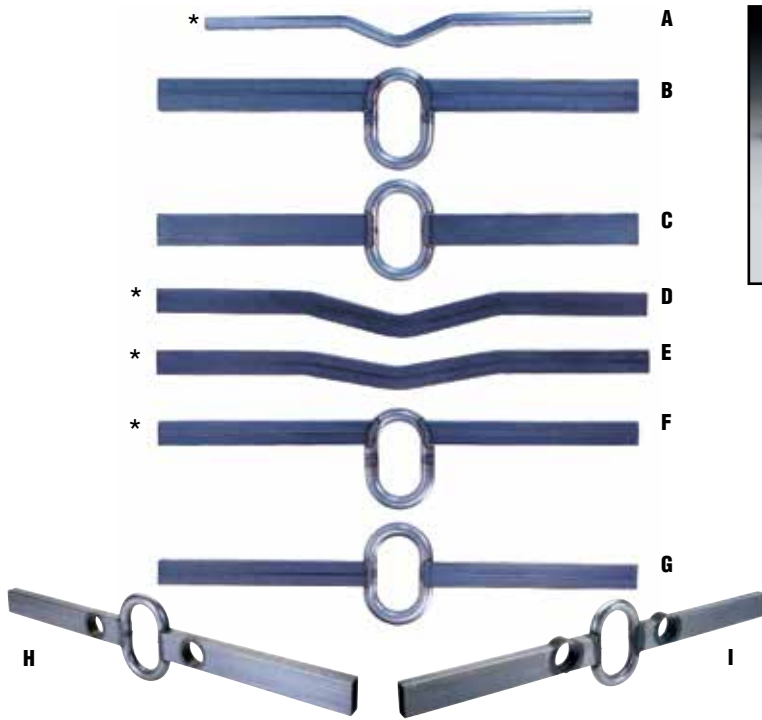

* Also available with plates and hardware

Rear Crossmembers & Driveshaft Loop Combos

Morrison offers you a wide selection of crossmembers for ladder bar installations, as well as crossmembers with built-in tubular "donuts" that serve as an effective driveshaft loop.

11852010 (A) Ladder Bar Crossmember	\$40.00
33330132 (B) 2"x4" Crossmember with Offset Donut	245.00
33330131 (C) 2"x4" Crossmember with Center Donut	245.00
11852012 (D) 2"x3" Ladder Bar Crossmember with a 3" Drop	90.00
11852013 (E) 2"x3" Ladder Bar Crossmember with a 2" Drop	90.00
33330122 (F) 2"x3" Crossmember with Offset Donut	240.00
33330121 (G) 2"x3" Crossmember with Center Donut	240.00
33330140 (H) 2"x4" Crossmember with Center Donut with Exhaust 2-1/2"	340.00
33330142 (I) 2"x4" Crossmember with Center Donut with Exhaust 3"	405.00
33330133 2"x4" Crossmember with Donut Unwelded (Not Pictured)	160.00
33330148 2"x6" Crossmember with Donut Exhaust 3" (Not Pictured)	490.00



Tube-Type Driveshaft Loop

All the straight tubing used to fabricate just about anything on a race car or street machine is available in pre-cut lengths shipped via UPS. For your convenience, 1-5/8" and 1-3/4" O.D. tubing can be obtained with one end pre-notched. Add \$5.00 per tube. All tubing sold in foot

increments. Call for shipping prices. 5' min. per size, cutting charges may apply.

Mild Steel Tubing

99911505 1.000"x.120" Wall (Per Ft.)	\$3.50
99911510 1.250"x.120" Wall (Per Ft.)	3.50
99912000 1.500"x.120" Wall (Per Ft.)	4.50
99912520 1.625"x.134" Wall (Per Ft.)	6.00
99912900 1.750"x.134" Wall (Per Ft.)	6.00

D.O.M. Tubing

99910000 .750"x.156" Wall (Per Ft.)	6.00
99910500 .875"x.156" Wall (Per Ft.)	6.00
99911000 1.00"x.156" Wall (Per Ft.)	6.00

Aluminum Tubing

99915340 1.625"x.058" Wall (Per Ft.)	8.00
--	------

4130 Chrome Moly Tubing

99900010 .375"x.058" Wall (Per Ft.)	6.00
99901700 .750"x.058" Wall (Per Ft.)	6.00
99902200 .875"x.058" Wall (Per Ft.)	6.00
99902700 1.000"x.058" Wall (Per Ft.)	7.00
99903000 1.125"x.058" Wall (Per Ft.)	7.00
99903510 1.250"x.058" Wall (Per Ft.)	8.00
99905000 1.500"x.065" Wall (Per Ft.)	8.00
99906500 1.625"x.083" Wall (Per Ft.)	10.00

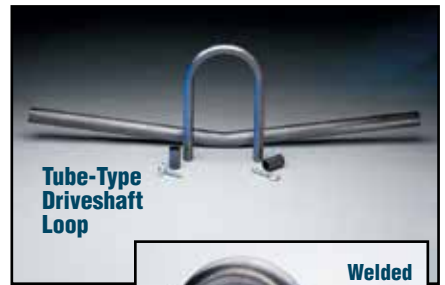

Tube-Type Driveshaft Loop



Welded Tubular Loop

Tubular 1/2 Loop

Driveshaft Loops

Complete your chassis package with one of our driveshaft safety hoops. They are available in all popular configurations. Required by many racing organizations.

33330120 Welded Tubular Oval Loop	\$75.00
33330125 Tubular 1/2 Loop	35.00
34340000 Tube Type Driveshaft Loop	55.00
34341000 Upper Tube Driveshaft Loop	30.00
34350000 Flat Strap Driveshaft Loop	50.00

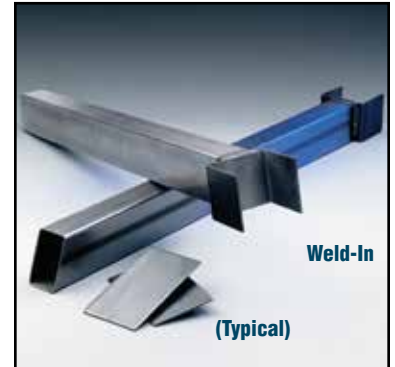

Weld-In

(Typical)

Frame Connectors

One of the most important chassis modifications you can do to a unibody car is to connect the front and rear subframes. These connectors can be used to reinforce the stock chassis members, or in conjunction with a front or rear clip (or both).

31317000 '67-69 Camaro	\$80.00
31317100 '70-81 Camaro	80.00
31317200 '62-67 Chevy II	80.00
31317300 '68-79 Nova	80.00
31317400 '64-73 Mustang	80.00
31317500 '64-76 Mopar A-Body	80.00
31317600 '62-75 Mopar B-Body	80.00
31317700 '70-74 Mopar E-Body	80.00



Mounts



Chevy Motor Mount Crossmember

Morrison's new 32" "universal" crossmember represents the easy way to install a small block or big block Chevrolet V8 engine in a wide variety of chassis. Trim the crossmember to fit between the frame rails and weld away! You can mount the engine solidly, or use the mounts below for a quieter, smoother installation primarily for street use.

- 19190200 Universal Chevrolet Motor Mount Crossmember \$80.00
 19190250 Chevrolet Engine Mount - Stock 50.00

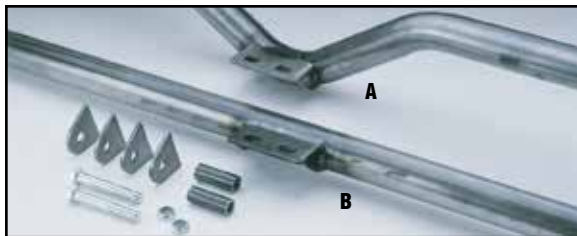

DeLuxe Transmission Crossmember

Designed for use with 2"x3" and 2"x4" rectangular tube chassis. The pad fits both Powerglide and Turbo-Hydro transmissions. It is installed by trimming the 42" crossmember to fit between your rails, welding the tabs to the frame per desired transmission height, and bolting the unit to the frame with the supplied hardware. Overall length 42".

- 36365700 (A) / 36365701 (B) DeLuxe Transmission Crossmember \$80.00
 36365710 OEM Transmission Mount 15.00
 36365800 Energy Suspension Transmission Mount 40.00



Transmission Crossmember With Clearance For Exhaust

This unique "Double Hump" crossmember has been designed to provide secure mounting for most popular transmissions while allowing clearance for the exhaust system. Can be used with either 2"x3" and 2"x4" rectangular tube chassis, and installed to facilitate quick removal. Some trimming of the crossmember required. Overall length 57".

- 36365560 Transmission Crossmember \$80.00



Quick Release Trans Mounts

Designed to facilitate securely mounting a transmission while also providing quick removal features for on-track efficiency. The crossmember style unit will fit Chevrolet Powerglide, GM Turbo-Hydro 350 and Turbo-Hydro 400, plus the Borg-Warner T-10 transmissions. It comes with a saddle-equipped crossmember plus mounting tabs and hardware. Please note that some trimming of the crossmember is required. Overall length 42".

- 36365500 Quick-Release Transmission Mount \$60.00



Energy Suspension Engine Mounts

Replace those nasty, rotting rubber engine mounts on your Chevy with these high performance polyurethane-padded units from Energy Suspension. They will improve handling and acceleration through reducing movement. Kit includes all required fasteners.

- 19190260 Energy Suspension Engine Mounts ... \$100.00



LS Engine Mount Kit

We've developed a highly effective mounting package for LS-series engines that incorporates Energy Suspension polyurethane bushings, and adapter plate with a positive stop, and OEM-style Chevy mounts.

- 32555740 LS Engine Mounts (Polyurethane) ... \$240.00
 32555745 LS Engine Mounts (Rubber) \$175.00



Chassis Stiffening Frame Gussets

These handy 2"x4"x.120" steel gussets are perfect for strengthening rectangular tube chassis at a number of key points. Stiffening the chassis will improve acceleration, handling and ride characteristics. They are cut on a 45° angle. Sold individually.

- 32344000 2 x 4 Gussets (Each) \$10.00

MORRISON

62



800-929-7188 • fax: 253-922-8847 • www.artmorrison.com





Spherical Rod Ends

These commercial grade rod ends are ideal for linkages and other light-duty applications, and they can also be used on the bottom bars of a 4-link suspension when budget is an issue. Check the potential forces to be exerted when deciding between commercial grade or heavy-duty 4130 units. For example, the radial static load of rod #89890700 is 13,831 lbs., compared to triple that for a chrome moly unit. All spherical rod ends are supplied with jam nuts.

89890300 3/8" Right Hand.....	\$5.00
89890310 3/8" Left Hand.....	5.00
89890400 7/16" Right Hand.....	6.00
89890410 7/16" Left Hand.....	6.00
89890500 1/2" Right Hand.....	8.00
89890510 1/2" Left Hand.....	8.00
89890600 5/8" Right Hand.....	12.00
89890610 5/8" Left Hand.....	12.00
89890700 3/4" Right Hand.....	15.00
89890710 3/4" Left Hand.....	15.00
89891800 5/8"x3/4" Right Hand.....	25.00
89891810 5/8"x3/4" Left Hand.....	25.00



4140 Specialty Rod End

For those extreme-duty applications, we offer a specialty rod end. The solid rod end is most often used on rear susp. ladder bars. Sold individually.

89892700 5/8"x3/4" S-D Solid R.H. Rod End Heat-Treated 4140	\$35.00
---	---------

**Anti-seize should be used in all Rod End installations*

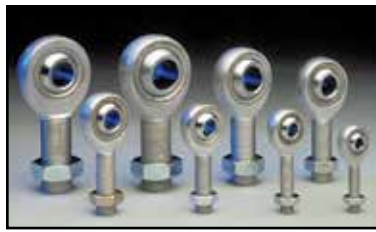

4130 Rod Ends

Our 4130 rod ends are designed to provide maximum strength for all high-load suspension applications. Ideal for top rods of 4-links. Radial static load on #89892600 is 28,081 lbs. For the most severe applications, our part number #89892900 and #89892910 ends are special heavy-duty models and positively the strongest of all 4130 rods. They are rated at 40,572 lbs. radial static load. Jam nuts included.

89892200 3/8" Right Hand.....	\$16.00
89892210 3/8" Left Hand.....	16.00
89892300 7/16" Right Hand.....	20.00
89892310 7/16" Left Hand.....	20.00
89892400 1/2" Right Hand.....	25.00
89892410 1/2" Left Hand.....	25.00
89892500 5/8" Right Hand.....	35.00
89892510 5/8" Left Hand.....	35.00
89892600 3/4" Right Hand.....	45.00
89892610 3/4" Left Hand.....	45.00
89892800 1/2"x5/8" R.H. H-D 4130 R/E.....	30.00
89892810 1/2"x5/8" L.H. H-D 4130 R/E.....	30.00
89892900 5/8"x3/4" R.H. H-D 4130.....	45.00
89892910 5/8"x3/4" L.H. H-D 4130.....	45.00

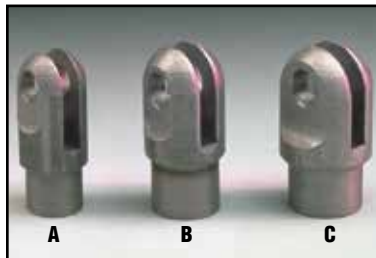

Weld Clevis

Attach tubing to chassis tabs, etc. with our clevis fittings. Just slip clevis joint into end of a tube and weld in place. The functional simplicity of the clevis works well in many other applications. Available to fit the most popular tubing sizes. Sold individually.

82893000 (A) Weld Clevis 3/16" Slot, 5/16" Hole, 3/4" O.D. Tube x .058" Wall.....	\$15.00
82893010 (B) Weld Clevis 3/16" Slot, 3/8" Hole, 7/8" O.D. Tube x .058" Wall.....	15.00
82893100 (C) Weld Clevis 3/16" Slot, 3/8" Hole, 1" O.D. Tube x .058" Wall.....	15.00
82893110 Weld Clevis 3/16" Slot, 3/8" Hole, 1.125" O.D. Tube x .058" Wall.....	18.00



Female Rod Ends

Female spherical rod ends can be used in most applications where rod end must thread onto a rod-type linkage. Uses include clutch and carb linkages. Complete with jam nuts.

89891300 3/8" Right Hand.....	\$5.00
89891310 3/8" Left Hand.....	5.00
89891400 7/16" Right Hand.....	6.00
89891410 7/16" Left Hand.....	6.00
89891500 1/2" Right Hand.....	8.00
89891510 1/2" Left Hand.....	8.00
89891600 5/8" Right Hand.....	12.00
89891610 5/8" Left Hand.....	12.00
89891700 3/4" Right Hand.....	15.00
89891710 3/4" Left Hand.....	15.00



Johnny Joint

Poly-Bushed Rod End

Johnny Joints & Stainless Steel Poly-Bushed Rod Ends

For street applications where ride comfort is a consideration, we offer Johnny Joints and polyurethane-bushed 17-4 alloy stainless steel ends. Ends are available with right hand and left hand threads featuring a 5/8" bore and 3/4" shank.

89890800 5/8"x3/4" Stainless Polyurethane Rod End (R.H.).....	\$30.00
89890810 5/8"x3/4" Stainless Polyurethane Rod End (L.H.).....	30.00
89890900 1/2"x5/8" Stainless Polyurethane Rod End (R.H. only).....	35.00
89893060 1" Johnny Joint Rod End (R.H.).....	55.00
89893061 1" Johnny Joint Rod End (L.H.).....	55.00
89893062 3/4" Johnny Joint Rod End (R.H.).....	55.00
89893069 3/4" Johnny Joint Rod End (L.H.).....	55.00

(Polished rod ends are available)

MORRISON



63

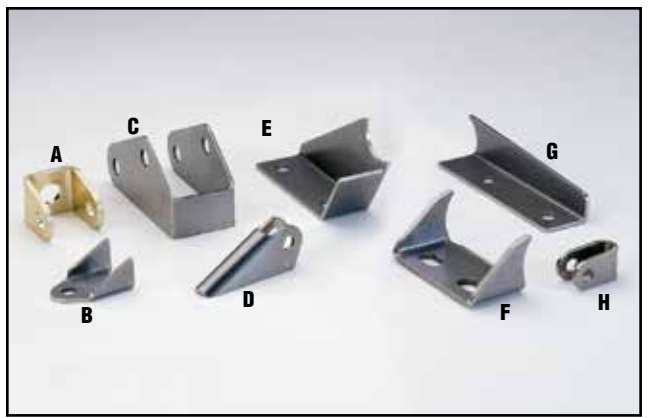
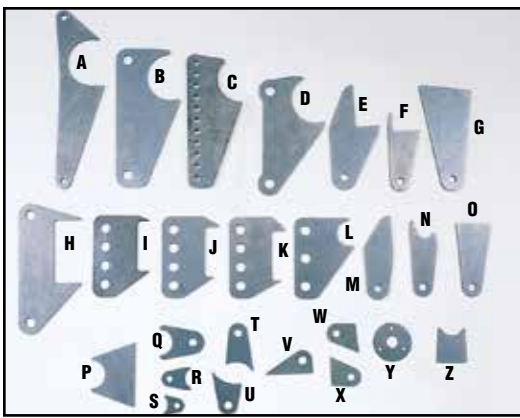

Special Chassis & Suspension Mounts, Brackets, Tabs And Flanges

Use these convenient, time-saving brackets, tabs and flanges for mounting assorted chassis and suspension components to your frame. Please note that some of them are designed for use on our SuperCar chassis, and others are more universal. All Morrison brackets, tabs and flanges are precision formed by conscientious craftsmen and ready to save you time and hassles in building your race car or street machine.

LEFT PHOTO

15159065 (A) Wheelie Bar Hsg Brkt.....	\$10.00
10851710 (B) Ladder Bar Hsg Brkt.....	10.00
18853100 (C) Coil-Over Hsg Brkt "Long".....	15.00
14150120 (D) 4/B Hsg mnt 5-1/2" Drop.....	10.00
86853500 (E) Lwr C/A Mnt 2x3 Subf.....	8.00
85855513 (F) Lwr C/A Brkt Strut Subf.....	7.00

12120330 (G) Panhard Bar Hsg Brkt.....	7.00
14150110 (H) 4/B frm mnt 1-7/16" Drop.....	10.00
11852210 (I) 2X3 L/B Xmbr Brkt Common.....	10.00
11852225 (J) 2X3 L/B Xmbr Brkt Ins Sol Med.....	10.00
11852220 (K) 2X3 L/B Xmbr Brkt Ins Poly Lwr.....	10.00
11852110 (L) L/B Xmbr Brkt 5/8".....	10.00
12120530 (M) Panhard Carrier Mnt Frm Brkt.....	6.00
86854980 (N) Pinto Fwd Strt Rod Brkt Long.....	5.00
85855320 (O) Long Strt Rod Brkt Strut X.....	5.00
AIR5247 (P) Air Rear Sprg Brkt UpR Rd.....	12.00

30321230 (Q) S/C Rnd Tube 1/2" Hole Brkt.....	4.00
91850100 (R) Universal Tab 3/8" Hole.....	5.00
91850000 (S) Seat Belt Tab.....	4.00
85855340 (T) Shrt Strut Rod Brkt Strut X.....	4.00
86854970 (U) Pinto Fwd Strt Rod Brkt Short.....	5.00
12852200 (V) D Link Weld Brkt.....	5.00
30321231 (W) 2X3 S/C Strut Brkt 1/2" Hole.....	6.00
12120329 (X) Panhard Bar Frm Brkt.....	3.00
51850700 (Y) Strg Wheel Mnt Flange.....	6.00
18841000 (Z) C/O UpR Mnt Gusset.....	3.00

TECH NOTE

To assist builders in using the proper threaded tube adapter for each particular tubing size we offer the following guideline:

Adapter to use	Tube specifications
3/4" adapter	1-1/8" O.D. Chrome Moly (.065-.058" wall)
5/8" adapter	1" O.D. Chrome Moly (.058" wall)
1/2" adapter	7/8" O.D. Chrome Moly (.049-.058" wall)
3/8" adapter	7/8" O.D. Chrome Moly (.049-.058" wall)
3/8" adapter	3/4" O.D. Chrome Moly (.049-.058" wall)
5/16" O.D. Chrome Moly (.049-.058" wall)	5/8" O.D. Chrome Moly (.049-.058" wall)

See available tube adapters selection below



Threaded Tube Adapters

Add a threaded fitting to the end of a tube with these tube adapters. Each size is available with either right or left hand threads. Sold individually.

81893200 (A) 5/16" TTA R.H.....	\$6.50
81893210 5/16" TTA L.H.....	6.50
81893300 (B) 3/8" TTA R.H.....	6.50
81893310 3/8" TTA L.H.....	6.50
81893400 (C) 7/16" TTA R.H.....	7.50
81893410 7/16" TTA L.H.....	7.50
81893500 (D) 1/2" TTA R.H.....	8.50
81893510 1/2" TTA L.H.....	8.50
81893600 (E) 5/8" TTA R.H.....	8.50
81893610 5/8" TTA L.H.....	8.50
81893700 (F) 3/4" TTA R.H. 1-1/8".....	9.00
81893710 3/4" TTA L.H. 1-1/8".....	9.00
81893800 3/4" TTA .095 4130 R.H. 1-1/4".....	13.00
81893810 3/4" TTA .095 4130 L.H. 1-1/4".....	13.00
81893900 3/4" TTA .095 4130 R.H. 1-3/8".....	13.00
81893910 3/4" TTA .095 4130 L.H. 1-3/8".....	13.00

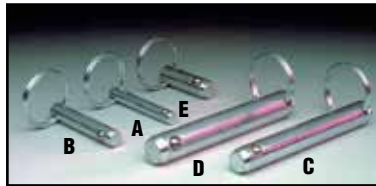

Quick Pins

Use these quick pins for easy removal and installation of wheelie bars, side bars, radiators, etc. All pins sold individually.

88894900 (A) 1/4"x1-1/4".....	\$2.00
88895000 (B) 5/16"x1-1/8".....	2.00
88895100 (C) 7/16"x2-1/2".....	4.00
88895200 (D) 1/2"x2-1/2".....	4.50
88895300 (E) 3/8"x5/8".....	3.00



Misalignment Bushings

Bushings allow full travel of spherical rod ends without binding. They also prevent dangerous rod end failure in steering and suspension applications. Gold cadmium plated bushings available in 3/8"-5/8" bore sizes. Sold individually.

74842800 (A) 3/8" Bore, .210" Tall.....	\$2.50
74842900 (B) 7/16" Bore, .300" Tall.....	2.50
74843200 (C) 1/2" Bore, .195" Tall.....	2.50
74843100 (D) 1/2" Bore, .300" Tall.....	2.50
74843500 (E) 5/8" Bore, .570" Tall.....	2.50

RIGHT PHOTO

12852210 (A) D Link Clevis Brkt 5/8".....	\$8.00
91850200 (B) Mtr Plate Tab.....	5.00
15159061 (C) P/S WB Formed Wheel Brkt.....	15.00
91850400 (D) Radius Rod Frm Brkt.....	12.00
86853800 (E) Pinto Rack Xmbr Mnt LH.....	8.00
36365002 (F) Trans Mnt Brkt Street.....	20.00
86853700 (G) Pinto Rack Xmbr Mnt RH.....	8.00
82850300 (H) Heim Jt Weld Clevis .375.....	9.00



Quick Release Pit Pins

These handy quick-releasing pins can be used in a number of ways on most any race car. Ideally suited for securing those parts that must be quickly removed as a part of between-round servicing. Five convenient sizes to choose from.

88895400 (C) 3/16"x1" Q/R Pin-Button Head.....	\$25.00
88895500 1/4"x1-1/2" Q/R Pin-T Handle.....	25.00
88895600 (B) 5/16"x1-1/2" Q/R Pin-T Handle.....	30.00
88895700 (A) 3/8"x2" Q/R Pin-T Handle.....	30.00
88895800 1/2"x2-1/2" Q/R Pin-T Handle.....	35.00



#17171700

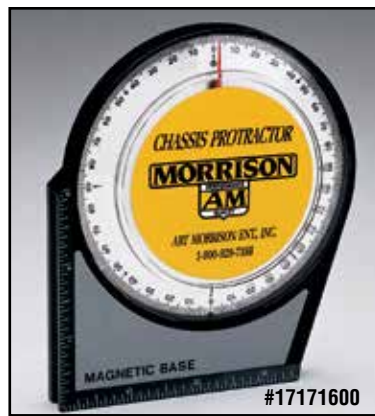

#17171600



Chassis Construction & Setup Protractors

These tools serve many valuable functions in setting up a race car or street machine. Use them for setting suspension geometry, engine position, chassis alignment, etc. The Electronic Digital Protractor has an accuracy of $\pm 0.1^\circ$ at level and plumb, and has a machined aluminum frame. Our economical analog protractor features a heavy-duty magnetic base, 4" diameter dial with a full 360° read-out in one degree increments and a magnetic base. The plumb bob makes it easy to square a race car. Includes 16' of string.

- | | | |
|--|---------------------------------|-------------------------|
| 17171700 Electronic Digital Protractor
(Uses 9v Battery)..... | 17171600 Analog Protractor..... | 17171800 Plumb Bob..... |
| \$200.00 | \$15.00 | 16.00 |



AME Ball Joint Tool

This handy little tool allows for easy replacement of AME's screw-in ball joints.

- | | |
|-------------------------------|---------|
| 86854510 Ball Joint Tool..... | \$40.00 |
|-------------------------------|---------|



Safety Wiring Tools

Safety wiring is used extensively in aircraft to prevent fasteners and key components from coming loose. Get the same kind of reliability in your Street Rod or race car. Everything you need is available with one call.

- | | |
|--|---------|
| 90863000 (A) 9" Safety Wire Pliers..... | \$30.00 |
| 90863002 (B) 6" Safety Wire Pliers..... | 25.00 |
| 90863004 (C) Nut Safety Block Drilling Jig..... | 40.00 |
| 90863006 (D) Bolt Safety Block Drilling Jig..... | 40.00 |
| E99D002 (E) Safety Wire .032..... | 25.00 |



Cleco Kits With Pliers

A must for installing sheet metal, wheel tubs, panels, etc. Great for test fitting and mock-ups. Every serious fabricator should have a set of Clecos in their tool box!

- | | |
|--|---------|
| 90861125 30 Pc. with Pliers - 1/8"..... | \$35.00 |
| 90861188 30 Pc. with Pliers - 3/16"..... | 35.00 |

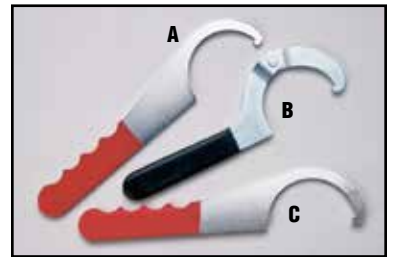
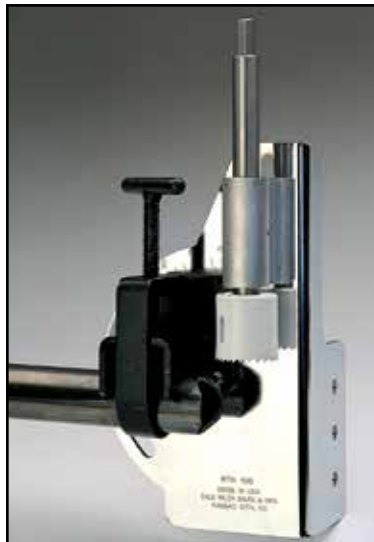

Spanner Wrenches

All-important tools for adjusting coil-over shocks and struts. They feature rubberized handles for non-slip convenience. A special adjustable spanner wrench fits virtually all applications.

- | | |
|---|---------|
| 17166400 (A) Spanner Wrench, Small..... | \$16.00 |
| 17166200 (B) Spanner Wrench, Adj..... | 30.00 |
| 17166300 (C) Spanner Wrench, Large..... | 16.00 |

Tubing Notcher

When installing a roll bar or cage it is important to obtain the optimum fit for all intersecting joints. This handy device uses hole saw blades to "fishmouth" the tubes, and can be powered by an ordinary 1/2" variable speed drill press (a maximum of 550 RPM is recommended). The fixture clamps to the tubing, and the cutting angle can be adjusted from 45° to 90° to handle virtually any required fit. This device economically delivers true professional results and saves time!

- | | |
|-------------------------------|----------|
| 17173000 Tubing Notcher..... | \$170.00 |
| 17173063 1-5/8" Hole Saw..... | 18.00 |
| 17173075 1-3/4" Hole Saw..... | 18.00 |



MORRISON

PERFORMANCE
AM
QUALITY

65

800-929-7188 • fax: 253-922-8847 • www.artmorrison.com

Apparel and Promotional Items

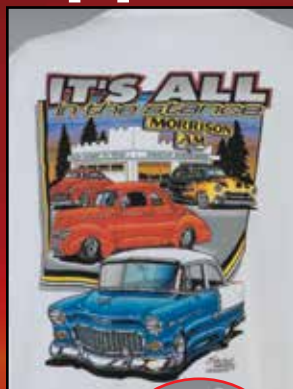

A
"It's The Stance"
Men's T



B
Standard Logo
Men's T



C
Flamed Black
Men's T



D
Flamed White
Men's T



E



F

G



H

I



J

PLEASE ORDER BY LETTER & SIZE

- A Men's white "Stance" T (sizes S,M,L,XL)\$15.00
- A Men's white "Stance" T (size XXL).....\$16.00
- A Men's white "Stance" T (size XXXL).....\$17.00
- B Men's white "Standard" T (sizes S,M,L,XL).....\$15.00
- B Men's white "Standard" T (size XXL)\$16.00
- B Men's white "Standard" T (size XXXL).....\$17.00
- C Men's black "Flamed" T (sizes S,M,L,XL).....\$17.00
- C Men's black "Flamed" T (size XXL)\$18.00
- C Men's black "Flamed" T (size XXXL).....\$19.00

- D Men's white "Flamed" T (sizes S,M,L,XL)\$15.00
- D Men's white "Flamed" T (size XXL).....\$16.00
- D Men's white "Flamed" T (size XXXL).....\$17.00
- E Ladies small flamed Logo T (sizes S,M,L,XL).....\$15.00
- F Black knit watch cap with logo.....\$10.00
- G Gray knit watch cap with logo.....\$10.00
- H Hat with logo\$25.00
- I Hat with logo.....\$25.00
- J Black GT Sport jacket (S-XL).....\$90.00
- J Black GT Sport jacket (XXL).....\$90.00

- J Black GT Sport jacket (XXXL).....\$100.00
- K Coddington '55 Chevy GT Sport Build Book...\$20.00
- L Morrison Super Gas '55 Chevy Build Book.....\$5.00
- M Morrison vinyl display banner\$20.00
- N Morrison GT-Sport banner.....\$20.00
- O Large Morrison\$5.00 per pair
- P Morrison Super Cars\$5.00 per pair
- Q Morrison Pro Truck\$5.00 per pair
- R Small Morrison logo\$3.00 per pair

log onto www.artmorrison.com for latest AME apparel

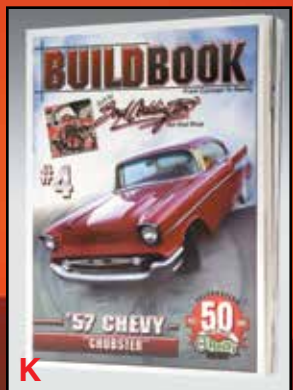

K

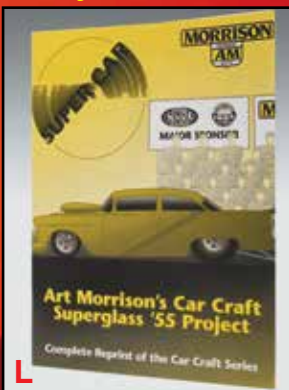

L



M



N



P



Q



R



Terms and Conditions

Payment

Art Morrison Enterprises, Inc. accepts cash, money order, cashiers check, personal checks (check verification) or orders charged to Visa, Master Card and American Express accounts. All custom-ordered components, or those shipped via motor freight, must be prepaid.

Shipping and Ordering

All shipments are F.O.B. Fife, Washington. All Motor Freight shipments must be prepaid with a credit card, money order, cashiers check, check or cash. Credit card purchases for first time purchasers must be shipped to the cardholder's address. This procedure is designed to protect you, the cardholder.

Foreign Shipments

Unless restricted by law, Art Morrison Enterprises will ship to foreign customers. Full purchase price (in U.S. currency) must accompany order. Name of desired freight carrier, and all required import/export documents must be included with order.

Damaged or Missing Product

Shipping damage should be noted with the carrier at the time of delivery and the claim process started in accordance with that company's procedures. Notify Art Morrison Enterprises, Inc., as soon as possible.

It is possible that shipments can be incomplete. **It is the customer's responsibility to inventory all shipments received and report any shortages to Art Morrison Enterprises, Inc., within 30 days of receipt of your order.**

Custom Items

Products custom-made to the specifications of the customer, such as frame rails, axles, etc. are non-returnable for reasons other than defects in materials or workmanship.

Prices

All prices are subject to change without notice. Art Morrison Enterprises is not responsible for typographical price errors in this catalog or our advertising.

METHODS OF PAYMENT

- | | |
|--|---|
| <input type="checkbox"/> VISA, M/C, DISC | <input type="checkbox"/> WIRE TRANSFER |
| <input type="checkbox"/> MONEY ORDER | <input type="checkbox"/> PERSONAL CHECK |
| <input type="checkbox"/> CERTIFIED CHECK | |

Returns

All returns of merchandise must include a Returned Goods Authorization Number (RGA#) prominently displayed on the return packaging. This RGA# can be obtained from your representative at Art Morrison Enterprises, Inc. All credits and refunds are subject to a 15% restocking charge and will only be made for goods that are unused, unaltered, undamaged (including rust) and ready for resale. Custom manufactured items are not subject to return for credit or refund. A copy of the original sales documentation must be included with the returned merchandise and include complete current contact information—name, address, phone, fax, e-mail, etc. Art Morrison Enterprises, Inc., will refuse any COD or collect shipments. **After 90 days, no credits or refunds will be allowed for any merchandise.**

Specifications

Non-critical specifications and plating are subject to change without notice.

Disclaimer

Seller disclaims any warranty, express or implied, with respect to the parts sold hereby as to merchantability, fitness for particular purpose, or any other matter.

Racing Association Rules

Because a number of products manufactured and/or sold by Art Morrison Enterprises are subject to approval by various race sanctioning organizations, the customer is responsible to verify that the items purchased comply with the rules they compete under. The "legality" of the vehicle is up to the builder.

Warning

Products manufactured by Art Morrison Enterprises, Inc. and/or contained in this catalog are designed for competition purposes. Accordingly, use of said products, or modification to or construction of a vehicle for those purposes may create dangerous conditions which could cause bodily injury, and the buyer hereby expressly assumes all risks associated with any such modifications.

VISIT OUR SHOWROOM

5216 7th Street E.
Fife, Washington
98424
Hours: Mon.-Fri. 7AM
- 5PM (Pacific)

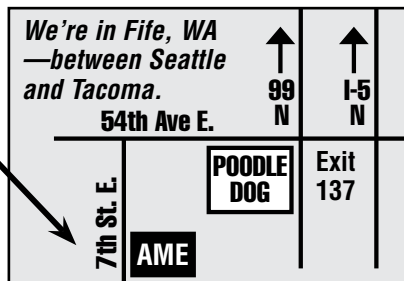



Art Morrison Enterprises, Inc.
5301 8th Street East, Fife, WA 98424

Phone: **800-929-7188**

Local: 253-922-7188

Internet: www.artmorrison.com

Fax: 253-922-8847

Office Hours: Monday through Friday
7 AM to 5 PM (Pacific)



More Important Tech Info For Do-It-Yourself Builders!



MORRISON



Morrison "How To" Technical Videos...

We've got a pair of highly informative videos that will be an asset to any do-it-yourself builder. The first is our famed "Fast Track" video, which covers step-by-step installation of a rear suspension clip, roll bar, subframe connectors, fuel cell and wheel tubs. Included are many handy tips that help you get professional results. Our second video covers installing a Morrison I.F.S. front end on a fat-fendered street rod. Our DVD includes both front and rear videos for \$25 (plus s/h).

