

SPEED
FOR
ALL

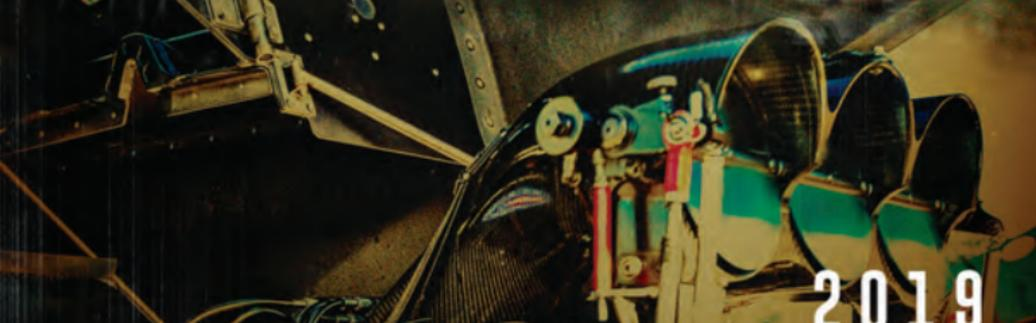

2019

RULEBOOK



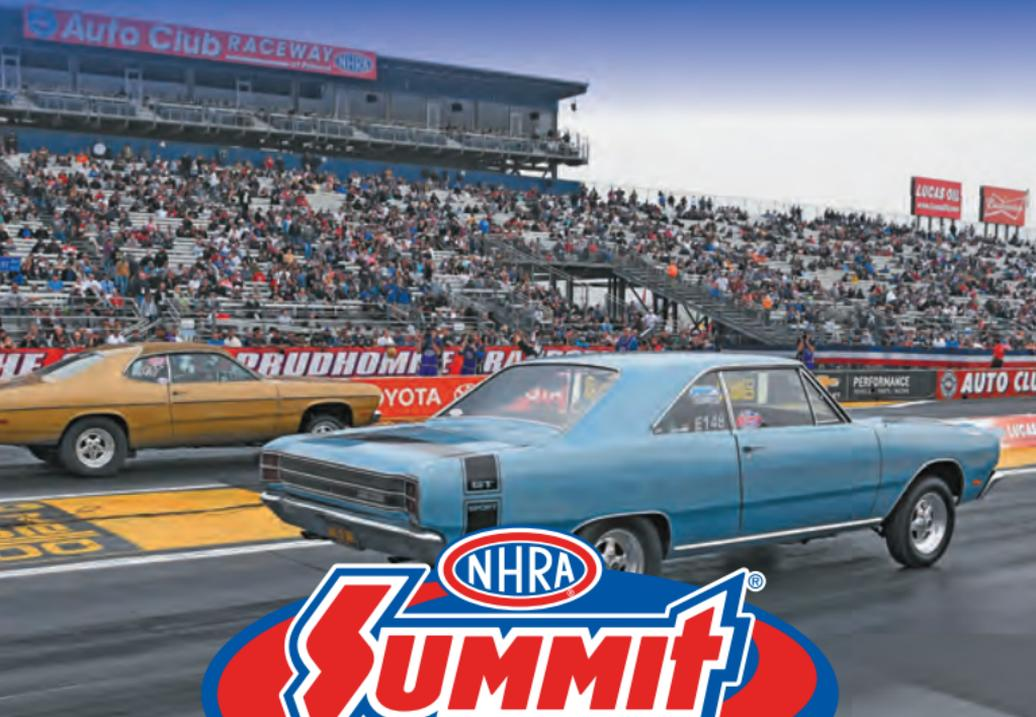

Winning Takes Work. Getting Parts is Easy.

Get the performance you want—and solid value for your hard-earned money—at Summit Racing Equipment. Call or visit us online today and see why we've been The World's Speed Shop® since 1968!

- *The largest inventory of performance and racing parts in the country*
- *Fast same-day shipping on orders for in-stock parts placed by 10 pm EST*
- *Guaranteed low prices every day*
- *Number One-rated customer service and technical support*



SummitRacing.com is Your Online Performance Shop!

- *Huge online catalog featuring millions of parts*
- *Savings Central—special offers, rebates, sales, clearance items, and more*
- *Track orders, ask tech questions, and much more!*
- *Shop anytime with the Summit Racing Mobile App*

1-800-230-3030
SummitRacing.com®

NATIONAL HOT ROD ASSOCIATION

In its 67th year, NHRA continues to offer an unequaled motorsports experience for racers, sponsors, and fans. Keys to the success



have been NHRA's focus on racer participation at all levels and providing venues to race with rules designed to provide fair competition and to enhance safety. One way that NHRA consistently achieves these important objectives is through the development of a Rulebook designed to provide guidance for NHRA activities, participants, and member tracks.

NHRA's wide variety of racing series accommodates racing at all levels of interest, a wide range of vehicles, and from age 5 on up.

The Top Fuel, Funny Car, Pro Stock, and Pro Stock Motorcycle classes share top billing in the sport's NHRA Mello Yello Drag Racing Series. The Mello Yello Series is a full season's tournament of major national events produced in prime market locations from coast to coast.

In addition, racing is conducted at the national, regional, and divisional level in the NHRA Lucas Oil Drag Racing Series, a schedule that includes a myriad of classes ranging from Top Alcohol Dragster to Super Street.

Supercharged or turbocharged, methanol-burning or nitrous-oxide-injected, gasoline-burning full-bodied cars compete in the 10-race E3 NHRA Pro Mod Drag Racing Series presented by J&A Service schedule showcased at 10 national events.

E.T. racing is based on the bracketing of elapsed-time performances in producing categories for handicap-start competition. Because of its open-ended rules, E.T. racing encourages participation by a wide variety of vehicle types, from street rods to muscle cars to the latest offerings from domestic and foreign automakers. The NHRA Summit Racing Series is the entry level for most first-time racers, and its grassroots nature offers an affordable welcome to newcomers and old-timers in the sport. More than 6,000 events are conducted annually at approximately 120 NHRA member tracks throughout the United States and Canada. About 80 percent of total entries at these events are E.T. racers. Also, NHRA Drags: Street Legal Style presented by AAA lets almost anyone take almost any street vehicle out to a local track for a thrilling taste of the strip.

In 2014, NHRA introduced the NHRA Jr. Street program for 13- to 16-year-olds. At participating NHRA member tracks, teenagers who have completed the licensing requirements can compete against one another in their approved vehicles.

The Summit Racing NHRA Jr. Drag Racing League for NHRA's youngest drivers is based on half-scale dragsters and a single-cylinder engine. The class is open to youth 5 to 17 and is conducted at most NHRA member tracks.

NHRA invites you to join the fun of organized drag racing at your nearest NHRA dragstrip as a member of NHRA, the world's largest auto racing organization.

NATIONAL HOT ROD
ASSOCIATION - A
member of ACCUS-FIA

COPYRIGHT © 2018 by the
National Hot Rod Association.
No part of this Rulebook may be
reproduced without the express
written permission of the National
Hot Rod Association.



TABLE OF CONTENTS

2019 NHRA Rulebook

	Section	Page
Introduction		i
NHRA Personnel		iii
NHRA Division Offices		iv
NHRA Jr. Street		xv
How to Use This Rulebook		xvii
General		
Administrative Procedures & Appeals	1	1
Race Procedures	2	1
Points and Related Programs	3	1
NHRA Summit Racing Series		
E.T. Handicap Racing	4	1
Super Pro, Pro, Sportsman (7.50 & slower)	4A	2
Advanced E.T. (6.00 to 7.49)	4B	9
E.T. Motorcycle (7.50 & slower)	4C	13
Advanced E.T. Motorcycle (6.00 to 7.49)	4D	16
E.T. Snowmobile (7.50 & slower)	4E	16
All-Terrain Vehicle (7.50 & slower)	4F	20
Electric-Powered Vehicle (7.50 & slower)	4G	22
Electric-Powered Motorcycle (7.50 & slower)	4H	24
Legend Cars	4I	24
Mickey Thompson Tires NHRA Top Fuel Harley		
Drag Racing Series	5	1
E3 Spark Plugs NHRA Pro Mod Drag Racing		
Series presented by J&A Service	6	1
Top Sportsman and Top Dragster presented by Racing RVs	7	1
NHRA Lucas Oil Drag Racing Series		
Super Street	8	1
Super Gas	9	1
Super Comp	10	1
Stock	11	1
Stock Cars	11A	1
Super Stock	12	1
Super Stock	12A	1
Super Stock/GT	12B	11
GT/Truck	12C	15
Modified Stock	12D	16
Modified Truck	12E	21
Modified	12F	24
Super Stock/MX	12G	28
Comp	13	1
Gas Dragster	13A	5
Econo Dragster	13B	10
Nostalgia Dragster	13C	14
Altered & Street Roadster	13D	16
Altered Truck	13E	26
Econo Altered	13F	31
Super Modified	13G	36
Pro Modified	13H	43
Top Alcohol Dragster	14	1
Top Alcohol Funny Car	15	1
NHRA Mello Yello Drag Racing Series		
Pro Stock Motorcycle	16	1
Pro Stock	17	1
Funny Car	18	1
Top Fuel Dragster	19	1
Exhibition Vehicles	20	1
General Regulations	21	1
Charts and Formulas	22	1

In the case of differences in interpretation regarding terms used in various translations of the rules and regulations of NHRA, the English text will control.

NATIONAL HOT ROD ASSOCIATION

2035 Financial Way, Glendora CA 91741 • 626-914-4761

Office hours: Monday through Friday, 8:30 a.m. to 5:30 p.m.

Founder Wally Parks (1913-2007)

Board of Directors

Dallas Gardner, Chair

Peter Clifford

Michael C. Cohen

Ed Desser

Glen Cromwell

Leadership Team

Chief Executive Officer	Peter Clifford
President	Glen Cromwell
Vice President and Chief Strategy Officer, Content and Technology	Ken Adelson
Vice President-Track Management & Operations	Kasey Coler
Vice President-Sales & Chief Development Officer	Brad Gerber
Vice President-Live Events and Field Marketing	Evan Jonat
Vice President-Human Resources	Marleen Gurrola
Vice President & General Counsel	Linda Louie
Vice President-Racing Administration	Josh Peterson
Vice President-Competition	Ned Walliser
Vice President-National Event Marketing	Kristen Wentzell
Vice President-Marketing & Communications	Jeffrey Young

Department Leaders

Technical Administration Executive	Glen Gray
Controller	Curt Winiecki
Editorial Director	Phil Burgess
Broadcasting Coordinating Producer	Steve Reintjes
Broadcasting Technology Executive	Mike Rokosa
Senior Director of Technology	Shervin Farivar
Senior Director of Public Relations & Communications	Jessica Hatcher
Senior Director of Safety & Emergency Services	Bob Lang
Senior Director of Corporate Marketing & Partnerships	Gary Raasch
Senior Director of Sales & Business Development	John Siragusa
Director of Broadcast Operations & Supervising Producer	Rob Hedrick
Director of Marketing & Client Services	Mario Hirose
Director of Multimedia Content & Contingency Program	David Kennedy
Director of Ticketing Operations	Seneca Manzo
Director of Advertising Sales	Jeff Morton
Director of Media Relations	Scott Smith
Director of Financial Planning & Analysis	Gina Van Vleck
Director of Engineering	Timothy White
Director of Technical Services	Jeff Conley
Safety, Event Planning and Compliance Officer	Mark Adams

Rulebook Staff

Editorial Director	Phil Burgess
Production Manager	Matthew Hurd
Art Director-Special Projects	Jeff Mellem
National Advertising Sales	Joni Elmslie
Senior Ad Services Rep	Maria G. Aguilar

DIVISION FIELD OFFICES

NORTHEAST DIVISION (1) OFFICE

Dave Mohn, Division Director, dmohn@nhra.com, 717-584-1200; fax, 717-390-3052

Ryck Campbell, Tech Director, rcampbell@nhra.com, 315-335-8295

Kyra Martin, Division Administrative Assistant, kmartin@nhra.com, 717-584-1205

2420 Gehman Lane, Suite 200, Lancaster, PA 17602

Monday and Thursday, 7-9 p.m. ET

Northeast Division: Connecticut, Delaware, District of Columbia, Maine, Maryland, Massachusetts, New Hampshire, New Jersey, New York, Pennsylvania, Rhode Island, Vermont, Virginia, and West Virginia; Maritime Provinces, Eastern Ontario, and Quebec, Canada

SOUTHEAST DIVISION (2) OFFICE

Rich Schaefer, Division Director, rschaefer@nhra.com, 352-374-9922; fax, 352-372-0418

Harry Ferrari, Tech Director, hferrari@nhra.com, 757-537-2763

Cody Savage, Division Services Coordinator

11223 N. County Road 225, Gainesville, FL 32609

Southeast Division: Alabama, Florida, Georgia, Mississippi, North Carolina, South Carolina, Tennessee, and Virginia; Puerto Rico and the Caribbean

NORTH CENTRAL DIVISION (3) OFFICE

William Tharpe, Division Director, wtharpe@nhra.com, 317-406-7740

Joe Lease, Tech Director, 844-468-7631

Kenny Lubanski, Division Services Coordinator, 317-969-7932

Neysa Jones, Division Administrative Assistant, 317-969-8890

PO Box 34300, Indianapolis, IN 46234; 317-969-8890; fax, 317-291-4220

Monday-Thursday, 8 a.m.-8 p.m. ET, Friday, 8 a.m.-3 p.m. ET

North Central Division: Illinois, Indiana, Kentucky, Michigan, Ohio, and Wisconsin; Western Ontario, Canada

SOUTH CENTRAL DIVISION (4) OFFICE

Trey Capps, Division Director, tcapps@nhra.com, 469-248-0014; fax, 469-248-0024

Technical Services 844-468-7631

TJ Bailey, Division Services Coordinator, 469-248-0014

12959 Jupiter Road, Suite 240, Dallas, TX 75238

Monday and Friday, 7-9 p.m. CT

South Central Division: Arkansas, Louisiana, Mississippi, New Mexico, Oklahoma, Tennessee, and Texas; Mexico

WEST CENTRAL DIVISION (5) OFFICE

Rob Park, Division Director, rpark@nhra.com, 816-795-8055; fax, 816-795-0515

Bob Blackwell, Tech Director/National Crew Chief, bblackwell@nhra.com, 816-795-8055

Travis Hilton, Division Services Coordinator, thilton@nhra.com, 816-795-8055

Sara Walker, Division Offices Services Administrator, swalker@nhra.com, 816-795-8055

3720 Arrowhead Ave., Suite 103, Independence, MO 64057

Monday-Thursday, 9 a.m.-5 p.m. CT, Friday, 9 a.m.-noon CT

West Central Division: Colorado, Illinois, Iowa, Kansas, Minnesota, Missouri, Nebraska, North Dakota, South Dakota, Wisconsin, and Wyoming; Manitoba, Canada

NORTHWEST DIVISION (6) OFFICE

Matt Levonas, Division Director, mlevonas@nhra.com, 253-446-6594; fax, 253-446-6683

Dave Schaffel, Tech Consultant, dschaffel@nhra.com, 306-374-3685; fax, 306-477-7707

Judy Richey, Division Administrative Assistant

8412 Myers Road E, Suite 305, Bonney Lake, WA 98391

Monday and Friday, 7-9 p.m. PT

Northwest Division: Alaska, Idaho, Montana, Oregon, and Washington; Alberta, British Columbia, and Saskatchewan, Canada

PACIFIC DIVISION (7) OFFICE

Mike Rice, Division Director, mrice@nhra.com, 626-914-4761, ext. 498; fax, 626-466-9089

Pat Cvengros, Tech Director, pcvengros@nhra.com, 626-250-2295

2035 Financial Way, Glendora, CA 91741

Monday-Thursday, 8 a.m.-5 p.m. PT, Friday, 8 a.m.-noon PT

Pacific Division: Arizona, California, Colorado, Hawaii, Nevada, New Mexico, and Utah; Mexico

National Technical Services Representatives

Monday-Thursday, 8 a.m.-8 p.m. ET; Friday, 8 a.m.-3 p.m. ET

For technical questions, call 844-468-7631 (841-HOTROD1)

Tech Services: email, TechDL@nhra.com

Membership Services: 800-308-6472; outside U.S., 626-250-2490; membership@nhra.com

NHRA MELLO YELLO DRAG RACING SERIES 2019 SCHEDULE

59th annual Lucas Oil NHRA Winternationals presented by ProtectTheHarvest.com
Auto Club Raceway at Pomona, Pomona, Calif. • Feb. 7-10 

35th annual Magic Dry Organic Absorbent NHRA Arizona Nationals
Wild Horse Pass Motorsports Park, Phoenix • Feb. 22-24 

50th annual Amalie Motor Oil NHRA Gatornationals
Gainesville Raceway, Gainesville, Fla. • March 14-17  

20th annual DENSO Spark Plugs NHRA Four-Wide Nationals
The Strip at Las Vegas Motor Speedway, Las Vegas • April 5-7  

32nd annual Mopar Express Lane NHRA Spring Nationals presented by Pennzoil
Royal Purple Raceway, Houston • April 12-14

10th annual NGK Spark Plugs NHRA Four-Wide Nationals
zMAX Dragway, Charlotte, N.C. • April 26-28 

39th annual Arby's NHRA Southern Nationals
Atlanta Dragway, Atlanta • May 3-5 

2nd annual Virginia NHRA Nationals
Virginia Motorsports Park, Richmond, Va. • May 17-19  

22nd annual Route 66 NHRA Nationals
Route 66 Raceway, Chicago • May 30-June 2  

31st annual Menards NHRA Heartland Nationals presented by Minties
Heartland Park Topeka, Topeka • June 7-9

19th annual NHRA Thunder Valley Nationals
Bristol Dragway, Bristol, Tenn. • June 14-16

13th annual Summit Racing Equipment NHRA Nationals
Summit Racing Equipment Motorsports Park, Norwalk, Ohio • June 20-23  

7th annual NHRA New England Nationals
New England Dragway, Epping, N.H. • July 5-7

40th annual Dodge Mile-High NHRA Nationals presented by Pennzoil
Bandimere Speedway, Denver • July 19-21  

32nd annual NHRA Sonoma Nationals
Sonoma Raceway, Sonoma, Calif. • July 26-28  

32nd annual CatSpot NHRA Northwest Nationals
Pacific Raceways, Seattle • Aug. 2-4 

38th annual Lucas Oil NHRA Nationals
Brainerd Int'l Raceway, Brainerd, Minn. • Aug. 15-18 

65th annual Chevrolet Performance U.S. Nationals
Lucas Oil Raceway at Indianapolis, Indianapolis • Aug. 28-Sept. 2  

COUNTDOWN TO THE CHAMPIONSHIP

35th annual Mopar Express Lane NHRA Nationals presented by Pennzoil
Maple Grove Raceway, Reading, Pa. • Sept. 12-15  

8th annual AAA Insurance NHRA Midwest Nationals
Gateway Motorsports Park, St. Louis • Sept. 27-29  

12th annual NHRA Carolina Nationals
zMAX Dragway, Charlotte • Oct. 11-13  

34th annual AAA Texas NHRA Fall Nationals
Texas Motorplex, Dallas • Oct. 17-20  

19th annual Dodge NHRA Nationals presented by Pennzoil
The Strip at Las Vegas Motor Speedway, Las Vegas • Oct. 31-Nov. 3  

55th annual Auto Club NHRA Finals
Auto Club Raceway at Pomona, Pomona, Calif. • Nov. 14-17  



Pro Stock competition



Pro Stock Motorcycle competition

THE BASICS OF DRAG RACING

What is a drag race?



The sport of drag racing is an acceleration contest between two vehicles racing from a standing start over a straight race course. A drag racing event is made up of a series of individual two-vehicle races called eliminations, with competing machines divided into a variety of classes. Class eligibility is governed by criteria that limit engine size, type of fuel, vehicle weight, allowable modifications, and aerodynamics.

A set of lights, commonly called a “Christmas Tree,” is used at the starting line. There is a .4-second difference between the flash of all the amber lights and the flash of the green light in the Pro start system. In handicap racing, the amber lights illuminate individually, with a .5-second difference between the last amber and the green. Upon leaving the starting line, each contestant activates a timer, which is then stopped when his or her vehicle reaches the finish line. The start-to-finish clocking is the vehicle’s elapsed time (e.t.), which serves to measure performance and often to determine handicaps during competition.

Virtually anyone can compete in drag racing. Drivers must have a valid state- or government-issued driver’s license beyond a learner’s-permit level or, in some cases, an NHRA competition license and must be capable of the safe operation of the vehicle. The vehicle must meet basic safety criteria (brakes, seat belt, etc.). This applies to most street-type vehicles. Faster, all-out race cars must meet more stringent requirements as outlined throughout this NHRA Rulebook.

It is essential for every participant to understand this fundamental rule of drag racing: Prime responsibility for the safe condition and operation of a vehicle in competition rests with the vehicle owner, driver, and crewmembers. The track operator’s main concern is to provide a place to conduct events. NHRA produces guidelines based on experience and circulates information to help perpetuate the sport. Close observance of the standards set forth in this Rulebook is required for all participants, including owners, drivers, and crewmembers. However, drag racing is dangerous. Therefore, no express or implied warranty of safety is created from publication of or compliance with NHRA rules, nor does compliance with NHRA rules guarantee against injury or death to participants, spectators, or others.

Though some choose to race vehicles they build to certain specifications to fit into a certain NHRA class (outlined elsewhere in this Rulebook), an ever-growing number of racers choose to compete on a local level in categories divided on the basis of performance, or e.t. (elapsed time), brackets. This form of drag racing offers a good starting point for the novice wishing to become involved in the sport. Thousands of drag racers enjoy E.T. handicap racing, which allows drivers in slower vehicles to compete on an equal basis with drivers of quicker and faster machines. The performance predictions for all vehicles are compared, and the slower car receives an advantage at the start equal to the difference between the vehicles' anticipated e.t.s. For example, a vehicle with a dial-in of 15.75 will have a 2.5-second head start over a vehicle with a dial-in of 13.25.

With this system, virtually any two vehicles can be paired in a competitive drag race. It is designed so that if both vehicles cover the race distance in exactly the predetermined elapsed time, the win will go to the driver who reacted quickest to the starting signal. That reaction to the starting signal is called "reaction time." Each lane is timed independently, and the clock does not start until the vehicle actually moves. Because of this, a vehicle may sometimes appear to have a mathematical advantage in comparative elapsed times but will actually lose the race. This fact makes starting-line reflexes extremely important in drag racing.

In most cases, the vehicle that gets to the finish line first wins. An exception: When both vehicles run quicker than their dial-in, known as a "double-breakout race," the vehicle closest to its dial-in is the winner. For instance, if both vehicles have a dial-in of 8.90 and one breaks out at 8.854 and the other at 8.864, the vehicle that ran 8.864 wins.

Another form of disqualification is a foul start, or "red-light." This happens when the driver reacts to the Tree too quickly and drives away from the starting line before the green go signal. Should dual infractions occur — a red-light and a breakout, for example — the driver who red-lights would be classified as committing the worse infraction and lose.

Hence, the start is key, because all races start from a standstill. Today's modern starting system is a product of continued development, designed to provide each competitor with the fairest start possible. The Christmas Tree system features a vertical series of lights, displaying a visual countdown for each racer. Technique in staging and starting is one of the most vital skills a drag racer can develop because a majority of races are won or lost at the starting line. Close observation and practice can pay off.

Two performances are monitored for each run: elapsed time and speed. The elapsed time is started when the vehicle first leaves the starting line, breaking the beam that activates the electronic timer. As the vehicle continues down the course, the timer records the elapsed seconds until it breaks the finish-line beam and stops the timer. Speed is determined by two additional light beams at the finish line.

The wide variety of classifications in NHRA Championship Drag Racing provides a showcase for everyone's favorite type of vehicles and assures excitement for fans and drivers alike, whether driven by passion for the automobile, vehicle appearance, or speed.

NHRA NATIONAL EVENT STARTING-LINE SYSTEM

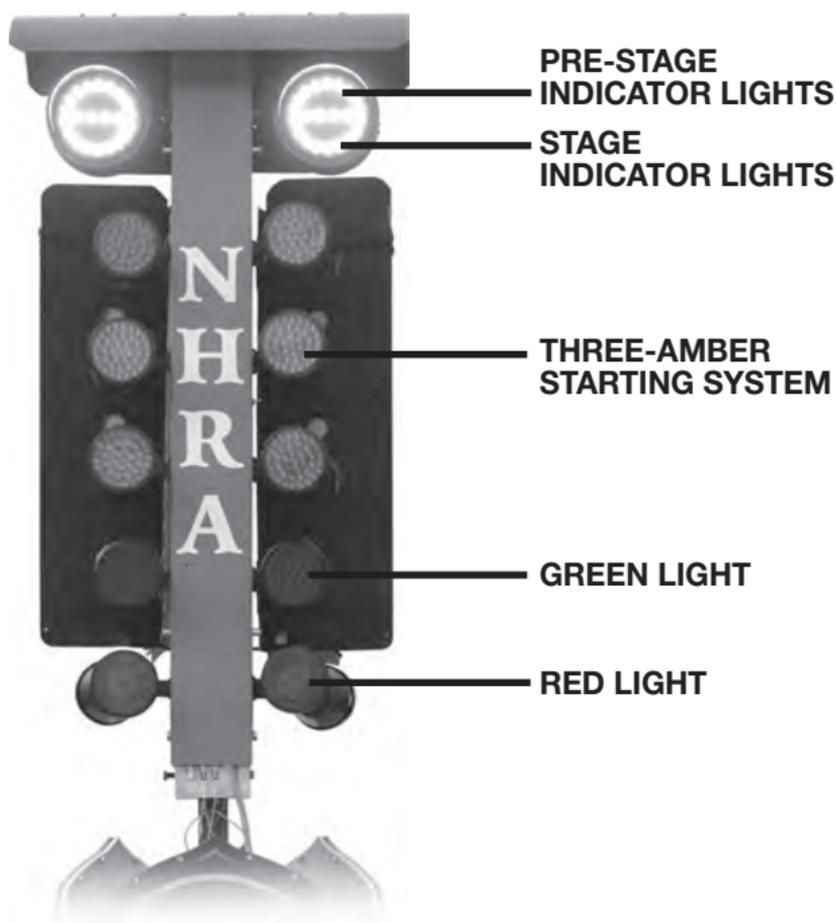

PRE-STAGE INDICATOR LIGHTS: Warns racers that they are approaching the starting line and the “staged” position.

STAGE INDICATOR LIGHTS: Signal racers that they are on the starting line and ready for a run. These lights are turned on when the front wheels of the race vehicle interrupt the beam from a light source to the photo cells that also triggers the timing equipment when the vehicle leaves the light beams.

THREE-AMBER STARTING SYSTEM: In the Pro start system (for heads-up categories), all three ambers/LED lights in a racer’s lane flash simultaneously .4-second before the green light comes on. Racers running in handicap categories get a countdown of one amber light at a time, .5-second apart, before the green light.

GREEN LIGHT: This is the one that makes it all happen. Once the green light flashes, the racer in that lane is free to make a run down the track. Anytime a green light is shown in a racer’s lane, it indicates that a fair start was accomplished.

RED LIGHT: When the front wheel of a vehicle leaves the starting line before the green light comes on, the red light will flash in that lane to indicate that the racer in that lane has been disqualified. During competition, only one red light will flash, thus eliminating only the first offender.

NHRA MELLO YELLO DRAG RACING SERIES



The NHRA Mello Yello Drag Racing Series brings the quickest form of motorsports to multiple markets in the United States each season, showcasing competition in the categories of Top Fuel, Funny Car, and Pro Stock at all events and Pro Stock Motorcycle at a select number.

Professional drivers and teams present 10,000-horsepower, nitromethane-burning cars as well as the quickest Pro Stock cars and motorcycles with an ever-growing fan base watching the action.

Top Fuelers, the “kings of the sport,” and Funny Cars use 500-cid, nitromethane-burning engines that produce 10,000 horsepower. The 300-inch-wheelbase Top Fueler is quicker than the Funny Car, which is less than half as long and has a carbon-fiber-replica production-car body. The fire and thunder they produce create a sensory experience unequalled in all of motorsports, one that must be seen and heard to be believed.

Pro Stockers more closely resemble production vehicles but are nonetheless highly sophisticated race cars. With basically stock body contours and minimal aerodynamic aids, they record elapsed times of less than seven seconds at more than 200 mph using an engine of 500 cid, spec racing gasoline, and electronic fuel injection. The competition in Pro Stock is some of the closest in motorsports; races are often decided by just a few thousandths of a second.

Pro Stock Motorcycle is the two-wheel category in the NHRA Mello Yello Drag Racing Series. Competitors rely on spec racing gasoline to produce elapsed times of less than seven seconds at speeds in excess of 195 mph.

To get a close look at these machines and the people who race them, visit one of the NHRA Mello Yello Drag Racing Series events listed on page v or on NHRA.com.



NHRA LUCAS OIL DRAG RACING SERIES



Many of the future stars of NHRA Championship Drag Racing develop their skills in the NHRA Lucas Oil Drag Racing Series. The premier Sportsman racing program in motorsports, the NHRA Lucas Oil Drag Racing Series showcases competition in eight categories, highlighted by the 260-mph Top Alcohol Dragsters and Top Alcohol Funny Cars, as well as Comp, Super Stock, Stock, Super Comp, Super Gas, and Super Street. Racers compete for national, regional, and divisional championships and a share of the more than half a million dollars in prize money.

In seven geographic regions of North America, more than 40,000 licensed racers can score points toward divisional, regional, and national championships at a select number of events. Drivers in the alcohol classes earn points toward regional titles, and drivers in the remaining classes run for divisional titles. The season runs from February through November.

Run in conjunction with the NHRA Lucas Oil Drag Racing Series is a popular program for each division's best racers: the JEGS Allstars. Drivers score points at divisional races toward qualifying for the Allstars tournament, held at the Fallen Patriots NHRA Route 66 Nationals presented by K&N Filters at Route 66 Raceway in May. Boasting a \$124,000 purse, the JEGS Allstars is one of the most lucrative single-day events in Sportsman racing.

For the location of the nearest racetrack hosting an NHRA Lucas Oil Drag Racing Series event, log on to NHRA.com/prosportsman, NHRARacer.com, or call your local division office.



E3 SPARK PLUGS NHRA PRO MOD DRAG RACING SERIES PRESENTED BY J&A SERVICE



The E3 Spark Plugs NHRA Pro Mod Drag Racing Series presented by J&A Service, introduced in 2010, features supercharged or turbocharged, methanol-burning or nitrous-oxide-injected, gasoline-burning full-bodied cars. The existence of the E3 Spark Plugs NHRA Pro Mod Series is dependent upon sponsorship funding.

Featuring unique doorslammers, highlighted by '68 Camaros, '67 Mustangs, and '68 Firebirds as well as a variety of late-model muscle cars, the E3 Spark Plugs NHRA Pro Mod Series offers something for every kind of hot rodding enthusiast. With huge slicks at the rear and superchargers poking through the hoods, there's no doubt that these cars are a whole lot more than souped-up classics.



NHRA SUMMIT RACING SERIES



The NHRA Summit Racing Series that is contested across North America forms the world's largest motorsports program in terms of racer participation. Participating NHRA member tracks across North America host regularly scheduled events and award points. At the end of the season, each track selects a team of racers from among its top points finishers to represent the track in a divisional Summit Racing Series Finals. Competitors — running in different categories based on performance — race until a champion is crowned in each category. Points totals also are tallied for team honors.

Division champions in Super Pro, Pro, Sportsman, and Motorcycle are eligible to compete at the season-ending Auto Club NHRA Finals in Pomona, Calif., to determine a national champion. In addition to the lucrative Summit prize fund, many manufacturers post contingency awards, making the final payouts indeed worthy of the caliber of racing.

Run in conjunction with the NHRA Summit Racing Series is a popular program for high school students. Each participating track holds special High School eliminators, and a student is selected to represent the track at the NHRA Summit Racing Series Finals in each division.

A breakdown of rules regarding construction and preparation of vehicles for Summit Racing Series competition is in Section 4 of this Rulebook. Novice racers are invited to ask for advice in getting started in the sport. To do that and to find the location of the nearest racetrack, call NHRA headquarters, 626-914-4761, or your local NHRA division office (listed on page iv). An up-to-date listing of member tracks is also on NHRA.com: NHRA.com/member-track-locator.



NHRA SUMMIT RACING JR. DRAG RACING LEAGUE



The NHRA Summit Racing Jr. Drag Racing League was born when Vincent Napp, the late owner of Old Bridge Township Raceway Park in Englishtown, N.J., built a half-scale dragster for his son, David. The creation was quite a sensation and was the catalyst for what is now known as the NHRA Summit Racing Jr. Drag Racing League.

In this family-oriented program, kids can begin preparing for a career or hobby in drag racing long before they can even obtain a state driver's license.

Formed in 1992, the Jr. Drag Racing League is a multifaceted program designed to afford youth as young as 5 years old the opportunity to drive in the League and those 6 to 17 the opportunity to race against their peers in near replicas of the models that the Pros drive. NHRA Jr. drag racers are restricted to competition in half-scale rear-engine dragsters over a maximum distance of an eighth-mile. Racers are permitted a single-cylinder, four-cycle, NHRA-accepted engine. However, because racing is conducted in an elapsed-time, dial-your-own format (similar to E.T. handicap) or with a preset index on a heads-up, breakout basis (similar to Super Comp and Super Gas), engine modifications are allowed. Racing gasoline or methanol may be used as a fuel.

Drivers who are 5 years old may not run quicker than 20.00 seconds on the eighth-mile and may make only noncompetition single passes. Drivers who are 6 to 7 are restricted to eighth-mile elapsed times of 13.90 seconds or slower. Drivers 8 to 9 are restricted to eighth-mile elapsed times of 11.90 seconds or slower. Drivers 10 to 12 are held to eighth-mile elapsed times of 8.90 seconds or slower. Drivers 13 to 17 may run as quick as 7.90 in the eighth-mile.

During the summer, Jr. drag racers who have qualified in local competition at NHRA member tracks around the country travel to one of two NHRA Jr. Drag Racing Conference Finals. There, drivers compete for an Eastern or Western Conference title in eight age brackets.

The NHRA Summit Racing Jr. Drag Racing League Rulebook contains complete rules for construction of a Jr. Dragster. Membership in the NHRA Summit Racing Jr. Drag Racing League is required to race a Jr. Dragster. To purchase a print copy of the NHRA Summit Racing Jr. Drag Racing League Rulebook, log on to member.nhra.com/Members/Shop/Members/Shop/Store_Home.aspx or call 800-308-6472. For information about the NHRA Summit Racing Jr. Drag Racing League, log on to JrDragster.NHRA.com.



NHRA DRAGS: STREET LEGAL STYLE PRESENTED BY AAA

Drag racing can trace its roots to local streets — anywhere a straight piece of asphalt and a set of traffic signals existed. In the early 1950s, NHRA worked with local law-enforcement agencies around the country to entice such traffic-light racers off the streets and onto dry lakes and abandoned runways, where more organized competition could be staged. From those humble origins, the sport of NHRA Championship Drag Racing was born.



Unfortunately, not everyone participates in legitimate, organized events. Many still choose to race illegally on public streets.

Recognizing the seriousness of the problem, NHRA established relationships with law-enforcement agencies throughout the country. Through these relationships, the NHRA Drags: Street Legal Style presented by AAA program was born. One of the most effective tools in the fight against illegal street racing is the establishment of Street Legal events at NHRA member tracks.

This category is reserved for foreign and domestic production-type automobiles and trucks. All vehicles must be street driven and carry proof of vehicle registration and valid insurance. Vehicles must also display valid license plates. Vehicles running in the Street Legal category must be able to pass all state highway safety requirements for the state in which the vehicle is registered.

Additionally, requirements and specifications for Street Legal and other local NHRA member track events are the same as those for the Summit Racing Series with the following exception. 2008 OEM model-year and newer production cars running slower than 9.99 (*6.39) and 135 mph do not have to meet the requirements and specifications for the Summit Racing Series except for the following: Convertibles and T-tops must meet Summit Racing Series roll-bar and roll-cage requirements. Vehicle must pass all highway safety requirements in the state in which the vehicle is registered. Unaltered OEM installed anti-lock brakes, airbag functions, as well as all other OEM safety related systems must be functioning as per manufacturer's specifications. Note: Tires used may be other than OEM, but they must be DOT-approved, All drivers must meet the Summit Racing Series helmet and protective-clothing requirements for the e.t. and mph of vehicle.

At Street Legal events, only legitimate street-legal machines are permitted to participate. Though competition structure varies from track to track, emphasis is placed on fun. A common Street Legal venue will feature time trials and grudge racing only, which ensures each participant the opportunity for a maximum number of passes down the dragstrip. Grudge racing permits participants to choose their competition rather than participate in an organized eliminator. And, once eliminated, a participant may return to the staging lanes for more time trials or grudge runs. Being eliminated at a Street Legal event does not necessarily mean it's time to go home.

Street Legal events provide a legal environment where you can drag race. Have fun!

NHRA JR. STREET



Pop culture observers who think young people's interest in cars is waning seem to have difficulty explaining a growing interest in motorsports among America's youth. In fact, to help meet the demand for teenagers wanting to drive fast, NHRA offers a racing program for 13-16-year-olds that combines racing and car safety.

NHRA Jr. Street gives teenage boys and girls the opportunity to race against their peers with an approved licensed supervising adult as a teammate. Competitors will go through an orientation/licensing procedure on an eighth-mile dragstrip in their vehicles, which must meet program requirements. Approved vehicles must be registered, insured, street-legal vehicles with mufflers and street tires and run 9 seconds and slower.

NHRA Jr. Street is for drivers of full-bodied cars, trucks, vans, or SUVs. Prohibited vehicles include open-top SUVs or open-top SUV-type vehicles. Convertible tops are allowed but must be closed at all times. Motorcycles and race cars are prohibited. All vehicles must be street-legal and driven in the gate. Vehicles must also have the correct state issued license plate (dealer tags, paper tags, temporary tags, etc. prohibited), a valid state vehicle registration, a valid state inspection (if required), and proof of current insurance. Vehicles must be able to pass all state highway safety requirements for the state in which the vehicle is registered.

Participants may not compete in any other class except Jr. Dragster. As part of the membership purchase necessary for this program, participants also receive the digital edition of award-winning NHRA National Dragster magazine and excess medical insurance (coverage may be different outside the United States).

All of NHRA's member tracks are eligible to conduct NHRA Jr. Street activities. Those interested in competing should contact a member track by using the Member Track Locator at NHRA.com. Program rules begin below.

NHRA Jr. Street is the latest program in NHRA's youth racing segment that also includes the NHRA Summit Racing Jr. Drag Racing League, NHRA Drags: Street Legal Style presented by AAA, and the NHRA Summit Racing Series.

REQUIREMENTS & SPECIFICATIONS

SUPPORT GROUP: 9

OPERATION

Participant may only drive the vehicle from the staging lanes to the starting line, on the track, and on the return road as far as the time-slip booth. The licensed supervising adult must drive the vehicle at all other times.

DRIVER: 10**AGE REQUIREMENTS**

Licensed participants must be at least 13 years old and may participate through the year of their 16th birthday.

LICENSED SUPERVISING ADULT

All runs must be made with an approved licensed supervising adult, who must be the participant's parent or legal guardian or 25 years of age or older with a valid state driver's license. The licensed supervising adult must be seated in the passenger seat of the vehicle anytime the participant is in the driver's seat. The teen may only drive the vehicle from the staging lanes to the starting line, on the track, and on the return road as far as the time-slip booth. The licensed supervising adult must drive the vehicle in the pits, into the staging lanes, and must take over after the run on the return road past the time-slip booth.

CREDENTIALS

A valid NHRA Jr. Street program participant license and NHRA membership are mandatory. License application must be fully completed and submitted to NHRA in Glendora, Calif., for processing. License application available at NHRARacer.com. All new license applications must include a certified copy of the participant's birth certificate and a completed and notarized minor waiver and release.

Six (6) approved passes are required by the participant: a minimum of five (5) with a licensed supervising adult and one (1) with an NHRA track official, who will determine the safety and eligibility of the vehicle per elapsed time limits. After six (6) successful runs by the participant, the official and licensed supervising adult will sign the license application. An NHRA track official may deny a license to anyone he or she believes cannot handle the vehicle. If an NHRA track official denies an applicant, he or she must repeat the entire licensing procedure.

As part of the licensing process, an NHRA track official also will conduct a vehicle orientation test (to demonstrate mastery of vehicle's controls), a basic driving test (to demonstrate mastery of vehicle operation), and track orientation (to identify track fixtures, starting line, timing system, return road, time-slip booth, etc.). A vehicle orientation test is required for each vehicle entered in competition. An NHRA track official or licensed supervising adult must be in the vehicle at all times during the licensing procedure.

To add a vehicle, the participant must complete a vehicle orientation test, basic driving test, and safety and eligibility vehicle test and make two (2) approved runs with a licensed supervising adult and one (1) approved run with an NHRA track official. Participant must hold an active membership in the NHRA Jr. Street program.

DRIVER RESTRAINT SYSTEM

Use of seat belts is mandatory for both the participant and licensed supervising adult.

HELMET

Helmets are mandatory for the participant and the licensed supervising adult. Helmet can be either an open-face or a full-face helmet meeting Snell M2010, SA2010, SA2015 or 31.1/2010, 31.1/2015, 41.1/2010, or 41.1/2015 certification.

PROTECTIVE CLOTHING

No shorts, bare legs, tank tops, or bare torsos permitted while racing (applies to both participant and licensed supervising adult).

NOTICE

Drag racing is a dangerous sport. There is no such thing as a guaranteed safe drag race. Drag racing always carries with it the risk of serious injury or death in any number of ways. This risk will always exist no matter how much everyone connected with drag racing tries to make our sport safer. Although NHRA works to promote and enhance the safety of the sport, there are no guarantees that such safety measures will guarantee or ensure safety. The participant always has the responsibility for the participant's own safety, and by participating in drag racing, the participant accepts all risks of injury, whether due to negligence, vehicle failure, or otherwise. If at any time a participant does not accept these risks, the participant agrees not to participate in drag racing.

HOW TO USE THIS RULEBOOK

The NHRA Rulebook provides guidelines and minimum standards for the construction and operation of vehicles used in NHRA Championship Drag Racing and at member-track events. It is the responsibility of the participant to be familiar with the contents of this Rulebook and to comply with its requirements. Do not leave it up to track officials to catch all potential rule compliance problems. That responsibility rests first and foremost with YOU — the participant.

Additional safety equipment or safety-enhancing equipment is always permitted and the levels of safety equipment stated in this Rulebook are minimum prescribed levels for a particular type of competition and do not prohibit the individual racer from using additional safety equipment. Participants are encouraged to investigate the utility of additional safety devices for your type of competition. In disputed cases, whether an item of equipment is safety-enhancing or performance-enhancing will be determined by NHRA in NHRA's sole and absolute discretion.

On the other hand, as to performance equipment, it is the general rule that unless optional performance equipment or performance-related modification is specifically permitted by this Rulebook, it is prohibited. All model, engine, or equipment changes or modifications not specifically addressed in this Rulebook must be submitted in writing to NHRA for consideration prior to competition. Approval will be granted or denied in NHRA's sole and absolute discretion. The applicant will be notified of approval or rejection in writing from NHRA headquarters in Glendora, Calif.

Additionally, any type of vehicle not specifically defined in this Rulebook, other official NHRA Rulebooks, or other official NHRA supplements is prohibited for use in competition or exhibition.

Throughout this Rulebook, a number of references are made for particular products to meet certain specifications

(i.e., SFI Specs, Snell, DOT, etc.). It is important to realize that these products are manufactured to meet certain specifications, and upon completion, the manufacturer labels the product as meeting that spec. Therefore, except as outlined under SFI requirements, any change to the product voids that certification.

Under no circumstances may any certified product be modified, altered, or in any way vary from the “as manufactured” condition. Such a practice is in violation of the SFI, Snell, DOT, etc. program, voids such certification and therefore will not be accepted by NHRA.

NOTICE: It is the responsibility of the participant, not NHRA or any track, to ensure that all safety equipment is approved and is correctly installed, worn, maintained, and used.

Unauthorized cars, parts, and/or equipment will not be considered approved by reason of having passed through technical inspection at any time, or any number of times. Moreover, having passed through technical inspection at any time, or any number of times, is not a defense to a violation found on further inspection.

The Rulebook divides these guidelines and standards for the construction and operation of vehicles into two basic groups:

Requirements & Specifications: The minimum standards that differentiate the various categories of competition vehicles.

General Regulations: Guidelines that concentrate on specific areas of construction or operation of a vehicle. Many guidelines in the Rulebook are applicable to many or all categories. General Regulations provides a central location for the description of those guidelines.

Both Requirements & Specifications and General Regulations are further divided into 11 subcategories: 1-Engine, 2-Drivetrain, 3-Brakes & Suspension, 4-Frame, 5-Tires & Wheels, 6-Interior, 7-Body, 8-Electrical, 9-Support Group, 10-Driver, and 11-General.

In many instances, the Requirements & Specifications for a particular class will reference a General Regulations section. For example, in Section 4A, Liquid Overflow, the paragraph ends with the sentence “See General Regulations 1:7.” By turning to General Regulations, Section 1:7, Liquid Overflow, you will find additional information about mounting the overflow container and routing the overflow hoses. Because this information applies to virtually all categories, it would be repetitive to reprint it in each individual category’s Requirements & Specifications. It is, nonetheless, important information to the competitor and/or builder. (An index of General Regulations is at the beginning of that section.)

Conversely, General Regulations may refer the reader back to Requirements & Specifications by stating “See Class Requirements.” The majority of minimum standards found in the Rulebook are based on the performance level of the vehicle. However, certain categories classed by cubic inch to weight or horsepower to weight have additional rules and regulations that limit the parameters within which a particular

performance level may be reached. For example, Section 7:4, Firewall, General Regulations describes the minimum standards for construction of a firewall or bulkhead separating the driver from the engine compartment. Section 7:4 also states “See Class Requirements.” If you were considering building a Stock vehicle and turn to Firewall in the Stock section, the Rulebook states “Alterations prohibited unless expressly permitted in this section. Firewall coverings prohibited.” This, then, negates construction of a minimum firewall by requiring the original, unaltered OEM firewall. Before deciding which standards are applicable to your vehicle, Class Requirements AND General Regulations must both be considered.

Another key to understanding the NHRA Rulebook is that certain classes “build” from another.

When the Rulebook states “Requirements and Specifications for ... are the same as those for ...” you must read the referenced section first. For example, before reading Section 4B, Advanced E.T., one must first understand Section 4A, Super Pro, Pro, Sportsman. Before reading the Super Gas section, one must first read the Super Street section. If a particular requirement is mentioned in the Super Street section and not in the Super Gas section, then the requirement is the same in both categories.

If after reading the Rulebook you still have questions, consult page xiv for hours and phone numbers where tech personnel may be reached. These phone lines are extremely busy, so prepare your questions in advance.

Remember, it is your responsibility to follow the standards in this Rulebook that pertain to your vehicle.

Administrative Procedures & Appeals Index

Definitions	1
Scope of NHRA Rulebook.	2
Voluntariness; Participation Not a Right; All Participants Bound by the Rulebook; Participant Conduct; Covenant Not to Sue	3
Finality of Decisions by Event Director, Designees or Other Event Officials.	6
Assumption of Risk and Release and Waiver of Liability	7
Licensure; Technical Inspection; Protest Procedures; Retention of Vehicles and Parts	9
Substance Abuse Policy	13
Rule Enforcement; Review and Appeals; Exclusive Mechanism for Dispute Resolution . . .	18
Publicity.	25
Proprietary Rights	30
Contingency Awards	31
Professional Category Owner Groups.	31
Environmental Management Responsibilities for All Participants	32

SECTION 1 ADMINISTRATIVE PROCEDURES & APPEALS

Participant Agreements and Administrative and Procedural Rules; Rule Changes; Rule Enforcement; Dispute Resolution Procedures

1.1 DEFINITIONS

Certain terms used in this Rulebook are defined terms which, when used herein, have the meaning set forth below:

Participant: The term “participant” shall include officials, any person or entity possessing or who has been issued a credential, and any person or entity directly or indirectly associated with any vehicle that has been permitted to enter an event site for the purpose of participation in an event, including, but not limited to, owners, drivers, and crewpersons. The term “participant” shall include any person or entity that has any ownership interest in a race team, vehicle, or otherwise. As to any entity, the term “participant” shall include each of the entity’s owners, principals, agents, parents, subsidiaries, divisions, partners, affiliates and other related persons or entities. NHRA may require at any time and from time to time that verified information regarding team and/or vehicle ownership, crew members and other information be supplied.

Event: Throughout this Rulebook, there is reference to “event” or “events.” Wherever this term is used, it is intended to refer to two types of drag racing activities: (1) NHRA events, which are

those events that NHRA conducts. These include but are not limited to events such as NHRA Mello Yello Drag Racing Series events, NHRA Lucas Oil Drag Racing Series events, National Opens, and the like; and (2) drag racing events conducted at NHRA member tracks which NHRA does not conduct but that are conducted in accordance with NHRA Rules.

1.2 SCOPE OF NHRA RULEBOOK

The principal source of authority for the conduct of events is the NHRA Rulebook. The Rulebook governs all decisions at NHRA events and governs all NHRA matters affected by the Rulebook. Each and every participant is bound by the Rulebook and is held responsible for knowledge of and compliance with the Rulebook. Ignorance or misunderstanding of a rule does not excuse noncompliance. Participants' knowledge of and compliance with the Rulebook contributes to the safety of the sport and is required. By participating in the sport, every participant affirms that he or she has read, understands and agrees to be bound by all NHRA rules and regulations, including those contained in the NHRA Rulebook, including amendments.

NHRA has developed and published this Rulebook for the purpose of providing guidance in the conduct of NHRA events and events conducted at NHRA member tracks, and as to all aspects of participation in NHRA, whether or not related to an event. NHRA makes no representations or express or implied warranties that compliance with the rules, regulations and agreements published in this Rulebook or as amended will reduce, prevent or guarantee against injury or death to spectators or participants or damage to property or other economic injury or damages. The rules, regulations, and agreements herein constitute the minimum acceptance standards for competition and are intended as a guide for the conduct of the sport. NHRA does not intend to imply by the publication of the Rulebook, by the conduct of various racing events, by the licensing of drivers, by the acceptance of event entries, or by any other act or omission to act that any person has the right or the inalienable privilege of participating in NHRA events and/or NHRA member track events.

1.2.1 Development of NHRA Rules

Since it was founded by Wally Parks in 1951, NHRA has promulgated rules to govern its sport. Thus, over five decades of experience have shaped, and continue to shape, the NHRA rules. The development of NHRA rules is based on many considerations. Some factors affecting NHRA rulemaking include promoting participant safety; promoting spectator safety; preserving competition; even competition; insurance preservation; costs to participants such as, for example, costs that would have to be incurred if new equipment were allowed and/or mandated; attempts to contain costs being experienced by competitors to ensure continued competition; preserving the ability to race in various geographic locations; concerns affecting television coverage of those events for which television coverage is provided; costs to NHRA; regulating or containing the performance of racing vehicles to address safety and other considerations; other safety and security matters, and numerous other factors that affect the complex and intricate issues with which NHRA, as a sports sanctioning body, must deal and balance.

1.2.2 New Rules and Rule Changes

NHRA rules may be added, deleted and/or amended from time to time and at any time by NHRA. **It is the participant's responsibility to stay abreast of all NHRA rule changes that**

Section 1, page 3 Administrative Procedures & Appeals

may affect the participant. Additions, deletions or changes to the Rulebook (collectively referred to herein as “amendments”) will be communicated as follows:

1. Publication in NHRA National Dragster; and/or
2. Publication on NHRARacer.com

Amendments are effective and enforceable immediately upon publication on NHRARacer.com or in NHRA *National Dragster*. Racers are responsible to consult and stay up to date with any rules and related information published on NHRARacer.com. Amendments will be labeled as amendments to the Rulebook.

Amendments may but need not be published once in NHRA *National Dragster*, but always are published on NHRARacer.com. Publication in NHRA National Dragster shall be done in NHRA’s discretion. In NHRA’s discretion, an amendment or group of amendments may be listed or referred to in NHRA National Dragster with the full text being available only on NHRARacer.com, or may solely be published on NHRARacer.com. NHRARacer.com generally will contain an index of amendments for the then current year, and that index may be published in NHRA *National Dragster* as well, in NHRA’s discretion.

1.2.3 Other NHRA Policies and Procedures

In addition to the Rulebook, NHRA has set various policies and procedures that also provide guidance for the conduct of racing and events and are enforceable by NHRA. These items include, without limitation, Competitor Data Sheets, NHRA-accepted products, technical bulletins, and other policies and procedures.

1.2.4 Official Opinions on Technical Issues

Participants may request official opinions on technical issues from NHRA. This type of opinion may be requested, for example, on the acceptability of specific items of equipment or body designs. Any request for an official opinion on technical issues must be made in writing and submitted to the Technical Department. No opinion on technical issues is binding on NHRA unless published in NHRA *National Dragster* or, if deemed too lengthy for publication in NHRA *National Dragster*, then referred to in NHRA National Dragster and published on NHRARacer.com.

1.2.5 Informal Interpretations on Technical Issues

Participants may communicate with the NHRA Technical Department regarding explanations and interpretations of rules. These communications are advisory only.

1.3 VOLUNTARINESS; PARTICIPATION NOT A RIGHT; ALL PARTICIPANTS BOUND BY THE RULEBOOK; PARTICIPANT CONDUCT; COVENANT NOT TO SUE

NHRA is a private, voluntary association. While NHRA welcomes the participation of everyone, participation requires a promise and agreement by all participants to abide by all NHRA rules, regulations and agreements, including, but not limited to, those in the NHRA Rulebook. Without this promise and agreement, NHRA would not be able to function as a sport sanctioning body, and NHRA’s continuing viability would be at risk. Participation in any and every aspect of NHRA drag racing is a privilege, not a right. See Participant Covenants in Section 1.3.2 below.

1.3.1 Participant Conduct

Participants at events are expected, at all times, to conduct

themselves in a professional and non-disruptive manner consistent with good sportsmanship and NHRA's role as a family-oriented sports organization with events suitable for attendance by all and, as to those events that are televised, suitable for unrestricted viewing by the general public. Any participant who, in the sole and absolute judgment of NHRA (1) verbally or physically threatens another person; (2) uses vulgar or derogatory language; (3) engages in unsportsmanlike conduct; (4) engages in conduct detrimental to the sport of racing; (5) otherwise creates a condition or circumstance that is unsafe, unfair, or out of order; (6) is not honest and truthful in his or her dealings with NHRA, including without limitation making a false statement or creating, submitting or using a false writing or document; or (7) otherwise violates any NHRA rule, regulation or agreement, shall have violated this rule regarding participant conduct.

Any participant who NHRA believes to have a conflict of interest that does or may improperly affect fair competition shall be disqualified from participating to the extent necessary to avoid such conflict of interest. The scope of such a disqualification shall be determined in the sole and absolute discretion of NHRA.

1.3.2 Participant Covenants and Covenant Not to Sue

Each participant expressly agrees to abide by all NHRA rules, regulations and agreements, including but not limited to those contained in the NHRA Rulebook, and by NHRA decisions, whether or not related to an event. Notwithstanding any other provision of this Rulebook, by participating in, and in consideration for being allowed to participate in NHRA drag racing, and in consideration of receiving any of the numerous benefits available to participants, each participant understands, acknowledges and agrees that:

- 1) Participation in any and every aspect of NHRA drag racing is a privilege, not a right.
- 2) The participant voluntarily chooses to participate in accordance with all NHRA rules, regulations and agreements, including but not limited to those contained in the NHRA Rulebook, and by NHRA decisions, whether or not related to an event.
- 3) When a participant submits an entry for competition in an event, and the entry is accepted, the participant is obligated to compete in the event in good faith to the best of the participant's ability unless prevented from so doing by matters beyond the participant's control.
- 4) The NHRA Rulebook and the dispute resolution procedures set forth within the Rulebook apply to any and all decisions, rules, regulations, actions or omissions to act by NHRA, without limitation. For example, and not by way of limitation, decisions on the classification or reclassification of vehicles, which categories of vehicles will be professional classes, which categories of vehicles will race at national events, what types of vehicles will be allowed to race in a class, whether an event is cancelled, postponed or rescheduled, whether or how an event is televised, what types of sponsors will be allowed to be featured on race vehicles, and what types of sponsors will not be allowed on site at events at all, to name but a few, are all illustrative of the types of decisions that are governed by and may be challenged only through the dispute resolution procedures set forth in this Rulebook.
- 6) Member track officials and personnel (including without limitation member track owners, employees, contractors, agents, vendors or others) are not agents of NHRA and operate independently of NHRA.

Section 1, page 5 Administrative Procedures & Appeals

- 7) All decisions made by NHRA, including but not limited to those made during or incident to an event, are final and may not be appealed except as expressly subject to review herein, and such decisions may not be made the basis of a lawsuit. The participant further agrees to release and waive from liability and not to bring any action against NHRA, the event director, the event director's designee(s), any NHRA or track official, the racetrack operator, the racetrack owner, event sponsors, other NHRA sponsors, and all other event officials, for any loss, damage, or injury, including without limitation economic loss or damages, caused by any decision, erroneous or otherwise, including without limitation decisions based on malfunctioning electronic or mechanical equipment, and all whether due to negligence or otherwise.
- 8) Any dispute concerning the rules, regulations and agreements of NHRA, any decisions of NHRA or NHRA officials, any acts or omissions to act by NHRA, or any matter regarding participation in NHRA drag racing, shall be resolved exclusively pursuant to the dispute resolution procedures provided in this Rulebook. The participant agrees to indemnify and to hold NHRA harmless from any and all legal fees and costs incurred by NHRA as a result of the failure of the participant to comply with the dispute resolution procedures provided in this Rulebook.
- 9) NHRA, any racing facility, and all of their directors, officers, employees, agents or representatives have no liability to the participant, participant's personal representatives, assigns, heirs, and next of kin for any and all loss or damage and any and all claims or demands of any nature whatsoever including without limitation loss or damage to any property of the participant or property of others entrusted to the participant, whether caused by the negligence of any Releasee (as defined in Section 1.5.2 herein) or otherwise.
- 10) The participant will not initiate or maintain, directly or indirectly, any kind of civil court lawsuit related to any NHRA rule, regulation, agreement or decision, which lawsuit NHRA determines to be conduct detrimental to NHRA or the sport of drag racing. Factors considered in determining whether a lawsuit is deemed conduct detrimental to NHRA or to the sport of drag racing include, but are not limited to: the threat posed to maintaining the ability to conduct events and racing activities; the threat posed to the continued viability of the sport of drag racing; disruption to the orderly conduct of the sport of drag racing; damage to NHRA's business and reputation; loss of sponsorship opportunities; disruptions in sponsor relationships; damage to goodwill with vendors, sponsors, customers and members; damage to racing competition; adverse effects upon the insurability of the sport of drag racing, and other damage to NHRA or the sport of drag racing.
- 11) In order to preserve the sport of drag racing, and to preserve NHRA's ability to function and exist as a sanctioning body for drag racing, NHRA must and does rely on the foregoing covenant not to sue.
- 12) NHRA would be severely damaged by breach of the covenant not to sue set forth herein.
- 13) Taking into account the many circumstances affecting the sport of drag racing, and factors that cannot be foreseen and accurately predicted by NHRA and each participant, actual damages to NHRA resulting from breach of the covenant not to sue would be impracticable and extremely difficult to determine.
- 14) In the event of any breach of this covenant not to sue involving a lawsuit filed after May 1, 2004, unless the participant prevails in the participant's lawsuit, the participant:

- a) May be subject to permanent or temporary suspension or exclusion from NHRA events; and
- b) Must pay all of NHRA's attorneys' fees and costs related to the lawsuit, including but not limited to fees and costs for in-house counsel (payment must be made before participation, if eligible, in any NHRA event); and
- c) Must pay any fine assessed by NHRA (payment must be made before participation, if eligible, in any NHRA event).

1.3.3 Compliance With NHRA Rules, Regulations And Decisions

Participant compliance with all NHRA rules, regulations and decisions is required. NHRA has the right to take action against any participant for failure to comply with any decision, rule, or regulation of NHRA, including but not limited to failure to comply with the dispute resolution procedures set forth in the Rulebook. NHRA may in its sole and absolute discretion take the action it deems appropriate in response to any such failure to comply.

In addition to imposing any specific sanctions that may be identified herein, the action taken by NHRA may include permanent suspension from NHRA events and/or NHRA member track events; private admonishment; public admonishment; temporary suspension; probation; fines; loss of points won at various events; loss of prize money won at various events; disqualification from competition in an event or events; expulsion from an event; suspension from events; permanent exclusion from NHRA events and/or NHRA member track events; some combination of the foregoing; or such other actions as NHRA shall, from time to time, determine appropriate.

1.4 FINALITY OF DECISIONS BY EVENT DIRECTOR, DESIGNEES OR OTHER EVENT OFFICIALS

NHRA has provided for a means of review of various NHRA actions and rules. In general, however, there is no provision for review of decisions of the Event Director, the event director's designee(s), or other event officials (collectively "Event Officials"). The reason such review is not provided is to ensure that there can be finality with regard to events that are run. To provide for an appeal of all actions, inactions or decisions of Event Officials could result in a delay in the determination of literally every event. Such numerous and interminable delays would be disruptive to the sport and unacceptable to participants and spectators. While the decisions, actions or inactions of Event Officials are not appealable, NHRA reserves the right to reverse such decisions or review such actions or inactions on its own initiative if it determines, in its sole and absolute judgment, that such action is warranted.

Event Officials shall have the authority to suspend, disqualify or expel any participant from an event for violation of any of the decisions, rules, or regulations of NHRA. Because Event Officials may take actions which constitute continuing disciplinary action against participants, participants shall have the opportunity to appeal suspensions that last beyond the event in question, and fines, as provided for herein. There is no opportunity to appeal disciplinary actions completed at an event such as suspension, expulsion or disqualification from the event.

1.5 ASSUMPTION OF RISK AND RELEASE AND WAIVER OF LIABILITY

1.5.1 Assumption of Risk

Drag racing is a dangerous sport that can result in serious injury or death. Participation in all aspects of the sport is voluntary. The ultimate responsibility for participant and vehicle safety lies with the participant, vehicle owner, driver and crew members.

The participant agrees that by entering and participating in an event, the participant has had the opportunity to inspect the event site and acknowledges that the event site is safe and suitable for racing. The participant agrees that he or she will not participate in the event if he or she does not believe that the event site is safe and suitable for racing. The participant further agrees that by entering and participating in an event, the participant has had the opportunity to ascertain the staff and equipment on hand, including without limitation number and location of personnel and number and type of rescue equipment, and acknowledges that the staff and equipment are adequate and suitable for racing. The participant agrees that he or she will not participate in the event if he or she does not believe that the staff and equipment are safe and suitable for racing. The participant also acknowledges that by participating in the event, the participant may suffer bodily injury or death or loss or damage to property. The participant further acknowledges that the participant has voluntarily assumed the risk of bodily injury or death or loss or damage to property and waives any claims for bodily injury or death or loss or damage to property against NHRA, its directors, officers, employees and agents, event officials, event sponsors, racetrack operators and other participants; discharges such persons and entities from responsibility for such losses; and covenants not to sue such persons and entities for bodily injury or death or loss or damage to property.

1.5.2 Release and Waiver of Liability, Assumption of Risk and Indemnity Agreement

All participants shall be required as a condition of participation to sign all required entry forms, including but not limited to such releases as shall be required by NHRA and/or its insurers, consisting of the following or similar wording. Whether or not the participant signs such releases, the participant agrees to the terms set forth below and participant is hereby put on notice of such terms and makes such agreement either by receiving this Rulebook or by participating in the sport, or both.

In consideration of being permitted to compete, officiate, observe, work for, or participate in any way in the EVENT(S) or being permitted to enter for any purpose any RESTRICTED AREA (defined as the advance staging area, burn out area, competition area, shutdown area, staging lanes, return road area, and any other area within the barriers, fences and/or structures separating the general public from racing activities), EACH OF THE UNDERSIGNED, for himself/herself, his/her personal representatives, heirs, and next of kin

1. Acknowledges, agrees, and represents that he/she has or will immediately upon entering any such RESTRICTED AREAS, and will continuously thereafter, inspect the RESTRICTED AREAS which he/she enters and he/she further agrees and warrants that, if at any time, he/she is in or about RESTRICTED AREAS and he/she believes anything to be unsafe or unsatisfactory in any way, he/she will immediately advise the officials of such and will leave the RESTRICTED AREAS and/or refuse to participate further in the EVENT(S).

2. HEREBY RELEASES, WAIVES, DISCHARGES AND COVENANTS NOT TO SUE the promoters, participants, racing associations, sanctioning organizations or any affiliated entities thereof, track operators, track owners, officials, vehicle owners, builders and designers, drivers, crews, rescue personnel, and persons in any RESTRICTED AREA, promoters, sponsors, equipment and parts manufacturers and suppliers, advertisers, owners and lessees of premises used to conduct the EVENT(S), premises and event inspectors, surveyors, underwriters/brokers, consultants and others who give recommendations, directions, or instructions or engage in risk evaluation or loss control activities regarding the premises or EVENT(S) and for each of them, their directors, officers, agents, and employees, all for the purposes herein referred to as "RELEASEES," FROM ALL LIABILITY TO THE UNDERSIGNED, his/her personal representatives, assigns, heirs, and next of kin, FOR ANY AND ALL LOSS OR DAMAGE, AND ANY CLAIM OR DEMANDS THEREFORE ON ACCOUNT OF INJURY TO THE PERSON OR PROPERTY OR RESULTING IN DEATH OF THE UNDERSIGNED ARISING OUT OF OR RELATED TO THE EVENT(S), WHETHER CAUSED BY NEGLIGENCE OF ANY RELEASEE(S) OR OTHERWISE.
3. HEREBY AGREES TO INDEMNIFY AND SAVE AND HOLD HARMLESS the RELEASEES and each of them FROM ANY LOSS, LIABILITY, DAMAGE, FEES OR COSTS they may incur arising out of or related IN ANY MANNER TO MY ATTENDANCE AT OR PARTICIPATION IN THE EVENT(S), AND WHETHER CAUSED BY THE NEGLIGENCE OF ANY RELEASEE(S) OR OTHERWISE.
4. HEREBY ASSUMES FULL RESPONSIBILITY FOR ANY RISK OF BODILY INJURY, DEATH OR PROPERTY DAMAGE arising out of or related to the EVENT(S) whether caused by the NEGLIGENCE OF ANY RELEASEE(S) OR OTHERWISE.
5. HEREBY acknowledges that THE ACTIVITIES OF THE EVENT(S) ARE DANGEROUS and involve the risk of serious injury and/or death and/or property damage. Each of THE UNDERSIGNED also expressly acknowledges that INJURIES RECEIVED MAY BE COMPOUNDED OR INCREASED BY NEGLIGENT RESCUE OPERATIONS OR PROCEDURES OF THE RELEASEES.
6. HEREBY agrees that this Release and Waiver of Liability, Assumption of Risk and Indemnity Agreement extends to all acts of negligence by the RELEASEES, INCLUDING NEGLIGENT RESCUE OPERATIONS and is intended to be as broad and inclusive as is permitted by the laws of the Province or State in which the EVENT(S) is/are conducted and that if any portion thereof is held invalid, it is agreed that the balance shall, notwithstanding, continue in full legal force and effect.

I HAVE READ THIS RELEASE AND WAIVER OF LIABILITY, ASSUMPTION OF RISK AND INDEMNITY AGREEMENT, FULLY UNDERSTAND ITS TERMS, UNDERSTAND THAT I HAVE GIVEN UP SUBSTANTIAL RIGHTS BY SIGNING IT, AND HAVE SIGNED IT FREELY AND VOLUNTARILY WITHOUT ANY INDUCEMENT, ASSURANCE, OR GUARANTEE BEING MADE TO ME AND INTEND MY SIGNATURE TO BE A COMPLETE AND UNCONDITIONAL RELEASE OF ALL LIABILITY TO THE GREATEST EXTENT ALLOWED BY LAW. I FURTHER ACKNOWLEDGE THAT FAILURE TO WITNESS THIS FORM SHALL NOT AFFECT ITS VALIDITY.

(NOTARIAL LANGUAGE)

1.6 LICENSURE; TECHNICAL INSPECTION; PROTEST PROCEDURES; RETENTION OF VEHICLES AND PARTS

1.6.1 NHRA LICENSE AND MEMBERSHIP

A license issued by NHRA is to be used only by the driver to whom it is assigned and it is restricted to the categories listed on the license. The license is valid until its expiration date or until revoked by NHRA. The license is intended only to signify that the driver has demonstrated basic qualifications for drag racing classes up to and including the one in which the driver has qualified. The license does not convey a right but rather conveys a revocable privilege to participate in events. See General Regulations 10:4 for when NHRA membership is required. A license will not be granted if the driver does not meet the then-current medical criteria set by NHRA's medical professionals. Any driver who falsifies, omits, or causes to be falsified or omitted pertinent information on his or her medical application shall be subject to denial of such application and further disciplinary action including without limitation preclusion from participation in NHRA events. Regardless of whether an item is a Prohibited Substance under the Substance Abuse Policy (Section 1.7), all prescription medications are to be disclosed on a driver's medical application (see line 34) or if subsequently prescribed after prior application approval, the participant must immediately inform the NHRA National Field Office and request approval. Certain medications preclude licensure. Specific medical clearance by NHRA's medical professionals may be granted for selected medications and requests for clearance require the applicant's cooperation in providing requested medical records and history. Application for a competition number after licensure has been declined on medical grounds may similarly be denied.

1.6.2 Technical Inspection

At a time and place and in a manner determined by Event Officials, prior to racing activities of any nature (including without limitation competition, testing, time trials etc.), all vehicles and driver equipment must undergo a technical inspection, or have been inspected under the Extended Technical Inspection program or be subject to the National Event Technical Inspection Process, explained below. In addition, every vehicle is subject to further technical inspection at any time before, during or after an event, at the time and in the place and manner directed by any Event Official.

Any technical inspection conducted for an event remains in effect during the entire event, including any continued, postponed or rescheduled event. For all technical inspections (National Event or otherwise) responsibility for accurately completing the Tech Card and/or supplying accurate information for the Tech Card is on the participant and inaccuracies and other issues will be dealt with using all measures available to NHRA. By participating, the participant certifies that his or her vehicle and personal protective equipment will remain in good condition and the same as stated on Tech Card throughout the entire event; that the participant will in fact use all safety and personal protective equipment noted on the Tech Card; and that if anything changes from what is stated on the Tech Card, the participant will immediately notify Tech Officials on site. Falsifying a Tech Card or not complying with the Rulebook subjects participants to disqualification from the event and further disciplinary action. **National Event Technical Inspection Process:** NHRA is conducting the National Event Technical

Inspection Process at certain NHRA-sanctioned events (Mello Yello events and certain other events designated by NHRA). Under the National Event Technical Inspection Process, technical inspection typically will be during or after competition, in the sole and absolute discretion of NHRA. Under the National Event Technical Inspection Process the participant certifies the technical readiness of his or her own vehicle and personal protective equipment and fills out his or her own Tech Card for the event in advance. Like all statements made to NHRA, the participant is responsible for the truth and accuracy of everything reported on the Tech Card. NHRA Tech Officials will conduct spot-checks and may at any time exercise any other rights NHRA has under the Rulebook, including tear-down and other forms of tech inspection.

NHRA may at any time inspect, seal for inspection, and/or tear down a participant's vehicle. Not complying in full with any inspection request will result in disqualification for further competition and such other penalties as deemed appropriate by NHRA. **All determinations by Event Officials regarding the timing and method of technical inspection shall be final and not subject to appeal or review. Technical inspection assists Event Officials with determining, in their judgment, eligibility for participation in an event. The technical inspection does not ensure that the vehicle or any part thereof is safe. The technical inspection does not in any way change the fact that the driver, the crewmembers, and the vehicle owner are ultimately responsible for the safety and operation of the vehicle and equipment.** By conducting a technical inspection, NHRA and its member tracks, and each of their respective directors, officers, employees and officials, make no representations, warranties, or assurances that a technical inspection, including the review of any written information, will do any or all of the following:

- 1) Detect every or any problem with a vehicle, or a driver's personal equipment or clothing; or
- 2) Detect every problem with rule compliance; or
- 3) Prevent injury, death or property damage.

The participant agrees that participant bears the ultimate responsibility at all times to ensure the safety of participant's vehicle, equipment and clothing and compliance with all NHRA rules, regulations, and agreements, including but not limited to those contained in the Rulebook. The participant agrees that participant is in the best position to know about the construction and operation of participant's vehicle, equipment, and clothing, and whether there has been compliance with all NHRA rules, regulations and agreements, including but not limited to those contained in the Rulebook. Moreover, in the case of technical violations, the participant acknowledges, understands and agrees that the participant is charged with full knowledge of every component of participant's vehicle and that even if a third party (for example, an engine builder) has caused the participant's vehicle to be noncompliant, the participant will still be responsible for and charged with any applicable violation and sanction. Disclaiming knowledge of the particular part or parts, or disclaiming knowledge of the rule or rules, or disclaiming responsibility for the actions of the third party, will not be defenses to any violation or any sanction therefor.

The weighing and measuring devices used by Event Officials shall be the standards that will determine an engine's or vehicle's compliance with the rules. Any latitude or tolerance must be made by the racer or engine builder. It is recommend

Section 1, page 11 Administrative Procedures & Appeals

that the following tolerances be observed by the participant to allow for a margin of error during inspection or teardown: Cylinder head or piston volume, 1 percent of 1 cc; deck clearance, .001-inch; overbore, .002-inch; vehicle weight, 1/2 of 1 percent or 20 pounds.

Contestants in all classes calculated by weight to cubic inch must claim calculated engine displacement to determine exact vehicle weight on window sticker. Any engine changes made must be reported to the NHRA Technical Department for proper registration before any further runs are made. After a competitor's vehicle has been inspected and classified, no changes of class are permitted.

In order to facilitate technical inspection, NHRA may, from time to time, accept certain products as having met minimum requirements for technical inspection, test certain elements of vehicles, and certify compliance of such elements as complying with minimum requirements for technical inspections, and take other similar actions. The acceptance or certifications made by NHRA are for the sole purpose of communicating compliance to NHRA technical inspectors, and shall not constitute any warranty, express or implied, including without limitation any warranty of merchantability or fitness for a particular purpose. NHRA intends no other representation by such actions and specifically disclaims any liability or responsibility for any reliance by any person or entity upon such representations, including but not limited to any incidental or consequential damages that might be claimed as a result of reliance upon such representations.

As a general rule, unless optional performance equipment or a performance modification is specifically permitted by this rulebook, it is prohibited.

1.6.3 Chassis Inspection

Chassis inspection and certification is a service offered by NHRA, in express consideration of and subject at all times to the following terms and conditions, in NHRA's sole and absolute discretion. By submitting a chassis for inspection, owning or driving a vehicle which has had its chassis certified, or otherwise participating in the sport of drag racing, all participants acknowledge and agree to the following terms and conditions regarding chassis inspection and certification. Whether or not the participant or an otherwise affected party signs any documents in connection with chassis inspection or certification, the participant or otherwise affected party agrees to the terms set forth below and each is hereby put on notice of such terms and makes such agreement either by receiving this Rulebook or participating in the sport, or both. The foregoing and following terms govern all NHRA chassis inspections:

1. Participant will not operate a vehicle or allow it to be operated at a weight in excess of the "Maximum Permitted Weight" or at an elapsed time less than the "Quickest Permitted e.t." for which the chassis is certified, or otherwise not in compliance with any NHRA rule, regulation or agreement.
2. If at any time a vehicle does not comply with current NHRA Chassis Certification requirements, it will not be operated in any manner at an NHRA track, NHRA member track, or anywhere at all outside a repair garage, until required repairs have been completed and certification or recertification is obtained.
3. NHRA Chassis Certification and/or inspection (a) is undertaken for the limited purpose of allowing NHRA to satisfy itself that the chassis, at the time of inspection,

appears to comply with NHRA rules governing chassis construction, as this is a requirement for the vehicle being allowed to operate at NHRA or NHRA Member track events (including private test sessions); (b) does not constitute a certification for use at any location other than an NHRA track or NHRA member track; (c) does not constitute a warranty or guaranty of any kind, including without limitation a warranty or guarantee that the vehicle, including its chassis, is free of defects, latent or otherwise, or that the vehicle as finally constituted is or will be safe to operate; and (d) that the inspection is limited to the chassis only, as “chassis” is defined in NHRA rules.

4. **Drag racing is a dangerous sport. There is no such thing as a guaranteed safe drag race. Drag racing always carries with it the risk of serious injury or death in any number of ways. This risk will always exist no matter how much everyone connected with drag racing tries to make our sport safer. Although NHRA works to promote and enhance the safety of the sport, there are no guarantees that such safety measures will guarantee or ensure safety. The participant always has the responsibility for the participant’s own safety, and by participating in drag racing, the participant accepts all risks of injury, whether due to negligence, vehicle failure, or otherwise. If at any time a participant does not accept these risks, the participant agrees not to participate in drag racing.**
5. No liability or duty to third parties, express or implied, is undertaken or assumed by NHRA or its Member Tracks regarding any Chassis Certification or any use of a vehicle that contains a certified chassis.
6. Responsibility for the proper construction, rule compliance, and performance of a vehicle and its chassis rests with the participant at all times. If injury or death to participant or another person results from operation of the vehicle, participant releases, waives and indemnifies NHRA from and against any resulting claim against NHRA in accordance with the Administration Procedures and Appeals Section of the applicable NHRA Rulebook.

1.6.4 Retention of Vehicles and Parts

Participant hereby grants NHRA, its member tracks, and each of their agents and assigns, full and unconditional permission to collect and retain vehicles, parts of vehicles, equipment, or any other items used in conjunction with participation that are owned by or in the possession of participant or present at an event (collectively “Items”), including such Items that may be relevant incident to the investigation of an incident; the inspection or testing of such Items; or for any other purpose. NHRA may exercise this right to take and retain Items at any time when NHRA determines in its sole and absolute discretion that such actions are necessary. Participant fully releases NHRA from any liability whatsoever for loss of, damage to, or destruction of any such items. When an Item is suspected of being out of compliance with an NHRA rule, or when an Item has been involved in an incident, NHRA may in its sole and absolute discretion collect and retain such Items if NHRA believes it necessary to do so to further investigate, make a final determination, and/or preserve evidence, all in NHRA’s sole and absolute discretion. At any time that NHRA collects and retains Items, NHRA will try to safeguard such Items and return such Items when NHRA has completed its work with them, but NHRA makes no representations or warranties that the Items will not be lost, damaged, destructively tested, destroyed or otherwise affected. However, notwithstanding the foregoing sentence, if NHRA believes that an Item should be retained or destroyed,

Section 1, page 13 Administrative Procedures & Appeals

or indefinitely or permanently retained, to prevent further use of such item in competition, NHRA may so retain or destroy such item. The rights granted to NHRA in this subsection shall also apply to any NHRA member track if deemed necessary by the member track officials.

1.6.5 Protest Procedures

Contestant protests must be filed with the proper officials the day prior to eliminations (class and/or eliminator) of that category or as outlined in writing before a protest will be accepted. Protests by Event Officials may be entered at any time during the event at no charge. Inspections of protested vehicles and outcomes related thereto are not limited to the subject matter of the protest.

Protests must be accompanied by a protest fee as outlined below. Protest fee, minus Technical Department expenses, will be forfeited to the vehicle owner if the protested vehicle is found in compliance with the requirements of its class of competition. If an inspection proves a protested vehicle to be out of its proper class, fees will be refunded, less expenses, and the non-compliant entry will be subject to action as the Event Officials or Technical Department may impose, including possible disqualification, fines, suspension, and/or revocation of competition privileges.

A protested engine must be disassembled for inspection and reassembled by the vehicle owner and/or crewmembers. Failure or refusal to disassemble an engine upon demand from an Event Official will result in the removal of the vehicle from further competition and is cause for removal of the vehicle, owner, driver, and crewmembers from the racing facility and such other or further penalties as deemed appropriate by NHRA.

NHRA Lucas Oil Drag Racing Series category protest fees:

Cubic inch check (without removing head)	\$250
Bore and stroke only (with head removed)	\$350
Inspect head on engine, remove and inspect vehicle.	\$300
Remove oil pan, inspect rods and crank.	\$400
Heads, valves, carburetor, bore and stroke.	\$450
Remove oil pan, rod, piston and inspect crank.	\$500
Heads, valves, carburetor, bore and stroke plus cam.	\$600
Electronic devices	\$600
Any Professional category protest	\$1,000

Contestant protests may only be filed by a driver or registered vehicle owner competing in the same event and in the same eliminator category, as the vehicle being protested. NHRA reserves the right to reject any protest filed that it determines, in its sole and absolute discretion, is frivolous or intended to harass another competitor or to otherwise gain some unfair competitive advantage.

1.7 SUBSTANCE ABUSE POLICY

Enhancing the safety and integrity of NHRA drag racing is of paramount concern to NHRA. Substance abuse is fundamentally inconsistent with increased safety and with the integrity of a drag racing program. Accordingly, NHRA has established this Substance Abuse Policy.

This Substance Abuse Policy applies to all "Covered Individuals." "Covered Individuals" who are subject to and must comply with the Substance Abuse Policy shall include:

- (1) anyone who holds or is applying for a competition license;
- (2) all non-licensed competitors;

- (3) crew chiefs and crew members of any race team;
- (4) all team owners who are on site during an event to the extent that any such individual is participating in the preparation or operation of the race vehicle;
- (5) all NHRA officials and employees in safety sensitive positions.

Covered Individuals must submit to such testing procedures as may be conducted from time to time including without limitation those tests conducted by the Independent Drug Program Administrator (IDPA), whether on-site at an event or otherwise. Violation of the Substance Abuse Policy, or failure (whether intentional or not) or refusal to submit to testing and to honestly participate in any testing procedure, will result in disciplinary action.

Covered Individuals shall be deemed to have consented to any tests for prohibited substances and alcohol required by NHRA or its designated administrator as a condition of participation in NHRA drag racing in any capacity. Any Covered Individual who does not consent to requested testing shall be deemed to have violated this Substance Abuse Policy and shall be subject to a penalty that is at a minimum commensurate with that imposed for a Prohibited Substance First Violation.

Penalties shall be set and determined in the sole and absolute discretion of NHRA based on the totality of the circumstances and the best interests of the sport of drag racing. Following is a non-exclusive list of potential penalties which may be imposed alone or in combination: cancellation of a competition license; denial of the privilege to participate in any NHRA sanctioned or member track event; temporary or permanent suspension from competition; temporary or permanent suspension from employment; termination of employment; and other or further penalties deemed appropriate in the judgment of NHRA.

Actual or claimed lack of knowledge regarding the presence of alcohol or a Prohibited Substance in an individual's system is not an excuse and will not absolve an individual from consequences under the Substance Abuse Policy.

It is the individual's responsibility to ensure that whatever he or she ingests does not lead to a violation of the Substance Abuse Policy, regardless of intent or knowledge (for example, mouthwash, poppy seeds, etc.).

1. Testing and Administration.

- a. NHRA has selected IEPT as the Independent Drug Program Administrator ("IDPA") to implement and administer the Substance Abuse Policy.
- b. IEPT, Independent Drug Program Administrator, may be reached at 800-628-5106.
- c. If and to the extent deemed applicable by the IDPA, and if and to the extent not in conflict with NHRA's policy, United States Department of Transportation (DOT) guidelines shall be used for administration of the Substance Abuse Policy. In the event of a conflict between NHRA policy and DOT guidelines, NHRA policy shall control. For example, as to the time period allotted in which to provide an adequate sample, NHRA policy controls over DOT guidelines.
- d. All specimen testing will be conducted at a facility or facilities selected by the IDPA.
- e. All specimens once collected shall be deemed the property of NHRA.

Section 1, page 15 Administrative Procedures & Appeals

- f. All testing (including without limitation sample collection) shall be conducted according to testing methodologies that are in accordance with DOT guidelines.
- g. All testing hereunder shall be by whatever means are selected by the IDPA. The type of test to be used is determined by the IDPA. Possible types of tests may include urine, blood, breath, saliva and/or hair testing.

Determination whether there is a valid medical explanation for a laboratory result shall be made by the Medical Review Officer (“MRO”) designated by the IDPA. If contacted by the IDPA and/or MRO and/or NHRA’s Supervisor of Medical Affairs, the participant must respond within 72 hours. If requested, approval of acceptable prescription and over the counter medications will be determined by NHRA’s Supervisor of Medical Affairs.

2. Random-Selection Testing. Unannounced random tests of Covered Individuals for Prohibited Substances and alcohol will be conducted from time to time under the direction of the IDPA. Selection shall be made at random within categories of Covered Individuals, with all Covered Individuals in a category having a chance of selection. Prior selection will not remove a Covered Individual from the pool for future testing.

3. Reasonable-Suspicion Testing.

- a. Any Covered Individual may be required to submit to testing if there exists reasonable suspicion that the individual may be under the influence of a Prohibited Substance and/or alcohol before or during competition activities. There is no absolute definition of what may constitute “reasonable suspicion,” which in each case must be determined by making a judgment based on the information available at the time. Such information may include observed behavior. Once a person is identified for reasonable suspicion testing, participation in competition shall be suspended until test results are received or it is determined that the suspicion no longer exists.
- b. Any Covered Individual may be required to be tested following any incident or accident involving injury, death, or property damage, or a “near-miss” incident.

4. Noncompliance. A Covered Individual who commits any of the following acts or omissions shall be deemed to be in violation of the Substance Abuse Policy. For a first noncompliance violation, the same penalties shall apply as for a Prohibited Substance First Violation. For a second noncompliance violation, the same penalties shall apply as for a Prohibited Substance Second Violation. For a third or subsequent noncompliance the penalties for a Third Violation shall apply. Noncompliance shall include, without limitation:

- a. Refusing or failing to submit, within the required time frame stated by the IDPA, to a urine, blood, breath, hair, and/or saliva test under any provision of this policy.
 - i. **NOTE THE FOLLOWING REGARDING “SHY BLADDER”:** The IDPA provides a 24 hour window (during which the test center shall be open for a minimum of ten (10) hours) in which to provide a sample. Therefore, you will not be given time past your deadline to produce a sample and DOT policies on “shy bladder” which provide an additional 3 hour window after reporting for on-demand testing shall not apply. Be certain to allow yourself enough time before the deadline stated for your test to get to the test center and produce a sample – allowing yourself time to drink water, if necessary. Only you

can determine how much time to allow; be sure that you can get to the test center and produce a sample during the allotted time and hours when the test center is open. “Shy bladder” or other noncompliance causing you not to give a sample during the allotted time shall be deemed a refusal or failure to timely submit to the test unless medical information to the contrary has been submitted in advance to the NHRA’s Supervisor of Medical Affairs.

- b. Falsifying, altering, or otherwise tampering with any specimen provided under this Substance Abuse Policy, including without limitation using any masking agent; adulterating or diluting any sample; urine substitution; purposeful dilution of urine using pharmaceutical or other means, or attempting to do any of the foregoing, or any similar act prohibited under Department of Health and Human Services guidelines.
- c. Falsifying, altering, or otherwise tampering with any documentation related to this Substance Abuse Policy, or attempting to do any of the foregoing.
- d. Attempting to withhold or withholding required information.
- e. Refusing or failing to comply with any procedure related to Substance Abuse Policy testing, whether such noncompliance is willful, negligent, intentional, unintentional or otherwise.

5. Appeals.

- a. Except as otherwise provided herein, applicable provisions of this NHRA Rulebook regarding appeals shall apply, as provided elsewhere in this Rulebook.
- b. No stay shall be granted while appealing a suspension under this policy, whether the suspension is as a result of failure to report within the allotted time, failure to produce a sufficient sample, or otherwise.

6. Release of Information. NHRA may release, disclose, publish or otherwise disseminate the results of any substance abuse test performed under this policy, any details pertaining to the violation of this policy, the circumstances giving rise to testing, and any medical information, conclusions, and interpretations related to such test results or the performance of such tests. NHRA may share such information with law enforcement officials in NHRA’s sole and absolute discretion regardless of whether legal process has been issued. No party shall have any claim or cause of action of any kind against NHRA or anyone else with respect to any such release of information.

7. Waiver and Hold Harmless Agreement. Each participant hereby agrees to indemnify and hold harmless NHRA, its directors, officers, employees and officials, the racetrack operator and event sponsors, the Independent Drug Program Administrator (IDPA), and all other persons involved in the administration of the Substance Abuse Policy and any related items, and agrees to waive all claims against such persons for any damages, losses, or expenses of any kind that might result directly or indirectly from the Substance Abuse Policy or its implementation, including, but not limited to, actions that NHRA might take in reliance upon information produced through any testing conducted pursuant to or in connection with testing under the Substance Abuse Policy.

8. Prohibited Substances.

- a. a. “Prohibited Substances” are defined as follows: amphetamines, cocaine, marijuana (cannabis, THC),

Section 1, page 17 Administrative Procedures & Appeals

opiates (including opioids) and phencyclidine (PCP). The definition of Prohibited Substances is subject to change upon a minimum of sixty (60) days notice via a Rulebook amendment.

- b.** Covered Individuals are prohibited from consuming, possessing, ingesting, or otherwise using Prohibited Substances.
- c.** An approved prescribed Prohibited Substance that is taken other than as prescribed shall be treated as a Prohibited Substance.

NOTE: If there exists a possibility that a participant has taken a medically prescribed Prohibited Substance, it is the responsibility of the participant to inform the NHRA National Field Office so that a medical review can be undertaken to determine whether it may be deemed acceptable. NHRA's Supervisor of Medical Affairs will make final decisions concerning medical drug clearance issues. Participant must cooperate in facilitating the medical review including providing requested medical records. This list of Prohibited Substances in Section 1.7 is for the purposes of this Substance Abuse Policy only and does not limit the substances medically reviewed and allowed or disallowed for purposes of licensure and other participation in NHRA racing. SEE Section 1.6.1 above regarding licensure.

9. Alcohol.

- a.** At any time before or during competition activities, Covered Individuals are prohibited from being under the influence of alcohol (in accordance with United States Department of Transportation guidelines, which consider results of .02 and greater to be unacceptable), unless for example the Covered Individual is a racer, crew member or participating owner who has been eliminated from competition.
- b.** If the alcohol detected in a Covered Individual is under 0.040 the violation will be treated as an alcohol violation, as shown below. If the alcohol level found in a Covered Individual is 0.040 or greater, the violation will be treated the same as a Prohibited Substance violation, as shown below.
- c.** Nothing contained above or otherwise shall preclude NHRA officials from determining that a person without a measurable breath alcohol content or otherwise, is not fit to participate in an NHRA event or from taking such action as NHRA deems appropriate.

10. Consequences for Violations – Alcohol (under 0.040).

a. First Violation:

- i.** Suspension from participation in the then-current event and any NHRA or NHRA member track event for a period of thirty (30) days. "Participation" shall be defined based on the Covered Individual's role, in the discretion of NHRA. For example, a driver would not be permitted to race; a crew member could not work on a vehicle. All NHRA Member Tracks will be notified.
- ii.** \$2,500 fine, which must be paid, in full, before a request for reinstatement of the privilege of participation will be considered.

b. Second Violation:

- i.** Suspension from participation in the then-current event and any NHRA or NHRA member track event for a period of one year. All NHRA Member Tracks will be notified.
- ii.** \$5,000 fine, which must be paid, in full, before a request for reinstatement of the privilege of participation will be considered.
- iii.** Successful completion of a substance abuse program prescribed by the Medical Review Officer,

before a request for reinstatement of the privilege of participation will be considered.

c. Third Violation:

- i. Suspension from participation in the then-current event and any NHRA or NHRA member track event for a period of two (2) years. All NHRA Member Tracks will be notified.
- ii. \$10,000 fine, which must be paid, in full, before a request for reinstatement of the privilege of participation will be considered.
- iii. Successful completion of a substance abuse program prescribed by the Medical Review Officer, before a request for reinstatement of the privilege of participation will be considered.

d. Fourth Violation:

- i. Permanent suspension from NHRA and NHRA Member Track events. All Member Tracks will be notified.

11. Consequences for Violations – Prohibited Substance or Alcohol (0.040 or greater).

a. First Violation:

- i. Suspension from participation in any NHRA or NHRA Member Track event for one (1) year. All NHRA Member Tracks will be notified.
- ii. \$2,500 fine, which must be paid, in full, before a request for reinstatement of the privilege of participation will be considered.
- iii. Successful completion of a substance abuse program prescribed by the Medical Review Officer, before a request for reinstatement of the privilege of participation will be considered.

b. Second Violation:

- i. Suspension from participation in any NHRA or NHRA Member Track event for two (2) years. All NHRA Member Tracks will be notified.
- ii. \$10,000 fine, which must be paid, in full, before a request for reinstatement of the privilege of participation will be considered.
- iii. Successful completion of a substance abuse program prescribed by the Medical Review Officer, before a request for reinstatement of the privilege of participation will be considered.

c. Third Violation:

- i. Permanent suspension from participating in any NHRA or NHRA Member Track event. All NHRA Member Tracks shall be notified.

1.8 RULE ENFORCEMENT; REVIEW AND APPEALS; EXCLUSIVE MECHANISM FOR DISPUTE RESOLUTION

1.8.1 Actions Against Participants – Initial Action

If NHRA is made aware of a violation of the decisions, rules, or regulations of NHRA, NHRA shall determine whether action by NHRA is warranted. Before taking action against a participant NHRA shall, to the extent reasonably practicable, conduct an inquiry concerning the alleged violation, including the collection of relevant information. Where reasonably practicable NHRA will obtain a statement from the participant before taking action however, it shall not be necessary to receive a statement from the participant prior to initiating action against the participant. Having conducted a review of the information, NHRA shall take whatever action it shall, in its sole and absolute discretion, deem appropriate. NHRA may take immediate action against a

Section 1, page 19 Administrative Procedures & Appeals

participant if NHRA deems such action necessary (e.g. because of danger to participants, spectators, or property, or to avoid continuing violations). Such action may include but is not limited to suspension, disqualification or expulsion of the participant from an event and the event site.

Delivery of Documentation; Deadlines.

For any requests, notices and/or documentation to be provided by NHRA and/or the participant pursuant to Sections 1.8.2 through 1.8.7 below, the party and place to which such requests, notices and/or documentation are to be sent is as follows:

If to NHRA by overnight carrier:

NHRA Review/Appeals
2035 Financial Way
Glendora, CA 91741

If to NHRA by email: Appeals@NHRA.com

If to participant by mail, overnight carrier and/or email:

The address and/or email address listed on participant's Application for NHRA License and Competition Number Registration. All NHRA requests, notices and/or documentation shall be sent by overnight carrier and/or by email, in NHRA's discretion. Participant understands that if the only available address is a P.O. Box, delivery may be delayed. Participant is responsible for keeping participant's contact information up to date with NHRA.

Requests, notices and/or documentation to be provided by NHRA and/or the participant pursuant to Sections 1.8.2 through 1.8.7 shall be deemed received:

- (i) upon actual receipt as shown by proof of delivery when sent by overnight carrier; and,
- (ii) the "sent" date of the email if the email was sent prior to 5 p.m. Pacific Time on a normal business day; or, the next business day if the email was sent after 5 p.m. Pacific Time.

If business exigencies require, in NHRA's sole discretion, all deadlines specified under Sections 1.8.2 through 1.8.7 below may be extended or expedited, as deemed appropriate.

1.8.2 Statement of Action Against Participant

When action is taken against a participant a Statement of Action Against Participant will be issued in due course by the Technical Department or another appropriate NHRA department or official depending upon the nature of the alleged violation of any decision, rule or regulation, or of any sanction.

The Statement of Action Against Participant shall outline the violation. The participant will have the opportunity to respond to the Statement of Action Against Participant as described below. No action taken by NHRA shall be automatically delayed pending issuance of the Statement of Action Against Participant, however, NHRA may, in cases where immediacy is not required, provide a reasonable delay in implementation of any action or sanction so that the participant may respond (as outlined below) to the Statement of Action Against Participant before implementation of the action or sanction. Similarly, NHRA may suspend a participant pending investigation and prior to issuing a Statement of Action, in order for NHRA to have sufficient time to conduct an investigation, and where circumstances warrant immediate action in NHRA's sole discretion. Such action shall be called a "Pending Statement of Action."

1.8.2.1 Stay Pending Appeal

A participant who is eligible to and does appeal a suspension or termination of the opportunity to participate in NHRA events, or a fine, may request a stay of the action, in writing, until the review or appeal is concluded.

NHRA will respond in writing and may grant, grant with conditions, or deny the stay in its sole and absolute discretion. Points or awards obtained during a stay may be lost if the appeal is not successful or if otherwise deemed appropriate by NHRA. NHRA may revoke a stay during the pendency of the review or appeal if NHRA deems such revocation appropriate and in the best interests of NHRA or the sport of drag racing. A participant suspended, disqualified or expelled from an event will not be permitted to compete at the same event by filing an immediate request for review or appeal.

1.8.2.2 Compliance and Publication

Except during the pendency of a stay as provided in Section 1.8.2.1 above, if a participant is required to pay a fine or take any remedial action, the participant may be suspended from NHRA events and/or NHRA member track events until the fine is paid or the remedial action taken. Failure to pay fines or take remedial action in a timely fashion may result in additional action being taken by NHRA. NHRA may deduct fines owed by the participant to NHRA from any prize money owed to a participant.

NHRA at all times may publish in NHRA National Dragster and on NHRA.com, NHRARacer.com, or anywhere else, information regarding all or part of any Statement of Action Against Participant, including without limitation suspension, disqualification, expulsion and/or fines, and all related items including appeals and results of appeals. Publication may occur whether or not an appeal may be or has been filed. NHRA may share such information with law enforcement officials in NHRA's sole and absolute discretion regardless of whether legal process has been issued. Participants agree that they shall not initiate any legal action against NHRA as a result of any such publication or release of information.

1.8.3 Actions Against Participants – Participant's Response

As a first step in the appellate process regarding any appealable violation of any NHRA rule, regulation or decision, the participant may respond, in writing, which writing must be received by NHRA within **ten (10) business days** of the date of the Statement of Action Against Participant, to the Statement of Action Against Participant, explaining the participant's position and the basis therefor ("Participant's Response to Statement of Action Against Participant"). If the participant submits a Participant's Response to Statement of Action Against Participant, NHRA will evaluate it, and NHRA may, in its sole and absolute discretion, modify the action to be taken against the participant if it determines that a different action or no action is warranted. Within **ten (10) business days** of NHRA's receipt of the Participant's Response to Statement of Action Against Participant NHRA shall respond to the Participant's Response to Statement of Action Against Participant in writing, unless NHRA requires more time to conduct any investigation or analysis it deems necessary, in which case NHRA shall respond as promptly as practicable under the circumstances ("NHRA's Response to Statement of Action Against Participant"). If applicable, NHRA's Response to Statement of Action Against Participant shall advise the

Section 1, page 21 Administrative Procedures & Appeals

participant of participant's right to further appeal the decision, as set forth below.

1.8.4 Actions Against NHRA; Appeal Of NHRA Decisions

As stated in Section 1.4 above, decisions of Event Officials as described in Section 1.4 shall not be subject to review or appeal. In addition, rule changes that are technical in nature (e.g., acceptable and/or mandatory parts and/or modifications, changes made to address safety issues, changes made to equalize performance or control performance, changes made to balance competition) shall not be subject to review or appeal. Whether a rule change is technical in nature and not subject to review or appeal shall be determined in the sole and absolute judgment of NHRA.

Other than as set forth above, if an individual or other entity is directly affected by and is the subject of a decision, ruling, action, or failure to act of NHRA, including but not limited to disciplinary action, the individual or entity will be allowed to appeal the decision, ruling, action or failure to act of NHRA. Such appeals shall be undertaken as provided in this Section 1.

At any stage of appeal, the panel reviewing the decision, ruling, action or failure to act at issue shall not include individuals who were involved in the initial decision, ruling, action or failure to act or individuals who have a personal interest in the decision of the reviewing panel.

Failure to comply with any appeal procedure herein will constitute a waiver of the appeal associated with the procedure and any subsequent review or appeal. For participants who have received a Statement of Action Against Participant, the first step in the appellate process is submission of the Participant's Response to Statement of Action Against Participant, as set forth in Section 1.8.3 above. For participants appealing a decision of NHRA for which no Statement of Action Against Participant was issued, the first step in the appellate process is submission of the Notice of and Grounds for Appeal, as set forth in Section 1.8.5 below.

1.8.5 Notice Of and Grounds for Appeal

If a participant has received and responded in writing to a Statement of Action Against Participant, and wishes to appeal an appealable decision set forth in NHRA's Response to Statement of Action Against Participant, the participant must submit a written Notice of and Grounds for Appeal to NHRA so that it is received by NHRA within **ten (10) business days** of the date of NHRA's Response to Statement of Action Against Participant. The Statement of Action Against Participant will indicate the person or department of NHRA to whom the response should be directed.

For those participants appealing a decision of NHRA for which no Statement of Action Against Participant was issued (for example, a decision not involving a disciplinary or rule violation matter), the participant must submit a written Notice of and Grounds for Appeal so that it is received by NHRA within **fifteen (15) business days** of the date of the NHRA action the participant wishes to appeal.

The Notice of and Grounds for Appeal must state specifically what decision or action is being appealed and the grounds for the appeal (i.e., why the decision or action should be changed). The Notice of and Grounds for Appeal, and the Final Appeal,

if applicable, shall include a filing fee pursuant to the schedule shown below.

Notice of and Grounds for Appeal Filing Fee:

Substance Abuse	
up to but not including Final Appeal level	\$1,500
All other matters	
up to but not including Final Appeal level	\$1,000

Final Appeal Filing Fee:

Final Appeal level, Substance Abuse	\$1,500
Final Appeal level, all other matters	\$1,000

If the participant seeking review prevails in total, then the Notice of and Grounds for Appeal Filing Fee shall be refunded in total. Otherwise, there shall be no refund, and NHRA or the appellate panel may assess NHRA's and the panel's costs on appeal against an appealing participant who does not prevail, which costs must be paid before further participation in NHRA drag racing as set forth in Section 1.8.2.2.

The Notice of and Grounds for Appeal should include, to the maximum extent possible, all documents and other evidence that the participant believes substantiates the participant's position and that the participant wishes to have considered by NHRA. The Notice of and Grounds for Appeal should include the following:

- A summary of the underlying facts
- The grounds for the appeal including why the appeal is being made
- The issues to be reviewed
- The rule(s), decision(s) or action(s) involved
- The identity of any witnesses, and what each witness would be expected to say, and/or witness statements
- Any citations from the Rulebook or elsewhere that participant believes are relevant
- Other information that the participant believes relevant.

Within **twenty (20) business days** of NHRA's receipt of the Notice of and Grounds for Appeal, the appropriate NHRA representative(s) shall submit the following to the Reviewing Panel (as defined in Section 1.8.6. below), and provide a copy of the same to the appealing participant (the "Appeal Summary"):

- A summary of the underlying facts, including the background and prior proceedings (if any) and the basis for the original decision
- The issues to be reviewed
- The rule(s), decision(s) or action(s) involved
- The identity of any witnesses, and what each witness would be expected to say, and/or witness statements
- Any citations from the Rulebook or elsewhere believed to be relevant
- Other information believed relevant

1.8.6 Review Panel

Within **thirty (30) business days** of NHRA's receipt of any Notice of and Grounds for Appeal, at least three individuals designated to be members of the NHRA Review Panel (which members shall be referred to as the "Reviewing Panel") shall convene and shall review the existing record, including all evidence and materials submitted by the participant with participant's Notice of and Grounds for Appeal and all evidence and materials submitted by the appropriate NHRA representative(s) (the "Review Panel Meeting").

Section 1, page 23 Administrative Procedures & Appeals

The Reviewing Panel shall review the Notice of and Grounds for Appeal. The procedure followed by the Reviewing Panel shall be informal, shall be guided by the chair of the Reviewing Panel, and shall be conducted with the goal of promptly and fairly reaching resolution of the appeal. The Reviewing Panel may, if it deems it appropriate, arrange a meeting or conference call with the aggrieved participant and/or the other concerned parties or witnesses, and also may question witnesses, call additional witnesses, call for additional information or evidence, and/or conduct informal investigation outside the hearing. The appealing participant and other participants called on for information shall cooperate with the Reviewing Panel's requests and shall be subject to discipline for failure to cooperate. The Reviewing Panel shall not be required to follow formal or statutory rules of evidence or procedure.

The Reviewing Panel may take such action as it deems appropriate, including but not limited to increasing or decreasing penalties that have been imposed by NHRA. Within **twenty (20) business days** of the Review Panel Meeting, the Reviewing Panel shall complete its review and render its decision in writing to the appealing participant ("Review Panel Decision"). Notwithstanding the foregoing, the Reviewing Panel reserves the right to take more time to conduct any investigation or analysis it deems necessary. If such investigation will cause the Review Panel Decision to be rendered more than 30 days after the Review Panel Hearing, appellant shall be so notified.

1.8.7 Final Appeal

If the participant alleges the Review Panel Decision was in error, the participant may submit a Notice of Appeal of Review Panel Decision which must be accompanied by the applicable Final Appeal Filing Fee (provided for in Section 1.8.5 above), and must be received by NHRA within **ten (10) business days** of the date of the Review Panel Decision. This is the third stage of review for those appealing a decision where a Statement of Action Against Participant was rendered, and the second stage of review for others. This stage of review shall be the final appeal ("Final Appeal").

With the submission of Appellant's Final Appeal papers, appellant may request a waiver of the Final Appeal Filing Fee, in writing, if genuine hardship exists. Appellant must set forth the grounds for the fee waiver request, which shall be granted or denied in NHRA's sole discretion. If a fee waiver is sought, the matter shall be stayed until the fee waiver issue is resolved.

If the participant seeking the Final Appeal prevails in total, then the Final Appeal Filing Fee and the Notice of and Grounds for Appeal Filing Fee shall be refunded in total. Otherwise, there shall be no refund, and NHRA or the Final Appeal Panel may assess NHRA's and the Final Appeal Panel's costs on appeal against an appealing participant who does not prevail, which costs must be paid before further participation in NHRA drag racing as set forth in Section 1.8.2.2.

The Notice of Appeal of Review Panel Decision submitted by the appellant must contain all information on which the appellant relies for the appeal including without limitation a list of witnesses and evidence to be presented at the Final Appeal Hearing, and must state all reasons why the appellant is seeking further appeal including any errors claimed by appellant to have been made by the Review Panel.

Within **twenty (20) business days** after receipt of a Notice of

Appeal of Review Panel Decision, NHRA will appoint a three-member appellate panel and disclose the identities of such panel to the appealing participant, which shall be comprised of the following: One member of NHRA's management staff, and two members of the racing community who are not current NHRA employees ("Final Appeal Panel"). The non-NHRA employee members of the Final Appeal Panel shall meet the following requirements: (a) they shall not have been involved as a competitor of the participant in NHRA events in the given calendar year; (b) they shall not have a personal financial interest in the outcome of the Final Appeal; and (c) they shall not have an actual conflict of interest with the appealing participant.

The appealing participant shall have **five (5) business days** after the date of disclosure of the identities of the members of the Final Appeal Panel to object, if the participant chooses, to the composition of the Final Appeal Panel in writing and stating the grounds for such objection. NHRA shall have **fifteen (15) business days** from the date of NHRA's receipt of the participant's objection to the Final Appeal Panel to respond to such objection, if any, by either reconstituting the Final Appeal Panel or by rejecting the objection as untimely or unfounded. The time for conducting of the Final Appeal shall be adjusted if deemed necessary because of an objection. If any member of a reconstituted Final Appeal Panel is challenged, the same timeline shall apply.

The decision of the Final Appeal Panel shall be final and binding on all of the parties and not subject to further review.

The date of the Final Appeal Hearing shall be no more than **forty-five (45) calendar days** from the date of NHRA's receipt of the Notice of Appeal of Review Panel Decision, unless adjusted because of an objection to the Final Appeal Panel. The date, time and place for the Final Appeal Hearing shall be set by the Final Appeal Panel and shall be provided to the appealing participant with the disclosure of the Final Appeal Panel. No later than **10 days prior** to the date of the Final Appeal Hearing, NHRA shall provide the appellant and the Final Appeal Panel with a list of witnesses and evidence to be presented at the Final Appeal Hearing. Either party may supplement with further information but all efforts should be made to be complete at the party's designated time to provide information.

Prior to the Final Appeal Hearing the Final Appeal Panel will review whatever information has been provided to it by each side.

At the Final Appeal Hearing, the appealing participant must personally appear and participate and cooperate in the proceeding, and may also bring counsel who also may participate in the proceeding on behalf of the appealing participant. All such participation by the participant and counsel, and any witnesses appellant wishes to appear in person, shall be at the appealing party's sole cost and expense. NHRA shall attempt to accommodate scheduling conflicts with regard to the date and time of the Final Appeal Hearing, however, NHRA reserves the right to unilaterally set the date and time for the hearing if attempts to cooperatively schedule with appellant fail, in NHRA's sole and absolute discretion. The appealing participant and NHRA may present witnesses and documentary or other evidence. All witnesses, including the appealing participant, may be questioned by the Final Appeal Panel. The appealing participant and the NHRA representative(s) may

Section 1, page 25 Administrative Procedures & Appeals

also review the evidence presented against each side and may question adverse witnesses. The Final Appeal Hearing will proceed, in general, as follows:

- Introduction of Final Appeal Panel
- Statement by NHRA representative(s) regarding issue at hand
- NHRA witnesses and evidence
- Statement by appellant of basis for appeal
- Appellant's witnesses and evidence
- Responsive statements and evidence by each party, as necessary

The Final Appeal Hearing proceeding is informal and shall not be conducted as an adversary proceeding. The Final Appeal Panel shall determine the most effective procedures for developing the relevant facts and arriving at a conclusion. The Final Appeal Panel may question witnesses, call additional witnesses, call for additional information or evidence, and/or conduct informal investigation outside the hearing. The appealing participant and other participants called on for information shall cooperate with the Final Appeal Panel's requests and shall be subject to discipline for failure to cooperate. The Final Appeal Panel shall not be required to follow formal or statutory rules of evidence or procedure. In considering an appeal, it may be necessary for the Final Appeal Panel to call various participants to appear at the Final Appeal Hearing. Failure to comply with a request by the Panel to appear at such a hearing shall subject a participant to disciplinary action as may be determined appropriate by NHRA.

At the conclusion of the Final Appeal Hearing, the Final Appeal Panel may render a decision or may take the matter under advisement and render a decision at a later date. The decision of the Final Appeal Panel shall be rendered no later than **thirty (30) calendar days** of the Final Appeal Hearing unless additional time is required by the Final Appeal Panel to gather important and relevant information. The decision of the Final Appeal Panel shall be in writing and shall state the basis of the decision. The Final Appeal Panel may take such action as it deems appropriate, including but not limited to increasing or decreasing penalties that previously have been imposed.

The participants to the appeal agree that the determination of the Final Appeal Panel shall be final and shall not be further appealable to the NHRA or to any court, it being agreed that the dispute resolution procedures provided for herein are the exclusive remedy for the redress of grievances. However, if and to the extent that the Final Appeal Panel makes any ruling that changes the results of races, the awarding of points or the awarding of prize money, that portion of the decision must be approved or disapproved by the President of NHRA.

1.9 PUBLICITY

In consideration of being allowed to enter and by being issued credentials to an NHRA event or an event at an NHRA member track, the vehicle owner, the vehicle driver, crewmembers, extra crewmembers, advertisers, sponsors, and other holders of event credentials (the "participants") agree as follows:

- 1) All rights to use still or audio-visual images, or sounds from the events for any purpose, such as advertising, promotion, exhibition, and commercial exploitation of the event, the participants and vehicles entered in the event, and their activities at the site of the event before, during, and after the event and reasonably related to the event, are reserved to NHRA, its licensees and assigns;

- 2) Participants hereby grant NHRA, its licensees and assigns (a) full and unconditional permission to make still or motion pictures and any other type(s) of audio or audio-visual recordings of their and their vehicle's participation in the event and their activities at the site of the event before, during, and after the event and reasonably related to the event; and (b) the exclusive, worldwide and perpetual rights to use any and all recordings or portions thereof, together with their names, likenesses, and biographies, and the names, likeness, and data of, or relating to, their entered vehicles and any other information concerning their participation as collected or generated by NHRA for any purpose, in any form, on any platform, on any media by any and all means now known or hereafter developed.
- 3) Participants agree: (a) that, without the prior written consent of NHRA, they shall not take any still or motion pictures or make any audio or audio-visual recording of the event, participants therein, or activities at the site of the event for use other than personal, in-home use of the participant, or cause or permit others to do so or to use any pictures or recording or event related data compilations from the event; (b) that NHRA shall have exclusive, worldwide, and perpetual use of any pictures or recordings, or event related data compilations made or used in violation of this paragraph; and (c) that NHRA shall be irreparably harmed by the making or use of such pictures, recordings or data compilations without such permission.
- 4) Participants agree that, without the prior written consent of NHRA, they shall not offer for sale, sell, give away, or otherwise distribute at the site of the event any token, any souvenir, any product, or thing of value, or permit others to do so, and that NHRA shall be irreparably harmed by a violation of this paragraph.
- 5) Participants represent and warrant that they have obtained agreement to the above provisions of Section 1.9 from any person contributing to or participating on their team; and that they have or have obtained from any person or entity whose intellectual property, logos, brands, service marks or trademarks appear on their vehicles any and all rights, clearances and permissions necessary for NHRA, its licensees and assigns, to exploit the distribution rights to sounds and images, still or audio-visual content, of the event for any purpose, in any form, on any platform, on any media and by any and all means now known or hereafter developed. Participants shall promptly provide written evidence of such rights, clearances and permissions to NHRA upon request.
- 6) Participants acknowledge NHRA's sole right to license, publish, distribute and exploit any data or statistics compiled relating to the events or their participation in the events, whether generated by using the NHRA scoring and timing systems or otherwise, in any form, live or in a compilation, in perpetuity, however, NHRA grants permission for participants to use their own data for non-commercial purposes.

1.9.1 Pilot Team Social Media Program

AS AN EXEMPTION to the rules stated above in Section 1.9 and its subparts (1) - (6), NHRA is continuing a pilot program for social media use of certain images captured at events. The rule is below. Strict compliance required. Noncompliance subject to all available remedies including any penalty available under the Rulebook. **Please note that strict compliance with this rule is necessary to respect the sport's relationship with and commitments to FOX Sports. Violations may result in disciplinary action and/or in termination of this pilot program.**

Section 1, page 27 Administrative Procedures & Appeals

Camera use for competition purposes is governed solely by the NHRA Rulebook and the Tech Department and there are no changes to the competition camera rules. No additional competition cameras are allowed. This rule allows a person to hold a small unobtrusive camera (for example, an iPhone) outside the race vehicle. This rule prohibits any camera on or in the race vehicle or on the competitor (for example, Google glasses are prohibited).

This rule is part of a pilot project by NHRA to experiment with allowing teams to capture certain images from NHRA race venues for use to promote the team and NHRA drag racing in a positive light on social media ("Team Social Media Rule"). Because social media is an emerging area, the rights granted are subject to change, and there is no promise that the same or similar rights will be granted for the entire season, or in the future.

To use the privilege granted by this rule the following requirements apply:

Team Requirements:

- Must be a Top Fuel, Funny Car, Pro Stock, Pro Stock Motorcycle, or Pro Mod team competing in 2019 NHRA Mello Yello events (defined in this rule as "Team"). Applies at NHRA Mello Yello events only.
- No rights are granted for any other type of team or event.

Hashtags: ALL postings must include #nhra and any other hashtag(s) NHRA may require for a given weekend

On-Track Video:

- **Time and place of access:** When your driver is running, one (1) amateur videographer/photographer per lane (must have restricted area credential and Starting Line Access Pass) may take video recordings of Team's driver and crew, only from the starting line area (not from the top end, from the grandstands, from the top of the tower, or from anywhere else on track).
- **Time of posting: Video that includes any on-track action (including video taken from the starting line) may be posted only AFTER the completed program of the applicable NHRA Mello Yello event day has been telecast on the applicable FOX channel.** PM teams can post after the MYDRS show airs and do not have to wait until after the PM show airs.
- **Type of camera:** Only ONE (1) small, unobtrusive camera is allowed. The camera permitted under this Social Media Rule is separate from the one (1) camera allowed for competition purposes only under Section 9.15. Camera equipment is subject to approval by NHRA in NHRA's sole and absolute discretion. NHRA reserves the right to affix and require indicia of approval on approved equipment. No in-car cameras allowed. Contact ggray@nhra.com and kadelson@nhra.com regarding in-car cameras.
- **Credentials/Requirements:** The camera must be used by an adult, amateur videographer who has executed a Release and Waiver of Liability, has signed the Social Media Rule Agreement and Acknowledgement shown below, and has been granted and is wearing the prescribed identifying item (currently, sweatband/wristband). This rule is for Team social media only.

On-Track Still Photos: May be taken at the same time as video; may be posted at any time.

Video or Photos On-Site but Not On-Track (pits, staging lanes, etc.): Video and photos that DO NOT include on-track or racing action may be taken and posted any time, provided that all of the following conditions are met:

- No racing action is included
- Nothing is included that is being filmed as part of the FOX programs

Team Social Media Use Only: This rule is not for professional sponsors, for commercials, for film crews, for TV shows, for movies, etc. If Team or a sponsor wishes to use a professional film crew, contact dkennedy@nhra.com for consideration.

Access Limits:

- On-track racing action may be videoed or photographed only as stated above. No photos/video at top end, scales, etc.
- Team may create video of only its own drivers and crews.
- Video access shall be determined by NHRA and subject to the instruction of NHRA staff. Team shall comply with all directions of NHRA on-site staff and shall in no way impede or interfere with the conduct of the event or any part of the event and/or NHRA's recording of any part of the event. NHRA may limit or revoke video access or deny access, even after the event has commenced, in NHRA's sole and absolute discretion, at any time.

Content Limits:

- Any video and photos may be used only to illustrate in a positive manner Team's involvement in NHRA drag racing. Video and photos will include nothing detrimental to NHRA or the sport of drag racing. All video and photos will follow the philosophy of NHRA, which promotes drag racing, the role of safety in drag racing, and is a family-oriented organization.

Use of the Video and Photos Permitted for Social Media Only:

- On Team's mono-branded website
- On Team's mono-branded pages and channels on social networking sites such as Instagram, Twitter, YouTube, and Facebook.

All other uses prohibited unless approved by NHRA. To request approval for another use contact ip@nhra.com. Approval will be granted or denied in NHRA's sole and absolute discretion, and if granted will be subject to a written license agreement. Examples of prohibited uses include the following types of use:

- In any telecast or distribution over the internet other than social media.
- In any news or other media.
- In any existing or proposed television series, pilot, feature film, etc.
- Sponsor use or advertising use of any kind, use on any sponsor website or other social media channel (including co-branded or multi-branded websites and channels).
- In any commercial or advertisement
- For sale in any manner including behind a paywall or as part of any compilation sold in any manner.

Additional Use Rules

- Team may not assign, transfer or license any rights in any video or photos.

Section 1, page 29 Administrative Procedures & Appeals

- No live webcast of video or other live transmission/live streaming of any video from any event.
- Video may not be sold or monetized.
- Video may not be offered for download.
- No video clip used may be over five (5) minutes and clips may not be strung together to create an episode/program or the equivalent (e.g. like a television show, an episode of a television show or a webisode).
- Each social media posting must include #nhra and any other hashtag prescribed by NHRA for a given time.
- If it is possible to do so, each video clip must include a reference to the NHRA Mello Yello Drag Racing Series (with approved logo) on FOX (with approved logo) **with** a hyperlink to the NHRA Mello Yello TV Schedule, or if not possible to do the foregoing, then the NHRA Mello Yello Series logo and a hyperlink to the NHRA Mello Yello TV Schedule must appear on Team's website, including YouTube Channels.
- To the maximum extent possible to do so, the promotion of the NHRA Mello Yello TV Schedule must be at least as prominent on Team's website as the video usage itself. Postings of any portion of the video must include a verbal mention and/or on-screen graphic reference to the NHRA Mello Yello Drag Racing Series on FOX, including a notation to "Watch NHRA Drag Racing on FOX" or as otherwise designated by NHRA.

Approval and Takedown

NHRA has rights of approval over the actual use of video and photographs and may order the takedown of or otherwise embargo such use on any website if NHRA disapproves of the video and Team agrees to comply immediately with any request by NHRA to modify the presentation of, or take down, any video taken onsite at any event.

Additional Requirements

- If NHRA finds that Team is not using #nhra, then NHRA may require Team, within five days of NHRA's request, to furnish NHRA with a complete list of all sites/postings where any video from prior NHRA Mello Yello event is located. Project posting lists shall be sent to ip@nhra.com.
- Team grants NHRA a royalty-free license to use any video or photo captured by Team for any purpose in perpetuity by any and all means now known or hereafter developed. As soon as possible after NHRA's request, Team and any applicable individuals will supply any video or photos taken to NHRA. Team and any applicable individuals will execute any further documents necessary to memorialize this license.
- Other than as expressly set forth herein this Rule grants no license or rights to: any rights not specifically granted; marks owned by NHRA; any other participants or third party marks; any use in a manner that suggests or implies an association between any third party and the NHRA; use in connection with any fantasy gaming, "betting lines" or any form of wagering; use in any manner that would reflect negatively on NHRA; or any use that could be subject to a claim that it is defamatory, invades the right of privacy or infringes any other right of any person.
- **NOTWITHSTANDING ANY OTHER PROVISION OF THIS RULE OR THE RULEBOOK THAT MAY BE CONTRARY, IF ANY VIDEO OR PHOTO SHOT HEREUNDER CONTAINS CRASH OR OTHER RACING OR NONRACING INCIDENT MATERIAL, TEAM**

IMMEDIATELY MUST TURN OVER THE ORIGINAL AND ANY COPIES OF SUCH VIDEO AND PHOTOS TO NHRA (AND NHRA MAY CONFISCATE SUCH VIDEO AND PHOTOS IF IT IS NOT IMMEDIATELY TURNED OVER) AND TEAM MAY NOT USE SUCH VIDEO OR PHOTOS FOR ANY PURPOSE WHATSOEVER.

- Team shall bear the full responsibility for any deviation from the terms and obligations of this Social Media Rule by any person affiliated or working with Team.
- The following are among possible violations for which NHRA may take disciplinary actions:
 - Filming at the starting line area for social media without the person filming first signing the Social Media Rule Agreement and Acknowledgement.
 - Filming at the starting line area for social media without the person filming wearing the prescribed identifying item (currently sweatband/wristband).
 - Transferring the prescribed identifying item (currently sweatband/wristband) to someone who has not signed the Social Media Rule Agreement and Acknowledgement.
 - Posting video filmed at the starting line or any on-track racing action prior to the completion of the applicable television broadcast.
 - Use of more cameras than permitted at the starting line area.
 - Use of an in-car camera for social media (without explicit prior permission from NHRA Social Media and NHRA Tech).

1.10 PROPRIETARY RIGHTS

NHRA owns all rights in the “National Hot Rod Association” and “NHRA” name and marks, which are registered with the United States Patent and Trademark Office (Registration Nos. 2,220,219; 2,221,363; 1,293,428; and 1,295,041). In addition, the names National Hot Rod Association, NHRA, NHRA Mello Yello Drag Racing Series, NHRA Full Throttle Drag Racing Series, NHRA POWERade Drag Racing Series, NHRA Lucas Oil Drag Racing Series, NHRA Summit Racing Series, NHRA Championship Drag Racing, the “Wally” name and trophy, Countdown to the Championship and its variations, and other names used by NHRA, and all NHRA trademarks, service marks and trade names, as well as all associated marks, logos, designs, emblems, slogans and indicia, and the images and sounds created by and used by NHRA racing and events (collectively “NHRA Property”), are the property of NHRA or used by permission. The NHRA Property (or any colorable imitation, variation or adaptation thereof) is subject to federal and state statutory and common law trademark and copyright protections. Use of any NHRA Property without permission is prohibited. Racers and race teams are granted a non-exclusive license with no right of assignment or sublicense to use the “National Hot Rod Association” and “NHRA” marks, and Series marks as specified and required in this Rulebook, on certain items such as team uniforms and race vehicles, for race team use solely in connection with NHRA racing and events and not for use on point of sale materials or any item that is sold or resold unless pursuant to a separate written license agreement with NHRA. For guidance on permitted logo usage consult the NHRA Marketing Department. Commercial use of any NHRA Property without permission is strictly prohibited. All use of NHRA Property shall inure to the benefit of NHRA.

Section 1, page 31 Administrative Procedures & Appeals

Photo credentials governed by NHRA Photo Policy; strict compliance required; noncompliance may result in permanent denial of credential requests. Policy available from NHRA Media, (626) 914-4761. Media photography restricted to news use only. Commercial photography of any means or nature without prior written consent of NHRA prohibited. To inquire about license/access agreements or to license footage, contact ip@nhra.com.

Any commercial activity on site at an NHRA event is subject to the approval of NHRA and may be discontinued, and the participating parties made to leave the premises, if the activity is not approved or deemed not in the best interests of the sport.

1.11 CONTINGENCY AWARDS

All competitors have the opportunity to participate in NHRA's contingency programs. Programs administered from NHRA headquarters are advertised in NHRA National Dragster for all national, divisional, and E.T. championship events.

To become eligible for sponsor awards, competitors must have purchased and be prepared to show proof of the product claimed. Competitors must adhere to the specific decal-display requirements as follows:

1. Decal must be exact size and design of company's contingency decal (36-square-inch maximum).
2. One decal required for each product posting if applicable, prominently positioned on outer surfaces, clearly visible on both sides of vehicle beginning with the first round of eliminations.
3. Decals placed on vehicles once eliminations have begun will not be granted verification.
4. Decal stacking requires sponsor's permission to ensure eligibility for advertised awards (contact sponsor).
5. Decals placed on the inside of spoiler/wing spill plates are not eligible for contingency verification.
6. Decals placed on front or rear bumpers are not eligible for contingency verification.
7. Exact facsimile of sponsor's contingency decal (size, color, design) required if painted-on version is used (contact sponsor).
8. For each category posting, only one decal is permitted. Decals from competing companies for the same product will void all claims for the product category.
9. Knowingly claiming a product(s) not in use or functioning in the intended manner on the vehicle for which the claim was made is a fraudulent claim and will be denied.

Claims that do not comply with all contingency program requirements will subject the participant to disciplinary action in the sole and absolute discretion of NHRA.

Decals are available from the product manufacturer or the Tech/Registration Trailer at divisional events. Eliminator winners, runners-up, and class winners must submit to a product and decal verification in the manner required by NHRA's Technical staff in its sole and absolute discretion.

1.12 PROFESSIONAL CATEGORY OWNER GROUPS

In the interest of preserving and improving competition, reducing potential threats to racing competition, improving fan interest, reducing barriers to entry into the sport of drag racing, reducing barriers to competition, and in the best interests of the sport of drag racing, the following rules regarding the number

of teams in each professional category that may be fielded by one Owner Group have been instituted.

No Owner Group may field more than four vehicles in any professional category (currently Top Fuel, Funny Car, Pro Stock car, and Pro Stock Motorcycle). Thus, at present, an Owner Group may field up to sixteen (16) separate vehicles, but no more than four (4) in any one category.

“Owner Group” shall mean (1) the same individual or entity; (2) two or more affiliated individuals and/or entities (related by partnership, corporate affiliation, familial affiliation, marriage, or otherwise, as deemed by NHRA); (3) two or more individuals and/or entities with a financial affiliation related to competing vehicles (any financial consideration or other form of value related to the competing vehicles and any direct or indirect form or amount of common, joint or shared control, ownership, financing, management or revenue sharing); or (4) any other relationship or affiliation deemed by NHRA to constitute group ownership or control of vehicles. Sales of vehicles, parts, and the like at fair market rates shall not be deemed to create an “Owner Group” affiliation.

NHRA’s determination that various vehicles are controlled by the same Owner Group shall be made in NHRA’s sole and absolute discretion. Any participant must cooperate with NHRA in supplying the information needed by NHRA to determine whether various teams/vehicles are owned or controlled by an Owner Group. Penalties for failure to comply with such a request for information, for attempting to camouflage ownership, or for otherwise attempting to circumvent or circumventing or not complying with this rule shall be imposed by NHRA in NHRA’s sole and absolute discretion and may include, without limitation, reduction of points awarded to teams in the Owner Group. As with all NHRA rules, this rule is subject to change in NHRA’s sole and absolute discretion.

1.13 ENVIRONMENTAL MANAGEMENT RESPONSIBILITIES FOR ALL PARTICIPANTS

NHRA is committed to protecting the environment at racing venues. Toward this end, the NHRA has developed the following rules regarding the use, possession and disposal of regulated waste(s) at NHRA events and/or facilities, effective at all National Events beginning with the 2010 Gainesville race:

1. Compliance with Mandatory Training. Each Participant must participate (in person or online) in a mandatory training session regarding environmental issues as they relate to racing. Each owner and team member must sign a certification of training and acknowledgement of the rules. All team members and those working on behalf of the team are subject to this rule and will be bound by any team representative’s certification of agreement to comply with the rule. Training is available online on the National Event Registration Web site and will be available in printed form onsite at NHRA Registration Trailer. In addition there will be an on-site contact for questions will be available at the Gatornationals.

2. No Halogenated or Chlorinated Brake Cleaners. No Halogenated and/or Chlorinated brake cleaning products may be used at NHRA events or facilities.

3. Participant Responsibility. The responsibility for compliance with Federal, State or local regulations governing

Section 1, page 33 Administrative Procedures & Appeals

solid, recyclable and/or hazardous wastes (known as “Waste Regulations”) belongs to the Participant, not NHRA or any track. Each Participant must properly store, use, dispose of and account for any and all materials in the Participant’s possession that may be subject to Waste Regulations and be in compliance with all such Waste Regulations at all times, and must comply with any rules or procedures of the host track or its designated waste handling company. Should any Participant be found to be out of compliance, the Participant shall be responsible for any and all penalties, fines, costs and clean up necessary for compliance.

4. Enforcement. NHRA will work with the applicable governmental entities, agencies and track to monitor violations of any applicable environmental regulations. Non-compliance with an NHRA environmental standard or a governmental standard threatens the integrity of the sport of drag racing and the ability of NHRA and member tracks to provide venues for racing. Therefore, any violations will be dealt with accordingly. NHRA penalties are separate and apart from any civil or criminal penalties or other action that may be taken by any governmental entity or law enforcement agency.

5. Zero Tolerance. There shall be a “zero tolerance” policy with regard to the improper use or disposal of any solid or hazardous waste that causes pollution so as to harm or injure human health or welfare, the environment, animals, plants, aquatic life or property, as defined by any agency exercising jurisdiction over such activities.

6. Penalties. Penalties for failure to comply with any portion of this policy will be assessed by NHRA in NHRA’s sole and absolute discretion, and taking into account the circumstances surrounding the violation. A minimum \$1,000 fine will be imposed for any violation. Penalties may also include disqualification, loss of points, suspension, or such other penalties as deemed appropriate by NHRA. Repeat violations may result in permanent suspension from NHRA Championship Drag Racing events and NHRA member track events.

Race Procedures Index

Proper Use of Safety Equipment	1
NHRA Competition Numbers	1
Burnouts	2
Staging	2
Qualifying	3
Driver and/or Vehicle Changes	3
Replacement Driver	4
Replacement Vehicles	4
Class Changes	4
Ladders	5
Handicapping	5
Dialing Under the Index	5
Competition Index Control (CIC)	5
Breakout Rules	7
Single Runs	7
Lane Choice	7
Alternates	7
Alternates, NHRA Mello Yello Drag Racing Series . . .	8
Alternates, NHRA Lucas Oil Drag Racing Series and E3 Spark Plugs NHRA Pro Mod Drag Racing Series presented by J&A Service	8
Disqualifications	8
Oil-down Penalties	9
National Record Procedures	10
Weighing of Vehicle/Fuel Check	11

SECTION 2 RACE PROCEDURES

PROPER USE OF SAFETY EQUIPMENT

Seat belts must be worn and adjusted in such a manner that the driver's torso and head cannot extend outside the parameters of the roll cage. The loosening and removal of seat belts, helmets, gloves, window nets, lifting of helmet shield, and removal of all other safety equipment is prohibited from the time the vehicle leaves the ready line until the vehicle is on the return road. Fire bottle safety pins/clips must be removed from fire bottle controls from the time the vehicle leaves the ready line until the vehicle is on the return road. Fresh air systems must be on and providing airflow to the driver's helmet from the time the vehicle leaves the ready line until the vehicle is on the return road. Violators will be subject to disciplinary action in the sole and absolute discretion of NHRA.

NHRA COMPETITION NUMBERS

All contestants are required to display a permanent driver number at all NHRA Mello Yello Drag Racing Series national events, NHRA Lucas Oil Drag Racing Series divisional events, NHRA National Open events, and divisional NHRA Summit Racing Series Finals. Numbers are issued to drivers only and are available from NHRA. Racers must have a separate number for each eliminator category. In recognition of their previous-year performance, all NHRA Mello Yello Drag Racing Series world champions, top 10 Mello Yello points earners, and all NHRA Lucas Oil Drag Racing Series champions will receive special numbers for the current season. Special two-digit "lifetime"

permanent numbers are available for Mello Yello-category contestants only; contact the NHRA Competition Department for fees and other details.

BURNOUTS

All pre-race burnouts are restricted to designated areas, using water only. If a contestant's vehicle should break on a burnout and cannot back up or be pushed back, it is not permitted to turn on the track and drive back to the starting line. Crossing the centerline during a burnout is not a disqualification. Fire burnouts are strictly prohibited. No person is permitted to hold or touch cars during burnouts.

At national events, Top Fuel, Funny Car, Pro Stock, Pro Stock Motorcycle, Pro Mod, Top Fuel Harley, Top Alcohol Dragster, Top Alcohol Funny Car, Comp, Super Comp, Top Dragster, and Top Sportsman drivers are allowed one burnout across the starting line under power. Length and time duration must be reasonable and in concert with the opponent's procedures. Super Stock, Stock, Super Gas, and Super Street drivers may not cross the starting line on any burnout; stationary burnout limit is five seconds. Divisional event burnout limitations are at the discretion of the event director.

STAGING

Once a vehicle reaches the front of the staging lanes for a run, it must be prepared to fire and race. Vehicles in Top Fuel, Funny Car, Top Alcohol Dragster, and Top Alcohol Funny Car classes, once started and having moved into the burnout area, may not restart engines.

To be a legitimate race winner, a contestant's vehicle must self-start and self-stage. This rule also applies to single runs. Push-starting or push-staging any vehicle is prohibited. Staging must be done under the vehicle's own engine power. Pro Stock Motorcycles are allowed to restart as necessary; however, this must be done in a time frame that permits the contestant to complete the run with the designated opponent. If the opponent has been sent on a single run, the bike losing fire may not restart and the run is forfeited.

In any category where dial-ins are displayed on a scoreboard or dial-in board, during eliminations, the racer accepts the dial-in displayed once he/she has pre-staged; no reruns will be granted due to incorrect dial-ins after pre-staging.

The application or use of any device, mechanical or electronic, that permits the driver to ascertain the position of his or her vehicle in relation to the starting line is prohibited. Only visual observation of track equipment may be used to ascertain the vehicle's position.

The practice referred to as "deep staging" is prohibited in the Super Stock, Stock, Super Comp, Super Gas, and Super Street categories (permitted in all other categories). Both pre-stage and stage lights must be activated to constitute a legal start in those categories. In a dual deep-stage situation, both competitors will be disqualified, except in the final round of competition, in which case the two finalists will be rerun. When staging in Super Stock, Stock, Top Dragster, Top Sportsman, Super Comp, Super Gas, Super Street, or Competition Eliminator categories, both contestants must activate their pre-stage lights before either may advance into the stage beams. In the heads-up categories (TF, FC, PS, PSM, PM, TAD, TAFC, SC, SG, SST), if both drivers of a race leave the line before the start system is activated, the driver leaving first is disqualified — if unable to determine who left first, both drivers are disqualified. Any e.t.s posted would be void for lane choice or other considerations. **THE FINAL STAGING MOTION, USING APPLIED POWER, MUST BE IN A FORWARD MOTION, GOING FROM PRE-STAGE TO STAGE POSITION** (this procedure does not apply to motorcycles).

A reasonable amount of time will be permitted for drivers to stage. The time limit will be determined at the sole and absolute discretion of the official starter. Failure to stage upon the starter's instructions is possible grounds for disqualification. After proper staging and receiving the starter's signal to go, restaging for a second time is prohibited. Any driver leaving the starting line before the start system is activated, including a driver on a single run, will have his or her time disqualified for the run.

QUALIFYING

To constitute an official qualifying attempt, all vehicles must self-start and self-stage. At NHRA Mello Yello Drag Racing Series, Lucas Oil Drag Racing Series, NHRA National Open, and Summit Racing Series Finals events, a contestant cannot drive more than one vehicle in the same category at the same event, nor can one vehicle be used for multiple entries. Multiple driver restriction for E.T. classes, at NHRA member track events, may vary based on specific member track E.T. regulations. Racers are advised to contact the respective division office or member track for regulations within that geographic area. Vehicles must remain in the same category entered, with one registered driver for the duration of the event.

All qualifiers in Top Fuel, Funny Car, Pro Stock, Pro Stock Motorcycle, Pro Mod, Top Fuel Harley, Top Alcohol Dragster, Top Alcohol Funny Car, Comp, Super Stock, Stock, Top Dragster, and Top Sportsman must have a qualifying attempt to be placed into eliminator competition. If conditions should curtail scheduled qualifying attempts and the field is under the specified field size in Comp, Super Stock, Stock, Top Dragster, or Top Sportsman categories, the event director has the option of placing non-qualified entrants into the field.

On a qualifying run, if a contestant properly starts, stages, and receives the starter's signal but breaks to the point the run is not completed, a time of 28 seconds is issued and it is considered a valid qualifying run. Should more than one contestant break prior to completing a run and an insufficient number of open spots are available on the ladder, the order of insertion onto the ladder would begin with the contestant who made the qualifying attempt first.

In the event of identical qualifying elapsed times in the Mello Yello and Top Alcohol Dragster/Funny Car categories, the driver with the faster top speed, recorded on the qualifying runs in question, will be awarded the better qualifying position.

If weather conditions or other event delays should disrupt the posted lane rotation for qualifying runs, the event director has the option of reassigning lanes as necessary for remaining runs. Every effort will be made to see that qualifying contestants have the opportunity to run in each lane.

DRIVER AND/OR VEHICLE CHANGES

Under certain circumstances, in the sole and absolute discretion of the event director, the event director has the option of permitting a driver change or a vehicle change. The spirit of the driver change policy is to accommodate those rare cases where a driver experiences an unforeseen circumstance preventing him/her from continuing competition in an event (i.e., medical problem, personal tragedy, etc.). **Driver changes in the Sportsman categories at national events are NOT permitted.** Only one action per event is permitted - a driver change plus a vehicle change is NOT permitted. Changes may be considered only under the following conditions:

REPLACEMENT DRIVER

1. The original entered driver must have been in attendance and successfully passed tech inspection at the event.
2. Replacement driver must have proper credentials and sufficient grading.
3. The original driver is withdrawn from competition and cannot be reinstated.

***TAD, TAFC, Comp, SS, Stock, SC, SG, and SST categories (non-national events only):**

- If change is made prior to the close of registration the day prior to any scheduled activity for subject category, original entered driver will NOT be charged with event or receive points. - If change is made the day of scheduled running of his/her category, event will be charged against the withdrawn driver's annual quota of scored events, with 10 points being awarded.

- Replacement driver will receive full earned points.

***TF, FC, PS, PSM, PM, TFH categories:**

- The withdrawn driver will NOT receive any points.

4. All previous event times are voided for the vehicles and drivers involved.
5. Changes must be made and driver must re-qualify during the normal schedule, as posted, for the event. No changes are permitted after qualifying has been completed.
6. Teams are limited to one replacement driver action per event.
7. Replacement driver must drive the vehicle originally entered as described on the entry form.
8. Any event prize monies will be paid to payee as designated on original entry.

REPLACEMENT VEHICLES

1. The original vehicle is withdrawn from competition and cannot be reinstated.
2. Replacement vehicle cannot have been utilized by any other contestant at the same event.
3. Replacement vehicle must be fully certified and must pass technical inspection prior to continuation of competition.
4. Driver must stay within original eliminator category and class entered.

5. TAD, TAFC, Comp, SS, Stock, TD, and TS categories:

All previous event times are voided for the vehicles and drivers involved. Changes must be made and driver must re-qualify during the normal schedule, as posted for the event. No changes are permitted after qualifying has been completed. No changes are permitted after qualifying has been completed. **SC, SG, and SST categories:** All previous event times are voided for the vehicles and drivers involved. Changes must be made prior to first round of eliminations. No changes are permitted after first round of eliminations has been completed.

TF, FC, PS, PSM, PM, TFH categories: Driver retains qualifying times and standings as posted while driving the original entered vehicle. Replacement vehicles may be utilized at any time during an event (including eliminations)

6. Checkout runs for replacement vehicles are not available.
7. Teams are limited to one replacement vehicle action per event.

CLASS CHANGES

After a contestant's vehicle has been inspected and classified, no changes of class are permitted. For example, a contestant in Comp Eliminator could change engines during an event; however, he/she cannot move from one Comp class to another. Mechanical changes permitted provided vehicle legitimately remains in the class in which it was originally registered.

If an event is disrupted and rescheduled due to weather or other conditions, the following options are permitted: Super Stock and Stock contestants may reregister in a different class but must remain within their eliminator category. Super Comp, Super Gas, and Super Street contestants must remain in the category originally entered. This policy only applies if eliminations were not in progress.

LADDERS

Category pairings are based upon established NHRA "ladder" charts. Qualifying elapsed times determine ladder positions (16-car Mello Yello, Top Alcohol Funny Car/Dragster fields at national events, example: 1 vs. 16; 2 vs. 15; 3 vs. 14; 4 vs. 13; 5 vs. 12; 6 vs. 11; 7 vs. 10; and 8 vs. 9). Once established, pairings are not changed unless NHRA determines there is adequate justification for a change. In situations where fields are not filled, such as 14 cars entering for a 16-car field, a 14-car ladder will be used, not a 16-car ladder.

Qualified Sportsman fields use a modified ladder in which the top half of the field is matched to the lower half (1 vs. 17, 2 vs. 18, 3 vs. 19, etc. in a 32-car field). Super Comp, Super Gas, and Super Street use random pairings for the initial round of competition, with those first-round winning times determining subsequent round pairings.

HANDICAPPING

Comp, Super Stock, and Stock handicapping is based upon the NHRA index system. Handicap margins can be determined simply by comparing individual class index elapsed-time factors (as listed on NHRARacer.com).

DIALING UNDER THE INDEX

Contestants in Super Stock and Stock have the option of dialing under their class' assigned index. It is the responsibility of each contestant to place the selected time on the windshield and tower-side window prior to each round of competition. Dial-unders may be changed between rounds, including a rerun situation. All contestants not choosing to dial under will automatically be handicapped on the basis of their assigned class index. In cases where two cars of the same class are paired, the race is conducted on a heads-up basis, regardless of any dialing-under considerations, and breakout rulings do not apply.

COMPETITION INDEX CONTROL (CIC)

In an attempt to control runaway index situations in Competition eliminator, CIC will be in effect during eliminations at all NHRA Mello Yello Drag Racing Series national and NHRA Lucas Oil Drag Racing Series events. (Any other event will not carry permanent CIC adjustments.) Once a competitor adjusts a class or personal index in two classes through a permanent CIC, that competitor is restricted to competition in the affected classes only and will not be allowed to compete in any other Comp class for the remainder of the current season. If a competitor adjusts a single class or personal index or does not adjust an index permanently, he/she will be allowed to compete in any Comp class. Any contestant running $-.50$ or quicker during eliminations (not during qualifying or time trials) will have his or her index adjusted by the amount he or she exceeds $-.50$ for the following round of eliminations.

In cases where two cars of the same class are paired, the race is conducted on a heads-up basis, regardless of any CIC considerations.

Class Index

Any contestant who runs $-.710$ or greater in official eliminations

will cause his or her respective class index to be permanently adjusted by an increment equal to the second decimal of the infraction immediately following the event. The CIC adjustment will be conducted with one plateau and will follow the chart below:

Runs Under	Adjustment	Runs Under	Adjustment
.70	.00	.76	.06
.71	.01	.77	.07
.72	.02	.78	.08
.73	.03	.79	.09
.74	.04	.80-above	.10 maximum
.75	.05		

Examples: The adjustments for runs .710 through .80 under will continue to increase in .01-second increments with a maximum increase of .1-second per event.

At events conducted at altitude-corrected tracks, all relevant altitude factoring will be used for event CICs and permanent CICs. Example: A contestant runs .720 under the altitude-corrected index. This will cause a permanent CIC adjustment to the sea-level index of .02.

Any contestant who posts an elapsed time during eliminations that would generate a permanent class index CIC adjustment (.710 or more under index), then fails to pass certification for the run (weight, fuel, etc., including "driving by" the scales) will automatically be disqualified from the event. The event will be charged against the competitor's annual quota of scored events with zero points.

Note: Event CIC will be a straight 1-to-1 index reduction. Permanent personal or permanent class index reductions following an event will be no more than .1-second.

EIGHTH-MILE EVENTS: For eighth-mile events, the above policy will be adjusted as follows: Any contestant running -.35 or quicker during eliminations (not during qualifying or time trials) will have his or her index adjusted by the amount he or she exceeds -.35 for the following round of eliminations.

For additional information on mineshaft conditions and year-end CIC reviews, visit NHRARacer.com.

Personal Index

Any contestant who runs -.610 or greater in official eliminations will cause his or her respective personal index to be permanently adjusted by an increment equal to the second decimal of the infraction immediately following the event. The CIC adjustment will be conducted with one plateau and will follow the chart below:

Runs Under	Adjustment	Runs Under	Adjustment
.60	.00	.66	.06
.61	.01	.67	.07
.62	.02	.68	.08
.63	.03	.69	.09
.64	.04	.70-greater	.10 maximum
.65	.05		

Examples: The adjustments for runs .610 through .70 under will continue to increase in .01-second increments with a maximum increase of .1-second. At events conducted at altitude-corrected tracks, all relevant altitude factoring will be used for event CICs and permanent CICs. Example: A contestant runs .620 under the altitude-corrected index. This

will cause a permanent CIC adjustment to the sea-level index of .02.

Any contestant who posts an elapsed time during eliminations that would generate a permanent personal index CIC adjustment (.610 or more under index), then fails to pass certification for the run (weight, fuel, etc., including "driving by" the scales) will automatically be disqualified from the event. The event will be charged against the competitor's annual quota of scored events with zero points.

BREAKOUT RULES

In Super Stock, Stock, Super Comp, Super Gas, Super Street, Top Dragster, and Top Sportsman categories, the breakout rules are enforced at national, divisional, and National Open events as follows: Contestants who race below the posted index or category standard during eliminations are disqualified, with the following exceptions:

1. when an opponent foul starts or crosses a boundary line
2. on a single run
3. when both drivers run under their index, the driver who is the least under is the winner
4. when two cars of the same class race (doesn't apply to Super categories)
5. if two contestants run under by the same margin (with elapsed times extended to a thousandth of a second), the driver crossing the finish line first is the winner

SINGLE RUNS

In situations where a driver is making a single run, he or she is considered the winner once he or she stages and receives the start signal or is declared the winner by the official starter. If a competitor crosses the boundary line on a single run, the elapsed time is voided for lane-choice determination.

LANE CHOICE

In the Top Fuel, Funny Car, Pro Stock, Pro Stock Motorcycle, Top Alcohol Dragster/Funny Car, Pro Mod, Top Sportsman, and Top Dragster categories, lane choice is determined by elapsed times. The racer with the better qualifying e.t. gets first-round lane choice, and in subsequent rounds, lane choice goes to the racer with the lowest e.t. in the previous round.

In Comp, lane choice is determined by elapsed time. The driver with the better qualifying position gets first-round lane choice, and in subsequent rounds, the lane choice goes to the driver with the lowest elapsed time (in relation to his or her index) from the previous round (e.t. is calculated off the actual index, not the contestant's CIC corrected Index). If there is a tie to the thousandth, speed is not the determining factor - the first contestant posting the time will take precedence.

In all other categories, competing drivers are to determine lane choice by a coin flip or a random-draw lane assignment.

ALTERNATES

Once qualifying has concluded and a ladder has been established, pairings will not be changed. However, should a qualified vehicle and racer be unable to make the first round of eliminations, an alternate will be inserted in his or her place. Under normal conditions, all first-round points and cash awards will remain with the qualified racer. Alternates will not be eligible for any round points, regardless of how far they advance past round one, and the cash award paid will be less the amount paid to the original qualifier.

If an event is postponed due to weather or other conditions prior

to the start of eliminations for that category, it is necessary that the qualified vehicle and racer be in attendance and participate at the rescheduled date to be eligible for all points and awards based on eliminator competition. Awards based solely on qualifying remain with the original qualifier (excluding national event position points for Top Alcohol Dragster, Top Alcohol Funny Car, and Comp). It is important to note that points and awards are based on a round-loss basis, not simply on qualifying.

If an alternate racer is inserted into a rescheduled event for a non-returning qualifier, the alternate will receive full round points and cash awards.

ALTERNATES, NHRA MELLO YELLO DRAG RACING SERIES

Final eliminator fields for each of the four Mello Yello categories — Top Fuel, Funny Car, Pro Stock, and Pro Stock Motorcycle — will consist of only the 16 low e.t. qualifiers. Alternates will not be eligible to enter the field under any circumstances.

If a qualified contestant should be disqualified prior to the start of eliminations, the next racer in sequence would be inserted in order and would assume full qualifier status, including points and awards. Once the final pairings have been established, the ladder will not be changed. If a qualified contestant cannot appear for round one of eliminations, the scheduled opponent, regardless of qualified position, will receive a bye run.

If an event is rescheduled due to weather or other conditions, it is mandatory that qualifiers be in attendance to earn points and monetary awards. Alternates will NOT be eligible to enter the field at a rescheduled event.

The NHRA policy concerning the use of alternates in Mello Yello categories at national events does not apply to the following specialty races: NHRA Traxxas Nitro Shootout, K&N Horsepower Challenge, and Mickey Thompson Tires Pro Bike Battle.

In these specialty competitions, the highest-rated eligible alternate may enter in a field ONLY if one of the original qualifiers is unable to race and/or is not competing in the same class at the host national event.

ALTERNATES, NHRA LUCAS OIL DRAG RACING SERIES AND E3 SPARK PLUGS NHRA PRO MOD DRAG RACING SERIES PRESENTED BY J&A SERVICE

In an attempt to always reward the quicker of the qualifiers, the insertion of alternates is as follows: The first alternate will be positioned to race the slower of the opponents made available by original qualifier's failure to appear in round one, the second alternate will race the next-slowest car, and so on, until either the ladder is complete or all alternates have been assigned ladder positions. The "break" rule for substitution of once-eliminated cars for cars that subsequently can't compete is not used at national or divisional events.

DISQUALIFICATIONS

Notwithstanding any other provision of this Rulebook, participation in any program conducted by or in conjunction with NHRA is conditioned upon being in good standing with NHRA, as determined in NHRA's sole and absolute discretion. Any person found guilty of drug-related offenses or other serious offenses is subject to such disciplinary action as NHRA shall determine appropriate in its sole and absolute discretion,

including, but not limited to, immediate expulsion from NHRA and a termination of good standing. Such person may be immediately excluded from all NHRA programs and may not be eligible for titles, prize money, or other awards that have not already been bestowed, as shall be determined by NHRA. Further, any annual awards that might be granted may be made contingent upon maintaining good standing with NHRA through the year following the annual award, if so determined by NHRA. Further still, any person who shall be facing prosecution for a drug-related offense or other serious offense may be granted such awards on a contingent basis and may not be eligible for annual awards of prize money unless and until he or she shall have been found not guilty of such offenses during the year following the award of such prizes if so determined by NHRA.

One of the rarities at an NHRA event is the situation in which two cars are disqualified during the same elimination race. In most cases, both offending contestants are disqualified. Those situations include both drivers crossing the boundary lines, both drivers deep staging (Super Stock, Stock, Super Comp, Super Gas, Super Street), or both drivers leaving the line before the start system is activated (handicap categories only). The object of the final round is to determine a winner and a runner-up, with the Event Director having full responsibility in cases involving dual disqualifications. As an example, in the final round, the contestant crossing the boundary line first will be disqualified.

Should a driver receive a red-light foul start and the opposing driver cross the lane boundary line, the latter infraction would prevail and the driver committing the foul start would be reinstated. In determining lane-boundary-crossing violations, it is considered a disqualification when any portion of a tire completely crosses the painted-line surface. In cases where both opponents cross the centerline or outside line, both drivers will be disqualified. In situations where multiple boundary lines are utilized, the line directly adjacent to the competitor's racing lane will be used for reference. Anytime it has been judged that excessive braking has resulted in loss of control that results in contact with the guardwall and/or light fixtures or crossing the center boundary lines, INCLUDING PAST THE FINISH LINE, the contestant will be disqualified. Contact with guardwall, barriers, or any other track fixture (rubber cones, when used, are considered visual aids, not fixtures) is grounds for disqualification and/or other actions. Intentional crossing of boundary lines to leave track or avoid depositing debris on track is not grounds for disqualification.

Any driver and/or pit crewmember found to be under the influence of alcoholic beverages or drugs, regardless of amount, will be ejected from the event. Such a condition is cause for suspension, fine, and/or revocation of competition privileges.

OILDOWN PENALTIES

Oildowns and, more important, downtime associated with cleanups affect everyone at an NHRA Mello Yello Drag Racing Series event, including spectators, competitors, sponsors, and television viewers. With curfews and schedules, oildowns in both Mello Yello and Sportsman categories have caused in some cases cancellation of qualifying sessions, early start times, and very late conclusions to the respective sessions.

In an effort to eliminate downtime due to oil cleanup, penalties may be in effect at the NHRA Mello Yello national events. Penalties may be imposed on teams depositing oil on the racetrack surface during any qualifying and/or elimination round.

Refer to NHRARacer.com for the most current oildown policy.

Any contestant demonstrating a flagrant disregard or repeated violation will be subject to disciplinary action as deemed appropriate by NHRA in its sole and absolute discretion. Such action may involve monetary fines, denial to participate at national events, and/or suspension of competition privileges.

The Event Director's decision is final in determining oildown violations. There is no provision for review of decisions of the Event Director, his designee, or other NHRA event officials at racing events. The reason for this is to ensure that there can be finality with regard to the events that are run. To provide for an appeal of all actions or inactions of the Event Director would result in a delay in the determination of literally every NHRA national event. Such interminable delays are unacceptable to the sport, the participants, and the spectators.

NATIONAL RECORD PROCEDURES

The standard of excellence of performance in drag racing is the NHRA national record. These records are established under controlled conditions at authorized record events throughout the season. NHRA's official national records program is conducted at each of the NHRA Mello Yello Drag Racing Series national events (Mello Yello, Top Alcohol Dragster/Funny Car, and Pro Mod categories only), NHRA Lucas Oil Drag Racing Series divisional events, official NHRA National Opens, and at other specifically designated national record events.

National Record Procedures at National Events

NHRA teams participating in the NHRA Mello Yello Series, J&A Service Pro Mod Series, and the Lucas Oil Series alcohol categories who post performances for elapsed time and speed that are quicker or faster than the existing national records at any time during a national event will be eligible for the national record. The driver holding the record at the conclusion of the race will be credited with the record. Elapsed-time records will be recorded and listed to the thousandth of a second. Speed records will be to the hundredth of a mile per hour. If two contestants tie for the elapsed-time record to the thousandth of a second at the same event, the tiebreaker will be the fastest mile-per-hour reading for the run that established the record. In the event a tie still exists, the contestant accomplishing the record run earlier in the event will be awarded the record. If the record is tied at a later race, the record will stay with the driver who set it first. Similarly, if two contestants tie for the speed mark, the tiebreaker will be the quickest elapsed time on the run that established the new national record. No points will be awarded for elapsed time or speed records at national events. Mello Yello, Top Alcohol Dragster/Funny Car, and Pro Mod contestants may set speed marks independent of elapsed-time records.

Each record run is made under close observation of starting procedures, running, finish, and timing. Each vehicle is thoroughly inspected to determine its compliance with class requirements, including weight, engine displacement, mechanical limitations, and fuel checks where necessary.

National Record Procedures at Non-National Events

Each record run is made under close observation of starting procedures, running, finish, and timing. Each vehicle is thoroughly inspected to determine its compliance with class requirements, including weight, engine displacement, mechanical limitations, and fuel checks where necessary. A

backup performance of within 1 percent of the new mark is required at the same event, except for the alcohol categories. In the event that two runs exceed the existing record but are not within 1 percent of each other, the quicker time or faster speed will be acceptable as the backup for the slower time, which will stand as the new record.

Elapsed-time records will be recorded to the hundredth of a second. Speed records will be to the hundredth of a mile per hour. If two contestants tie for the elapsed-time record to the thousandth of a second at the same event, the tiebreaker will be the fastest mile-per-hour reading for the run that established the record. In the event a tie still exists, the contestant accomplishing the record run earlier in the event will be awarded the record. If the record is tied at a later race, the record will stay with the driver who set it first. Similarly, if two contestants tie for the speed mark, the tiebreaker will be the quickest elapsed time on the run that established the new national record. Top Alcohol Dragster/Funny Car contestants may set speed marks independent of elapsed-time records; records may be set until the driver is eliminated from further competition; previous runs acceptable as 1 percent record backup. Super Stock and Stock contestants may use previous runs as acceptable 1 percent backup. Speed records in Comp, Super Stock, and Stock can be established only in conjunction with elapsed-time records. Comp records may be set in the first round of eliminations, using a previous qualifying run from the same event as a backup if within the necessary 1 percent of the record time. Super Stock and Stock contestants may not set or back up records during any rounds of competition. Comp, Super Stock, and Stock records will retire automatically after two years, on the last day of the previous month in which the record was set. With the exception of National Opens, eighth-mile records may be set at eighth-mile events only.

A contestant cannot set records with one vehicle, then compete in eliminations with another vehicle. Only the driver holding the record at the conclusion of the event will be credited with the record. A driver setting then losing a record at the same event will not receive credit for establishing a record.

WEIGHING OF VEHICLE/FUEL CHECK

Under no circumstances may a competitor reject scaling his or her vehicle or fuel check. Any competitor who runs quicker than any of his or her previous runs during the event in Top Fuel, Funny Car, Pro Stock, Pro Stock Motorcycle, Top Alcohol Dragster, Top Alcohol Funny Car, Pro Mod, Comp, Super Stock, or Stock and fails to report to post-run inspection (scales or fuel check) will be disqualified from the event. The event will be charged against the competitor's points events with a zero (0) point counting toward the driver's claimed races.

Points and Related Programs Index

NHRA Mello Yello Drag Racing Series 1
 NHRA Mello Yello Countdown to the Championship . . . 2
 NHRA Lucas Oil National Championship 2
 NHRA Lucas Oil Regional and Divisional
 Championship 3
 Top Dragster and Top Sportsman National
 Championship 3
 NHRA Lucas Oil Drag Racing Series Points 3
 E3 Spark Plugs NHRA Pro Mod Drag Racing Series
 presented by J&A Service 4
 Professional Specialty Series 4
 Specialty Series – General 5
 JEGS Allstars. 6
 Manufacturers Cup 7
 Points – General 7
 Logo Placement 8
 Mello Yello – Vehicle 8
 Mello Yello – Driver/Rider Uniform 8
 Sportsman – Vehicle 8
 Pro Mod – Vehicle 9
 Pro Mod – Driver Uniform 9

**SECTION 3
 POINTS AND RELATED PROGRAMS**

NHRA MELLO YELLO DRAG RACING SERIES

The 2019 NHRA Mello Yello Drag Racing Series begins with the Lucas Oil NHRA Winternationals presented by Protect the Harvest and concludes with the Auto Club NHRA Finals.

National Events: The premier series of NHRA races features the Mello Yello categories of racing and the NHRA Lucas Oil Drag Racing Series classes. The national event tour begins each February in Pomona, Calif., and visits multiple sites throughout the United States, winding its way back to Pomona in November.

Contestants in each of the Mello Yello racing categories compete for the NHRA Mello Yello Drag Racing Series world championship title on the basis of total points earned at NHRA national events.

NHRA NATIONAL EVENTS POINTS STRUCTURE (all races except in Indianapolis and Pomona 2)

Winner	100
Runner-up.	80
Third-round loser	60
Second-round loser	40
First-round loser	20

CHEVROLET PERFORMANCE U.S. NATIONALS AND AUTO CLUB NHRA FINALS POINTS STRUCTURE (Indianapolis & Pomona 2)

Winner	150
Runner-up.	120
Third-round loser	90
Second-round loser	60
First-round loser	30

Additional points are awarded at national events as follows:
 10 points to all contestants (15 at Chevrolet Performance U.S. Nationals and Auto Club NHRA Finals) — one qualifying run required.

Performance bonus points are awarded for each qualifying session as follows:

National Events (except Indy and Finals)	U.S. Nationals and Finals
Low e.t. of each session . . . 3	Low e.t. of each session . . . 4
Second-quickest 2	Second-quickest 3
Third-quickest 1	Third-quickest 2
	Fourth-quickest 1

Performance bonus points WILL NOT be awarded for any session unable to be completed.

Qualifying positions earn points as follows:

National events (except Indy and Finals)	U.S. Nationals and Finals
1st 8	1st 10
2nd 7	2nd 9
3rd 6	3rd 8
4th 5	4th 7
5th & 6th 4	5th & 6th 6
7th & 8th 3	7th & 8th 5
9th through 12th 2	9th through 12th 4
13th through 16th 1	13th through 16th 3

For tiebreaker procedures, contact the NHRA Competition Department.

NHRA MELLO YELLO COUNTDOWN TO THE CHAMPIONSHIP

NHRA will continue to use a playoff-style format to determine the NHRA Mello Yello world champion in each of the four Mello Yello categories.

In the regular season, racers in Top Fuel, Funny Car, Pro Stock, and Pro Stock Motorcycle earn points to secure a position in the top 10 in points standings.

To begin the six-race Countdown to the Championship, the playoffs, the top 10 racers in each Mello Yello category will have their NHRA Mello Yello points adjusted as follows:

First place 2,100 points	Sixth place 2,040 points
Second place 2,080 points	Seventh place 2,030 points
Third place 2,070 points	Eighth place 2,020 points
Fourth place 2,060 points	Ninth place 2,010 points
Fifth place 2,050 points	Tenth place 2,000 points

NHRA LUCAS OIL NATIONAL CHAMPIONSHIP

Contestants in the NHRA Lucas Oil Drag Racing Series categories (Super Street is division only) compete for NHRA Sportsman championship titles on the basis of total points earned at NHRA national, regional, and divisional events.

Regional and divisional events: Races feature NHRA Lucas Oil Drag Racing Series points competition within NHRA's seven geographic divisions. Regional and divisional race dates and locations are determined by NHRA in cooperation with host tracks and are announced upon finalization in NHRA *National Dragster*, on NHRARacer.com, and in other publications.

Each Top Alcohol Dragster and Top Alcohol Funny Car driver is eligible to compete for points at five regional and 10 national events. When a driver has competed in those five regional and 10 national events or the season ends at the Auto Club NHRA Finals, his or her best three regional and best seven national finishes will constitute the driver's NHRA Sportsman championship points total.

Each driver in the remaining NHRA Lucas Oil Drag Racing Series categories is eligible to compete for points at eight divisional and six national events. When a driver has competed in those eight divisional and six national events or the season ends at the Auto Club NHRA Finals, his or her best five divisional and best three national finishes will constitute the driver's NHRA Sportsman championship points total.

Once a driver has competed for points at a maximum number of national, regional, and/or divisional events, the driver may compete at additional events but will not receive additional NHRA Lucas Oil Drag Racing Series points.

NHRA LUCAS OIL REGIONAL AND DIVISIONAL CHAMPIONSHIP

To accommodate those NHRA Lucas Oil Drag Racing Series racers who elect to concentrate activity closer to their homes, separate regional and divisional programs are conducted to honor the top points champions in each of NHRA's four regions or seven geographic divisions. Standings for this series are based totally upon NHRA Lucas Oil Drag Racing Series regional and divisional events (national events do not apply).

At the first regional or divisional event a driver enters during the season, said driver must declare which of the four NHRA regions or seven NHRA divisions is to be his or her home division.

That region or division will become his or her home region or division for the season. Contestants are not permitted to be listed in more than one region or division in the same category. Each Top Alcohol Dragster and Top Alcohol Funny Car driver may compete for home-region NHRA Lucas Oil Drag Racing Series points at up to seven regional events and will be credited with points earned for their best five finishes including up to two out-of-region races. Each driver in the remaining NHRA Lucas Oil Drag Racing Series categories may compete for home-division NHRA Lucas Oil series points at up to eight divisional events and will be credited with the points earned for their best five finishes including up to two out-of-division races. A driver may earn points at outside events even after a driver's home-division schedule is completed. To be eligible for official NHRA Lucas Oil Drag Racing Series regional and division points and subsequent postseason awards, a contestant must claim a minimum of three races within his or her home region or division.

TOP DRAGSTER AND TOP SPORTSMAN NATIONAL CHAMPIONSHIP

The two classes will be contested at 14 NHRA Mello Yello Drag Racing Series national events, the JEGS NHRA SPORTSnationals, and all NHRA Lucas Oil Drag Racing Series divisional events. To earn NHRA national championships, drivers in both classes will count their best three of their first five national events and their best five of their first eight divisional events. The JEGS NHRA SPORTSnationals event will be counted as a national events, with competitors earning national event points.

NHRA LUCAS OIL DRAG RACING SERIES POINTS

In all NHRA Lucas Oil Drag Racing Series categories (including Top Alcohol Dragster and Top Alcohol Funny Car), points are awarded at national, regional, and divisional events as follows:

Actual Field Size	1st rd. loser	2nd rd. loser	3rd rd. loser	4th rd. loser	5th rd. loser	6th rd. loser	7th rd. loser	R/U	Win
4 or fewer	33							64	85
5 to 8	32	43						64	85
9 to 16	31	42	53					64	85
17 to 32	30	41	52	63				74	95
33 to 64	30	40	51	62	73			84	105
65 to 128	30	40	50	61	72	83		94	105
129 plus	30	40	50	60	71	82	93	104	115

All remaining event non-qualifiers or no-shows in eliminations will automatically receive 10 points. A minimum of 10 points will be awarded to all contestants upon completion of event tech inspection and registration. Points will not be awarded for qualifying positions in any NHRA Lucas Oil Drag Racing Series categories.

For tiebreaker procedures, contact your NHRA division office.

E3 SPARK PLUGS NHRA PRO MOD DRAG RACING SERIES PRESENTED BY J&A SERVICE

Drivers competing in the E3 Spark Plugs NHRA Pro Mod Drag Racing Series presented by J&A Service will earn championship points at each of the 12 NHRA national events at which they compete. The points will be accumulated throughout the year, and an annual champion will be crowned in the series at the conclusion of the season. Points will be awarded as follows:

Winner	100
Runner-up	80
Third-round	60
Second-round	40
First-round	20

Additional 10 points are awarded to all non-qualifiers - one qualifying run required.

Qualifying positions earn points as follows:

1st	8
2nd	7
3rd	6
4th	5
5th & 6th	4
7th & 8th	3
9th thru 12th	2
13th thru 16th	1

Qualifying points will NOT be awarded at events if the entire 16-car field is determined by points standing.

NHRA MICKEY THOMPSON TOP FUEL HARLEY SERIES

Riders competing in the NHRA Mickey Thompson Top Fuel Harley Series will earn championship points at each of the 10 NHRA National events at which they compete. The points will be accumulated throughout the year, and an annual champion will be crowned in the series at the conclusion of the season. Points will be awarded as follows:

Winner	80
Runner-up	60
Second-round	40
First-round	20

Additional 10 points are awarded to all non-qualifiers - one qualifying run required.

Qualifying positions earn points as follows:

1st	6
2nd	5
3rd	4
4th	3
5th & 6th	2
7th & 8th	1

Qualifying points will NOT be awarded at events if the entire 8-bike field is determined by points standing.

PROFESSIONAL SPECIALTY SERIES

Certain Professional categories are offered sponsored specialty races, to be contested during qualifying portions of established events (i.e., Mickey Thompson Pro Bike Battle in Sonoma).

MICKEY THOMPSON TIRES PRO BIKE BATTLE

The Mickey Thompson Tires Pro Bike Battle program is a special race-within-a-race competition for the Pro Stock Motorcycle category to be held annually during the NHRA Sonoma Nationals. Qualifying for the Mickey Thompson Tires Pro Bike Battle program is based upon points awarded for final qualifying positions at each PSM national event.

Qualifiers:	No. 1	175	No. 9	120
	No. 2	165	No. 10	115
	No. 3	155	No. 11	110
	No. 4	145	No. 12	105
	No. 5	140	No. 13	100
	No. 6	135	No. 14	95
	No. 7	130	No. 15	90
	No. 8	125	No. 16	85

All points are awarded to the rider and cannot be transferred under any circumstances. Points are not transferable from one category to another.

SPECIALTY SERIES — GENERAL

To be eligible to participate in specialty races, qualified drivers must compete in the same class of competition at the host national event. If one of the original qualifiers is unable to race and/or is not competing in the same class at the host national event, the highest-rated alternate will be inserted into the field in the position of the original qualifier. Professional category drivers are limited to a single class of Professional competition at individual national events.

All specialty series participants must display the appropriate decal with unaltered logo, as provided by series sponsor, at all times. If a facsimile is painted on the vehicle (instead of applying the decal), it must be the same size, likeness, and color of the approved series decal and logo authorized by series sponsor. Decal must be displayed prominently.

On Pro Stockers, the decal MUST be placed:

- a) on each side of the front fender in front of the front tire
- b) on each side of the hood scoop

On Pro Stock Motorcycles, the decal MUST be placed:

- a) on each side of the wheelie-bar panel
- b) on each side of the front fairing in front of foot peg

JEGS ALLSTARS

The 2019 JEGS Allstars event will be conducted at the Route 66 NHRA Nationals presented by K&N Filters in Chicago. Points will be awarded up to four to six weeks prior to the 2019 Route 66 NHRA Nationals presented by K&N Filters (check local division office for schedule in your area). JEGS Allstars competition is based on regional and divisional points earned solely within the contestant's home region or division. Contestants declaring a different home region or division at the beginning of the racing season will receive JEGS Allstars points for the most recently declared home region or division.

At that time, the top two points earners in Top Alcohol Dragster and Top Alcohol Funny Car and the top points earners in each of the remaining categories in each of NHRA's four regions and seven divisions will be invited to participate in the JEGS Allstars competition. In addition, the JEGS Allstars champion from the previous year will be invited to participate to establish eight-car fields in each category of competition. The JEGS Allstars champion from Top Alcohol Dragster and Top Alcohol Funny Car will automatically assume one of the two positions of the represented region. If the Top Alcohol Dragster and Top Alcohol Funny Car JEGS Allstars champion does not return, the top two points earners will fill the positions. For all remaining categories, in the event the champion is one of the divisional points leaders, he or she will then become the divisional representative. If the defending JEGS Allstars champion becomes the division representative or cannot compete as the blocker for any reason, the blocker position will remain in the champion's division and will go to the next-highest JEGS Allstars points driver. Example: If the defending JEGS Allstars Competition Eliminator champion is also the division Allstars points leader, he or she will compete as the division representative, and the No. 2 driver in Allstars Competition Eliminator points in that division will go in the blocker position.

The JEGS Allstars team championship will be decided by awarding 100 points for each round won by a regional and divisional representative. The Allstars champion in Comp, SS, STK, SC, SG, SST, TD, and TS from the previous year will be regarded as a "blocker" only and cannot earn points for his or her team. However, he or she will share in any team rewards. Tiebreaker points will be awarded to eliminator winners (9 points), runners-up (7 points), and semifinalists (5 points). Should a tie still exist, qualifying points will be used (8 points for No. 1; 7 points for No. 2; etc.). Pairings will be determined from the regular Route 66 NHRA Nationals qualifying in Chicago or from specific time-trial sessions prior to the JEGS Allstars competition.

Alternates for regional and divisional leaders will be taken from respective regional and divisional points standings. If the points leader in a given division cannot attend, No. 2 is invited, and so on until the position is filled.

Any car used by an Allstars contestant in Allstars competition may be driven only by that contestant during the 2019 Route 66 NHRA Nationals competition.

MANUFACTURERS CUP

The annual NHRA Manufacturers Cup is awarded to the automobile manufacturer whose current-year cars competing in Funny Car, Pro Stock, Super Stock, Factory Stock Showdown and Stock score the most points for qualifying and for winning. Points are earned at NHRA national and divisional events as follows: 60 points for an eliminator win, 40 points for a runner-up, and 20 points for qualifying.

POINTS — GENERAL

All points are awarded to the racer and cannot be transferred under any circumstances. Points are not transferable from one category to another.

If an event is postponed for any reason prior to the start of eliminations for that category, it is necessary that any vehicle and racer still eligible for event competition be in attendance and participate at the rescheduled date to be eligible for all points and cash awards based on eliminator racing. Racers not returning will NOT have the event charged to their quota. If an alternate racer is inserted into a race under these circumstances, he or she will receive full points and awards. Points and awards are based on a round-loss basis, not simply on qualifying.

If an event is disrupted and rescheduled due to weather or other conditions after eliminations of that category are in progress, contestants unable to return will be awarded points up to the round completed before postponement.

If any portion of an event is completely rescheduled for any reason, qualified NHRA Lucas Oil Drag Racing Series contestants unable to return will be granted an automatic withdrawal — earning no points — and the event will not be charged to their event quota. If a contestant does not wish to be withdrawn from the postponed event and desires to receive points earned up until the point of cancellation, contestant must contact the event division director or NHRA Competition Department. If eliminations were in progress at the time of postponement, a winning contestant in a non-Professional category unable to return will receive round money (and points if requested) as if the contestant had lost in the first round contested at the resumed event (regardless of actual round number). A winning contestant in a Professional category unable to return will receive round money (and points) as if the contestant had lost in the prior round.

If an alternate racer is inserted into a race under these circumstances, the alternate will receive full round points and round money.

Non-qualifiers in Top Alcohol Dragster, Top Alcohol Funny Car, Comp, Super Stock, and Stock will receive 10 points regardless of whether an event is postponed and rescheduled. Withdrawal policy does not apply.

Points are awarded in the chronological order a contestant completes each event. For example, if event A is postponed until after event B, those contestants still eligible for competition at the rescheduled event will be awarded points for event B prior to event A. Contestants losing in event A prior to postponement will have event A points awarded prior to event B.

Attempts to set low e.t. will not be permitted after qualifying ends, with the exception of vehicles remaining in category competition. The final run on which a racer is eliminated will be allowed as a low e.t.

LOGO PLACEMENT

All vehicles participating in Mello Yello Drag Racing Series events and other events conducted by NHRA must prominently display an NHRA Championship Drag Racing logo and all other applicable logos as shown in this section to be eligible for competition. Logos must be properly displayed to enter an NHRA event, to pass technical inspection, and to make any runs. Logos must continue to be properly displayed at all times during the conduct of any event. If a run is inadvertently allowed without proper logo usage, points shall be withheld from any contestant who fails to display the logos as required and all other penalties for rule violations shall also apply, including disqualification of any run, during qualifying or eliminations, made without displaying the logos as required.

In addition, no participant in an NHRA Mello Yello Drag Racing Series event may display on his or her driver uniform, team uniform, vehicle, transporter, trailer, or in any other way at the NHRA Mello Yello Drag Racing Series event site, any non-Mello Yello "Carbonated Soft Drink" beverage name, mark, logo, or other indicia, unless such Carbonated Soft Drink sponsorship is evidenced by a signed contract for FULL SEASON PRIMARY SPONSORSHIP existing as of Aug. 29, 2012. "Carbonated Soft Drink" shall mean carbonated soft drinks and carbonated soft-drink branded products (whether or not the product is a carbonated soft drink or other beverage product), but NO PEPSICO PRODUCTS ARE ELIGIBLE FOR TREATMENT UNDER THE GRANDFATHER CLAUSE. Full details of requirements to qualify under the Grandfather Clause are available from the NHRA Marketing Department. Any participant who violates the foregoing rule shall be banned from competition at the NHRA Mello Yello Drag Racing Series event.

Required logo placement is as follows:

Mello Yello Categories – Vehicle. Must display the NHRA Mello Yello Drag Racing Series logo on both sides of the race vehicle at all times during any national event, using the official decal supplied by NHRA. Any required specialty race logos must also be displayed as designated and supplied by NHRA to be eligible for specialty race points.

Mello Yello Categories – Driver/Rider Uniform. NHRA Mello Yello Drag Racing Series patch must be worn on each Mello Yello category driver/rider uniform. Patch must be 3.25 inches wide by 3.75 inches tall. NHRA also authorizes and encourages the Series patch to be featured on crewmember uniforms. Required location for the NHRA Mello Yello Drag Racing Series patches as shown in diagram.

Sportsman Categories – Vehicle. In all NHRA Lucas Oil Drag Racing Series categories, the NHRA Lucas Oil Drag Racing Series logo must be displayed on both sides of the race vehicle at all times during any NHRA Lucas Oil Drag Racing Series event, including those that occur within the NHRA Mello Yello Drag Racing Series events. Must use the official decal supplied by NHRA. On other vehicles, required logo must be in a prominent location somewhere between the front

Top Fuel: NHRA Mello Yello Drag Racing Series decal placement outside bottom rear corner of spill plate

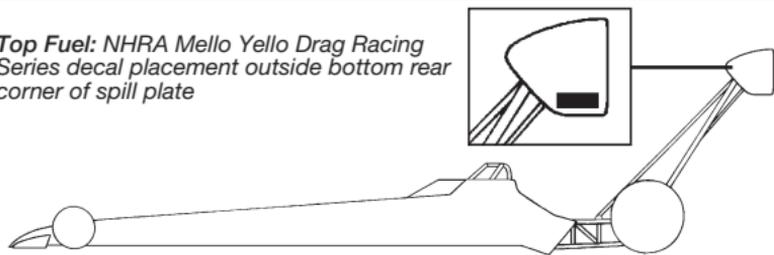

Funny Car: NHRA Mello Yello Drag Racing Series decal placement outside upper rear corner of spill plate

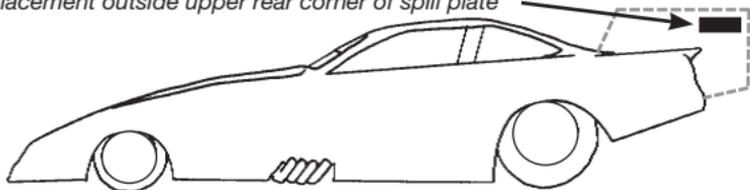

Pro Stock: NHRA Mello Yello Drag Racing Series decal placement outside rear edge of spill plate

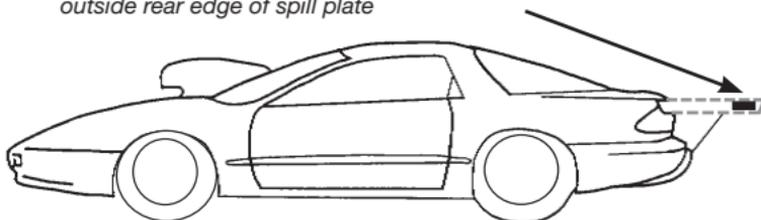

Pro Stock Motorcycle: upper forward part of fairing, directly under handlebar cutout

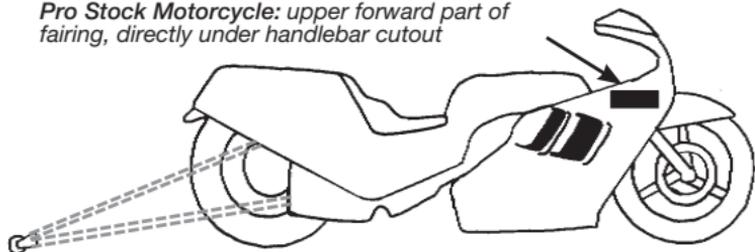

spindle and rear axle, and above the axle centerline, or on outside of spill plates if spill plate is of a sufficient size. Must use the official decal supplied by NHRA. Any required specialty race logos must also be displayed as designated by NHRA to be eligible for specialty race points (e.g., JEGS Allstars).

Required patch placement for Professional category driver/rider uniforms

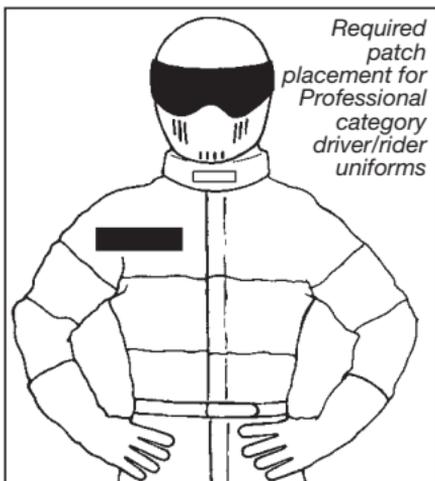

Pro Mod – Vehicle. Must display the E3 Spark Plugs NHRA Pro Mod Drag Racing Series presented by J&A Service logo on both sides of the race vehicle at all times during a national event, using the official decal supplied by NHRA. Any required specialty race logos must also be displayed as designated and supplied by NHRA to be eligible for specialty race points.

Pro Mod – Driver Uniform. E3 Spark Plugs NHRA Pro Mod Drag Racing Series presented by J&A Service patch must

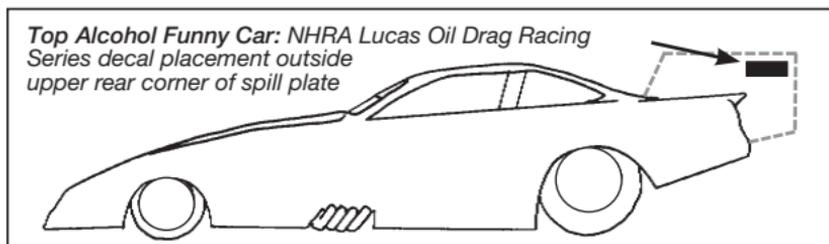
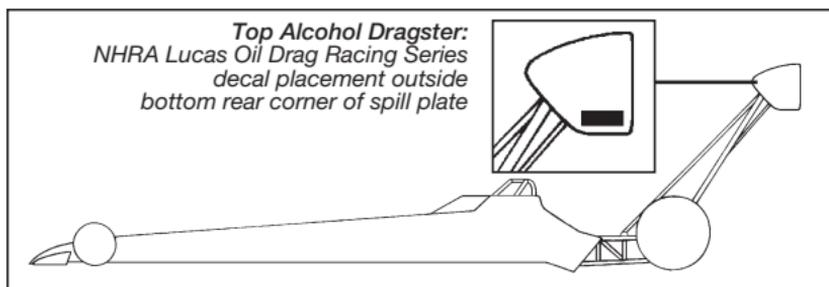

be worn on the driver's uniform. Patch must be easily visible and recognizable. NHRA also authorizes and encourages the series patch to be featured on crewmember uniforms. Required location for the E3 Spark Plugs NHRA Pro Mod Drag Racing Series presented by J&A Service patches as shown in diagram.

Any contestant disqualified for mechanical noncompliance loses all points for that particular event. The race will be charged to the contestant's overall quota of races attended, and depending on the nature and circumstances of the infraction, the contestant may be charged with a non-replaceable "zero grade" event that will be used as one of the scored events in calculating national and/or divisional standings. Contestants will be notified in writing when a non-replaceable zero grade action has been determined to be part of the penalties assessed for disqualification.



E.T. HANDICAP RACING

**Stock-Body Vehicles, Altered-Body Vehicles,
Dragsters, Motorcycles, Snowmobiles,
All-Terrain Vehicles, and Electric Vehicles**

Each racetrack has the option of substituting its own selection of class titles and e.t. breaks.

Since quarter-mile elapsed times would not apply for eighth-mile racing, a style of competition common to E.T. handicap racing, some pertinent quarter-mile elapsed times are converted to eighth-mile figures: 9.90 = 6.30, 10.00 = 6.40, 11.00 = 7.00, 12.00 = 7.50, and 14.00 = 8.60.

The legality of certain devices (i.e., throttle stops, delay devices, etc.) may vary between divisions. Racers are advised to contact the respective division office for regulations within that geographic area.

Timed vehicle-control devices (counters, time displays, etc.), except as outlined under Class Requirements, are prohibited. Display or transmission of track location, time/distance data, etc. prohibited.

Data recorders are permitted in Advanced E.T. and Super Pro only. Data recorders (except for "playback"-type tachometers) are prohibited in all other E.T. classes.

Computers (except for OEM) are prohibited in all E.T. classes.

SECTION 4A

SUPER PRO, PRO, SPORTSMAN

7.50 (*4.50) seconds & slower

DESIGNATIONS

NHRA SUMMIT RACING SERIES NATIONAL CHAMPIONSHIP

SUPER PRO: 7.00 to 11.99

PRO: 9.00 to 13.99

SPORTSMAN: 12.00 to 19.99

References in this section identify performance limits for various equipment and safety applications.

Any vehicle except E.T. Motorcycle running faster than 135 mph must meet minimum requirements for 9.99-second vehicles including driver credentials and protective clothing. The 135-mph rule does not apply to E.T. Motorcycle. E.T. Motorcycle must comply with 9.99-second e.t. restrictions.

REQUIREMENTS & SPECIFICATIONS

ENGINE: 1

ENGINE

One internal-combustion automotive-type, motorcycle, or snowmobile engine permitted. Motorcycle or snowmobile-powered vehicles without reverse may not burn out across starting line. Harmonic balancer meeting SFI Spec 18.1 mandatory in any car running 10.99 (*6.99) or quicker. Maximum height of crankshaft centerline 36 inches for trucks running 12.00 and slower; 31 inches for trucks running 11.99 to 10.00; and 24 inches for trucks running 9.99 seconds and quicker. See General Regulations 1:1.

EXHAUST SYSTEM

Competition exhaust permitted. Exhaust must be directed out of car to rear, away from driver and fuel tank. For cars running quicker than 7.50 (*4.50), see Advanced E.T. Requirements. See General Regulations 1:3.

FUEL

Racing gasoline, gasoline, alcohol, gasohol, diesel, ethanol, natural gas, and propane permitted. Nitromethane prohibited.

FUEL SYSTEM

All fuel-tank filler necks located inside trunk must have filler neck vented to outside of body. Vented caps prohibited. All batteries, fuel lines, fuel pumps, or filler necks located inside trunk require complete bulkhead of at least .024-inch steel or .032-inch aluminum to isolate driver compartment from trunk. Fuel lines must be located outside driver compartment. Fuel tanks must be within confines of the body. See General Regulations 1:5.

INDUCTION

Electronic fuel injection permitted. Any induction permitted. Open-loop systems permitted on production vehicles as equipped with OEM electronic fuel injection. See General Regulations 9:1, 9.11.

Aftermarket water-methanol injection systems permitted. Must be installed and used per manufacturer's instructions. Tank, pump, lines, etc. may not be mounted inside the driver compartment. When located inside trunk, a complete bulkhead of at least .024-inch steel or .032-inch aluminum is required to isolate driver compartment from trunk.

LIQUID OVERFLOW

Catch-can mandatory for coolant overflow; one-pint (16-ounce) minimum capacity. See General Regulations 1:7.

NITROUS OXIDE

Commercially available nitrous oxide permitted, including supercharged and turbocharged engines. Nitrous bottle(s) in driver compartment must be equipped with a relief valve and vented outside of driver's compartment. Bottle(s) must be stamped with a DOT-1800 pound rating and permanently mounted (no hose clamps or tie wraps). Hoses from bottle(s) to solenoid must be high-pressure steel-braided or NHRA-accepted hoses. Commercially available, thermostatically controlled, blanket-type warmer accepted. The use of a torch or any other external heating of bottle prohibited.

OIL-RETENTION DEVICE

All vehicles permitted to utilize an NHRA-accepted lower engine oil- retention device. See General Regulations 1:8.

SUPERCHARGER, TURBOCHARGER

Permitted on gasoline, racing-gasoline, and alcohol-burning cars. Supercharger restraint system meeting SFI Spec 14.1 mandatory on Roots-type supercharger when alcohol is used as fuel. High-helix, centrifugal and screw-type supercharger permitted. Screw-type supercharger, manifold burst panel meeting SFI Spec 23.1 (in addition to panel in supercharger) plus restraint system meeting SFI Spec 14.21 mandatory. OEM-type screw superchargers do not require a supercharger burst panel or restraint. "OEM-type" in this case means that it must have originally come with the production engine being used. Supercharger drive must be belt, NHRA-accepted chain driver or NHRA-accepted gear drive. Supercharger restraint straps must be covered with a fire-resistant material. The blower restraint straps and fuel lines must be installed such that when the restraint straps are fully extended, no load is placed on any of the fuel lines. Air-to-air or water-to-air intercoolers permitted on turbocharged and centrifugal supercharged vehicles. See General Regulations 1:10.

VALVE COVERS

Cast or fabricated metal valve covers, using all attachment bolt holes, mandatory on supercharged, methanol-burning cars.

DRIVETRAIN: 2**CLUTCH, FLYWHEEL, FLYWHEEL SHIELD**

Flywheel and clutch meeting SFI Spec 1.1 or 1.2 (two-disc maximum) mandatory on any car running 11.49 (*7.35) or quicker or cars powered by rotary engines running 13.49 (*8.25) or quicker. Flywheel shield meeting SFI Spec 6.1, 6.2, or 6.3 mandatory on all cars running 11.49 (*7.35) or quicker. Cars with rotary engines running 11.49 (*7.35) or quicker must be equipped with a flywheel shield made of 1/4-inch-minimum-thickness steel plate completely surrounding the bellhousing 360 degrees, extending 1 inch forward and 1 inch rearward of the rotating clutch assembly; shield may not be notched or cut in any way. Shield must be securely attached to frame or frame structure, may be multi-piece. All rotary engine vehicles equipped with nitrous-oxide injection and/or turbo/supercharger running 9.99 or quicker or 135 mph must use a flywheel shield labeled as meeting SFI Spec 6.1 minimum. Cars for which an SFI Spec 6.1, 6.2, or 6.3 flywheel shield is not available may use an SFI flywheel shield from another application bolted to a motor plate that is bolted to the engine at all available bolt holes. See General Regulations 2:3, 2:5, 2:6, 2:10.

DRIVELINE

OEM production line all-wheel-drive vehicles permitted. Driveshaft loop required on all cars running 13.99 (*8.59) or quicker and utilizing slicks, except vehicles running 11.49 (*7.35) seconds or slower equipped with street tires. See General Regulations 2:4.

REAR END

Aftermarket axles and axle-retention device mandatory on any car running 10.99 (*6.99) or quicker or any car with locked differential. Cars running 10.99 (*6.99) or quicker that weigh more than 2,000 pounds with independent rear suspension without upper and lower (both) control arms must replace swing axle differential with conventional differential housing assembly. (Example: 1963-1982 Corvette). Cars with independent rear suspension using upper and lower (both) control arms may retain swing axle assembly regardless of weight or e.t. Must have 360-degree, minimum 1-inch-wide by 1/4-inch-thick axle retention loop on each axle. See General Regulations 2:11.

TRANSMISSION, AFTERMARKET PLANETARY

Transmission shield meeting SFI Spec 4.1 mandatory on any supercharged or turbocharged vehicle, or any vehicle burning methanol or nitrous oxide, running 9.99 seconds or quicker and equipped with aftermarket planetary transmission. See General Regulations 2:12, 2:13.

TRANSMISSION, AUTOMATIC

Spring-loaded, positive reverse lockout device and functional neutral safety switch mandatory. Transmission shield meeting SFI Spec 4.1 mandatory on any car running 10.99 (*6.99) or quicker or any car exceeding 135 mph. Automatic transmission flexplate meeting SFI Spec 29.1 and flexplate shield meeting SFI Spec 30.1 mandatory on cars running 9.99 (*6.39) or quicker or any car exceeding 135 mph. See General Regulations 2:12, 2:14.

BRAKES & SUSPENSION: 3**BRAKES**

Four-wheel hydraulic brakes mandatory on any bodied car running 7.99 (*4.99) or quicker. Minimum two rear-wheel (one caliper per wheel) hydraulic brakes mandatory on dragsters, Funny Cars, and any car running slower than 8.00 (*5.00) seconds. Dragsters running slower than 10.99 (*6.99) with a total car weight of 1,000 pounds or less and a one-piece rear axle may use a single brake rotor with dual calipers. See General Regulations 3:1.

STEERING

See General Regulations 3:3, 4:1.

SUSPENSION, ALTEREDS, DRAGSTERS

Full automotive-type front suspension mandatory. Rigid mounted rear axles permitted. Minimum one hydraulic shock absorber per sprung wheel. Suspension optional on cars weighing 2,350 pounds or less with 100-inch or longer wheelbase. See General Regulations 3:2, 3:4, 3:5.

SUSPENSION, STOCK-BODIED CARS

Full automotive-type suspension mandatory. Minimum one operating hydraulic shock absorber per wheel. Lightening of stock components prohibited. Rigid mounted suspensions prohibited. See General Regulations 3:2, 3:4, 3:5.

WHEELIE BARS

Permitted. Wheels must be nonmetallic. See General Regulations 3:6.

FRAME: 4**BALLAST**

Permitted. See General Regulations 4:2.

DEFLECTOR PLATE

Mandatory on rear-engine dragsters. See General Regulations 4:3.

GROUND CLEARANCE

Minimum 3 inches from front of car to 12 inches behind centerline of front axle, 2 inches for remainder of car, except oil pan and headers. See General Regulations 4:5.

PARACHUTE

Mandatory on any car that runs 150 mph or faster. See General Regulations 4:8.

ROLL BAR

Roll bar mandatory in all cars (including T-tops) running 11.00 (*7.00) to 11.49 (*7.35), in convertibles running 11.00 (*7.00) to 13.49 (*8.25), and in all dune-buggy-type vehicles running 12.00 (*7.50) seconds and slower. Permitted in all cars. See General Regulations 4:10, 10:6.

ROLL CAGE

A roll cage is mandatory in cars running 10.99 (*6.99) or quicker or any car exceeding 135 mph. In full-bodied cars, with unaltered firewall, floor, and body (from firewall rearward, wheel tubs permitted), running between 10.00 (*6.40) and 10.99 (*6.99), roll bar permitted in place of roll cage. In convertibles running 10.99 or quicker or exceeding 135 mph, roll cage mandatory. See General Regulations 4:4, 4:11, 10:6.

ROLL-CAGE PADDING

Roll-cage padding meeting SFI Spec 45.1 mandatory on any vehicle running 9.99 (*6.39) and quicker. Padding must be used anywhere driver's helmet may come in contact with roll-cage components. See General Regulations 4:11, 10:6.

WHEELBASE

Minimum 85 inches, unless OEM was less and vehicle is equipped with OEM engine and drivetrain. Maximum wheelbase variation from left to right: 1 inch. Dragsters: 2 inches. Minimum front tread width: 26 inches on any dragster.

TIRES & WHEELS: 5**TIRES**

Racing slicks permitted. Minimum diameter of 13 inches on front tires of any dragster. See General Regulations 5:1.

WHEELS

Must be automotive-type wheels suitable for street use. Minimum wheel size: 13 inches (unless originally equipped with smaller wheels and vehicle is equipped with original engine). The thread engagement on all wheel studs to the lug nut, or lug bolt to wheel hubs, must be equivalent to or greater than the diameter of the stud. Length of the stud/bolt does not determine permissibility; length of the engagement between the stud and lug determines permissibility. Automotive-type wire wheels or motorcycle wheels permitted on front axle only of dragsters weighing 1,800 pounds or less. See General Regulations 5:2.

INTERIOR: 6**SEATS**

Properly braced, framed, and supported seats constructed of aluminum, fiberglass, carbon fiber, or double-layer poly (automotive accessory seats) permitted. See General Regulations 6:2.

SHEET METAL

Driver-compartment interior must be aluminum, steel, NHRA-accepted carbon fiber, or fiberglass. Magnesium prohibited.

UPHOLSTERY

Optional. See General Regulations 6:2.

WINDOW NET

A ribbon-type or SFI 27.1 mesh-type window net is mandatory for any full-bodied car running 7.50 (*4.50) to 9.99 (*6.39) or if vehicle runs 135 mph or faster. See General Regulations 6:3.

BODY: 7**AIRFOIL**

Altered, dragsters: A positive-locking device mandatory on all airfoils. Side-mount canard-type wings permitted. No part of wing may be within 6 inches of a tire. Front overhang may not project more than 30 inches forward of front spindle.

Bodied vehicles: Non-OEM airfoils permitted, must be permanently attached to frame or roll cage, non-adjustable during run.

BODY

Altered-body vehicles: May be chopped, channeled, sectioned, streamlined, etc. Sedan delivery, pickup trucks (maximum, one ton), or sedan pickups (Ranchero, El Camino) permitted. Fiberglass bodies permitted. Door hinges on any lift-off door must have safety pins or locks.

Dragsters: Body and cowl must be constructed of metal, fiberglass, or carbon fiber and extend forward to firewall. Driver compartment must be designed to prevent driver's body or limbs from making contact with wheels, tires, exhaust system, or track surface should an incident occur. Subflooring independent of car body is mandatory in dragster that allows driver's legs to rest on belly pan or chassis. On front-engine cars, intake scoop may not extend more than 11 inches above height of carburetor top. Front wheel fairings prohibited.

Full-bodied vehicles: Must have full top and windshield. All full-bodied cars must have two driver exits. Four stock production fenders mandatory, fiberglass duplicates permitted. Fenders may be trimmed for tire clearance; altered fenders must have edges re-rolled or beaded.

FIREWALL

Mandatory. See General Regulations 6:1, 7:4.

FLOOR

Mandatory. See General Regulations 6:1, 7:5.

HOOD

Optional. Carburetors must be covered by flash shield or scoop. Hood scoop permitted. See General Regulations 1:4, 7:6.

WINDSHIELD, WINDOWS

Altered, dragsters: Optional. Windscreen mandatory. See General Regulations 7:7, 7:8.

Stock-bodied vehicles: Mandatory, must be in good condition and free from cracks. May be replaced with shatterproof material, 1/8-inch-minimum thickness. OEM windshield may not be cut for scoops, carb, etc. Windshield/window tint must meet the applicable state requirements. Windows must be closed during races, need not be operable. Decals permitted on rear quarter and rear window only. See General Regulations 7:8.

ELECTRICAL: 8**BATTERIES**

Batteries must be securely mounted, may not be located in driver compartment. See General Regulations 8:1.

DELAY BOX/DEVICE

Permitted in Advanced E.T. and Super Pro only. See General Regulations 8:2.

IGNITION

Timed ignition-interruption devices (stutter boxes) prohibited. Starting-line and/or "high-side" rev limiters permitted. Two-steps, rev limiters, or any other rpm-limiting devices, legal unto themselves but altered or installed so as to function as a down-track rpm controller, prohibited.

All wiring associated with the ignition system must be fully visible, labeled, and traceable. See General Regulations 8:3.

INSTRUMENTS

One tachometer allowed. Driveshaft sensor may be connected to either the tachometer OR the data recorder, but not both. Must be one single wire, with no splices, and easily traceable.

MASTER CUTOFF

Mandatory on any car with a battery running 9.99 (*6.39) or quicker, any car exceeding 135 mph, or on any car where the battery is relocated into the trunk area. See General Regulations 8:4.

STARTING LINE CONTROLLERS

Only pneumatic starting line controllers permitted in Advance E.T. and Super Pro only. Only mechanical starting line controllers permitted in Pro and Sportsman only. Use of mechanical device must be completely in driver's control. Release of mechanical device must be spring activated only (released on full throttle activation). All other forms of starting line controllers prohibited in all E.T. classes.

TAILLIGHTS

One functional taillight mandatory. Flashing, blinking, or strobe lights prohibited. See General Regulations 8:6.

SUPPORT GROUP: 9**COMPUTER**

Prohibited. See General Regulations 9:1.

DATA RECORDER

Data recorders are permitted in Advanced E.T., Super Pro, and Pro only. Data recorders (except for "playback"-type tachometers) are prohibited in all other E.T. classes. See General Regulations 9:2.

FIRE-EXTINGUISHER SYSTEM

Permitted; must be securely mounted. See General Regulations 9:3.

PUSH BAR

Push bar must be designed to prevent push car from riding up on rear wheel of open-wheeled race cars. See General Regulations 9:9.

TOW VEHICLES

Permitted in Super Pro only. See General Regulations 9:12.

WARM-UPS

See General Regulations 9:5, 9:14.

DRIVER: 10**ARM RESTRAINTS**

Mandatory in open-bodied cars running 11.99 (*7.49) or quicker. See General Regulations 6:3, 10:3.

CREDENTIALS

Valid NHRA competition license mandatory for cars running 9.99 (*6.39) or quicker. Valid state- or government-issued driver's license beyond a learner's-permit level mandatory for cars running 10.00 (*6.40) or slower. See General Regulations 10:4.

DRIVER RESTRAINT SYSTEM

Seat belt mandatory in all cars. Driver restraint system meeting SFI Spec 16.1 mandatory in any car running 11.49 (*7.35) or quicker, in convertibles running 13.49 (*8.25) or quicker, and all dune-buggy-type vehicles running 12.00 (*7.50) or slower. SFI 16.1 restraint system, when required, includes crotch strap and must be updated at two-year intervals from date of manufacture. See General Regulations 10:5, 10:11.

HEAD PROTECTOR

Mandatory on any car with a roll bar or roll cage. See General Regulations 10:6.

HELMET

For all 10.00 to 13.99 closed-bodied cars, either an open-face or a full-face Snell M2010, M2015, SA2010, SA2015, SFI 31.1/2010 or 31.1/2015 helmet with or without a shield is mandatory.

For all 10.00 and slower dune-buggy-type vehicles and all 10.00 to 13.99 open-bodied front-engine or rear-engine supercharged, turbocharged, nitrous, or naturally aspirated cars, a full-face Snell M2010, M2015, SA2010, or SA2015 helmet and shield mandatory (goggles prohibited).

For all 9.99 and quicker closed-bodied cars, a full-face Snell M2010, M2015, SA2010 or SA2015 helmet mandatory; shield permitted (goggles prohibited).

For all 9.99 and quicker open-bodied front-engine or rear-engine supercharged, turbocharged, or nitrous cars, a full-face Snell SA2010, or SA2015 helmet and shield mandatory (goggles prohibited).

For all 9.99 or quicker open-bodied front-engine or rear-engine naturally aspirated cars, a full-face Snell M2010, M2015, SA2010, or SA2015 helmet and shield mandatory (goggles prohibited). See General Regulations 10:7.

NECK COLLAR

Neck collar meeting SFI Spec 3.3 mandatory in all cars running 9.99 (*6.39) or quicker or cars exceeding 135 mph. A head and neck restraint device/system may be used in lieu of a neck collar. See General Regulations 10:8.

If SFI Spec 3.3 neck collar is required and driver opts to use head and neck restraint system instead, then SFI Spec 3.3 head sock or SFI Spec 3.3 skirted helmet mandatory.

PROTECTIVE CLOTHING

Full-length pants; short- or long-sleeved shirt; closed shoes; and socks. No shorts. No tank tops. No open-toe or open-heel shoes or sandals. Synthetic clothing not recommended.

10.00 (*6.40) to 13.99 (*8.59); all E.T. non-OEM supercharged, non-OEM turbocharged, or nitrous-equipped cars with an OEM or .024-inch steel firewall: Jacket meeting SFI Spec 3.2A/1 mandatory.

10.00 (*6.40) to 13.99 (*8.59); all E.T. supercharged, turbocharged, or nitrous-equipped cars without a full OEM or .024-inch steel firewall: Jacket meeting SFI Spec 3.2A/5 and gloves meeting SFI Spec 3.3/1 mandatory.

9.99 (*6.39) to 7.50 (*4.50) front-engine open-bodied vehicles with nitrous oxide, supercharger, or turbocharger(s): Jacket and pants meeting SFI Spec 3.2A/15, gloves, and shoes or boots meeting SFI Spec 3.3/5 mandatory.

9.99 (*6.39) to 7.50 (*4.50) closed-bodied vehicles without an OEM or full .024-inch steel firewall with nitrous oxide, supercharger, or turbocharger(s): Jacket and pants meeting SFI Spec 3.2A/15, gloves meeting SFI Spec 3.3/5, and shoes or boots meeting SFI Spec 3.3/5 mandatory.

10.00 (*6.40) to 11.49 (*7.35); all E.T. naturally aspirated, OEM supercharged, or OEM turbocharged with a full OEM or .024-inch steel firewall: Jacket meeting SFI Spec 3.2A/1 mandatory.

9.99 (*6.39) to 7.50 (*4.50) or any vehicle exceeding 135 mph: Jacket and pants meeting SFI Spec 3.2A/5 and gloves meeting SFI Spec 3.3/1 mandatory, except as noted above.

All open-body vehicles running 11.99 or quicker: Gloves meeting SFI Spec 3.3/1 and arm restraints mandatory.

Dune-buggy or dune-buggy-type vehicles, 12.00 (*7.50) or slower: Jacket meeting SFI Spec 3.2A/1, gloves meeting SFI Spec 3.3/1, and arm restraints mandatory.

Any vehicle with an automatic transmission in driver compartment (no floor covering transmission): Jacket and pants or suit meeting SFI Spec 3.2A/15, gloves meeting SFI Spec 3.3/5, and boots or shoes meeting SFI Spec 3.3/5 mandatory.

9.99 and faster, any vehicle, supercharged or turbocharged with alcohol: Suit meeting SFI Spec 3.2A/15, gloves and boots meeting SFI Spec 3.3/5 mandatory, except as noted above.

SECTION 4B ADVANCED E.T.

6.00 (*3.66) to 7.49 (*4.49) seconds

Requirements and specifications for Advanced E.T. are the same as those for E.T. handicap racing - Section 4A - with the following exceptions:

For cars running between 7.49 (*4.49) and 6.00 (*3.66) seconds.

Computers (except OEM) are prohibited in all E.T. brackets.

REQUIREMENTS & SPECIFICATIONS

ENGINE: 1

ENGINE

Harmonic balancer meeting SFI Spec 18.1 mandatory.

EXHAUST

Double-pipe or thermal-wrapped insulated headers mandatory on supercharged, methanol-burning bodied cars. Insulation must extend to start of bend in headers at bottom of body.

NITROUS OXIDE

Nitrous oxide prohibited on supercharged or turbocharged engines, except when diesel fuel used.

OIL-RETENTION DEVICE

All vehicles running 7.49 or quicker must utilize an NHRA-accepted lower engine oil-retention device; may use a belly pan in lieu of a device attached to the engine. The belly pan must extend from framerail to framerail and extend forward of the harmonic balancer and rearward to rear engine plate and must incorporate a minimum 2-inch-high lip on all sides. A nonflammable, oil-absorbent liner mandatory inside of retention device. See General Regulations 1:8.

SUPERCHARGER

Use of high-helix supercharger permitted. Screw-type superchargers permitted. Screw-type supercharger must meet SFI Spec 34.1 and be reinspected by the manufacturer every three years. Manifold burst panel meeting SFI Spec 23.1 (in addition to panel in supercharger) plus restraint system meeting SFI Spec 14.21 mandatory on all screw-type superchargers. All other superchargers, restraint system meeting SFI Spec 14.1 mandatory. Supercharger restraint straps must be covered with a fire-resistant material. The blower restraint straps and fuel lines must be installed such that when the restraint straps are fully extended no load is placed on any of the fuel lines. See General Regulations 1:10.

DRIVETRAIN: 2**CLUTCH, FLYWHEEL, FLYWHEEL SHIELD**

Flywheel and clutch meeting SFI Spec 1.1, 1.2, 1.3, or 1.4 mandatory. Flywheel shield meeting SFI Spec 6.2 or 6.3 mandatory on all supercharged or turbocharged cars and all cars using nitrous oxide. Flywheel shield meeting SFI Spec 6.2 or 6.3 mandatory on all cars using SFI Spec 1.2 clutch with more than two discs or SFI Spec 1.3 or 1.4 clutches with two discs maximum. Flywheel shield meeting SFI Spec 6.2 mandatory on all cars using SFI 1.3 or 1.4 clutches with more than two discs. Cars for which an SFI Spec 6.2 or 6.3 flywheel shield is not available may use an SFI flywheel shield from another application bolted to a motor plate that is bolted to the engine at all available bolt holes, or use a fabricated shield made of 1/4-inch-thick steel, surrounding the bellhousing 360 degrees, extending 1 inch forward and 1 inch rearward of the rotating clutch assembly. Shield must be securely attached to frame or frame structure; may be multi-piece. All rotary engine vehicles must be equipped with a flywheel shield meeting SFI Spec 6.2 or 6.3 minimum. Multi-disc clutch assembly for supercharged, nitrous-oxide injected, and turbocharged vehicles must meet SFI Spec 1.5. See General Regulations 2:3, 2:5, 2:6, 2:10.

DRIVELINE

All full-bodied vehicles, where the OEM floor has been removed, each end of driveshaft must have round 360-degree driveshaft loops within 6 inches of U-joints. Additionally, driveshaft must be covered by 360-degree tube, covering the front U-joint and extending rearward a minimum 12 inches. Minimum thickness of tube is .050-inch chromoly or titanium. Driveshaft tube must utilize a minimum of four attachment points to the chassis, either bolted with minimum 5/16 SAE bolts or welded or 1/4-inch push/pull pins. See General Regulations 2:4.

REAR END

Aftermarket axles and axle-retention devices mandatory. Welded spider gears prohibited. Wheel studs must be 5/8-inch minimum. Aftermarket full-floating or live axle assembly permitted. Independent rear suspension prohibited.

TRANSMISSION, AFTERMARKET PLANETARY

Transmission shield meeting SFI Spec 4.1 mandatory. See General Regulations 2:12, 2:13.

TRANSMISSION, AUTOMATIC

Transmission shield meeting SFI Spec 4.1 mandatory. Automatic transmission flexplate meeting SFI Spec 29.1 and flexplate shield meeting SFI Spec 30.1 mandatory. See General Regulations 2:12, 2:14.

BRAKES & SUSPENSION: 3**BRAKES**

Four-wheel hydraulic brakes mandatory on any bodied car. Minimum two rear-wheel (one caliper per wheel) hydraulic brakes mandatory on dragsters and Funny Cars. See General Regulations 3:1.

STEERING

If removable steering wheel is used, commercially available quick-disconnect steering-wheel adapter meeting SFI Spec 42.1 mandatory. See General Regulations 3:3.

FRAME: 4**PARACHUTE**

Mandatory. See General Regulations 4:8.

ROLL CAGE

Full-bodied cars must meet SFI Spec 25.1, 25.2, or 25.3; Funny Cars and open-bodied altered cars must meet SFI Spec 10.1 or 10.2. All front-engine dragsters must meet SFI Spec 2.2 or 2.4. All rear-engine dragsters must meet SFI Spec 2.1 or 2.5. See General Regulations 4:4, 4:11, 10:6.

ROLL-CAGE PADDING

Roll-cage padding meeting SFI Spec 45.1 mandatory anywhere driver's helmet may come in contact with roll-cage components. See General Regulations 4:11.

INTERIOR: 6**UPHOLSTERY**

For all front-engine open-bodied vehicles supercharged or turbocharged (gasoline- or methanol-burning), a flame-retardant-material-covered seat is mandatory.

WINDOW NET

An SFI 27.1 ribbon-type or mesh-type window net is mandatory on any full-bodied car running 6.00 (*3.66) to 7.49 (*4.49). SFI 27.1 window net, when required, must be updated at two-year intervals from the date of manufacture. See General Regulations 6:3.

BODY: 7**AIRFOILS**

Non-OEM airfoils or wings permitted on stock bodied vehicles; must be permanently attached to frame or roll cage, non-adjustable during run.

SUPPORT GROUP: 9**DATA RECORDERS**

Data recorders are permitted in Advanced E.T. and Super Pro only. Data recorders (except for "playback"-type tachometers) are prohibited in all other E.T. classes.

FIRE EXTINGUISHER SYSTEM

Minimum 5-pound NHRA-accepted system mandatory on all cars, except rear-engine cars WITHOUT an enclosed cockpit. Minimum 20-pound NHRA-accepted system mandatory on all front-engine open-bodied vehicles with supercharger or turbocharger(s) and all supercharged methanol-burning cars (full-bodied or Funny Car). System must be divided with a minimum one nozzle directed into the driver compartment and minimum one nozzle directed into the engine compartment. See General Regulations 9:3 for NHRA-accepted fire extinguishing agents.

TOW VEHICLES

Permitted. See General Regulations 9:12.

DRIVER: 10**ARM RESTRAINTS**

Mandatory in open-bodied cars and Funny Cars. See General Regulations 6:3, 10:3.

CREDENTIALS

Valid NHRA competition license mandatory. See General Regulations 10:4.

DRIVER RESTRAINT SYSTEM

Driver restraint system meeting SFI Spec 16.1 mandatory. All belts used in open-bodied front-engine supercharged methanol-burning vehicles must be covered with a fire-resistant covering. Restraint system must be updated at two-year intervals from date of manufacture. See General Regulations 10:5.

HELMET

For all closed-bodied cars, a full-face Snell M2010, M2015, SA2010, or SA2015 helmet mandatory; shield mandatory (goggles prohibited).

For all open-bodied front-engine or rear-engine supercharged, turbocharged, or nitrous cars, a full-face Snell SA2010, or SA2015 helmet and shield mandatory (goggles prohibited).

For all open-bodied naturally aspirated gasoline- or methanol-burning cars, a full-face Snell M2010, M2015, SA2010, or SA2015 helmet and shield mandatory (goggles prohibited). See General Regulations 10:7.

NECK COLLAR/HEAD AND NECK RESTRAINT DEVICE/SYSTEM

A head and neck restraint device/system meeting SFI 38.1 is mandatory and must display a valid SFI label. At all times that the driver is in the race vehicle, from the ready line until the vehicle is on the return road, driver must properly utilize an SFI 38.1 head and neck restraint device/system, including connecting the helmet as required for full functionality of the device. The SFI 38.1 head and neck restraint device/system, when connected, must conform to the manufacturer's mounting instructions, and it must be configured, maintained, and used in accordance with the manufacturer's instructions. See General Regulations 10:8.

PROTECTIVE CLOTHING

Jacket and pants or suit meeting SFI Spec 3.2A/15, gloves meeting SFI Spec 3.3/5, and boots or shoes meeting SFI Spec 3.3/5 mandatory, except front-engine open-bodied vehicles with supercharger or turbocharger(s): Jacket and pants or suit meeting SFI Spec 3.2A/20, gloves meeting SFI Spec 3.3/15, and boots or shoes meeting SFI Spec 3.3/15 mandatory. An SFI 3.3 head sock or SFI 3.3 skirted helmet is required on all open-bodied cars or all cars 7.49 and quicker, where a neck collar is not used. See General Regulations 10:10.

SECTION 4C

E.T. MOTORCYCLE

7.50 (*4.50) seconds & slower

DESIGNATION

ET/MC, preceded by rider number. For motorcycles running 7.50 (*4.50) seconds or slower. Unaltered OEM production Can-Am Spyder three-wheel motorcycle permitted. All other three-wheel vehicles prohibited.

Competition structure will be conducted in an e.t. dial-your-own format. Competition with snowmobiles and other types of vehicles permitted.

Data recorders are permitted in Advanced E.T. and Super Pro only. Data recorders (except for "playback"-type tachometers) are prohibited in all other E.T. classes.

Computers (except for OEM) are prohibited in all E.T. brackets.

REQUIREMENTS & SPECIFICATIONS

ENGINE: 1

ENGINE

Must be stock-type engine specifically designed and manufactured for production motorcycle use. Snowmobile engines, single cylinder Jr. Dragster engines permitted. Automobile, aircraft, or marine engines prohibited. All engines must be self-starting; push or roller starts prohibited.

EXHAUST

Exhaust must be directed away from rider when in riding position.

FUEL

Racing gasoline, gasoline, gasohol, methanol, propane, natural gas, and ethanol permitted. Nitromethane prohibited.

FUEL SYSTEM

Fuel-shutoff valve mandatory.

INDUCTION

Electronic fuel injection permitted. Any induction permitted. Open-loop systems permitted on production motorcycles as equipped with OEM electronic fuel injection. See General Regulations 9:1, 9:11.

NITROUS OXIDE

Commercially available nitrous oxide permitted. Bottles must be stamped with a DOT-1800 pound rating and permanently mounted (no hose clamps or tie wraps). Hoses from bottle(s) to solenoid must be high-pressure steel-braided or NHRA-accepted hoses. Commercially available, thermostatically controlled, blanket-type warmer accepted. The use of torch or any other external heating of bottle(s) prohibited.

SUPERCHARGER/TURBOCHARGER

Permitted.

DRIVETRAIN: 2

CHAIN AND/OR BELT GUARDS

Mandatory. Must have front and rear chain guards to cover the width and at least the top run to the centerline of the sprocket of any chains or belts. The clutch assembly must have at least

half of the side surface covered. The guards should be .060-inch steel or 1/8-inch aluminum unless otherwise stock equipped and be securely mounted.

BRAKES & SUSPENSION: 3

BRAKES

Operational front and rear brakes mandatory. Drilled disc brakes may be used if commercially manufactured or they meet the following requirements:

- A. The original diameter must be maintained.
- B. Minimum thickness: 3/16-inch.
- C. Maximum hole size: 1/2-inch with all holes countersunk.
- D. No two holes closer than 1 1/4 inches, center to center.
- E. Mechanical front disc brakes permitted in all classes.

CONTROLS

Handlebars must measure at least 22 inches overall with the grips removed. Snap-back throttle mandatory. Brake pedals must remain stock. Any shifter that can be operated from the foot-peg location with the foot on the peg will be permitted. Hand operation of the foot shifter prohibited; both hands must remain on the handlebars at all times. After leaving starting line the rider's feet must remain on the pegs. Electronic throttle stops and/or shifters permitted.

SUSPENSION

Front suspension must have a minimum of 1 1/2 inches of travel. Bolt on tie-down permitted on street legal motorcycle, without wheelie bars, only. Steering dampener permitted.

WHEELIE BARS

Optional. Maximum length may be equal to, but may not exceed, the wheelbase of the motorcycle. Wheelie-bar length is measured from center of rear axle to center of wheelie-bar wheel.

FRAME: 4

FRAME

Must be motorcycle type. Scooters, mopeds, bicycle parts prohibited.

GROUND CLEARANCE

Minimum 2 inches.

TIRES & WHEELS: 5

TIRES

Automotive tires permitted. See General Regulations 5:1.

WHEELS

Automotive wheels permitted. Wheel studs on automotive-type wheels must project into hex part of lug nut by at least one diameter of the stud. See General Regulations 5:2.

BODY: 7

REAR FENDER

Rear fender must cover the full width of the rear tire and extend behind the rear axle and forward below seat position.

ELECTRICAL: 8

IGNITION

Timed ignition-interruption devices (stutter boxes) prohibited. Starting-line and/or "high-side" rev limiters permitted. Two-steps, rev limiters, or any other rpm-limiting devices, legal unto themselves but altered or installed so as to function as a down-track rpm controller, prohibited. See General Regulations 8:1, 8:3, 8:4, 8:5.

IGNITION SHUTOFF

Motorcycles 10.99 (*6.99) seconds or quicker must be equipped with a positive ignition cutoff switch attached to the rider with a lanyard. OEM cutoff permitted in place of lanyard. Switch must be on low-voltage side of the ignition circuit. Many stock machines are equipped with a handlebar-mounted thumb switch that can have a lanyard easily attached for the above purpose.

STARTER

All engines must be self-starting; plug-in electric starters permitted. Push or roller starts prohibited.

TAILLIGHT

One functional taillight mandatory. See General Regulations 8:6.

SUPPORT GROUP: 9**COMPUTER/DATA RECORDER**

NHRA-accepted data loggers permitted, where allowed by class rules. See General Regulations 9:1, 9:2.

PRESSURIZED BOTTLES

Any pressurized container must be stamped with DOT-1800 pound rating and be securely mounted. Swing arm may be pressurized, maximum pressure 150psi. Gauge must be installed to monitor pressure. See General Regulations 9:8.

RIDER: 10**CREDENTIALS**

Valid NHRA competition license mandatory for riders of all motorcycles running 9.99 (*6.39) or quicker. Valid state- or government-issued driver's license beyond a learner's-permit level mandatory for riders of motorcycles 10.00 (*6.40) or slower. See General Regulations 10:4.

HELMET

Full-face Snell M2010, M2015, SA2010, or SA2015 helmet mandatory; shield mandatory (goggles prohibited). See General Regulations 10:7.

PROTECTIVE CLOTHING

Full all-leathers or SFI Spec 40.1/2 suit mandatory on motorcycles running 120 mph or faster. Two-piece suits must be joined together with a metal 360-degree zipper at the waist. SFI Spec 40.1/1 or 40.1/2 suit or leather jacket, leather boots/shoes above the ankle, and leather gloves are mandatory on ALL motorcycles. Gloves must be Kevlar-lined or equipped with slide buttons. See General Regulations 10:10.

SECTION 4D

ADVANCED E.T. MOTORCYCLE

6.00 (*3.66) to 7.49 (*4.49) seconds

Requirements and specifications for Advanced E.T. Motorcycle are the same as those for E.T. Motorcycle - Section 4C - with the following exceptions:

DESIGNATION

AD/MC, preceded by competition number.

For motorcycles running between 7.49 (*4.49) and 6.00 (*3.66) seconds. Handicapped start utilizing full Tree or Pro start.

REQUIREMENTS & SPECIFICATIONS

BRAKES & SUSPENSION: 3

BRAKES

Hydraulic brakes, front and rear, mandatory. Minimum sizes: front, 9-inch diameter x 1/8-inch width for dual rotors, 11-inch diameter x 3/16-inch width for single rotor. Rear, 10-inch diameter x 3/16-inch width. Steel-braided brake lines mandatory.

RIDER: 10

CREDENTIALS

Valid NHRA competition license mandatory: Class 2, Type D.

SECTION 4E

E.T. SNOWMOBILE

7.50 (*4.50) seconds & slower

DESIGNATION

SM, preceded by competition number.

For snowmobiles running 7.50 (*4.50) and slower. All snowmobiles must be factory-production assembled, showroom available, and in the hands of the general public.

Competition structure will be conducted in an e.t. dial-your-own format. Competition with motorcycles and other types of vehicles permitted.

Data recorders are permitted in Advanced E.T. and Super Pro only. Data recorders (except for "playback"-type tachometers) are prohibited in all other E.T. classes.

Computers (except for OEM) are prohibited in all E.T. brackets.

REQUIREMENTS & SPECIFICATIONS

ENGINE: 1

ENGINE

Must be specifically designed and manufactured for production

snowmobile or personal watercraft use. Engine modifications permitted. Automobile, motorcycle, or aircraft engines prohibited.

COOLING SYSTEM

Quick-disconnect system permitted.

EXHAUST

Any functionally silenced exhaust permitted. Exhaust-system emission pipe must not protrude more than 3 inches beyond the chassis or hood. Exhaust-gas-temperature gauge permitted; may connect to exhaust system only.

FUEL

Racing gasoline, gasoline, and methanol permitted. Nitromethane prohibited.

NITROUS OXIDE

Commercially available nitrous oxide permitted. Bottles must be stamped with a DOT-1800 pound rating and permanently mounted (no hose clamps or tie wraps). Hoses from bottle(s) to solenoid must be high-pressure steel-braided or NHRA-accepted hoses. Commercially available, thermostatically controlled, blanket-type warmer accepted. The use of a torch or any other external heating of bottle(s) prohibited.

SUPERCHARGER/TURBOCHARGER

OEM permitted. Aftermarket prohibited except in eighth-mile.

THROTTLE

Throttle must be located in OEM location and must operate in OEM configuration.

DRIVETRAIN: 2

CLUTCH

Must be specifically designed and manufactured for snowmobile use.

Chains, pulleys, belts, and exposed moving parts must be isolated from the driver and other competitors by securely mounted shield(s) capable of retaining all accidental explosions and component impacts. No holes may be drilled in protective shields.

OEM clutch covers/guards are permitted only when the unmodified OEM engine (or unmodified factory designated replacement) is used.

Modified engines require a clutch cover/guard that provides 360-degree elliptical coverage in the direction of clutch/belt travel. The clutch cover/guard must be minimum .090-inch 2024T3, 6061T6, or 7075T6 aluminum or .060-inch steel and be covered with securely fastened, 6-inch-wide, industrial-type belt. Belting material must be minimum 1/8-inch thick and minimum two-ply construction, with at least one side rubber-coated. Clutch cover/guard constructed of minimum .125-inch 2024T3, 6061T6, or 7075T6 aluminum or minimum .090-inch steel are exempt from the belting-cover requirement. Snowmobiles with bolted/removable side panels may have clutch cover/guard bolted to side panels. Clutch cover/guard must be separate from the cowl.

DRIVE TRACK

Track must be of a flat-type configuration. Paddles, studs, and/or spikes prohibited. Track must be OEM, OEM replacement, or NHRA-accepted aftermarket specifically designed for asphalt competition. All snowmobiles 9.99 seconds or quicker must use aftermarket asphalt competition track. Track lubrication systems

prohibited. Track must be free of visible signs of excessive wear. Manufacturer's logo and serial number must be retained and appear on left side of aftermarket competition tracks.

SKID FRAME

Skid frame must maintain OEM width. Wheels may be removed.

SKIS AND WHEELS

All drive and steering wheels must be of a rubber specifically designed for snowmobile use on a dry surface and installed so as to keep skis from coming in contact with racing surface. Maximum four wheels per ski permitted. Carbides prohibited. All skis must be OEM steel or aftermarket aluminum or steel. Aftermarket skis must be constructed according to the following minimum standards. Square angles on the side plate at the front of the ski are prohibited; must have beveled edge. See illustration.

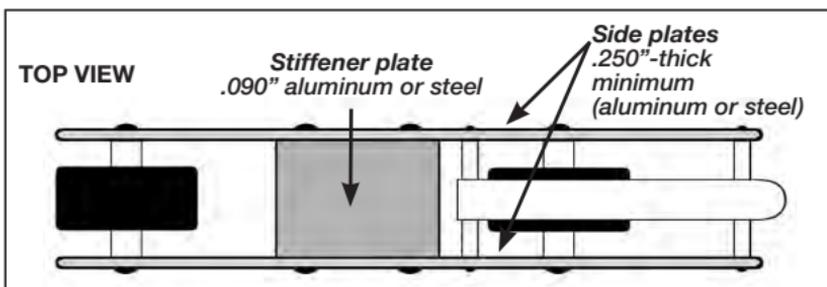
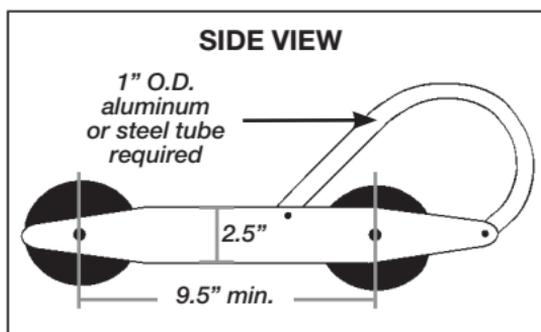

BRAKES & SUSPENSION: 3

BRAKES

Must be OEM type. Any additional assembly must be added onto the drive axle shaft. Axle shaft may be lengthened to accommodate the additional brake.

SUSPENSION

All snowmobiles must have a minimum 1 inch of travel in the track suspension. Only steel springs will be permitted. Externally activated suspension systems prohibited. Hyfax must be removed. Bogie wheels must be used on each side of the rear suspension to prohibit the slide rails from coming in contact with the rubber track surface. Use of any external slide-rail lubrication system prohibited. Steel coilover or leaf spring permitted.

CHASSIS: 4

CHASSIS

Chassis must be OEM stock qualified. Any modifications that alter the stock appearance of the tunnel are prohibited.

FUEL TANK

Aftermarket fuel tank may replace OEM fuel tank. Oil injection tank may be used as fuel tank. OEM appearance of snowmobile must be retained. Pressurized fuel tank prohibited.

SNOW FLAP

All snowmobiles must be equipped with an OEM rear snow flap for the specific model, fastened to the tunnel in a manner that prohibits the snow flap from being drawn into the rear tunnel enclosure (a simple W-shaped bracket fixed to the upper portion of the rear tunnel stops this).

BODY: 7**AIR DAMS, AIR FOILS, WINGS**

Frontal air dam permitted, vertical or rounded. Air dams or air foils may not extend forward of or outside of OEM body or engine cover. Must maintain 3 inches ground clearance. Fins or other forward protrusions prohibited.

WINDSHIELD

OEM-style windshield required.

WINGS

Prohibited.

ELECTRICAL: 8**IGNITION**

Timed ignition-interruption devices (stutter boxes) prohibited. Starting-line and/or "high-side" rev limiters permitted. Two-steps, rev limiters, or any other rpm-limiting devices, legal unto themselves but altered or installed so as to function as a downtrack rpm controller, prohibited. See General Regulations 8:2, 8:3, 8:5.

IGNITION SHUTOFF

Must be equipped with a positive ignition-cutoff switch, capable of de-energizing entire ignition system, attached to rider with a lanyard.

TAILLIGHT

One functional taillight mandatory. See General Regulations 8:6.

SUPPORT GROUP: 9**PARACHUTE**

Prohibited.

PRESSURIZED CONTAINERS

Prohibited.

BACKSTANDS

A clean-out procedure may be performed only on an accepted backstand. Backstand may not have any brushing or cleaning attachment that is used to brush or clean a rotating track. Track may be cleaned only by manual rotation. Cutoff lanyard must be attached to rider and machine anytime snowmobile is started and/or running.

RIDER: 10**CREDENTIALS**

Valid NHRA competition license mandatory for riders running 9.99 (*6.39) or quicker. Valid state- or government-issued driver's license beyond a learner's-permit level mandatory for riders 10.00 (*6.40) or slower. See General Regulations 10:4.

HELMET

Full-face Snell M2010, M2015, SA2010, or SA2015 helmet mandatory; shield mandatory (goggles prohibited). See General Regulations 10:7.

PROTECTIVE CLOTHING

Full all-leathers or SFI Spec 40.1/2 suit mandatory for snowmobiles running 120 mph or faster. Two-piece suits must be joined at the waist with a metal 360-degree zipper. Jacket and pants or suit meeting SFI Spec 40.1/1 or 40.1/2 (or leather jacket), leather boots/shoes above the ankle, and leather gloves mandatory. Gloves must be Kevlar-lined or equipped with slide buttons. See General Regulations 10:10.

SECTION 4F

ALL-TERRAIN VEHICLE

7.50 (*4.50) seconds & slower

DESIGNATION

ATV, preceded by competition number.

For All-Terrain Vehicles (ATVs) running directly on the track surface. All ATVs must be of the four-wheel variety, factory-production assembled, showroom available, and in the hands of the general public. No three-wheel vehicles allowed.

Competition structure will be conducted on an E.T. dial-your-own format. Competition with motorcycles and snowmobiles permitted. Competition with any other type of vehicle prohibited.

Data recorders are permitted in Advanced E.T. and Super Pro only. Data recorders (except for "playback"-type tachometers) are prohibited in all other E.T. classes.

Computers (except for OEM) are prohibited in all E.T. brackets.

REQUIREMENTS & SPECIFICATIONS

ENGINE: 1

ENGINE

Must be OEM produced and built for ATV use. Automotive or aircraft engines prohibited.

EXHAUST

Any functionally silenced exhaust permitted. Exhaust must be directed away from rider when in riding position.

FUEL

Gasoline, methanol, or racing gasoline only. Nitromethane and/or nitrous oxide prohibited.

THROTTLE

Throttle must be located in OEM location and must operate in OEM configuration.

DRIVETRAIN: 2

CHAIN AND/OR BELT GUARDS

Modified engines require a clutch guard that provides coverage in the direction of chain travel. Must have front and rear chain guards to cover the width and at least the top run to the centerline of the sprocket of any chains or belts. The clutch assembly must have at least half of the side surface covered. The guards should be .060-inch steel or 1/8-inch aluminum unless otherwise stock equipped and be securely mounted.

BRAKES & SUSPENSION: 3

BRAKES

Must be OEM type. Any additional assembly must be added onto the drive axle shaft. Axle shaft may be lengthened to accommodate the additional brake.

SUSPENSION

Shocks and spring may be changed, must maintain OEM configuration.

WHEELIE BARS

Optional. Maximum length may be equal to, but may not exceed, the wheelbase of the All-Terrain Vehicle. Wheelie-bar

length is measured from center of rear axle to center of wheelie-bar wheel.

CHASSIS: 4

CHASSIS

Chassis/frame must be OEM stock qualified. Maximum wheelbase 60 inches, measured from centerline of front hub to centerline of rear hub. Any modifications that alter the stock appearance of the tunnel are prohibited.

FUEL TANK

Aftermarket fuel tank may replace OEM fuel tank. OEM appearance of All-Terrain Vehicle must be retained. Pressurized fuel tank prohibited.

TIRES & WHEELS: 5

TIRES

Stock off-road tires permitted for eighth-mile competition only. Stiff sidewall street tires must be installed for quarter-mile application.

WHEELS

Automotive wheels permitted.

BODY: 7

AIR DAMS, AIR FOILS

Air dams, streamlining equipment, spoilers, fairings, or frontal projections prohibited.

WINGS

Prohibited.

ELECTRICAL: 8

IGNITION

Timed ignition-interruption devices (stutter boxes) prohibited. Starting-line and/or "high-side" rev limiters permitted. Two-steps, rev limiters, or any other rpm-limiting devices, legal unto themselves but altered or installed so as to function as a down-track rpm controller, prohibited. See General Regulations 8:2, 8:3, 8:5.

IGNITION SHUTOFF

Must be equipped with a positive ignition-cutoff switch, capable of de-energizing entire ignition system, attached to rider with a lanyard.

TAILLIGHT

One functional taillight mandatory. See General Regulations 8:6.

SUPPORT GROUP: 9

PARACHUTE

Prohibited.

RIDER: 10

CREDENTIALS

Valid NHRA competition license mandatory for riders running 9.99 (*6.39) or quicker. Valid state- or government-issued driver's license beyond a learner's-permit level mandatory for riders 10.00 (*6.40) or slower. See General Regulations 10:4.

HELMET

Full-face Snell M2010, M2015, SA2010, or SA2015 helmet mandatory; shield mandatory (goggles prohibited). See General Regulations 10:7.

PROTECTIVE CLOTHING

Full all-leather or SFI Spec 40.1/2 suit mandatory for All-Terrain Vehicles running 120 mph or faster. Two-piece suits must be joined at the waist with a metal 360-degree zipper. Jacket and pants or suit meeting SFI Spec 40.1/1 or 40.1/2 (or leather jacket), leather boots/shoes above the ankle, and leather gloves mandatory. Gloves must be Kevlar-lined or equipped with slide buttons. See General Regulations 10:10.

SECTION 4G

ELECTRIC-POWERED VEHICLE

7.50 (*4.50) seconds & slower

Requirements and specifications for Electric-Powered Vehicle are the same as those for E.T. bracket vehicles - Section 4A - with the following exceptions:

REQUIREMENTS & SPECIFICATIONS

MOTOR: 1

MOTOR

Electric motor(s) only permitted. Maximum height of electric-motor output-shaft centerline: 36 inches on OEM trucks, 24 inches on all others. Vehicles with exposed motors must have a shield of .024-inch steel, .032-inch aluminum, or .120-inch Lexan.

FUEL SYSTEM

All conversion vehicles must remove fuel tanks and fuel system, including vapor storage equipment, from vehicle.

DRIVETRAIN: 2

CLUTCH, FLYWHEEL, FLYWHEEL SHIELD

Flywheel and clutch meeting SFI Spec 1.1 or 1.2 (two-disc maximum) mandatory on any car running 11.49 (*7.35) or quicker. Flywheel shield meeting SFI Spec 6.1, 6.2, or 6.3 mandatory on all cars running 11.49 (*7.35) or quicker. Exposed-motor electric-powered vehicles with open-frame, vented, or brush replacement window motors must install a motor shield, minimum .024-inch steel or .032-inch aluminum, 360 degrees to provide protection from flying commutator bars, molten copper, plasma, etc. in event of motor overload. A motor plate, minimum 1/4-inch steel or 1/2-inch aluminum, may be used to adapt traction motor to conventional transmission.

DRIVELINE

Driveline loop mandatory on any non-OEM vehicle running 16.00 seconds or quicker. See General Regulations 2:4, 2:11.

REAR END

Chain-drive vehicles must be equipped with a chain guard constructed with minimum .125-inch steel or .250-inch aluminum, covering width and top run of chain to centerline of sprockets.

BRAKES & SUSPENSION: 3

SUSPENSION, STOCK-BODIED VEHICLES

OEM three-wheeled vehicles permitted.

FRAME: 4**DEFLECTOR PLATE, OPEN-BODIED VEHICLES**

Each vehicle must have protection for driver from traction motor overload. Must protect driver from motor plasma, flying commutator bars, molten copper, bursting batteries, and spraying electrolyte.

WHEELBASE

Minimum 90 inches, unless car has original motor or is a conversion electric-powered vehicle with motor in original (internal-combustion) location. For vehicles with a wheelbase shorter than 90 inches but greater than 40 inches, vehicle cannot exceed 50 mph at any point on the racetrack.

ELECTRICAL: 8**BATTERIES**

Must be securely mounted and outside driver compartment. Batteries must be installed so as to withstand a force four times (vertical) and eight times (horizontal) the weight of the battery pack, and each battery or battery pack must be secured with bolts and straps commensurate with the size and weight of the battery. (Contact NHRA for requirements.) Battery may not be located above the top of rear or drive tires in open-wheeled cars, nor outside body lines in bodied car, except for OEM-production-line electric-powered vehicles. Battery(s) must be completely sealed from driver compartment. All open-bodied vehicles must use ABSORBED GLASS MAT, STARVED ELECTROLYTE, or SEALED VENTED NICAD batteries for power source. Traction-motor and/or high-current wiring may not be located in driver's compartment. Instrumentation wiring permitted. All traction-motor wiring must be isolated from vehicle chassis.

Battery on flat plate with strap only		Battery in rack/box or with cleats	
Bolt size	Battery weight	Bolt size	Battery weight
#8	6	#8	15
#10	7.5	#10	19
1/4	14	1/4	35
5/16	23	5/16	57
3/8	34	3/8	83
7/16	46	7/16	114
1/2	61	1/2	152
9/16	78	9/16	195
5/8	96	5/8	243

FUSING OF BATTERIES

All battery packs must have over-current protection. Circuit breaker(s) or fuse(s) permitted. Such protection devices must have a DC voltage rating equal to or greater than the nominal pack voltage. Current rating must be lower than a short-circuit current that pack can produce without damage. Battery sub-packs must be individually fused.

RECHARGING

Batteries may be recharged in pits or other designated areas only. All vehicles must be connected to AC power-supply (earth) ground when charging. All battery chargers must be equipped with an output fuse rated for 600 volts and a current capacity at least 125 percent of maximum charger DC output.

IGNITION

All vehicles must have a visible indication of a "live" car, except OEM. An externally activated switch or switch control must be installed on the outside of the vehicle and clearly marked to indicate OFF position. A RED triangle must be clearly visible whenever power system is turned ON. This may be a light or a mechanical indicator. Traction battery pack must be physically disconnected when switch is in the OFF position.

MASTER CUTOFF

All vehicles except OEM must incorporate a master electrical disconnect switch that must disable all electrical functions. Switch must disconnect traction-motor battery-pack section of the circuit, and if the switch is a push-pull design, push motion must be "off" function.

WIRING

All high-voltage wiring must be located and secured to prevent contact by driver and/or spectators. Any wiring with voltage higher than 24 volts must be completely covered.

SECTION 4H ELECTRIC-POWERED MOTORCYCLE

7.50 (*4.50) seconds & slower

Requirements and specifications for Electric-Powered Motorcycle are the same as those for E.T. Motorcycle - Section 4C - and Electric-Powered Vehicle - Section 4G - with the following exceptions:

REQUIREMENTS & SPECIFICATIONS

MOTOR: 1

MOTOR

Electric motor(s) only permitted.

ELECTRICAL: 8

BATTERIES

Wet (free-liquid) battery prohibited.

MASTER CUTOFF

All electric motorcycles must be equipped with a switch, attached to rider with a lanyard, capable of shutting off all power to electric traction motor.

SECTION 4I LEGEND CARS

See NHRA Exhibition Rulebook for rules.



SECTION 5

MICKEY THOMPSON TIRES NHRA TOP FUEL HARLEY DRAG RACING SERIES

DESIGNATION

TFH, followed by motorcycle number.

Reserved for nitro burning motorcycles. Built specifically for all out drag racing.

REQUIREMENTS AND SPECIFICATIONS

ENGINE: 1

ENGINE

Must keep design features of Harley-Davidson engines (Pushrod, 45° to 90° VTwin). Carbureted, fuel injected or supercharged single or double engines with 200 cubic inch maximum displacement. Pushrod aftermarket heads are permitted (including 4 valve). Crankcase and all tanks containing fluids must have vent tubes routed to catch can or have a non-spill breather system on motorcycle. Superchargers must have rubber manifold connections or some form of "sneeze" valve. Supercharger blankets are mandatory. Must have "Bellypan" scatter shield under engine. S.F.I. Specification 46.1 approved engine restraint systems are required. A nonflammable, oil absorbent liner mandatory inside of retention device. These restraints must be replaced or recertified by the manufacturer every two (2) years. Chest protectors are mandatory.

FUEL

Fuel to be mononitromethane and/or methyl alcohol only. No propylene oxide or nitrous permitted. Refer to General Regulations Section 1:6 of the current NHRA Rulebook for nitromethane regulations.

DRIVETRAIN: 2

CHAIN GUARD

Mandatory on all motorcycles. Chain guard must be .060-inch steel or 1/8-inch aluminum and must be securely mounted in three places. Chain guard must cover the width and at least the top run of the chain, from centerline to centerline of sprockets.

CLUTCH

Any type dry friction clutch, including multi-stage setup, permitted. Clutch engagement must be by centrifugal force only

and must exhibit reliable disengagement at idle speed. Clutch must have a protective guard made of .060-inch steel or 1/8-inch aluminum that covers the unit 360 degrees.

TRANSMISSION

Any transmission or high-gear-only system may be used.

BRAKES AND SUSPENSION: 3

BRAKES

Hydraulic type, front and rear, mandatory. Minimum size for dual rotor is 9-inch diameter, 1/8-inch thickness for rotors. Single rotor must be over 11-inch diameter.

CONTROLS

Handlebar controls must be located in safe, workable position. Foot pegs and foot controls must be located in safe, workable position and must be mounted in a safe, craftsman-like manner. Rider must be able to shut off fuel without removing hands from handlebars. A secondary shut-off device attached to rider (in the event of premature exit from motorcycle) must mechanically control the fuel shut-off valve. Lanyard for shut-off must be run through an eyelet or guide, allowing the lanyard to be pulled in any direction and closing shut-off. Dual cable push-pull throttle assembly is mandatory.

SUSPENSION

Front suspension minimum size 32 mm and minimum travel of 2 inches. A steering dampener is mandatory. Rear suspension not required. Fork stops required; must limit the turning arc to 28 degrees.

FRAME: 4

FRAME

Any type permitted. All frames should be heliarc welded and main rails must be chrome moly and have a minimum diameter of 1-1/8 inch. All major frame tubing must have at least .065-inch wall thickness. Rake angle must be at least 40 degrees. Alternative frame materials must be submitted to NHRA for approval. Frames constructed before 1999 and approved for competition may use one (1) x .058 inch tubing.

GROUND CLEARANCE

Minimum of 2 inches with rider on motorcycle and 10 p.s.i. in rear tire (includes exhaust and kickstand).

PARACHUTE

Mandatory. See General Regulations 4:8

WHEELBASE

Minimum of 85 inches.

WHEELIE BARS

Wheelie bars are required. Minimum length from center of rear axle to center of wheelie bar axle must be at least 84 inches but not exceed 120 inches. Must be securely cross-braced.

TIRES AND WHEELS: 5

TIRES

Must be specified for racing use by manufacturer. Any tire size is permitted

WHEELS

Rear wheel minimum 15 inch, maximum 18 inch. Front wheel minimum 16 inch, maximum 19 inch.

SEAT: 6

SEAT

Seat, tail section and rear fender may be incorporated into one unit and must include a step to prevent rider sliding backward.

BODY: 7**BODY**

No body parts are required, except rear fender that must cover width of tire and extend past the rear axle.

FAIRING

Permitted. Must be mounted solidly to frame tubes.

ELECTRICAL: 8**IGNITION**

Any ignition system is permitted.

CHARGING SYSTEM

Not required.

STARTING SYSTEM

Must be electric external starter. Battery top covers are required. No rollers. No push starts. Jack stands are mandatory for starting. No dry hops in pits.

CONTROL SWITCHES

Must be mounted and constructed in an accepted manner. Must have an emergency fuel shut off.

LIGHTS

Not required.

SUPPORT GROUP: 9**COMPUTER/DATA RECORDERS**

Only data gathering computers are permitted.

SHUTOFF DEVICE

Electrimotion Pro Stock Shutoff Controller Kit (RF001PS) mandatory. The Electrimotion Pro Stock Shutoff Controller Kit must be properly installed per the manufacturer's instructions. Modification or tampering with the Electrimotion Pro Stock Shutoff Controller Kit prohibited.

RIDER: 10**CREDENTIALS**

Valid NHRA competition license mandatory for riders of all motorcycles running 9.99 (*6.39) or quicker. Valid state- or government-issued driver's license beyond a learner's-permit level mandatory for riders of motorcycles 10.00 (*6.40) or slower. See General Regulations 10:4 in NHRA Rulebook.

HELMET

Full-face Snell M2010, M2015, SA2010 or SA2015 helmet mandatory; shield mandatory (goggles prohibited). Eject Helmet Removal System (part number SDR 890-01-30) mandatory and must be installed per manufacturer instructions. A Stand 21 Lid Lifter head sock meeting SFI 3.3 may be used in lieu of the Eject Helmet Removal System. See General Regulations 10:7.

PROTECTIVE CLOTHING

Full all-leathers or SFI Spec 40.1/2 suit, leather boots that completely cover the ankle with toe-area reinforcement, and full-finger leather gloves are mandatory. Gloves must be Kevlar-lined or equipped with slide buttons and have knuckle armor and palm reinforcement. Suits may be one-piece design or joined with a zipper at the waist. Reinforcement and/or armor in the knee, elbow, shoulder, and knuckle areas required. Spine/back protector and ballistic chest protector mandatory.

RACE TEAM CLOTHING

All team crewman that help start, assist in burnout and stage race motorcycle must wear a uniform shirt that relates to their specific team.



SECTION 6 E3 SPARK PLUGS NHRA PRO MOD DRAG RACING SERIES PRESENTED BY J&A SERVICE

DESIGNATION

PM, preceded by car number. Classes of competition within Pro Modified are for supercharged, methanol-burning, turbocharged methanol or gasoline-burning, or nitrous-assisted, gasoline-burning full-bodied cars.

Minimum weight at the conclusion of run, including driver:

Nitrous-assisted entries (910 cid) - 2,425 pounds

Nitrous-assisted entries with lock-up converter (910 cid) - 2,450 pounds

Supercharged entries (526 cid) - 2,600 pounds

Turbocharged entries (526 cid) - 2,650 pounds

Nostalgia body styles (1937-1938 Chevy, 1941 Willys, 1953 Studebaker, 1953-1962 Corvette and 1955-1957 Chevy and Buick) may deduct 50 pounds from minimum weight.

NHRA reserves the right to amend rules as performance dictates. Any competitor who causes an oiltdown while participating at an NHRA Mello Yello event will be subject to fines and penalties as outlined in Section 2 – Oiltdown Penalties.

REQUIREMENTS & SPECIFICATIONS

ENGINE: 1

COOLING SYSTEM

Radiator permitted. Electrically driven fan and water pump permitted.

CYLINDER HEADS

Hemi, canted-valve, or wedge heads permitted. Billet heads permitted. Maximum one spark plug per cylinder. Maximum two valves per cylinder. Maximum supercharged valve sizes: intake 2.400 inches; exhaust 1.900 inches. Maximum turbocharged valve sizes: intake 2.450 inches; exhaust 1.900 inches.

ENGINE

Internal-combustion, reciprocating, single-camshaft, 90-degree V-8 automotive-type engine mandatory. Crankshaft centerline must intersect cylinder bore centerlines and be symmetrical. Nitrous-assisted entries are limited to a maximum bore center of 5.300. Maximum bore center on turbocharged billet hemi cylinder-head entries is 4.800 inches, 5.000 inches on all other turbocharged entries. Maximum bore center on supercharged billet hemi cylinder-head entries is 4.900 inches, 5.000 inches on all other super charged entries. For supercharged entries, a positive method (flange, lip, etc.) must be attached to the intake manifold or engine block to retain both the front and rear manifold to block gaskets in the event the engine crankcase/lifter valley becomes over-pressurized. The flange/lip must extend past the surface of the gasket and be contoured to closely fit the block and manifold surfaces to prevent the gasket(s) from extruding. See General Regulations 1:2.

ENGINE SETBACK

Maximum engine setback limited to 10 percent of wheelbase as measured from centerline of front spindle to center of front sparkplug hole.

EXHAUST SYSTEM

Competition exhaust systems permitted. Exhaust must be directed out of body to rear, away from driver and fuel tank. See General Regulations 1:3.

FUEL

NHRA-accepted racing gasoline or methanol permitted. A current list of NHRA-accepted fuels is available on NHRARacer.com. The use of propylene oxide is prohibited. See General Regulations 1:6.

FUEL SYSTEM

Fuel cell/tank must have pressure cap and be vented to outside of body. Where fuel cells are used they must meet SFI Spec 28.1. Fuel cells/tanks must be mounted between framrails and enclosed in a round tube frame, minimum 1 1/4-inch O.D. x .065-inch chromoly tubing. Extra tank(s) prohibited. Artificial cooling or heating systems (i.e., cool cans, ice, Freon, etc.) prohibited. Circulating systems, not part of normal fuel-pump system, prohibited. Minimum temperature of fuel in the staging lanes to the completion of the run and subsequent NHRA fuel check is 50 degrees F. A failure to pass the minimum fuel-temperature check in the staging lanes prior to a run will result in the forfeiture of that run, and the racer must return to the racer's pit. A failure to pass the minimum fuel-temperature check after a run will cause that run to be disqualified. Water injection permitted on nitrous entries only; only water permitted in water injection system. See General Regulations 1:5.

INDUCTION

Any number and type of carburetors or throttle bodies may be used. Electronic fuel injection permitted. See General Regulations 9:1, 9:11.

INTAKE MANIFOLD

A burst panel is mandatory on all entries. Supercharged and turbocharged entries must have a manifold burst panel meeting SFI Spec 23.1. Nitrous-assisted entries must have an NHRA-

accepted intake restraint system. A current list of NHRA-accepted intake restraint systems is available on NHRARacer.com.

LOWER ENGINE CONTAINMENT DEVICE/OIL PAN

All entries must be equipped with a properly fitting lower-engine ballistic/restraint device meeting SFI Spec 7.1. An engine-oil-retention pan is mandatory. Minimum material size is .050-inch aluminum or .040-inch carbon fiber/Kevlar. Engine-oil-retention pan must run from in front of the front motor plate to in front of rear motor plate and to just inside or outside of the lower framereils. Engine-oil-retention walls must be a minimum of 2 inches tall. Front and rear walls must be "coved" toward oil pan a minimum of 1/2-inch to assist oil in staying within the confines of the oil-retention device. A non-flammable, oil-absorbent material is mandatory inside of retention device. See General Regulations 1:8.

NITROUS OXIDE

Prohibited on supercharged and turbocharged entries. No bottle may be turned on until after burnout is completed. No inline valves accepted as bottle shutoff in staging lanes. Push systems accepted. A Hobbs switch is mandatory and must be installed so that the nitrous system may only be activated when there is sufficient fuel pressure. Nitrous system must be activated by a wide-open throttle switch. All nitrous bottles must be stamped as meeting minimum DOT-1800 pound rating. Maximum of two bottles, fifteen pounds per bottle. Commercially available, thermostatically controlled, blanket-type warmer accepted. The use of a torch or any other external heating of bottle(s) prohibited.

OIL SYSTEM

All pressurized flexible oil lines must pass a minimum 750 psi 30 second test and be tagged to indicate successful testing. See General Regulations 1:9.

SUPERCHARGER

Screw-type and centrifugal-type superchargers prohibited. Hi-helix or standard helix Roots-type supercharger only. Supercharger restraint system meeting SFI Spec 14.2, including injector restraint straps mandatory. Cast or billet cases permitted. Maximum supercharger overdrive limit is 16.5 percent on all combinations. Intercoolers, variable multi-speed supercharger devices prohibited. The top opening of the supercharger may not exceed 12 inches in length or 5 inches in width. The entire inlet opening must be on/in the upper surface only. The maximum length from the front of the supercharger drive pulley to the leading edge of the rotor is 15 inches. Offset drive pulleys, spacers, modified cases, or attaching methods may not be used to add to the 15-inch maximum. All manifold configurations, supercharger modifications and locations must be accepted prior to competition. The rotors must be driven from the front (both the external drive and the internal gearing. Any inlet/outlet cavity in front of the rotors is restricted to a maximum of 3.000 inches measuring from the face of the bearing plate to the front of the cavity. Supercharger openings must be fixed from the water box until the conclusion of the run. See General Regulations 1:10, 1:11.

THROTTLE

Throttle control must be manually operated by driver's foot. Electronics, pneumatics, or hydraulics is permitted for starting line/staging rpm limiters only. See General Regulations 1:12.

TURBOCHARGER

Twin turbochargers limited to 88mm each. Turbocharger size will be verified by measuring the housing bore at the leading edge of the impeller wheel. The maximum diameter of the housing bore

at the leading edge of the wheel may not exceed 2mm more than the maximum allowable turbocharger size permitted. All turbochargers must meet SFI Spec 61.1. Air-to-air or water-to-air intercoolers prohibited.

Boost controller manufactured by Hyperaktive Performance Solutions, part No. PMBL mandatory. No other boost controller or form of boost control permitted. Must be installed per manufacturer's instructions as documented on NHRARacer.com: NHRA Accepted Products, NHRA Accepted Product Specifications, Pro Mod, Hyperkontrol Boost System Installation and Operation Manual. Any modification to or any attempt to disable or defeat the boost controller is prohibited. Any attempt to corrupt or delete data associated with the boost controller is prohibited. Maximum boost may only be set by NHRA officials.

Boost Pressure Limit: 36 psi

VENT TUBES

All tubing material must be flame resistant. See General Regulations 1:13.

DRIVETRAIN: 2

CLUTCH, FLYWHEEL, FLYWHEEL SHIELD & MOTOR PLATE

Flywheel and clutch must meet either SFI Spec 1.3, 1.4, or 1.5. Three discs maximum with a maximum disc diameter of 11 inches or four discs maximum with a maximum disc diameter of 8 inches. Flywheel shield meeting SFI Spec 6.2 or 6.3 mandatory. Maximum depth of flywheel shield: 9.400 inches. Clutch must be manually operated by driver's foot: Electronics, pneumatics, hydraulics, or any other device may in no way affect the clutch system. Throwout bearing must release all fingers, levers, stages, etc. simultaneously. Staged or variable release clutches of any description prohibited. See General Regulations 2:3, 2:5, 2:6, 2:8.

The motor plate must be attached to the chassis using at least two welded mounting points with minimum 3/8-inch Grade 8 bolts and full nuts. At least two additional welded mounting points (using the motor plate, front block plates, etc.) are required to secure the engine to the chassis also with minimum 3/8-inch Grade 8 bolts and full nuts.

DRIVELINE

Driveshaft meeting SFI Spec 43.1 mandatory. Each end of driveshaft must have round 360-degree driveshaft loops within 6 inches of the U-joints. A full 360-degree driveshaft tube mandatory over the yoke, extending from the transmission tail shaft rearward, a minimum length of 12 inches. Minimum thickness of the driveshaft tube housing is .050-inch chromoly or titanium. Two-piece design accepted with minimum 6 3/8-inch Grade 8 bolts. See General Regulations 2:4.

REAR END

All rear ends must be NHRA-accepted. A current list of NHRA-accepted rear ends is available on NHRARacer.com. Aftermarket axles with minimum 5/8-inch-diameter studs and axle-retention device mandatory. Full-floating or live axle units mandatory on all entries. Maximum (numeric) rear-end gear ratio 4.57-to-1 for supercharged and turbocharged entries. See General Regulations 2:11.

TRANSMISSION

Aftermarket planetary, clutchless, or automatic transmission permitted. All transmissions must be equipped with an SFI Spec 4.1 transmission shield.

Supercharged and turbocharged entries limited to maximum of three forward speeds and reverse; nitrous-assisted entries limited to maximum of five forward speeds and reverse.

Aftermarket converter drive units permitted. When an automatic transmission or converter drive is utilized, an SFI Spec 6.1 or 6.3 flywheel shield and an SFI Spec 29.1 or 29.2 flexplate are mandatory. All entries utilizing a converter must be equipped with a neutral safety switch and a reverse lockout. Bolt together torque converters must be through bolt design using a minimum Grade 8 bolt with locking nut. Transmission brake permitted on all converter-equipped entries, electric transbrake release system only. All entries using a torque converter must utilize a belly pan, see BODY: 7, BELLY PAN.

Lockup converters are prohibited on supercharged and turbocharged combinations. Lockup converters are permitted on nitrous-assisted combinations. Overdrive units are prohibited on all combinations. A 1-to-1 relationship is mandatory in high gear for all transmission types. Automated, electric, or pneumatic shifting devices permitted on all transmission types; must be controlled by preset engine rpm and/or time functions only. Iterative transmission staging device permitted on converter cars. Manipulation of transmission or converter pressure or volume other than at the starting line is prohibited. Pressure manipulation control must be disarmed upon the release of the transbrake or any other device used when launching the vehicle. See General Regulations 2:12, 2:13, 2:14.

BRAKES & SUSPENSION: 3

BRAKES

Automated brakes prohibited; application and release of brakes must be a function of the driver. Four-wheel hydraulic disc brakes mandatory. Carbon-fiber brake rotors used in conjunction with carbon-fiber specific brake pads mandatory on front and rear. Steel and/or braided steel brake lines mandatory. Brake lines must be out of flywheel and driveline area. Line-loc permitted. Two line-loc solenoids and one button permissible. Using the line-loc for traction control is prohibited. Any other electrical, pneumatic, hydraulic, etc. switch prohibited in brake system. Dual master cylinder mandatory; must be mounted above the lower framerails. See General Regulations 3:1.

STEERING

Commercially available quick-disconnect steering wheel adapter meeting SFI Spec 42.1 mandatory. Minimum steering-wheel diameter 11 inches. See General Regulations 3:3.

SUSPENSION

Full automobile production systems mandatory. Minimum one hydraulic shock absorber per wheel. Fabricated units permitted. Rigid-mounted suspensions or straight front axles prohibited. Lockup shocks prohibited. Active suspension of any kind prohibited. Any ability to make on-track setting/rate changes based on "real time" data or input from any source, including the shock/strut itself (i.e., magnetically charged fluid), is prohibited. Electrically or pneumatically controlled, hydraulic shocks and/or struts are permitted, provided all adjustment settings/changes are preset before the run.

Only 1 three-wire shielded cable connection is permitted from the top of the shock/strut to the shock/strut controller. Electrical connections of any other kind to or from the shock/strut prohibited.

Shock/strut travel sensors permitted, but may ONLY be connected to the vehicle data recorder. Shock/strut control boxes that have connections for travel sensors must have the pin removed from the connector.

Shock absorber control boxes must be NHRA-accepted. A current list of NHRA-accepted control boxes is available on NHRARacer.com. Any connection to the control box to change settings prohibited once car reaches the ready line. All wiring must be visible and easily traceable for the technical inspectors. See General Regulations 3:4.

WHEELIE BARS

Permitted. Maximum 104 inches as measured from centerline of rear-end housing to center of wheelie-bar wheel. Wheels must be nonmetallic. See General Regulations 3:6.

FRAME: 4

BALLAST

Permitted. Any ballast mounted on, or in front of, forward crossmember is limited to 30 pounds maximum, including bracket. Maximum length of bracket 12 inches, measured from the front of the crossmember. Maximum distance from front motor plate to front of bracket is 36 inches. Bracket may be constructed of either minimum 1 1/4-inch x .058-inch wall round chromoly tubing with minimum four (4) 3/8-inch-diameter SAE Grade 8 bolts for attachment, or of minimum 1/4-inch 6061 T6 aluminum plate with minimum four (4) 1/2-inch SAE Grade 8 bolts for attachment. All other weight bars, pucks, etc. must use minimum 1/2-inch-diameter SAE Grade 8 bolts for attachment. See General Regulations 4:2.

GROUND CLEARANCE

A minimum 3 inches of ground clearance is mandatory from the front of the vehicle to 12 inches behind the centerline of the front axle. A minimum of 2 inches of ground clearance is mandatory for remainder of vehicle, except oil pan and exhaust headers. See General Regulations 4:5.

PARACHUTE

Dual parachutes mandatory. Parachute packs and unpacked shroud lines must be protected with fire-resistant material from the mounting point to the pack. Separate shroud-line mounting points required with 1/2-inch sleeved Grade 8 bolts. See General Regulations 4:8.

ROLL CAGE

Chassis must meet SFI Spec 25.1. Chassis must be recertified yearly by NHRA and have serialized sticker affixed to roll cage before participation. See General Regulations 4:4, 4:11, 10:6.

A panel of .032-inch aluminum, .024-inch steel, or carbon fiber must be installed on the inside portion of the roll cage anywhere the driver's legs can come into contact with the cage. Panels must be installed in the front and lower portion of the driver's-side X brace. Panels must attach to the interior side of the tubing, or no farther than the middle of the tubing, with "impact-type" padding attached to the panels. Padding must extend to be flush with X brace. Minimum padding thickness is 1/4-inch.

An additional panel(s) of .032-inch aluminum, .024-inch steel, or carbon fiber must be installed in the roll cage roof area. The panel(s) must, at a minimum, extend from the driver's side roof bar to the centerline of the vehicle. The panel(s) in the Funny Car cage area must be removable for proper chassis certification inspection.

ROLL-CAGE PADDING

Roll-cage padding meeting SFI Spec 45.1 mandatory anywhere the driver's helmet may come in contact with roll-cage components. Additional padding mounted on flat stock and fastened to the roll cage on both sides of the driver's helmet, mandatory. Additional padding must be NHRA-accepted, securely mounted using bolts or locking fasteners, and must include a flame-retardant covering. A current list of NHRA-accepted lateral head supports is available on NHRARacer.com. See General Regulations 4:11.

WHEELBASE

Minimum 100 inches, maximum 115 inches. Full-size trucks, maximum 140 inches; S-10, Dakota, Ranger, maximum 125 inches. Maximum wheelbase variation from left to right: 2 inches.

TIRES & WHEELS: 5**TIRES**

Tires may not extend outside body line. All tires must have manufacturer, model, and size information clearly designated. Maximum height of front tires is 25 inches. See General Regulations 5:1.

WHEELS

SFI Spec 15.1 or 15.3 rear wheels measuring 16x16 inches with double bead locks or liners mandatory. Modification and/or lightening prohibited. Wheel discs or covers prohibited. See General Regulations 5:2.

INTERIOR: 6**DRIVER COMPARTMENT**

Driver compartment interior must be aluminum, steel, or carbon fiber. Magnesium prohibited. Sheet metal may not extend into rear window any higher than wheel tubs. Rear wheelwells must be separate for each tire. Maximum height of rear wheel tubs from ground, 40 inches. Trunk must be completely separated from driver compartment with a firewall. See General Regulations 6:1.

SEAT

Driver's seat must be minimum 24 inches high. Seat must be foamed with energy-absorbing material and formed to the driver's body and covered with a minimum one-layer, flame-retardant material. Seat frame must be installed as a permanent part of the chassis. See General Regulations 6:2.

WINDOW NET

Window net meeting SFI Spec 27.1 mandatory. See General Regulations 6:3.

BODY: 7**BELLY PAN**

Permitted on all cars; mandatory on all entries using a torque converter. Pan must extend from framerrail to framerrail and extend from the bellhousing/engine mounting surface to the end of the transmission tail shaft. Nonflammable, oil-absorbent liner is mandatory inside of belly pan.

BODY

Both doors must be functional from inside and outside. One-piece or Funny Car-type bodies prohibited. Front overhang not to exceed 45 inches forward of the front spindle. If front overhang of selected body is less than the maximum of 45 inches, an extension may be added to reach the maximum length.

No holes permitted in rear of body. Two hinged openings with total maximum of 120 square inches permitted. Maximum 1-inch rocker panel extensions and fender flares (lips) permitted. Lip may not extend beyond forward half of wheel opening.

New car plans must be submitted to NHRA for design approval prior to body construction, along with three photos of completed body prior to painting. All models must be accepted prior to competition. If a particular body style is creating conditions that are detrimental to the variety of the eliminator, adjustments may be made at any time, at the discretion of NHRA.

All entries must incorporate a metal deflector (firewall extension) between the fenders and the leading edge of the doors such that fire, liquids, etc. can not come around the edge of the firewall and into the driver's compartment.

COMPETITION NUMBERS AND APPEARANCE

All cars in competition must be painted, lettered/numbered, and professionally decaled. See General Regulations 7:2, 10:2.

FIREWALL

Minimum .024-inch steel or titanium firewall mandatory. Aluminum, magnesium, or composite prohibited. See General Regulations 7:4.

FLOOR

Driver's-side floor pan must be a minimum of .024-inch steel and must be welded in place. Remainder of floor must be .024-inch steel, .032-inch aluminum, or carbon fiber. Magnesium interior panels prohibited. See General Regulations 7:5.

HOOD SCOOP & INJECTOR SCOOP

Hood scoops permitted. May not extend above the roof line. Must be finished and painted to follow body paint scheme. Sensors, transducers, vents, wiring, hoses, etc. prohibited inside hood scoop. Nitrous-assisted entries must utilize either a hood scoop or cowl hood to completely cover carburetors. Throttle bodies only may be exposed on fuel-injected nitrous-assisted entries. On supercharged entries, injector scoop may not extend more than 16 inches forward of the center of the forward engine cylinder, may not extend more than 10 inches behind the center of the rear engine cylinder, and the top of the injector scoop may not be more than 1.50 inches above the roof.

WINDSHIELD, WINDOWS

Full windows mandatory, 1/8-inch polycarbonate material permitted. Windows must be closed; need not be operative. Cutting and/or notching windshield permitted if covered by hood and/or scoop. Minimum 4-inch-diameter opening on side windows of all entries mandatory. See General Regulations 7:8.

WING/SPOILERS

Any style rear wing and/or spoiler permitted. Adjustment during run prohibited.

ELECTRICAL: 8

BATTERIES

Maximum total weight wet, fully charged, including battery box: 100 pounds. If mounted inside driver compartment, battery must be located in a sealed .024-inch steel or titanium, or .032-inch aluminum box. See General Regulations 8:1.

IGNITION

Maximum one magneto or distributor. Maximum one spark plug per cylinder. Magneto systems are limited to a single 44-amp maximum output system. The use of MSD 7531 unit is permitted

on nitrous-assisted entries only. Electronic starting line rpm limiters (two-steps) are permitted on all entries. See General Regulations 8:3.

MASTER CUTOFF

Mandatory. See General Regulations 8:4.

STARTERS

All entries must be self starting with an onboard starter. The use of remote-mounted battery packs permitted for starting purposes only. See General Regulations 8:5.

TAILLIGHTS

One functional taillight mandatory. See General Regulations 8:6.

SUPPORT GROUP: 9

DATA RECORDERS

Data recorders permitted; must be standalone, NHRA-accepted, and used for information gathering only. A current list of NHRA-accepted data recorders is available on NHRARacer.com Digital dash display permitted. Ride height sensors permitted; may only be connected to data recorder. See General Regulations 9:1, 9:2, 9:11.

EVENT DATA RECORDER

Properly installed and operational PRC Systems Event Data Recorder (part number EDR1.0 or EDR2.0) and PRC Systems Wire Assembly (part number WA1.0 or WA2.0) mandatory. The PRC Systems Event Data Recorder and Wire Assembly must be installed per the manufacturer's instructions. Modification of or tampering with the PRC Event Data Recorder and Wire Assembly prohibited.

FIRE EXTINGUISHER SYSTEM

Minimum 20-pound NHRA-accepted fire extinguishing system mandatory. System must be divided so that a minimum of 15 pounds is directed into engine compartment by means of nozzled outlets placed in front of each bank of exhaust headers. Remaining 5 pounds or more should be dispersed in driver compartment by means of an atomizing nozzle placed at driver's feet. Must be installed per manufacturer's specifications. Fire bottle activation cables must be installed inside framerail where cables pass engine/bellhousing area. If fire bottles are mounted in front of the firewall, they must be connected to the nozzle system with flexible steel braided line. All cars are required to have a pneumatic cylinder, pressurized by the fire system that will activate the master kill switch and shut off the engine when fire system is activated. See General Regulations 9:3 for NHRA-accepted fire extinguishing agents.

PRESSURIZED BOTTLES

Maximum one pressurized container per vehicle (excluding nitrous and fresh-air system bottles). See General Regulations 9:8.

SHUTOFF DEVICE

Supercharged and turbocharged cars are required to have properly installed and operational Electrimotion Pro Mod Shutoff Controller Kit (part number SB001) and Electrimotion Shutoff Receiver (part number RF001). Nitrous cars are required to have properly installed and operational Electrimotion Shutoff Receiver (part number RF001PS). The Electrimotion Pro Mod Shutoff Controller Kit and Shutoff Receiver must be properly installed per the manufacturer's instructions. Modification or tampering with the Electrimotion Pro Mod Shutoff Controller Kit and Shutoff Receiver prohibited.

TOW VEHICLE

Permitted. See General Regulations 9:12.

WARM-UPS

See General Regulations 9:5, 9:14.

DRIVER: 10**APPEARANCE**

All cars in competition must be painted, lettered/numbered, and professionally decaled. See General Regulations 7:2.

CREDENTIALS

Valid NHRA competition license mandatory. All competitors at NHRA Mello Yello national events must be a minimum of 18 years of age. See General Regulations 10:4.

DRIVER RESTRAINT SYSTEM

A minimum six-point driver restraint system meeting SFI Spec 16.1 or six-point driver restraint system meeting SFI Spec 16.5 mandatory. Restraint system must be updated at two-year intervals from date of manufacture. See General Regulations 10:5.

HELMET

For all cars, a full-face Snell SA2010, or SA2015 helmet and shield mandatory (goggles prohibited). Eject Helmet Removal System (Part # SDR 890-01-30) mandatory and must be installed per manufacturer instructions. A Stand 21 Lid Lifter head sock meeting SFI 3.3 may be used in lieu of the Eject Helmet Removal System. See General Regulations 10:7.

HEAD AND NECK RESTRAINT DEVICE/SYSTEM

A head and neck restraint device/system meeting SFI Spec 38.1 is mandatory. See General Regulations 10:8.

PROTECTIVE CLOTHING

Driver's suit meeting SFI Spec 3.2A/20, SFI Spec 3.3/20 gloves, and SFI Spec 3.3/20 boots mandatory for entries. An SFI 3.3 head sock or SFI 3.3 skirted helmet is required on all cars. See General Regulations 10:10.

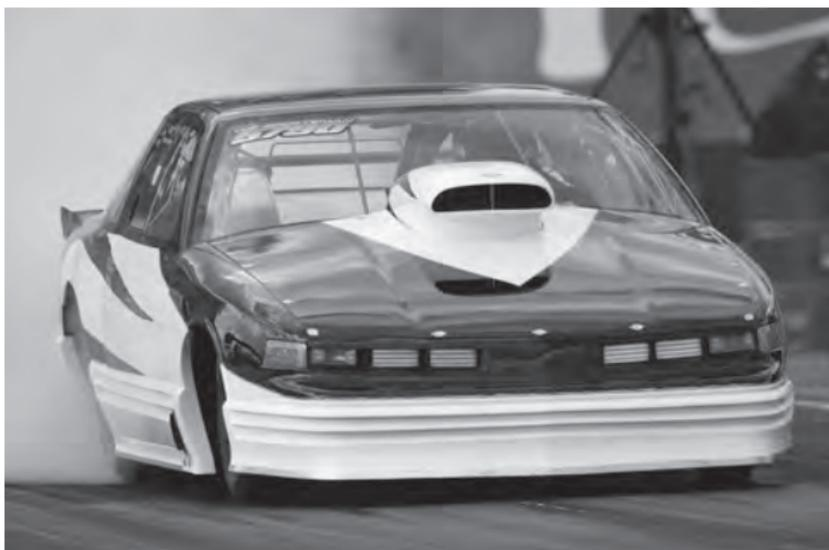

TS & TD

SECTION 7 TOP SPORTSMAN PRESENTED BY RACING RVs AND TOP DRAGSTER PRESENTED BY RACING RVs

SECTION 7A TOP SPORTSMAN

Class is for full-bodied side-steer-type vehicles only. Qualified fields with competition conducted in a dial-in e.t. format. Minimum 6.10-second dial-in; maximum 7.99-second dial-in (eighth-mile, minimum 3.70- to 5.29-second dial-in).

DESIGNATION

TS followed by car number. Number must be at least 4 inches high. Minimum weight at the conclusion of run, including driver:

Small-block combinations

Naturally aspirated: 1,900 pounds

Nitrous assisted: 2,000 pounds

Supercharged or turbocharged: 2,100 pounds

Big-block combinations

Naturally aspirated: 2,200 pounds

Nitrous assisted: 2,450 pounds

Supercharged or turbocharged: 2,600 pounds

Six-cylinder vehicles

Supercharged or turbocharged: 2,100 pounds

Four-cylinder vehicles

Supercharged or turbocharged: 1,900 pounds

REQUIREMENTS & SPECIFICATIONS**ENGINE: 1****ENGINE**

Any internal combustion engine allowed with any modification. Only one engine may be used. No cubic-inch limit. Harmonic balancer meeting SFI Spec 18.1 mandatory.

EXHAUST SYSTEM

Competition exhaust systems permitted. Exhaust gases must be directed out of the car body, rearward, away from driver and fuel tank. If zoomies are utilized must be turned upward minimum 3 degrees.

FUEL

Racing gasoline, gasoline, alcohol, gasohol, ethanol, diesel permitted. Nitromethane and propylene oxide prohibited.

FUEL SYSTEM

No part of the fuel system may be mounted on firewall or in flywheel/flexplate area. If fuel tank/cell is mounted in rear, it must be vented to the outside of the body and equipped with a flash shield to isolate system from driver compartment. All front-mounted fuel systems must be mounted between framereils and enclosed in a round tube frame, minimum 1 1/4 inches O.D. x .065 chromoly or .118 mild steel tubing.

INDUCTION

Any number and type of carburetors or throttle bodies may be used. Electronic fuel injection permitted. Two return springs mandatory. Throttle stops prohibited. See General Regulations 9:1, 9:11.

LIQUID OVERFLOW

Catch can mandatory for coolant overflow; one-pint (16-ounce) minimum capacity. See General Regulations 1:7.

OIL LINES

All flexible-pressure oil lines, excluding return lines and any line 30psi or lower in pressure, must pass a minimum 300psi test for 30 seconds with no indications of separation, weeping, leaking, etc. Competitors may test and tag their own lines. Label must indicate date, psi, and tester ID; label must be impervious to fuel and brake-clean. Lines must be tested and tagged within two years. All lines on supercharged alcohol cars must be routed in such a way that they are not directly in line with cylinder head gaskets at the front, rear, or side of the cylinder heads.

OIL-RETENTION DEVICE

All cars must utilize an NHRA-accepted lower engine oil-retention device; may use a belly pan in lieu of a device attached to the engine. Pan must run from in front of the front motor plate to in front of the rear motor plate and from framereil to framereil. On vehicles without a front motor plate, pan must run from in front of harmonic balancer to in front of rear motor plate and from framereil to framereil, All belly pans must incorporate a minimum 2-inch-high lip on all sides. A nonflammable, oil-absorbent liner mandatory inside of retention device. See General Regulations 1:8.

SUPERCHARGER

All supercharged entries may utilize a 14-71 (or smaller) standard or hi-helix supercharger. OEM-type screw supercharger permitted, all others prohibited. OEM-type screw superchargers do not require a supercharger restraint. "OEM-type" in this case means that it must have originally come with the production engine being used. All cars using 12-71 or 14-71 superchargers must have an SFI 14.2 or 14.3 Supercharger Restraint with

approved bag from same manufacturer. All other superchargers require an SFI 14.1, 14.2 or 14.3 Supercharger Restraint. Belt guards shielding both fuel and oil lines are mandatory. The blower restraint straps and fuel lines must be installed such that when the restraint straps are fully extended no load is placed on any of the fuel lines. Aluminum studs (supercharger-to-manifold) mandatory. See General Regulations 1:10, 1:11.

TURBOCHARGER

The use of single or dual turbochargers is permitted. This combination will compete at the supercharged weight minimums.

THROTTLE STOP

The use of throttle stops, stutter boxes, etc. to control downtrack engine rpm is prohibited. Throttle stops are defined as being mechanical, electronic, or pneumatic. Throttle stop may be present on vehicle but must be disconnected from all controls.

STARTER

All entries must be self-starting with an onboard starter and battery.

VALVE COVERS

Cast or fabricated metal valve covers, using all attachment bolt holes, mandatory on supercharged or turbocharged cars.

VENT TUBE/BREATHERS

Mandatory for all supercharged engines. Two 1-inch-diameter connections. All breathers must be positive locking.

DRIVETRAIN: 2

CLUTCH, FLYWHEEL, FLYWHEEL SHIELD

Flywheel and clutch meeting SFI Spec 1.1, 1.2, 1.3, 1.4, or 1.5 mandatory. Flywheel shield meeting SFI 6.1, 6.2, or 6.3 mandatory on clutch-equipped cars. Engine combination determines the appropriate specifications. See the appropriate SFI Specification or NHRA General Regulations for the motor plate and bolting requirements.

DRIVELINE

Each end of driveshaft must have round 360-degree driveshaft loops within 6 inches of U-joints. Driveshaft must be covered by 360-degree tube, covering the front U-joint and extending rearward a minimum 12 inches. Minimum thickness of tube is .050-inch chromoly or titanium. Driveshaft tube must utilize a minimum of four attachment points to the chassis, either bolted with minimum 5/16 SAE bolts or welded or 1/4-inch push/pull pins. See General Regulations 2:4.

FLEXPLATE

Automatic transmission flexplate meeting SFI Spec 29.1 mandatory.

FLEXPLATE SHIELD

Flexplate shield meeting SFI Spec 30.1 mandatory. An SFI 6.1 bellhousing is permitted on torque converter assisted planetary transmissions.

REAR END

Aftermarket axles and axle-retention devices mandatory. Welded spider gears prohibited. Wheel studs must be 5/8-inch minimum. Aftermarket full-floating or live axle assembly permitted. Independent rear suspension prohibited.

TRANSMISSION

Any transmission may be used; however, vehicle must employ positive system to disengage from final drive. All automatic transmissions must have a neutral safety start switch and

reverse lockout device. All pressurized units must utilize flexible hoses pressure tested to 300psi and be clearly labeled as passing the testing process or steel lines and AN fittings to connect with accessory coolers. A minimum 1/8-inch pipe connection using high-pressure line vent to overflow tank (minimum 1-pint capacity) is mandatory.

TRANSMISSION SHIELD

A one-piece transmission shield meeting SFI Spec 4.1 is mandatory on all automatic and planetary transmissions.

BRAKES & SUSPENSION: 3

BRAKES

Four-wheel brakes mandatory with dual master cylinder mounted above framereils on all entries. Steel brake lines mandatory.

STEERING

If removable steering wheel is used, commercially available quick-disconnect steering wheel adapter meeting SFI Spec 42.1 is mandatory.

WHEELIE BARS

Permitted. Wheels must be nonmetallic. See General Regulations 3:6.

FRAME: 4

BALLAST

Permitted, 250 pounds maximum, 100 pounds maximum removable.

CHASSIS

All cars must use a full frame that meets SFI Spec. 25.1, 25.2, or 25.3 that run 7.499 and quicker. Cars running 7.50 and slower must meet applicable SFI Specification (25.1, 25.2, 25.3, 25.4, or 25.5) for body/chassis design. Must have current NHRA serialized sticker affixed to the cage before participation.

ROLL-CAGE PADDING

Roll-cage padding meeting SFI Spec 45.1 mandatory anywhere driver's helmet may come in contact with roll-cage components. See General Regulations 4:11.

GROUND CLEARANCE

Minimum 3 inches required from the front of the car to 12 inches behind axle centerline, 2 inches for remainder of car except oil pan and exhaust headers.

PARACHUTE

Required. Cars running in excess of 200 mph must use dual parachutes. See General Regulations 4:8.

WHEELBASE

Minimum 90 inches. One-inch variation from left to right.

TIRES & WHEELS: 5

TIRES

Must be automotive type, designed for racing.

WHEELS

Each car in competition must be equipped with automotive-type wheels, designed for racing. SFI Spec 15.1 rear wheels with beadlocks or liners mandatory on any vehicle that runs 6.50 and quicker or 210 mph and faster.

INTERIOR: 6

UPHOLSTERY

Optional. See General Regulations 6:2.

WINDOW NET

Window net meeting SFI Spec 27.1 mandatory. See General Regulations 6:3.

BODY: 7**BODY**

Must be full-bodied vehicle (trucks, vans, wagons permitted) with two functional doors. Front overhang limited to 45 inches from center of front spindle unless stock OEM is longer.

FIREWALL

Required. Each car in competition must be equipped with minimum .024-inch steel or .032-inch aluminum firewall.

FLOOR

Minimum .024-inch steel welded in on driver's side from firewall to rear crossmember. Remainder .032 aluminum, .024-inch steel, or NHRA-accepted carbon fiber.

HOOD SCOOP

Maximum height of 15 inches. Measured from flat portion of hood to top of opening.

WINDSHIELD, WINDOWS

Required, no window tint beyond factory specification permitted. The side windows on all entries that utilize nitrous oxide or are supercharged must have a minimum 4-inch-diameter opening adjacent to the driver. See General Regulations 7:8.

SPOILERS/WINGS

Non OEM airfoils or wings permitted; must be permanently attached to frame or roll cage; nonadjustable during run. a positive locking device to prevent movement is mandatory.

ELECTRICAL: 8**BATTERIES**

All batteries must be securely mounted. See General Regulations 8:1.

DELAY BOX/DEVICE

Permitted. Pneumatic starting-line enhancers are permitted for all applications. See General Regulations 8:2.

IGNITION

Aftermarket electronic ignition boxes must be used unaltered from factory specifications. Timed ignition-interruption devices (stutter boxes) prohibited. Starting-line and/or "high-side" rev limiters permitted. Two-steps, rev limiters, or any other rpm-limiting devices, legal unto themselves but altered or installed so as to function as a downtrack rpm controller, prohibited. All wiring associated with the ignition system must be fully visible, labeled, and traceable. See General Regulations 8:3.

MASTER CUTOFF

An external master electrical cutoff switch required. If the switch is the "push/pull" type "push" must be the action for shutting off the electrical system, "pull" to turn it on. The off position must be clearly indicated on all cars. See General Regulations 8:4.

TAILLIGHTS

One functional taillight mandatory. Flashing, blinking, or strobe lights prohibited. See General Regulations 8:6.

SUPPORT GROUP: 9**DATA RECORDER**

Permitted. Data recorders may be used to record functions of a vehicle so long as they do not activate any function on the

vehicle. Data recorder may not be activated by the throttle, clutch, brake, etc. Must be activated by a separate switch. Data may be reviewed (printout, replay, etc.) only after the run. See General Regulations 9:1, 9:2.

FIRE EXTINGUISHER SYSTEM

Mandatory on all cars. Minimum 5-pound NHRA-accepted system. Supercharged methanol-burning cars, minimum 20-pound NHRA-accepted system. System must be divided with a minimum one nozzle directed into the driver compartment and minimum one nozzle directed into the engine compartment. See General Regulations 9:3 for accepted agents.

TOW VEHICLES

Golf cart or three- or four-wheeled, Quadrunner/ATV-type tow vehicle permitted. Full-size tow vehicle prohibited. See General Regulations 9:10.

WARM-UPS

See General Regulations 9:5, 9:14.

DRIVER: 10**CREDENTIALS**

NHRA competition license and NHRA Top Sportsman number with appropriate license code 3B and NHRA membership required.

DRIVER RESTRAINT SYSTEM

Driver restraint system meeting SFI Spec. 16.1 or 16.5 mandatory. Restraint system must be updated at two-year intervals from date of manufacture.

HELMET

Full-face helmet meeting Snell M2010, M2015, SA2010, or SA2015 mandatory; shield mandatory (goggles prohibited). See General Regulations 10:7.

NECK COLLAR/HEAD AND NECK RESTRAINT DEVICE/SYSTEM

A head and neck restraint device/system meeting SFI 38.1 mandatory and must display a valid SFI label. At all times that the driver is in the race vehicle, from the ready line until the vehicle is on the return road, driver must properly utilize an SFI 38.1 head and neck restraint device/system, including connecting the helmet as required for full functionality of the device. The head and neck restraint device/system, when connected, must conform to the manufacturer's mounting instructions, and it must be configured, maintained, and used in accordance with the manufacturer's instructions. Modification of the device is prohibited. An SFI 38.1 head and neck restraint device can be used with, or without, a neck collar; when a neck collar is not used, an SFI 3.3 head sock or SFI Spec 3.3 skirted helmet is required.

PROTECTIVE CLOTHING

Jacket and pants or suit meeting SFI Spec 3.2A/15, gloves meeting SFI Spec 3.3/5, and boots or shoes meeting SFI Spec 3.3/5 mandatory. See General Regulations 10:10.

SECTION 7B TOP DRAGSTER

Requirements and specifications for Top Dragster are the same as those for Top Sportsman - Section 6A - with the following exceptions:

Class is for dragster and open-bodied altered-type vehicles only. Altered must have open front wheels. Full-fender and/or running-board-equipped street roadsters or Funny Car bodies prohibited. Qualified fields with competition conducted in a dial-in E.T. format. Minimum 6.10-second dial-in; maximum 7.70-second dial-in (eighth-mile, 3.70 to 4.99 seconds).

DESIGNATION

TD followed by car number. Numbers must be at least 4 inches high. Minimum weight at the conclusion of run, including driver:

Small-block dragster or altered

Naturally aspirated: 1,450 pounds

Nitrous assisted: 1,550 pounds

Supercharged or turbocharged: 1,650 pounds

Big-block dragster or altered

Naturally aspirated: 1,500 pounds

Nitrous assisted: 1,700 pounds

Supercharged or turbocharged: 1,800 pounds

Four- or six-cylinder dragsters or altered

Naturally aspirated: 1,400 pounds

Nitrous assisted: 1,500 pounds

Supercharged or turbocharged: 1,600 pounds

REQUIREMENTS & SPECIFICATIONS

ENGINE: 1

FUEL SYSTEM

Fuel lines must be isolated from driver compartment with a subfloor or with steel-braided lines where the engine is located in the rear and the fuel tank is in front of the driver. No part of the fuel system may be mounted on firewall or in flywheel/flex plate area. All entries must have sufficient tank capacity to make full runs; adding of fuel after the engine has started is prohibited. All fuel tanks must be equipped with a positive locking screw-on cap and vented to outside of body.

SUPERCHARGER

Roots-type, high-helix roots-type, centrifugal or screw-type supercharger permitted. Screw-type supercharger must meet SFI Spec 34.1 and be reinspected by the manufacturer every three years. Manifold burst panel meeting SFI Spec 23.1 (in addition to panel in supercharger) plus restraint system meeting SFI Spec 14.21 mandatory on all screw-type superchargers. Front-engine cars must use an SFI Spec 14.2 or 14.3 supercharger restraint. Rear-engine cars must have SFI Spec 14.1, 14.2, or 14.3 supercharger restraint. Supercharger restraint straps must be covered with a fire-resistant material. The blower restraint straps and fuel lines must be installed such that when the restraint straps are fully extended, no load is placed on any of the fuel lines. See General Regulations 1:10.

All supercharged dragsters must utilize a torque converter assisted transmission.

DRIVETRAIN: 2**TRANSMISSION**

Clutchless transmissions are limited to five forward gears; aftermarket planetary limited to three forward gears.

BRAKES & SUSPENSION: 3**BRAKES**

Minimum of two rear-wheel hydraulic brakes required. Hand brake, if used, must be located inside the car's body or driver's compartment. Steel brake lines mandatory. All brake lines passing the engine on any rear-engine car must be shielded; recommended in all cars.

STEERING

A device must be used to prevent steering shaft from injuring driver in case of frontal impact. Shaft must attach to steering box via a positive locking device; i.e., no rolled/pressed pins.

PINION SUPPORT

Mandatory that all entries have a rear axle and/or pinion housing anti-rotation device of a rigid design attached directly from the frame or suitable crossmember to either the rear axle housing or pinion housing in a manner to prevent rotation in either direction for unsuspended rear ends.

SUSPENSION

Any automotive suspension permitted. Rigid-mounted rear axles permitted. Rigid-mount front axles permitted if wheelbase is 120 inches or more. A device must be utilized that will protect the oil pan from coming in contact with the racing surface in case of excessive frame flex and/or tire or wheel failure. Any front suspension using a beam or tubular axle must have the radius rods attached to the frame. Radius rods not required on front axles that are rigidly mounted 18 inches or less from the kingpin.

FRAME: 4**CHASSIS**

Must have NHRA serialized sticker affixed to frame for applicable E.T. before participation. Rear-engine dragster must conform to SFI Spec 2.1, 2.3, 2.5, or 2.7. Front-engine dragster must conform to SFI Spec 2.2, 2.4, or 2.6. Altered must conform to SFI Spec 10.1E, 10.2, or 10.3. All side-steer altered must meet the requirements of SFI 10.4 for applicable E.T. prior to competition.

DEFLECTOR PLATE

Mandatory on rear-engine cars. Must be installed between roll cage and engine on all rear-engine cars to protect driver. Minimum material thickness: .125-inch aluminum or .060-inch steel.

WHEELBASE

Rear-engine dragster minimum 150 inches, maximum 300 inches. Front-engine dragster minimum 150 inches, maximum 300 inches. Altered minimum 120 inches and maximum 150 inches. Maximum wheelbase variation from left to right: 2 inches.

WHEELS & TIRES: 5**TIRES**

Minimum diameter of 13 inches on front tires.

WHEELS

Automotive-type wire wheels permitted on dragster front axle only, provided total car weight does not exceed 1,800 pounds,

excluding driver. Front-wheel fairings prohibited. SFI Spec 15.1 rear wheels with beadlocks or liners mandatory on any vehicle that runs 6.50 and quicker or 210 mph and faster.

INTERIOR: 6

UPHOLSTERY

Optional. For all front-engine open-bodied vehicles supercharged or turbocharged (gasoline- or methanol-burning), a flame-retardant-material-covered seat is mandatory. See General Regulations 6:2.

BODY: 7

AIRFOIL

A positive-locking device must be used to prevent accidental movements. Side-mounted canard-type units are permitted. No part of canards/wings may be within 6 inches of rear tire. A rear wing is mandatory on all cars that exceed 200 mph; minimum area 360 square inches, maximum 750 square inches, minimum height 55 inches (measured vertically from trailing edge to ground). Spill plates must be flat/straight and parallel and measure a minimum of 50 square inches each. Leading edge of wing may be no more than 10 inches forward of the centerline of the rear axle. Wing may not be configured or installed so as to generate negative downforce or lift. Any adjustment or movement during run prohibited.

BODY

Body and cowl may be constructed of metal, fiberglass, or carbon fiber and must extend forward to firewall. Altered entries must use a reproduction pre-1949 roadster or pre-1949 open (front) wheeled NHRA-accepted body (i.e., 1936-48 Fiat, Volkswagen etc. with roof exit). Driver compartment, frame structure, roll bars, and body must be designed to prevent driver's body or limbs from contact with wheels, tires, exhaust system, or track surface. If driver's body is in contact with belly pan, a crossmember and subfloor are mandatory. Front overhang maximum 30 inches from forwardmost spindle center.

SUPPORT GROUP: 9

FIRE EXTINGUISHER SYSTEM

Minimum 5-pound NHRA-accepted system mandatory on all rear-engine cars WITH an enclosed cockpit. Minimum 20-pound NHRA-accepted system mandatory on all front-engine open-bodied vehicles with supercharger or turbocharger(s). System must be divided with a minimum one nozzle directed into the driver compartment and minimum one nozzle directed into the engine compartment. See General Regulations 9:3 for NHRA-accepted fire extinguishing agents.

DRIVER: 10

CREDENTIALS

NHRA Competition license and NHRA Top Dragster number with appropriate 3A or 3B license code and NHRA membership required.

DRIVER

Any location permitted in compliance with General Regulations. Any car with no crossmember above driver's leg must have a strap or device to prevent legs from projecting outside chassis.

DRIVER RESTRAINT SYSTEM

Driver restraint system meeting SFI Spec. 16.1 or 16.5 mandatory. All belts used in open-bodied front-engine supercharged methanol-burning vehicles must be covered with

a fire-resistant covering. Restraint system must be updated at two-year intervals from date of manufacture.

HELMET

For all open-bodied naturally aspirated gasoline- or methanol-burning cars, a full-face Snell M2010, M2015, SA2010, or SA2015 mandatory; shield mandatory (goggles prohibited). See General Regulations 10:7.

For all open-bodied front-engine or rear-engine supercharged, turbocharged, or nitrous cars, a full-face Snell SA2010, or SA2015 helmet and shield mandatory (goggles prohibited).

NECK COLLAR/HEAD AND NECK RESTRAINT DEVICE/SYSTEM

A head and neck restraint device/system meeting SFI 38.1 mandatory and must display a valid SFI label. At all times that the driver is in the race vehicle, from the ready line until the vehicle is on the return road, driver must properly utilize an SFI 38.1 head and neck restraint device/system, including connecting the helmet as required for full functionality of the device. The head and neck restraint device/system, when connected, must conform to the manufacturer's mounting instructions, and it must be configured, maintained, and used in accordance with the manufacturer's instructions. Modification of the device is prohibited. An SFI 38.1 head and neck restraint device can be used with, or without, a neck collar; when a neck collar is not used, an SFI 3.3 head sock or SFI Spec 3.3 skirted helmet is required.

PROTECTIVE CLOTHING

Jacket and pants or suit meeting SFI Spec 3.2A/15, gloves meeting SFI Spec 3.3/5, and boots or shoes meeting SFI Spec 3.3/5 mandatory, except front-engine open-bodied vehicles with supercharger or turbocharger(s): Jacket and pants or suit meeting SFI Spec 3.2A/20, gloves meeting SFI Spec 3.3/15, and boots or shoes meeting SFI Spec 3.3/15 mandatory. See General Regulations 10:10.



S/ST

SECTION 8 SUPER STREET

DESIGNATION

S/ST, preceded by car number.

Super Street cars run on a 10.90 standard (6.90 for eighth-mile tracks) using a heads-up start and .5-second Pro Tree. Reserved for full-bodied cars with full fenders, hood, grille, top, windshield, and functional doors. Sports cars, street roadsters, vans, and panel trucks permitted. Open-wheel altereds, dragsters, Funny Cars, or motorcycles prohibited. Minimum weight, including driver: 8-cylinder cars, 2,800 pounds; 6-cylinder cars, 2,000 pounds; 4-cylinder and rotary cars, 1,200 pounds.

Timed vehicle-control devices (counters, time displays, etc.), except as outlined under Class Requirements, are prohibited. Display or transmission of track location, time/distance data, etc. prohibited.

Any vehicle running faster than 135 mph must meet minimum requirements for 9.99-second vehicles.

Any competitor who causes an oildown while participating at an NHRA Mello Yello event will be subject to fines and penalties as outlined in Section 2 - Oildown Penalties.

REQUIREMENTS & SPECIFICATIONS

ENGINE: 1

ENGINE

Any automotive engine permitted. Harmonic balancer meeting SFI Spec 18.1 mandatory. Engine location optional. See General Regulations 1:2.

EXHAUST SYSTEM

When competing at national and divisional events, vehicle may not exceed 95 decibels as measured on the "A" scale from a distance of 50 feet, at a right angle to the vehicle, with the vehicle at a no-load rpm of 3,500. Sound-suppression device not mandatory if vehicle passes testing. See General Regulations 1:3.

FUEL

Racing gasoline, gasoline, alcohol, diesel, gasohol, ethanol, CNG, or propane permitted. Nitrous oxide prohibited, except on diesel-turbocharged engines. See General Regulations 1:6.

FUEL SYSTEM

Aftermarket fuel tank or cell permitted. Must be located outside driver compartment and inside body lines. If tank or fuel filler is inside trunk, a bulkhead of minimum .032-inch aluminum or .024-inch steel must be used between trunk and driver compartment, and tank must be vented to outside of car. See General Regulations 1:5.

INDUCTION

Any number and type of carburetors or throttle bodies may be used. Electronic fuel injection permitted. See General Regulations 9:1, 9:11.

LIQUID OVERFLOW

Mandatory. See General Regulations 1:7.

OIL-RETENTION DEVICE

All vehicles must utilize an NHRA-accepted lower engine oil-retention device; may use a belly pan in lieu of a device attached to the engine. If belly pan is used, must extend from framerail to framerail and extend forward of the harmonic balancer and rearward to rear-engine plate and must incorporate a minimum 2-inch-high lip on all sides. A nonflammable, oil-absorbent liner mandatory inside of retention device. See General Regulations 1:8.

SUPERCHARGER, TURBOCHARGER

Permitted only when racing gasoline, gasoline, diesel, or alcohol is used as fuel. Restricted to standard Roots-type, centrifugal, or OEM-type screw supercharger. SFI Spec 14.1 restraints mandatory with Roots-type supercharger when alcohol is used as a fuel. See General Regulations 1:10.

THROTTLE

Throttle control must be manually operated by driver's foot or approved hand control. Electronics, pneumatics, hydraulics, lasers, or any other devices may in no way affect initial throttle operation. Timed throttle stops, which are preset before the run, permitted. Timer may display only throttle timer settings; analog or digital display permitted. See General Regulations 1:12, 8:2, 9:1, 9:2.

DRIVETRAIN: 2**CLUTCH, FLYWHEEL, FLYWHEEL SHIELD**

Flywheel and clutch meeting SFI Spec 1.1, 1.2, 1.3, or 1.4 (two-disc maximum) mandatory. Flywheel shield meeting SFI Spec 6.2 or 6.3 mandatory on all supercharged cars and on all cars using SFI Spec 1.3 or 1.4 clutches. Flywheel shield meeting minimum SFI Spec 6.1 mandatory on all other cars. Cars with rotary engines must be equipped with a flywheel shield made of 1/4-inch-minimum-thickness steel plate surrounding the bellhousing 360 degrees. See General Regulations 2:3, 2:5, 2:6, 2:10.

DRIVELINE

Driveline loop mandatory. See General Regulations 2:4.

REAR END

Aftermarket axles and axle-retention device mandatory. Cars that weigh more than 2,000 pounds with independent rear suspension without upper and lower (both) control arms must replace swing axle differential with conventional differential housing assembly. (Example: 1963-1982 Corvette.) Cars with independent rear suspension using upper and lower (both) control arms may retain swing axle assembly regardless of weight. Must have 360-degree, minimum 1-inch-wide by 1/4-inch-thick axle retention loop on each axle. Quick-change and/or locked differential permitted. See General Regulations 2:2, 2:11.

TRANSMISSION, AUTOMATIC

Spring-loaded, positive reverse lock-out device and functional neutral safety switch mandatory. Transbrake permitted. Transmission that can utilize a high-gear transbrake must be supported by the use of two momentary buttons (one to arm the system, second as the main transbrake). Automatic transmission may be shifted with a preset timed or a preset rpm-activated (but not both) electrical, mechanical, pneumatic, or hydraulic device, or by standard OEM operation only. Rpm-based automatic shifters may not have a time delay incorporated into the device. Rpm-based automatic shifters may not be connected (directly or indirectly) to the delay box/device. Time-based automatic shifters may not be connected (directly or indirectly) to the ignition system. NHRA-accepted aftermarket automatic transmission permitted. See General Regulations 2:14.

TRANSMISSION SHIELD, AUTOMATIC

Transmission shield meeting SFI Spec 4.1 mandatory. See General Regulations 2:14.

BRAKES & SUSPENSION: 3**BRAKES**

Four-wheel hydraulic brakes mandatory. See General Regulations 3:1.

STEERING

Conventional steering system only. Minimum steering-wheel diameter 11 inches. Butterfly steering wheels prohibited. See General Regulations 3:3.

SUSPENSION

Must have automotive-type front suspension commonly used by an automobile manufacturer. Must have one operating hydraulic shock absorber for each sprung wheel. See General Regulations 3:4.

TRACTION BARS

Permitted. See General Regulations 3:5.

WHEELIE BARS

Permitted. Wheels must be nonmetallic. See General Regulations 3:6.

FRAME: 4**BALLAST**

Permitted. See General Regulations 4:2.

BUMPERS

Optional.

FRAME

See General Regulations 4:1, 4:4, 4:11.

GROUND CLEARANCE

Minimum 3 inches from front of car to 12 inches behind

centerline of front axle, 2 inches for remainder of car, except oil pan and exhaust headers. See General Regulations 4:5.

PARACHUTE

Mandatory on any car that runs 150 mph or faster. See General Regulations 4:8.

ROLL CAGE

Mandatory in full-bodied car if vehicle has altered firewall, floor, and/or body (from firewall rearward, wheel tubs and 6 square feet of removable driveline tunnel permitted), or if vehicle runs 135 mph or faster. If vehicle is equipped with unaltered firewall, floor, and body (from firewall rearward, tubs permitted), roll bar permitted in lieu of roll cage. Complete roll cage per General Regulations mandatory in all convertibles. See General Regulations 4:4, 4:11, 10:6.

WHEELBASE

Minimum wheelbase 90 inches. Maximum wheelbase 125 inches unless otherwise produced by automobile manufacturer. Maximum wheelbase variation from left to right: 1 inch.

TIRES & WHEELS: 5

TIRES

Racing slicks permitted. See General Regulations 5:1.

WHEELS

Wire or motorcycle wheels prohibited. Minimum wheel size 13 inches (unless originally equipped with smaller wheels and vehicle is equipped with original engine). See General Regulations 5:2.

INTERIOR: 6

SEATS

Properly braced, framed, and supported seats constructed of aluminum, fiberglass, double-layer poly or carbon fiber (automotive accessory seats) permitted. One seat mandatory. See General Regulations 6:2.

SHEET METAL

Driver-compartment interior must be aluminum, NHRA-accepted carbon fiber, or steel. Magnesium prohibited. See General Regulations 6:1.

TONNEAU COVER

Covers over driver compartment and/or pickup bed permitted if driver entry or exit is not restricted.

UPHOLSTERY

Optional. See General Regulations 6:2.

WINDOW NET

A ribbon-type or SFI 27.1 mesh-type window net is mandatory for any full-bodied car if vehicle runs 135 mph or faster. See General Regulations 6:3.

BODY: 7

BODY

Must be full-bodied car. Coupes, sedans, street roadsters, vans, pickups, sports cars, and panel trucks permitted. Fiberglass bodies permitted. Door hinges on any lift-off door must have safety pins or locks. Cars with top and windshield must have two driver exits. Convertibles and cars that came with removable tops may run without top. Tops may be chopped. Cars without tops do not require working doors. Bodies may be channeled or sectioned. Street roadsters, sports cars, and convertibles may remove top and windshield. Bodies may be set

back. Rear-wheel opening may not extend into door opening. On full-bodied cars, hood scoop may not extend more than 11 inches above height of original hood surface.

FENDERS

Mandatory. Lightweight replacement fenders permitted. Front fenders may be lengthened to fit extended wheelbase. Rear fenders may be cut for tire clearance. Altered fenders must have edges re-rolled or beaded. See General Regulations 7:3.

FIREWALL

Mandatory. See General Regulations 6:1, 7:4.

FLOOR

Mandatory. See General Regulations 6:1, 7:5.

HOOD

Required on full-bodied vehicles. Street roadster may omit side panels.

SPOILERS/WINGS

Rear spoiler permitted. Non-OEM wings prohibited on all body styles. Roof-mounted spoilers, other than original for body used, prohibited. Front air dams or spoilers permitted on street roadsters; may not project more than 30 inches ahead of front-spindle centerline. Any adjustment or movement during run prohibited. See General Regulations 7:1.

TOP

Top may be removed if car came with removable top. Convertibles may run with top down. Tops may be chopped on other cars.

WINDSCREEN

Convertibles and roadsters may remove windshield; mandatory on all others. Cars without a windshield must have a metal or other flame-proof windscreen installed. See General Regulations 7:7.

WINDSHIELD, WINDOWS

Cars with top and windshield must be equipped with all windows. All windshields and windows must be clear or factory-tinted safety glass or clear Plexiglas or other shatterproof material, 1/8-inch-minimum thickness. Identification decals permitted on rear quarter windows only. See General Regulations 7:1, 7.8.

ELECTRICAL: 8

BATTERIES

All batteries must be securely mounted with metal hold-downs outside the driver compartment. See General Regulations 8:1, 8:3, 8:4.

DELAY BOX/DEVICE

Permitted. See General Regulations 8:2.

IGNITION

Timed ignition-interruption devices (stutter boxes) prohibited. Starting-line and/or "high-side" rev limiters permitted. Two-steps, rev limiters, or any other rpm-limiting devices, legal unto themselves but altered or installed so as to function as a downtrack rpm controller, prohibited.

All wiring associated with the ignition system must be fully visible, labeled, and traceable. See General Regulations 8:3.

INSTRUMENTS

One tachometer allowed. No wiring (other than the two-step launch-control wire that splices into the transbrake or line-loc control wire) shall be connected directly or indirectly between any part of the ignition system and the delay box/device.

The use of mechanical- or electrical-driven speedometers prohibited.

MASTER CUTOFF

Mandatory on all cars with a battery. See General Regulations 8:4.

TAILLIGHT

One functional taillight mandatory. See General Regulations 8:6.

SUPPORT GROUP: 9**COMPUTER**

Prohibited. See General Regulations 9:1.

DATA RECORDER

One data recorder permitted. Wheel counters prohibited. Any drivetrain sensors permitted. See General Regulations 9:2.

FIRE-EXTINGUISHER SYSTEM

Permitted. See General Regulations 9:3.

TOW VEHICLES

Prohibited. See General Regulations 9:12.

WARM-UPS

See General Regulations 9:5, 9:14.

DRIVER: 10**ARM RESTRAINTS**

Mandatory in all open-bodied cars. See General Regulations 6:3, 10:3.

CREDENTIALS

Valid state- or government-issued driver's license beyond a learner's-permit level mandatory for cars running 10.00 (*6.40) or slower. All competitors at NHRA Mello Yello national events must be a minimum of 18 years of age. See General Regulations 10:4.

DRIVER LOCATION

Driver's torso must be positioned on the left or right side of the driveshaft in original location. Seat may be moved rearward, but driver must remain in front of differential.

DRIVER RESTRAINT SYSTEM

Driver restraint system meeting SFI Spec 16.1 or 16.5 mandatory. Restraint system must be updated at two-year intervals from date of manufacture. See General Regulations 10:5.

HEAD PROTECTOR

Mandatory. See General Regulations 10:6.

HELMET

For all closed-bodied cars, an open-face or a full-face Snell M2010, M2015, SA2010, or SA2015 helmet mandatory; shield permitted (goggles prohibited).

For all open-bodied supercharged, turbocharged, or naturally aspirated cars, a full-face Snell M2010, M2015, SA2010, or SA2015 helmet and shield mandatory (goggles prohibited). See General Regulations 10:7.

PROTECTIVE CLOTHING

Jacket and pants or suit meeting SFI Spec 3.2A/1 mandatory. Driver of any car faster than 135 mph, jacket and pants meeting SFI Spec 3.2A/5 and gloves meeting SFI Spec 3.3/1 mandatory, except when automatic transmission is located in driver compartment: jacket and pants or suit meeting SFI Spec 3.2A/15, gloves meeting SFI Spec 3.3/5, and boots or shoes meeting SFI Spec 3.3/5. See General Regulations 10:10.



SECTION 9 SUPER GAS

Requirements and specifications for Super Gas are the same as those for Super Street - Section 7 - with the following exceptions:

DESIGNATION

S/G, preceded by car number.

Super Gas cars race on a 9.90 standard (6.30 for eighth-mile tracks) using a heads-up, .4-second Pro Tree. Reserved for full-body cars with full fenders, hood, grille, top, windshield, and functional doors. Bumpers optional. Grille may be replaced by flat panel. Left-hand-steering street roadsters permitted. Open-wheel altered, dragsters, Funny Cars, and motorcycles prohibited. Minimum weight, including driver: 2,100 pounds, except 4-cylinder cars, 1,200 pounds.

REQUIREMENTS & SPECIFICATIONS

ENGINE: 1

OIL-RETENTION DEVICE

All vehicles must utilize an NHRA-accepted lower engine oil-retention device; may use a belly pan in lieu of a device attached to the engine. If belly pan is used, must extend from framerail to framerail and extend forward of the harmonic balancer and rearward to rear-engine plate and must incorporate a minimum 2-inch-high lip on all sides. A nonflammable, oil-absorbent liner mandatory inside of retention device. See General Regulations 1:8.

FUEL

Nitrous oxide prohibited, except on diesel-turbocharged engines.

DRIVETRAIN: 2

TRANSMISSION, AFTERMARKET PLANETARY

Transmission shield meeting SFI Spec 4.1 mandatory on any supercharged or turbocharged vehicle, or any vehicle burning methanol and equipped with aftermarket planetary transmission. See General Regulations 2:13.

TRANSMISSION, AUTOMATIC

Automatic transmission flexplate meeting SFI Spec 29.1 mandatory. See General Regulations 2:14.

TRANSMISSION SHIELD, AUTOMATIC

Automatic transmission flexplate shield meeting SFI Spec 30.1 mandatory. See General Regulations 2:14.

BRAKES & SUSPENSION: 3**BRAKES**

Two rear-wheel hydraulic brakes mandatory. See General Regulations 3:1.

SUSPENSION

Any automotive suspension permitted. Rigid-mount front axles permitted if wheelbase is 100 inches or longer. Rigid-mounted rear axles permitted. Any front suspension using a beam or tubular-type axle must have radius rods attached to frame. Radius rods not required on front axles rigidly mounted 18 inches or less from front kingpin axis. Shock absorbers optional. Rear suspension optional. See General Regulations 3:4.

FRAME: 4**ROLL CAGE**

Mandatory. Must conform to specs for body style used, as outlined in General Regulations 4:11. Any vehicle running 180 mph or faster must meet appropriate SFI Spec for body used. See General Regulations 4:4, 4:11, 10:6.

ROLL-CAGE PADDING

Roll-cage padding meeting SFI Spec 45.1 mandatory anywhere driver's helmet may come in contact with roll-cage components. See General Regulations 4:11, 10:6.

INTERIOR: 6**WINDOW NET**

A ribbon-type or SFI 27.1 mesh-type window net is mandatory for any full-bodied car. See General Regulations 6:3.

DRIVER: 10**ARM RESTRAINTS**

Mandatory in all open-bodied cars. See General Regulations 10:3.

CREDENTIALS

Valid NHRA competition license mandatory. All competitors at NHRA Mello Yello national events must be a minimum of 18 years of age. See General Regulations 10:4.

HELMET

For all closed-bodied cars, a full-face Snell M2010, M2015, SA2010, or SA2015 helmet mandatory; shield permitted (goggles prohibited).

For all open-bodied supercharged or turbocharged cars, a full-face Snell SA2010, or SA2015 helmet and shield mandatory (goggles prohibited).

For all open-bodied, naturally aspirated gasoline- or methanol-burning cars, a full-face Snell M2010, M2015, SA2010, or SA2015 helmet and shield mandatory (goggles prohibited). See General Regulations 10:7.

NECK COLLAR

Neck collar meeting SFI Spec 3.3 mandatory. See General Regulations 10:8.

PROTECTIVE CLOTHING

Jacket and pants meeting SFI Spec 3.2A/5 and gloves meeting SFI Spec 3.3/1 mandatory for all cars, except for vehicles,

supercharged or turbocharged with alcohol, or when automatic transmission is located in driver compartment: Jacket and pants or suit meeting SFI Spec 3.2A/15, gloves meeting SFI Spec 3.3/5, and boots or shoes meeting SFI Spec 3.3/5. For all open-bodied cars where the driver does not use an SFI 3.3 neck collar (driver who uses head and neck restraint system only), an SFI 3.3 head sock or SFI 3.3 skirted helmet mandatory. See General Regulations 10:10.



SECTION 10 SUPER COMP

S/C

Requirements and specifications for Super Comp are the same as those for Super Gas - Section 8 - with the following exceptions:

DESIGNATION

S/C, preceded by car number.

Super Comp cars race on an 8.90 standard (5.70 for eighth-mile tracks) using a heads-up, Pro Tree. Reserved for dragsters, alters, roadsters, Funny Cars, and Pro Stock-type cars. Motorcycles prohibited. Minimum weight, including driver: 1,350 pounds, except 4- and 6-cylinder cars, 1,000 pounds. Rear-engine dragsters utilizing naturally aspirated OEM motorcycle engines (maximum of four cylinders and a minimum of two cylinders) with OEM transmission, 700 pounds.

REQUIREMENTS & SPECIFICATIONS

ENGINE: 1

ENGINE

For rear-engine dragsters utilizing naturally aspirated OEM motorcycle engines, an SFI Spec 18.1 harmonic balancer is not required.

FUEL

Nitrous oxide prohibited, except on diesel-turbocharged engines.

DRIVETRAIN: 2

CLUTCH, FLYWHEEL, FLYWHEEL SHIELD, CHAIN GUARD

For rear-engine dragsters utilizing naturally aspirated OEM

motorcycle engines, an aftermarket billet flywheel or NHRA-accepted flywheel shield mandatory. Stock steel or cast aluminum flywheel prohibited. Keyway modifications permitted. Centrifugal, slider, or conventional motorcycle clutch permitted. Chain guard mandatory, must cover the width and at least the top run to the forward and trailing centerline of the sprockets on any chains. Chain guard must be a minimum of .060-inch steel or .090-inch aluminum and must be within 4 inches of the chain at all points. Belt drive permitted.

TRANSMISSION

For rear-engine dragsters utilizing naturally aspirated OEM motorcycle engines with OEM transmission, the transmission may be shifted with a preset timed or preset rpm-activated electrical, mechanical, pneumatic, hydraulic device, or by standard OEM operation. Rpm-based automatic shifters may not have a time delay incorporated into the device. Rpm-based automatic shifters may not be connected (directly or indirectly) to the delay box/device. Time-based automatic shifters may not be connected (directly or indirectly) to the ignition system. Reverse gear optional for rear-engine dragsters utilizing naturally aspirated OEM motorcycle engines with OEM transmission.

BRAKES & SUSPENSION: 3

BRAKES

With a total car weight of 1,000 pounds or less and a one-piece rear axle, may use a single brake rotor with dual calipers. See General Regulations 3:1.

STEERING

Butterfly steering wheel permitted only on front- or rear-engine dragsters and altered. See General Regulations 3:3.

TRACTION BAR ROD ENDS

Must use 3/4-inch-minimum steel rod ends on front of all ladder and/or four-link bars. See General Regulations 3:5.

FRAME: 4

DEFLECTOR PLATE

Must be installed between roll cage and engine on all rear-engine cars to protect driver and fuel tank. Minimum material thickness: 1/8-inch aluminum or .060-inch steel. See General Regulations 4:3.

PINION SUPPORT

Mandatory on all front-engine cars. See General Regulations 4:9.

WHEELBASE & TREAD WIDTH

Minimum 90 inches. Maximum wheelbase variation from left to right: 2 inches. Minimum front tread width 26 inches on any dragster.

TIRES & WHEELS: 5

TIRES

Minimum diameter of 13 inches on front tires of any dragster. See General Regulations 5:1.

WHEELS

Wire wheels permitted on front of dragsters only, provided total weight of car does not exceed 1,800 pounds, excluding driver. Minimum diameter on front wheel, 5 inches. See General Regulations 5:2.

BODY: 7

AIR FOILS

Permitted. Aftermarket front spoiler or air dam may not project

more than 30 inches ahead of front-spindle centerline. See General Regulations 7:1.

BODY

Body and cowl must be metal, fiberglass, or carbon fiber and must extend to firewall. Driver compartment, frame structure, roll cage, and body must be designed to prevent driver's body or limbs from making contact with wheels, tires, exhaust system, or track surface. If driver's body is in contact with belly pan, a crossmember and subfloor are mandatory. On full-bodied cars, hood scoop may not extend more than 11 inches above height of original hood surface. On open-bodied, front-engine cars, hood scoop may not extend more than 11 inches above height of carburetor top.

FENDERS

Mandatory on full-bodied cars. See General Regulations 7:3.

SPOILERS/WINGS

Non-OEM airfoils or wings permitted; must be permanently attached to frame or roll cage, nonadjustable during run.

SUPPORT GROUP: 9**PUSH BAR**

Push bar must be designed to prevent push car from riding up on rear wheels.

TOW VEHICLES

Three- or four-wheeled, Quadrunner/ATV-type tow vehicle permitted. Full-size tow vehicle prohibited. See General Regulations 9:12.



SECTION 11 STOCK

Category is based on a handicap start using the NHRA index system; breakout rules apply. Note: For more information on the Automatic Horsepower Factoring System, visit NHRARacer.com.

SECTION 11A STOCK CARS

DESIGNATIONS

FS/AA, FS/A, FS/B, FS/C, FS/D, FS/E, FS/F, FS/G, FS/H, FS/I, FS/J, FS/K, FS/L, AA/S, A/S, B/S, C/S, D/S, E/S, F/S, G/S, H/S, I/S, J/S, K/S, L/S, M/S, N/S, O/S, P/S, Q/S, R/S, T/S, U/S, V/S, and W/S (manual transmission), preceded by car number. AA/SA, A/SA, B/SA, C/SA, D/SA, E/SA, F/SA, G/SA, H/SA, I/SA, J/SA, K/SA, L/SA, M/SA, N/SA, O/SA, P/SA, Q/SA, R/SA, T/SA, U/SA, V/SA, and W/SA (automatic transmission), preceded by car number. AAF/S, AF/S, BF/S, CF/S, DF/S, and EF/S (front-wheel-drive), preceded by car number.

Reserved for 1955 or newer model-year factory-production automobiles and some sports cars. Classified per NHRA performance rating as listed in the Official NHRA Stock Car Classification Guide. Only those cars listed in the guide are eligible for competition. All cars in Stock classes must be factory-production assembled, showroom available, and in the hands of the general public. A minimum 500 units of a particular body style must be produced.

OEM may apply for inclusion of any special production runs into the Official NHRA Stock Car Classification Guide. Special run must include a minimum of 50 units of an already accepted body style, need not be showroom available. Applications evaluated on an individual basis. Acceptance will not imply precedent.

CLASS WEIGHT BREAKS

(based on pounds per NHRA-factored horsepower)

FS/AA: 5:50 to 5:99	A: 8.00 to 8.49	O: 15.00 to 15.99
FS/A: 6.00 to 6.49	B: 8.50 to 8.99	P: 16.00 to 16.99
FS/B: 6.50 to 6.99	C: 9.00 to 9.49	Q: 17.00 to 17.99
FS/C: 7.00 to 7.49	D: 9.50 to 9.99	R: 18.00 to 18.99
FS/D: 7.50 to 7.99	E: 10.00 to 10.49	T: 19.00 to 19.99
FS/E: 8.00 to 8.49	F: 10.50 to 10.99	U: 20.00 or more
FS/F: 8.50 to 8.99	G: 11.00 to 11.49	V: 22.00 or more
FS/G: 9.00 to 9.49	H: 11.50 to 11.99	W: 24.00 or more
FS/H: 9.50 to 9.99	I: 12.00 to 12.49	AAF: 11.00 to 12.99
FS/I: 10.00 to 10.49	J: 12.50 to 12.99	AF: 13.00 to 15.99
FS/J: 10.50 to 10.99	K: 13.00 to 13.49	BF: 16.00 to 17.49
FS/K: 11.00 to 11.49	L: 13.50 to 13.99	CF: 17.50 to 18.99
FS/L: 11.50 or more	M: 14.00 to 14.49	DF: 19.00 to 24.99
AA: 7.50 to 7.99	N: 14.50 to 14.99	EF: 25.00 or more

Class V restricted to 4- or 6-cylinder cars only. Class W restricted to 4-cylinder cars only. Front-wheel-drive vehicles restricted to 4-, 6-, or 8-cylinder; 1978 or newer cars only. Front-wheel-drive standard-transmission vehicles must add 100 pounds to class minimum. The power-to-weight factor (as found in the Official NHRA Stock Car Classification Guide) determines the natural class for all cars. The power-to-weight factor is the shipping weight of the vehicle divided by the advertised, or when applicable, the factored horsepower for the OEM-assembly-line cylinder heads (not aftermarket cylinder heads). NHRA-accepted aftermarket cylinder-heads carry a horsepower penalty that is calculated to the weight of the vehicle and does not change the class of the vehicle.

2008 and newer Chevrolet COPO, Dodge Drag Pak, and Ford Cobra Jet (automatic and manual) restricted to FS/AA through FS/L.

Any competitor who causes an oil-down while participating at an NHRA Mello Yello event will be subject to fines and penalties as outlined in Section 2 - Oil-down Penalties.

REQUIREMENTS & SPECIFICATIONS

ENGINE: 1

AIR CLEANERS

Optional. If used, air cleaner must be OEM automotive or retain OEM configuration. Air-cleaner base may be cut or trimmed, but welding, bolting, riveting, epoxying, or any other form of fabrication is prohibited. Ram tubes, velocity stacks, or non-stock-type base plates or ducting prohibited. Cooling holes prohibited in radiator side panels, etc. Factory air cleaners and/or scoops that fit through hood must be affixed to carburetor as per OEM only.

BLUEPRINTING

Permitted per NHRA Specifications available from NHRA Technical Services Department headquarters. Stock factory OEM components (unless otherwise specified) must be retained and remain unaltered (i.e., connecting rods, pushrods, crankshaft, etc.).

CAMSHAFT/LIFTERS

Camshaft must retain stock lift for horsepower claimed per NHRA Technical Bulletins. Front-wheel-drive vehicles and stock trucks, maximum lift is limited to .430-inch or OEM, whichever is greater. Aftermarket replacement lifters permitted. Solid lifter may replace hydraulic. Flat tappet may not be replaced with roller. Lift checked at valve retainer, with zero lash. Hydraulic lifter cam will be checked with pushrod and rocker as run, plus solid lifter, at zero lash. Plunger height of checking lifter will match extended height (no preload) of hydraulic lifter. Hydraulic lifter may not be plugged or bottomed. Aftermarket gear drives/belts prohibited. Aftermarket timing covers permitted as long as OEM-type timing gears are used. Adjustable pushrods or adjustable OEM rocker arms (not both) permitted; must be same or greater weight as stock. Pushrod guide plates permitted. Cylinder head may be clearanced for larger-diameter pushrods.

CARBURETOR

Must be correct year, make, and model specified for car's engine; fuel or air bleed passages may be resized. Drilling idle holes in primary throttle blades permitted. Other modifications prohibited. Sandblasting, grinding, flash removal, dry film coating, or any other modification to carburetors prohibited. Replacement carburetors permitted provided they are same model, type, throttle bore, and venturi size. Computer carburetors use latest model non-computer carb for engine application.

CONNECTING RODS

Stock OEM or NHRA-accepted aftermarket rods permitted. NHRA-accepted aftermarket rods must meet specifications as found on the then-current NHRA Stock & Super Stock Replacement Rod Acceptance List. The combined weight of the piston, pin, rings, and connecting rod must be equal to or greater than the Minimum Assembly Weight as found on the then-current Stock Replacement Piston Acceptance List. Accepted replacements are published on NHRARacer.com. Grinding and polishing permitted on beams only. Shot-peening of connecting rods permitted. Length must be stock +/- .025-inch center to center. The use of rod and crank spacer bearings prohibited. Cylinder block housing bore size and rod bore housing size must maintain sizes as designated per NHRA's then-current approved rod listing.

CYLINDER HEADS

Must be correct casting number for year and horsepower claimed, per NHRA Technical Bulletins or NHRA accepted. Porting, polishing, welding, epoxying and acid-porting prohibited. Combustion-chamber modifications prohibited. Cylinder heads are additionally restricted in that they must retain original-size valves at original angles +/- 1 degree and must be able to hold original cylinder-head volume per NHRA Specifications. Runner volumes may not exceed the current Super Stock cylinder-head volumes as listed on www.NHRARacer.com. Regardless of the poured volume measurement, any modifications to intake or exhaust runners prohibited. Any evidence of modifications from the original castings will be grounds for disqualifications as determined by NHRA in NHRA's sole and absolute discretion. Any aftermarket steel valve permitted, must retain stock head and stem diameters. Only engines OEM-equipped with sodium-filled valves may use sodium-filled replacement valves. Titanium prohibited. Hardened keepers permitted. Lash caps prohibited. Valve-diameter tolerance: +.005-inch or -.015-inch from NHRA Specs. The following are prohibited: spark-plug adapters; any grinding in ports or combustion chambers; removal of any flashings; sandblasting or any other modification to cylinder head; any film coating of intake and exhaust runners; any film coating of combustion chamber. Runners and combustion chamber must retain OEM appearance. Final acceptance as determined by NHRA in NHRA's sole and absolute discretion. External modifications prohibited. Intake side of head may not be cut into any part of valve cover bolt holes. Valve-cover bolt holes must remain unaltered and in their original location. Heat riser passage may be blocked from intake manifold side of cylinder head. Blocking passage down in valve pocket prohibited. The following are permitted: polylocks, jam nuts, screw-in larger-diameter rocker studs or pinned studs, bronze-wall valve guides, cylinder head studs. Valve spring umbrellas optional. Cylinder head may have all of the seats replaced. Any valve job permitted, O-ringing prohibited. Exhaust plates prohibited.

ENGINE

Must be same year and make as car used, aftermarket NHRA-accepted cylinder blocks permitted. Equipment other than original factory-installed prohibited. Any special equipment export kit (superchargers, dealer-installed options, etc.) automatically disqualifies car. Engine must remain in stock location — height, setback, etc. Cylinder bores must not exceed .080-inch over stock. Bores are measured at top of cylinder where ring wear is not evident. Crossbreeding parts prohibited. Normal balance job (i.e., one piston/rod assembly untouched) permitted. Otherwise lightening of component parts prohibited. All carburetors, manifolds, heads, etc. must be tightened to prevent any air or fuel leaks. Vacuum lines must be securely connected or blocked off. Stroke tolerance is +/- .015-inch. Stock OEM or NHRA

accepted aftermarket crankshaft mandatory. Aftermarket crank must retain OEM configuration (i.e., knife edging, etc. prohibited). Billet crankshafts prohibited, unless OEM equipped. Lightening of crankshaft other than normal balance job prohibited. Cylinder blocks may be sleeved. Aftermarket SFI Spec 18.1 harmonic balancer mandatory in AAA/S through G/S and AAA/SA through G/SA and all FS classes. See General Regulations 1:2.

SUPERSEDED AND/OR REPLACEMENT PARTS

Superseded parts are restricted to cylinder heads, intake manifold, crankshaft, cylinder block, and transmission only when manufacturer lists such parts in its published parts book, notifies NHRA of said change, and change is accepted by NHRA.

EXHAUST SYSTEM

Optional. Adaptor plates, port plates, and header plates prohibited. Pan evacuation systems prohibited. Turbo applications, aftermarket header permitted – turbo must be located in engine compartment. Mufflers and/or maximum decibel levels may be enforced at certain facilities, according to any local ordinances that may be in effect. Contact individual tracks for more information. See General Regulations 1:3.

FAN, GENERATOR, WATER PUMP

Alternator or generator must be engine-driven and functioning. Belt must be tight enough to drive equipment in a satisfactory manner without excessive or noticeable slippage. May be relocated. Aftermarket pulleys permitted. Electrically driven fans and water pumps permitted. Water pump must bolt on, with no modifications to block. Use of “smog pump” or air pump for crankcase evacuation prohibited.

FUEL

NHRA-accepted racing gasoline only. Propylene oxide and/or nitrous oxide prohibited. See General Regulations 1:6.

FUEL INJECTION

Electronic fuel injection permitted. Fuel injection must retain OEM throttle body(s), plenum, and manifold. If OEM throttle body(s) was equipped with electronic throttle control (i.e., drive by wire), the throttle body(s) may be adapted to mechanical throttle linkage if an aftermarket OEM-type electronic-fuel-injection system is used. Larger fuel injectors permitted, provided no modification or redrilling of manifolds is performed. Open-loop systems permitted on production vehicles as equipped with OEM electronic fuel injection. See General Regulations 9:1, 9:11.

FUEL SYSTEM

Any mechanical fuel pump and/or one electric fuel pump permitted. Must be installed outside of passenger area, away from tires and suspension. Electric pump must shut off with car's ignition switch. Fuel lines may be changed to any size metallic line with in-line fuel filters and pressure regulators permitted; a maximum 12 inches of rubber lines for vibration connections are permitted. One cool can permitted. All fuel system components (regulators, cool cans, etc.) must be installed not less than 6 inches in front of firewall. Exception: Fuel-pressure-gauge isolators, with steel-braided line, may be mounted on firewall. See General Regulations 1:5.

GASKETS

Any replacement or aftermarket gasket permitted. If thinner-than-stock head gaskets are used, thickness loss must be made up with additional deck clearance. Difference in deck clearance can also be made up using thicker-than-stock head gaskets. Carburetor heat-insulator-type gaskets prohibited. Maximum of two stock-type gaskets permitted.

GAS TANK

Must be correct year, make, and model for car used, with stock

fuel inlet and outlet locations. Must be in stock location; fuel line and pickup may be resized. Fuel cell permitted; maximum capacity 16 gallons. If fuel cell is used, OEM gas tank must be removed, and a firewall of minimum .032-inch aluminum or .024-inch steel must be installed to totally seal driver compartment from fuel cell. Trunk floor may be modified to accommodate fuel-cell sump. Where OEM gas tank is in the trunk floor, area occupied by OEM tank may be replaced with material equal to or heavier than OEM floor. If OEM gas tank is used, it must remain unaltered.

INTAKE MANIFOLD

Must retain the unaltered stock manifold, consistent with year and engine horsepower claimed. Grinding, sandblasting, or any other modification to manifold prohibited. Any film coating inside manifold prohibited. Runners and plenum must retain OEM appearance. Final acceptance at the discretion of the NHRA Technical Services Department.

INTERCOOLER

Intercooler tanks must be located in the engine compartment.

OIL PAN

OEM or NHRA-accepted aftermarket replacement oil pan permitted. Windage trays and/or baffles permitted. Modifications of any kind prohibited. Crossmember may be altered for oil pan removal. If altered, all material and strength must be replaced by boxing or installing removable or permanent material.

OIL PUMP

Stock, OEM, or OEM-type aftermarket oil pump permitted. Oil pump location, oil pump drive, and complete oiling system must remain as originally produced, Accumulator permitted. Additional external plumbing prohibited. Dry-sump system prohibited.

PISTONS

OEM or NHRA-accepted aftermarket replacements permitted provided such items comply with all requirements set forth in this section. Aftermarket pistons may be forged or cast and must retain the as-cast or as-forged head configuration. The manufacturer or ID number must remain unaltered and fully visible to determine correct application. Piston may not be remachined for special rings, deck height adjustment, valve relief size, depth, location, or to modify dome or dish. Piston must be of the same overall design with the same dome/dish configuration as OEM piston with the correct number, location, depth, and width of ring grooves. Valve relief and head land modifications to aftermarket or OEM pistons prohibited. Assembly weight must be equal to or greater than the minimum assembly weight as found on the then-current Stock Replacement Piston Acceptance List. Any steel pin of OEM diameter permitted. Any lightening of pistons beyond that necessary for normal balancing is strictly prohibited. Gas porting of pistons prohibited. Piston may be installed with arrow in either direction. NHRA-accepted aftermarket pistons and weights are published on NHRARacer.com.

RADIATOR

Full-size stock radiator mandatory for body used. Aluminum radiators permitted; must retain stock dimensions and appearance. Cutting, denting, or elimination of any body, fender, radiator, or grille panels prohibited.

ROCKER ARMS

OEM or aftermarket rocker arm permitted. Needle/roller bearing pivots and roller tips are permitted for all applications. Must remain same design as original application (i.e., stud mount must retain stud mount, pedestal type must retain pedestal type, and shaft type must retain shaft type. Stud girdles prohibited.) Stamped steel OEM and OEM-type rocker arms may be reinforced.

SPARK PLUGS

Any type spark plug or ignition wiring manufactured for automotive use permitted.

THROTTLE LINKAGE

Any progressive or other positive-action throttle or choke linkage permitted. Converting from drive by wire to mechanical throttle body permitted, providing they are the same type and throttle bore size. See General Regulations 1:12.

TORQUE STRAP

Permitted. Must be on one side of engine only.

TURBOCHARGERS

Turbocharger size will be verified by measuring the housing bore at the leading edge of the impeller wheel. The maximum diameter of the housing bore at the leading edge of the wheel may not exceed 2mm more than the maximum allowable turbocharger size permitted.

VALVE COVERS

Aftermarket valve covers permitted.

VALVE SPRINGS

Any valve spring permitted, provided no modification to head is performed. Steel valve-spring retainers mandatory. Spring cups permitted ONLY if no modification to head is required; otherwise prohibited.

DRIVETRAIN: 2**CLUTCH, FLYWHEEL, FLYWHEEL SHIELD**

Clutch and flywheel meeting SFI Spec 1.1 or 1.2 (2-disc maximum) mandatory. Steel flywheel shield meeting SFI Spec 6.1 mandatory on all V-8 cars with a clutch. Flywheel shield cannot be modified for clutch adjustment and/or cooling holes. See General Regulations 2:3, 2:5, 2:6, 2:10.

DRIVELINE

Aluminum driveshaft prohibited except OEM. Carbon fiber driveshaft prohibited. Driveline loop mandatory in all rear-wheel-drive cars. See General Regulations 2:4.

REAR END

Original rear end may be replaced with another from the same automobile manufacturer; truck rear end prohibited. Aluminum center section permitted only on vehicles that were originally equipped with same. Distance between backing plates may not be changed. Any gear ratio that fits third-member case or housing permitted. Limited-slip or ratchet-type rear ends permitted. Reinforcement of spring perch permitted. Spools permitted only with aftermarket axles. Aftermarket axles not required for front-wheel-drive vehicles. Larger brakes may be used. Replacement rear end may be narrowed or widened to obtain original rear-end width. Bracing or beefing up the rear-end housing permitted.

Swing axle differential may be replaced with conventional housing; 9-inch housing permitted in 2008 and newer vehicles; stock trailing arms must be retained, may be beefed up and adapted to housing, must retain transverse spring. Must install Panhard bar. Frame may be notched for driveshaft clearance. Distance between OEM backing plates and OEM wheelbase must be maintained. Coil-over shock or four-link adaptations prohibited. See General Regulations 2:11.

TRANSMISSION, AUTOMATIC

Any model transmission, same make as car, with a maximum of three forward speeds (unless OEM equipped with more than three forward speeds). O.D. gear not required, reverse permitted. Transmission case must be OEM or aftermarket OEM replica from a standard, automotive application as found in the Official NHRA

Stock Car Classification Guide. Aftermarket case must meet SFI Spec. 4.1. NHRA-accepted adapter plates permitted. Modifications to shifting patterns are permitted, provided full shift pattern is retained. Full shift pattern must include park and reverse. Any gear change must occur as a result of an internal function of the transmission or from direct action by the driver. Lockup converter permitted if OEM-equipped with lockup converter and OEM transmission is used. Otherwise, lockup converters prohibited. Electronic transmission controls for the electric shifting of automatic transmissions to shift via internal function of the valve body only permitted in computer-controlled vehicles only; may shift by RPM or time only, wires for line lock, wheel speed, driveshaft speed or GPS signal prohibited. Otherwise, any gear change must occur as a result of an internal function of the transmission or from direct action by the driver. Pneumatic, electric, etc. controls in all noncomputer-controlled electronic-fuel-injected vehicles prohibited. The use of air assisted or electric shifter is prohibited in all Stock applications. Deepened stock or aftermarket transmission oil pans permitted. Drilling of transmission case or rear of engine block to adapt incompatible units prohibited. Functional neutral safety switch mandatory. Transmission brake prohibited. Tailshaft modifications for bushing replacement, or NHRA-accepted aftermarket tailshaft, permitted. Any car running quicker than 10.99 must be equipped with a transmission shield meeting SFI Spec 4.1. Any car running quicker than 9.99, SFI 29.1 automatic transmission flexplate and SFI 30.1 flexplate shield mandatory. See General Regulations 2:12, 2:14.

TRANSMISSION, MANUAL

OEM or NHRA-accepted aftermarket transmissions having same number of forward speeds (O.D. gear not required) as original, and reverse, may be used. All gear changes must result from direct action by the driver. Pneumatic, hydraulic, electric, etc. shifters prohibited. Floor-shift conversion kits permitted. Clutchless transmissions prohibited. Clutch must be used to change gears in a conventional manner. If any engine/manual transmission combination is listed in the class blueprint specification as being available with only a three-speed manual transmission, it may be replaced with any four-speed manual transmission. See General Regulations 2:12.

BRAKES & SUSPENSION: 3

BRAKES

Must be equipped with stock production four-wheel hydraulic brake system, or aftermarket disc brakes meeting the following criteria:

1. Minimum effective piston area per wheel: 3 1/2 square inches.
2. Minimum disc (rotor) diameter 10 1/4 inches x 5/16-inch thick.
3. Must install dual reservoir master cylinder with any modified brake system, splitting front and rear into separate systems.
4. Dual calipers on rear wheels permitted, maximum one hydraulic brake line to dual rear brake system (no wires).
5. Rear-wheel line-loc prohibited; front-wheel line-loc permitted. Parking brake optional.
6. Carbon-fiber and titanium brake rotors prohibited. See General Regulations 3:1.

Four-wheel or rear-wheel line-loc prohibited. All line-locs must be spring-loaded or self-returning to normal operating mode.

POWER STEERING

May be removed or converted to manual steering. See General Regulations 3:3.

SHOCKS

No pneumatic or electric shocks permitted unless such items were OEM equipment. No additional reservoirs allowed.

SUSPENSION, FRONT

Must retain complete stock front suspension system as produced by manufacturer for body used, aftermarket tie rods with Heim joints permitted. Lower control arm may be machined for larger shock diameter and mount. Lift kits/travel limiters prohibited. Sway bar optional. See General Regulations 3:4.

SUSPENSION, REAR

Must remain as produced, except for the following: Leaves may be changed (added or subtracted) as long as overall length and mounting points are used. Coils may be changed (clamped or spaced) as long as stock mounting points are maintained. Solid bushings in rear suspension permitted. Cars with rear coil springs may relocate the upper control arm at rear-end attachment point. Rear trailing arms may be replaced with NHRA-accepted OEM-type aftermarket units. Aftermarket lower unit must be non-adjustable and have bushed ends (no heims). Aftermarket upper unit may be adjustable and use heim ends instead of bushings. Sway bar(s) optional. OEM or aftermarket torque arm permitted only on vehicles OEM-equipped with a torque arm. OEM torque-arm attachment points at rear end must be retained. See General Regulations 3:4.

TRACTION BARS

Traction bars or pinion snubbers permitted. Shock absorbers, springs, or any other stock suspension component may not be moved or altered for any traction-bar installation except those traction bars that are equipped with a new spring perch. Bolt-on traction devices permitted, provided front mounting point is no farther forward than stock front spring eye of leaf-spring-equipped cars, or stock front mounting point for control arms on coil-spring-equipped cars. Device must be installed under leaf spring and bolt to leaf-spring attaching point in rear. Traction bars and/or mounting brackets (to rear axle housing) may not be lower than lowest edge of rear-wheel rim. Weld-on traction bars, ladder bars, or wheelie bars prohibited. AF through EF may add traction devices as necessary. See General Regulations 3:5.

WHEELIE BARS

Permitted. Wheelie-bar brackets may be welded to rear-axle housing; bars and associated brackets must be stand-alone items and not attached to any suspension or other components. Maximum length 48 inches or to rear bumper, whichever is greater. Trunk floor may be notched for wheelie-bar clearance. See General Regulations 3:6.

FRAME: 4**BALLAST**

Weight box permitted. Only 100 pounds removable ballast permitted, including box (two-box maximum with 50 pounds each). Must be attached to frame or crossmember with minimum of two 1/2-inch bolts. May not be attached to roll bar or cage. Additional ballast must be permanently attached to frame or crossmember, i.e., bolted with at least two 1/2-inch bolts per 100 pounds, with nut welded to bolt. See WEIGHT. See General Regulations 4:2.

BUMPERS

Complete stock bumpers, guards, and braces (front and rear) mandatory, consistent with make, model, year claimed. Rear bumpers, guards, and braces optional on stock trucks. Energy-absorbing apparatus may not be removed.

Rear bumper cover or valance only (i.e., not the bumper) may be notched or slotted for clearance around wheelie bars. Opening maximum is to allow for wheelie-bar movement only. Removal of

rear bumper cover or trimming rear bumper cover the full width of wheelie bar prohibited.

FRAME

Frame or subframe must be stock for body used. Subframes on unibody cars may be joined. Maximum-size material to be used is 2 inches x 3 inches x 1/8-inch. Round tubing may be used to tie front and rear subframes together and join subframe in straight line extending through car floor, with floor completely welded to member.

GROUND CLEARANCE

Minimum 3 inches from front of car to 12 inches behind centerline of front axle; 2 inches for remainder of car, except oil pan and exhaust headers. See General Regulations 4:5.

MOTOR MOUNTS

May be replaced with steel units designed to eliminate rubber section of stock mounts. Engine must be in stock location — height, setback, etc. Motor plates and mid mounts prohibited.

PARACHUTE

Mandatory on any car that runs 150 mph or faster. See General Regulations 4:8.

ROLL BARS

Mandatory in AA/S through M/S, AA/SA through M/SA, FS/AA through FS/L, in all convertibles and in any car running 11.49 or quicker, permitted in slower cars. Front braces may not extend in front of firewall. Six-point attachments permitted. Roll cage mandatory in any car running 9.99 or quicker, permitted in slower vehicles. See General Regulations 4:10, 4:11, 6:3.

ROLL CAGE

Mandatory in any car running 9.99 or quicker. Roll cage meeting SFI 25.4 or 25.5 is mandatory for all Stock cars running 8.49 or quicker. See General Regulations 4:4, 4:11, 10:6.

ROLL-CAGE PADDING

Roll-cage padding meeting SFI Spec 45.1 mandatory on any vehicle running 9.99 and quicker. Padding must be used anywhere driver's helmet may come in contact with roll-cage components. See General Regulations 4:11, 10:6.

WEIGHT

All cars will be permitted to run on the class minimum weight, but may be no heavier than the minimum for the next heavier class. Car can move up (lighter) one class or down (heavier) one class. If weight is added, must be properly attached; see BALLAST. Class and classification weight are determined without driver weight. Once classification weight is calculated, 170 pounds is added for driver to arrive at total weight. All cars are weighed with driver.

WHEELBASE

Must retain stock wheelbase, +/- 3/4-inch for car body used per manufacturer's nominal specifications. Maximum variation from left to right: 1 inch. Any alteration to wheelbase, front and/or rear overhang, or relocation of wheel and/or axle location prohibited. See General Regulations 4:12.

TIRES & WHEELS: 5

TIRES

Street-type or drag slick tires, maximum 9-inch tread width. Tires may not be altered from tire manufacturer's original design or pattern. Size of tire (new) must not exceed 9-inch wide x 30-inch diameter (94-inch circumference). Tires may not exceed 10 inches wide regardless of wear. Front tires must have a full street pattern and must measure a minimum of 4 1/2 inches on ground. Tire

tread may not extend outside fender; maximum clearance between side wall and body is 3 inches. Slicks permitted on FWD cars. All-wheel-drive vehicles must have treaded front tires. Recapped/retreaded tires prohibited. See General Regulations 5:1.

WHEELS

Aftermarket racing wheels permitted. Automotive wire wheels or motorcycle wheels prohibited. Any wheel/tire combination may be used that does not require alterations to wheelwells. Minimum wheel diameter: 14 inches, unless factory equipped with smaller wheels. See General Regulations 5:2.

INTERIOR: 6

STEERING WHEELS

Aftermarket steering wheels permitted, minimum diameter 11 inches. Removable steering wheels permitted. Lengthening of steering column prohibited. Must maintain OEM length.

UPHOLSTERY

Must have full factory-type upholstery for year/model claimed, including factory-type floor mats or carpet, door panels and headliner, and front and rear seats. Interior gutting prohibited. Driver's seat tracks may be bolted down. Sun visors optional. Rear seat may be removed when roll bar is installed; area must be carpeted or upholstered equivalent to factory specifications (no bare paneling). Full-size aftermarket or corporate OEM front seats permitted; must be upholstered and supported. If a full-sized corporate OEM driver's seat is used, the passenger seat must be identical in appearance to the driver's seat. If a full-sized aftermarket driver's seat is used, the passenger seat must be full-sized and identical in appearance to the driver's seat being used or must be a full-sized corporate OEM passenger seat. See General Regulations 6:2.

WINDOW NET

A ribbon-type or SFI 27.1 mesh-type window net is mandatory in vehicle requiring a roll cage. See General Regulations 6:3.

BODY: 7

BODY

Alterations or customizing prohibited; extent of customizing is limited to paint only. Convertible-top cars must run with top up. Sedan delivery, Ranchero, El Camino, etc. (if found properly classified in the Classification Guide) are eligible only if all class requirements are met. Raising and/or lowering front or rear of cars prohibited. Cars must retain level attitude at standstill, except those that have a forward rake (a permitted modification). Bottom of rocker panel cannot be higher than centerline of rear axle. Body mount insulators may be replaced with solid mounts of same size. Aluminum or other lightweight material may not be used to replace heavier items on car. In front-wheel-drive vehicles, air dams and spoilers that were available through the manufacturer are permitted front and rear.

FENDERS

Leading and trailing edges of fenders may be trimmed for tire clearance, maximum 2 inches. See General Regulations 7:3.

FENDER SPLASH PANS

Mandatory. Can be trimmed to allow a maximum of 2 inches clearance around headers.

FIREWALL

Alterations prohibited unless expressly permitted in this section. Firewall coverings prohibited. Where heater/air conditioning units have been removed, area must be covered with minimum .024-inch steel or .032-inch aluminum, including rear hood seal/

flange, as on GM A-body. Minor firewall modifications permitted to C5 and C6 Corvettes for transmission installation. Roll cage tubing may run across top or side of inner fender well/strut tower and attach to frame horn. See General Regulations 7:4.

FLOOR

Complete stock floor, in stock location, mandatory.

GRILLE

Must be full production for make, model, and year claimed. Covering in front or behind grille prohibited.

HOOD

Full stock hood including latches, hinges, springs, brackets, and braces as originally produced must be retained. Hood openings and/or hood scoops other than original equipment prohibited. OEM hood openings must retain all flappers, grilles, hardware, etc. as originally produced. In front-wheel-drive vehicles, nonfunctional hood scoops that were available through the manufacturer are permitted.

STREET EQUIPMENT

The following are not required and may be removed: windshield-wiper blades, arms, and motor; heater/air conditioning and associated plumbing (controls must remain in dash; see INSTRUMENTS). Turn signals, etc. need not be operative. One working headlight and one working taillight mandatory.

WINDSHIELD, WINDOWS

All windows and windshields must be clear except for factory-tinted safety glass, and be in good condition. Windows must be operative, but closed during competition. Factory back glass on a truck may be replaced with Plexiglas, Lexan, or other shatterproof material, minimum 1/8-inch thick, to permit the use of the back brace bars on a roll bar or roll cage. See General Regulations 7:8.

ELECTRICAL: 8

BATTERIES

Must remain in stock location and be of sufficient capacity to start car at any time. Second battery permitted if securely mounted in trunk. Must be automotive type. Both batteries must be same type, size, and weight. See General Regulations 8:1.

DELAY BOXES/DEVICES

Prohibited. See General Regulations 8:2.

DISTRIBUTOR

Any battery-operated, stock-type ignition permitted. Crank trigger systems prohibited unless OEM distributorless ignition. Distributorless ignition must retain OEM number of coils. See General Regulations 8:3.

IGNITION, AUTOMATIC

Two-step permitted. Two-step must be foot-activated through brake pedal, clutch pedal, or pressure switch. Hand release prohibited. All wiring associated with the ignition system must be fully visible, labeled, and traceable. See General Regulations 8:3.

INSTRUMENTS

Full stock dashboard, including instruments, fresh-air ducts, and controls, must be retained. Heaters/air conditioners may be removed; controls must remain in dashboard. Tachometer, pressure gauges, etc. optional. See General Regulations 8:8.

MASTER CUTOFF

Mandatory on all cars with battery in the trunk. See General Regulations 8:4.

STARTERS

Aftermarket starters, in stock location, permitted. See General Regulations 8:5.

SUPPORT GROUP: 9**COMPUTER/DATA RECORDERS**

Original OEM computer may be replaced with aftermarket computer. Data recorders permitted. Other than OEM or OEM-replacement computers prohibited. See General Regulations 9:1, 9:2.

TOW VEHICLES

Prohibited.

WARM-UPS

See General Regulations 9:5, 9:14.

DRIVER: 10**CREDENTIALS**

Valid NHRA competition license mandatory for cars running 9.99 (*6.39) or quicker. Valid state- or government-issued driver's license beyond a learner's-permit level mandatory for cars running 10.00 (*6.40) or slower. All competitors at NHRA Mello Yello national events must be a minimum of 18 years of age. See General Regulations 10:4.

DRIVER

Must be in stock location with no part of the driver's head behind the "B" post. Revision of seat location prohibited.

DRIVER RESTRAINT SYSTEM

Driver restraint system meeting SFI Spec 16.1, including crotch strap, mandatory in classes AA/S through M/S, AA/SA through M/SA, FS/AA through FS/L, all convertibles, and in any car running 11.49 or quicker. Restraint system must be updated at two-year intervals from date of manufacture. See General Regulations 10:5.

DRIVER WEIGHT

All cars are weighed with driver; 170 pounds shall be added to car's classification weight, for driver, to arrive at minimum weight.

HELMET

For all 10.00 and slower cars, either an open-face or a full-face Snell M2010, M2015, SA2010, or SA2015 helmet mandatory; shield permitted (goggles prohibited).

For all 9.99 and quicker cars, a full-face Snell M2010, M2015, SA2010, or SA2015 helmet mandatory; shield permitted (goggles prohibited). See General Regulations 10:7.

PROTECTIVE CLOTHING

Full-length pants; short- or long-sleeved shirt; closed shoes; and socks. No shorts. No tank tops. No open-toe or open-heel shoes or sandals. Synthetic clothing not recommended. Jacket and pants meeting SFI Spec 3.2A/1 mandatory in AA/S through M/S, AA/SA through M/SA, FS/AA through FS/L, and in any vehicle running 11.49 or quicker. Jacket and pants meeting SFI Spec 3.2A/5 and SFI Spec 3.3/1 gloves mandatory in any vehicle running 9.99 or quicker. See General Regulations 10:10.

NECK COLLAR

Neck collar meeting SFI Spec 3.3 mandatory in any vehicle running 9.99 (*6.39) or quicker or exceeding 135 mph. A head and neck restraint device/system may be used in lieu of a neck collar. See General Regulations 10:8.



SECTION 12 SUPER STOCK

Requirements and specifications for all Super Stock categories are the same as those for Stock Cars - Section 10A - with the following exceptions:

This category for qualified cars in Super Stock, GT, GT Truck, Modified Stock, Modified Truck, Modified, and MX. Category races under the NHRA index/handicap system. Note: For more information on the Automatic Horsepower Factoring System, visit NHRARacer.com.

SECTION 12A SUPER STOCK

DESIGNATIONS

FSS/A, FSS/B, FSS/C, FSS/D, FSS/E, FSS/F, FSS/G, FSS/H, FSS/I, FSS/J, FSS/K, FSS/L, FSS/M, SS/AH, SS/A, SS/B, SS/C, SS/D, SS/E, SS/F, SS/G, SS/H, SS/I, SS/J, SS/K, SS/L, SS/M, SS/N, SS/O, and SS/P preceded by car number (manual transmission). SS/AA, SS/BA, SS/CA, SS/DA, SS/EA, SS/FA, SS/GA, SS/HA, SS/IA, SS/JA, SS/KA, SS/LA, SS/MA, SS/NA, SS/OA, and SS/PA preceded by car number (automatic transmission).

Reserved for foreign and domestic factory-produced automobiles and sports cars. Classified per NHRA performance rating as listed in the Official NHRA Stock Car Classification Guide. Only those cars listed in the guide are eligible. All cars must be factory production assembled, showroom available, and in the hands of the general public. Minimum of 50 factory-assembled units of an already accepted Stock model required.

CLASS WEIGHT BREAKS

(based on pounds per NHRA-factored horsepower)

FSS/A: 5.00 to 5.49	FSS/K: 10.00 to 10.99	G: 9.00 to 9.49
FSS/B: 5.50 to 5.99	FSS/L: 11.00 to 11.99	H: 9.50 to 9.99
FSS/C: 6.00 to 6.49	FSS/M: 12.00 or more	I: 10.00 to 10.99
FSS/D: 6.50 to 6.99	AH: 6.00	J: 11.00 to 11.99
FSS/E: 7.00 to 7.49	A: 6.00 to 6.49	K: 12.00 to 12.99
FSS/F: 7.50 to 7.99	B: 6.50 to 6.99	L: 13.00 to 13.99
FSS/G: 8.00 to 8.49	C: 7.00 to 7.49	M: 14.00 to 14.99
FSS/H: 8.50 to 8.99	D: 7.50 to 7.99	N: 15.00 to 15.99
FSS/I: 9.00 to 9.49	E: 8.00 to 8.49	O: 16.00 to 16.99
FSS/J: 9.50 to 9.99	F: 8.50 to 8.99	P: 17.00 or more



Call Today for your FREE Catalog

www.jerrybickel.com

(636) 356-4727

M O S C O W M I L L S
M I S S O U R I



PRODUCT
ENGINEERING

RACING FUEL SYSTEMS



**"BUY THE
BEST
FIRST!"**

**Backed
by our
2-year
warranty**



(763) 691-6391

product-engineering.net

DEALER INQUIRIES WELCOME

NHRA DISCOUNT ***Drag Racing Engine Parts!***



Be a *RACER* Rep!
and Receive **REAL DISCOUNTS** on **EVERY** Part

1000's of Race Engine Parts!
100's of Manufacturers Lines!



CALL FOR INFO!
800.233.0199

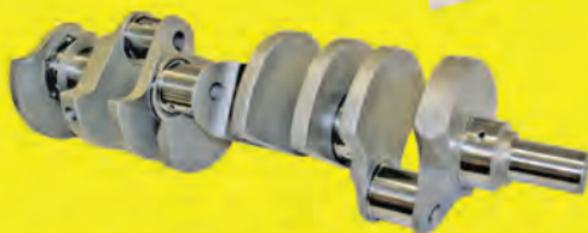

competitionproducts.com

CRAFTSMANSHIP • PRECISION
DURABILITY • STRENGTH

BBMX PLUS

BIG BLOCK MAX PLUS

- Available Early 2019
 - Big Power Requires a Stronger Rod and Oliver Racing Delivers with Our New BBMX-PLUS
 - 81% Increase in Area from Housing Bore to Bolt Spot Face Corner for Added Strength and Protection for High Horsepower Applications
 - 12% Increase in Cap Rib Thickness to Protect from Deformation Of Cap During Stroke To BDC
 - 4x Larger Radius @ Bolt Spot Face for Additional Strength and Big End Integrity
 - Wider Bolt Bore Spacing to Increase the Cap to Beam Joint Stiffness
 - Redesigned Side Features of Big End and Rod Face Geometry to Improve Strength While Minimizing Weight Gain
 - Available in All Popular Sizing for Chevy, Ford, MOPAR Applications in Rod Lengths:
6.385 | 6.535 | 6.635 | 6.700
6.800 | 7.000 | 7.100
Ford F6.700 | Ford F6.800
MOPAR MC7.100
- Custom Available
Upon Request*

OLIVER

RACING PARTS

SALES@OLIVERRACINGPARTS.COM

WWW.OLIVERRACINGPARTS.COM

231.237.4515



Made In America Since 1983

Class SS/AH restricted to 1968 Plymouth Barracuda and 1968 Dodge Dart with Hemi engine (automatic and/or manual). These vehicles restricted to this class only.

2008 and newer Chevrolet COPO, Dodge Drag Pak, and Ford Cobra Jet (automatic and manual) restricted to FSS/A through FSS/M.

Any competitor who causes an oil-down while participating at an NHRA Mello Yello event will be subject to fines and penalties as outlined in Section 2 - Oil-down Penalties.

REQUIREMENTS & SPECIFICATIONS

ENGINE: 1

AIR CLEANERS

Optional. If used, air cleaner must be OEM automotive or retain OEM configuration. Air-cleaner base may be cut or trimmed, but welding, bolting, riveting, epoxying, or any other form of fabrication prohibited. Ram tubes, velocity stacks, or other than stock-type base plates or ducting prohibited. Cooling holes prohibited in radiator side panels, etc. Factory air cleaners and/or scoops that fit through hood must be affixed to carburetor as per OEM only.

BLUEPRINTING

Permitted per NHRA Specifications available from NHRA Technical Services Department headquarters. Stock, factory OEM components (unless otherwise specified) must be retained and remain unaltered (i.e., connecting rods, pushrods, crankshaft, etc.).

CAMSHAFT

Any camshaft and valvetrain permitted.

CONNECTING RODS

Stock OEM or NHRA-accepted aftermarket rods permitted. Aftermarket rods may be up to 2 percent lighter than listed minimum weight and must be original length. Accepted replacements are published on NHRARacer.com. Grinding and polishing permitted on beams only. Shot-peening of connecting rods permitted. Length must be stock +/- .025-inch center to center. Otherwise lightening prohibited. The use of rod and crank spacer bearings permitted. Cylinder block housing bore size and rod bore housing size must maintain sizes as designated per NHRA's then-current approved rod listing.

CYLINDER HEADS

Must be correct casting number for year and horsepower claimed, per NHRA Technical Bulletins or NHRA-accepted. Cylinder-head casting must also be on NHRA runner volume list as published on NHRARacer.com. Porting, polishing, welding, epoxying, and acid-porting permitted. Grinding and polishing in combustion chamber permitted. Welding and/or applying epoxy in combustion chamber prohibited. Spark-plug hole must maintain the stock location, size, and angle as machined by the OEM; spark-plug adapters prohibited. Valve-guide centerlines must maintain the stock lateral and front-to-back location as machined by the OEM. Valves must maintain stock angle; valve-stem angle must remain stock, +/- 1 degree. Cylinder head must be able to hold combustion chamber, intake and exhaust runner volumes per NHRA Specifications. Any aftermarket steel valve permitted; must maintain stock head and stem size; titanium valves prohibited. (OEM sodium-filled valve may be replaced with titanium, provided weight is equal to or greater than original.) Valve diameter permitted to be +.005-inch or -.015-inch

from published NHRA Technical Bulletins. External modifications prohibited, intake side of head may not be cut into any part of valve-cover bolt holes (except for SS/AH). Valve-cover bolt holes must remain unaltered and in their original location. Welding or epoxying permitted on external portion of runners for repair only, maximum 2 runners per head. Heat riser passages may be blocked off from intake-manifold side of cylinder head or in exhaust port. The following are permitted: cylinder head studs, polylocks, jam nuts, screw-in or pinned studs. Any valve job accepted. Exhaust plate permitted between header and cylinder head, maximum 1/2-inch; may not protrude into exhaust port. Cylinder head may have all seats replaced.

ENGINE

Must be same year and make for car used, aftermarket NHRA-accepted cylinder blocks permitted. Equipment other than original factory-installed prohibited. Any special-equipment export kit (superchargers, dealer-installed options, etc.) automatically disqualifies car. Engine must remain in stock location — height, setback, etc. Cylinder bores must not exceed .080-inch over stock. Bores are measured at top of cylinder where ring wear is not evident. Crossbreeding parts prohibited. Normal balance job permitted. Otherwise lightening of component parts prohibited. All carburetors, manifolds, heads, etc. must be tightened to prevent any air or fuel leaks. Vacuum lines must be securely connected or blocked off. Stroke tolerance is +/- .015-inch. Stock OEM or NHRA-accepted aftermarket crankshaft mandatory. Aftermarket crank must retain OEM configuration (i.e., knife edging, narrowed/pendulum cut counterweights, etc. prohibited). Billet crankshafts prohibited, unless OEM equipped. Lightening of crankshaft other than normal balance job prohibited. The following are permitted: gun drilled rod and main journals, bull-nosed counterweights, any size rod and main journal, additional oil passage holes for rod and main journals. Cylinder blocks may be sleeved. Aftermarket SFI Spec 18.1 harmonic balancer mandatory. Timing-belt covers optional. See General Regulations 1:2.

SUPERSEDED AND/OR REPLACEMENT PARTS

Superseded parts are restricted to cylinder heads, intake manifold, crankshaft, cylinder block, and transmissions only when manufacturer lists such parts in its published parts book and notifies NHRA of said change and change is accepted by NHRA.

EXHAUST SYSTEM

“Pan Evac” system attached to exhaust permitted. Mufflers and/or maximum decibel levels may be enforced at certain facilities, according to any local ordinances that may be in effect. Contact individual tracks for more information. See General Regulations 1:3.

FAN, GENERATOR, WATER PUMP

Generator or alternator may be removed. Aftermarket pulleys permitted. Electrically driven fans and water pumps permitted. Water pump must bolt on with no modifications to block. Use of “smog pump” or air pump for crankcase evacuation prohibited.

FUEL

NHRA-accepted racing gasoline only. Propylene oxide and/or nitrous oxide prohibited. See General Regulations 1:6.

FUEL SYSTEM

Any mechanical fuel pump and/or maximum two electric fuel pumps permitted. May be mounted in trunk. Electric pump must shut off with car’s ignition switch. Fuel lines may be changed to any size metallic line with inline fuel filters and pressure regulators permitted; a maximum 12 inches of rubber lines for vibration connections are permitted. One cool can permitted. See General Regulations 1:5.

GASKETS

Any replacement or aftermarket gasket permitted. If thinner-than-stock head gaskets are used, thickness loss must be made up with additional deck clearance. Difference in deck clearance can also be made up using thicker-than-stock gaskets. Carburetor heat-insulator-type gaskets permitted.

GAS TANKS

Original stock-type fuel tank permitted; must be mounted in stock location. Tank may be notched or sectioned for suspension clearance or to fit narrowed rear-frame unit. If filler neck is relocated into trunk, tank must have pressure cap and be vented to outside of body. Trunk must be completely isolated from driver compartment with firewall, minimum .024-inch steel or .032-inch aluminum. Accessory tank(s) prohibited. Fuel cell permitted, minimum 3-gallon, maximum 16-gallon capacity; may be mounted in trunk. Cool cans, fuel blocks permitted. Only one fuel cell or tank permitted. See General Regulations 1:5.

INTAKE MANIFOLD

Any intake manifold permitted provided unit is of same configuration as original for carburetor used and will fit under original factory-produced, installed hood. Multiple carburetion applications must retain original relationship of carbs; e.g., inline must remain inline, cross ram must remain cross ram. On cross rams, OEM relationship of which carb is in front or back may be reversed.

INTERCOOLER

Intercooler tanks must be located in the engine compartment.

OIL PAN

May be rebuilt to add to capacity of stock unit. Dry-sump systems prohibited. Aftermarket oil pans permitted. If crossmember is altered for larger oil-pan installation, all material and strength must be replaced by boxing or installing removable or permanent material.

OIL PUMP

Stock, OEM, or OEM aftermarket replacement oil pump permitted. Oil pump location, oil pump drive, and complete oiling system must remain as originally produced, except for additional internal plumbing (i.e., rocker shaft, etc.), which is permitted. Accumulator permitted. Additional external plumbing (except for accumulator, remote oil filter, and line(s) from the oil pan to oil pump) prohibited. Dry-sump system prohibited.

PISTONS

Replacement pistons permitted, provided they do not increase stock compression ratio and retain overall design pattern as specified by automobile manufacturer. Dish pistons must retain half of original depth, and original diameter and configuration. Dish pistons must hold no less than original volume, per NHRA Blueprint Specs. Domed pistons may displace no more volume than original, according to NHRA Blueprint Specs, regardless of dome height. Valve clearance reliefs permitted. Gas porting of pistons permitted.

RADIATOR

Full-size stock radiator mandatory for body used. Aluminum radiators permitted; must retain stock dimensions and appearance. Cutting, denting, or elimination of any body, fender, radiator, or grille panels prohibited.

DRIVETRAIN: 2**CLUTCH, FLYWHEEL, FLYWHEEL SHIELD**

Clutch and flywheel meeting SFI Spec 1.1 or 1.2 (2-disc maximum) mandatory. Steel flywheel shield meeting SFI Spec

6.1 mandatory on all V-8 cars with a clutch. Flywheel shield cannot be modified for clutch adjustment and/or cooling holes. See General Regulations 2:3, 2:5, 2:6, 2:10.

DRIVELINE

Steel or aluminum driveshaft permitted; carbon fiber prohibited. See General Regulations 2:4.

REAR END

Any OEM automotive type permitted. Entirely custom fabricated rear-end housing prohibited. Aftermarket aluminum center sections or pinion supports permitted. May be narrowed for wide tires. See TIRES. Truck rear ends prohibited unless originally factory installed. Spool permitted with aftermarket axles. Two-speed or quick-change rear ends prohibited. Cars that weigh more than 2,000 pounds with independent rear suspension without upper and lower (both) control arms must replace swing axle differential with conventional differential housing assembly. (Example: 1963-1982 Corvette.) Cars with independent rear suspension using upper and lower (both) control arms may retain swing axle assembly regardless of weight. Must have 360-degree, minimum 1-inch-wide by 1/4-inch-thick axle retention loop on each axle. Alterations to crossmembers permitted when independent rear suspension rear end is replaced. See General Regulations 2:11.

TRANSMISSION, AUTOMATIC

Any model transmission, same make as car, with a maximum of three forward speeds (unless OEM equipped with more than three forward speeds). O.D. gear not required, reverse permitted. Transmission case must be OEM or aftermarket OEM replica from a standard automotive application as found in the Official NHRA Stock Car Classification Guide. Aftermarket case must meet SFI Spec 4.1 and 30.1. NHRA-accepted adapter plates permitted. Modifications to shifting patterns are permitted, provided full shift pattern is retained. Full shift pattern must include park and reverse. Lockup converter permitted if OEM equipped with lockup converter and OEM transmission is used. Otherwise, lockup converters prohibited. Deepened stock or aftermarket transmission oil pans permitted. Drilling of transmission case or rear of engine block to adapt incompatible units prohibited. Functional neutral safety switch mandatory. Aftermarket replacement transmission case, OEM replica and accepted by NHRA, permitted. Transmission brake permitted, electric transbrake release system only. Transbrake buttons must be NHRA-accepted. Devices must be mechanical-spring actuated and not exceed 3 inches in length from base of (button) switch to top of plunger. Adjustability is permitted and may be made by a thread stop or stop rings. Modifying the switch by the addition of hydraulics, pneumatics, electric, or other means is prohibited (see NHRARacer.com for accepted list). Rpm-activated pneumatic, electric shifters permitted. See General Regulations 8:2 for correct wiring procedure. See General Regulations 2:12, 2:14.

TRANSMISSION, MANUAL

OEM or NHRA-accepted aftermarket transmissions having same number of forward speeds (O.D. gear not required) as original, and reverse, may be used. All gear changes must result from direct action by the driver. Pneumatic, hydraulic, electric, etc. shifters prohibited. Floor shift-conversion kits permitted. Clutchless transmissions permitted. If any engine/manual transmission combination is listed in the class blueprint specification as being available with only a three-speed manual transmission, it may be replaced with any four-speed manual transmission. See General Regulations 2:12.

TRANSMISSION SHIELD, AUTOMATIC

Cars in SS/AH through SS/MA, FSS/A through FSS/M, and any car running quicker than 10.99 must be equipped with a transmission shield meeting SFI Spec 4.1. Cars in SS/AH through SS/JA and FSS/A through FSS/M, SFI 29.1 automatic transmission flexplate and SFI 30.1 flexplate shield mandatory. Aftermarket automatic transmission bellhousing permitted; must be labeled as meeting SFI Spec 30.1 for automatic transmission flexplate shields and must be NHRA-accepted. Aftermarket OEM-style replica case, NHRA-accepted, permitted. See General Regulations 2:14.

BRAKES & SUSPENSION: 3**BRAKES**

Must be equipped with stock production four-wheel hydraulic brake system, or aftermarket disc brakes meeting the following criteria:

1. Minimum effective piston area per wheel: 3 1/2 square inches.
2. Minimum disc (rotor) diameter 10 1/4 inches x 5/16-inch thick.
3. Must install dual reservoir master cylinder with any modified brake system, splitting front and rear into separate systems.
4. Dual calipers on rear wheels permitted, maximum one hydraulic brake line to dual rear brake system (no wires).
5. Rear-wheel line-loc prohibited; front-wheel line-loc permitted. Parking brake optional.
6. Carbon-fiber and titanium brake rotors prohibited. See General Regulations 3:1.

Four-wheel or rear-wheel line-loc prohibited. All line-locs must be spring-loaded or self-returning to normal operating mode.

SHOCKS

No pneumatic or electric shocks permitted unless such items were OEM equipment. Reservoirs permitted.

SUSPENSION, FRONT

Must retain complete stock front-suspension system as produced by manufacturer for body used. Lift kits/travel limiters permitted. Sway bar optional. Aftermarket tie rods with heim joints permitted. Lower control arm may be machined for larger shock diameter and mount. Strut rods with heim joints or spherical bearings permitted. Electric shocks prohibited. See General Regulations 3:4.

SUSPENSION, REAR

Stock rear suspension may be changed as follows: Lateral movement inboard permitted when rear frame and/or suspension is moved in for tire clearance. Mounting points may be moved in on axle housing and frame as required. In addition to stock suspension, a pivot below rear axle housing is permitted. Axle housing may rotate in spring mount; side movement of housing limited to 1/4-inch. Spring mounts may slide on leaf-spring-equipped cars no more than 1/2-inch forward or rearward. See illustration in General Regulations 3:4 for acceptable pivot mount for rear suspension. Leaves may be added or removed. Rear leaves may be aftermarket fiberglass type. Rear leaf springs need not be same length as original. Coil springs may be replaced with similar-configuration units; rear trailing arms may be replaced or removed when using four-link or ladder-bar suspension. Removal of original springs permitted. Coilover shocks permitted in rear suspension. Shocks may be relocated; minimum down travel on shock is 1 inch. Rear trailing arms may be replaced with OEM-type aftermarket units, round tubing permitted, 1-inch-minimum diameter. Bushing must be in trailing arms that allow suspension movement but keep parts from being noticeably loose. See General Regulations 3:4.

WHEELIE BARS

Permitted. Wheels must be non-metallic. May not be attached to rear bumper or bumper braces. May be 48 inches in length or to rear bumper, whichever is longer. Length is checked from center-line of rear axle to center of wheelie-bar wheel. See General Regulations 3:6.

FRAME: 4**BALLAST**

Weight box permitted. Only 100 pounds removable ballast permitted, including box (two-box maximum with 50 pounds each). Must be attached to frame or crossmember with minimum of two 1/2-inch bolts. May not be attached to roll bar or cage. Additional ballast must be permanently attached to frame or crossmember; i.e., bolted with at least two 1/2-inch bolts per 100 pounds, with nut welded to bolt. See WEIGHT. See General Regulations 4:2.

BUMPERS

Complete stock bumpers, guards, and braces (front and rear) mandatory, consistent with make, model, year claimed. Energy-absorbing apparatus may be removed.

Rear bumper cover or valance only (i.e., not the bumper) may be notched or slotted for clearance around wheelie bars. Opening maximum is to allow for wheelie-bar movement only. Removal of rear bumper cover or trimming rear bumper cover the full width of wheelie bar prohibited.

FRAME

Frame or subfloor must be stock for body used. Subframes on unibody cars may be joined under car. Maximum-size material to be used: 2 inches x 3 inches x 1/8-inch or 1 5/8-inches by .118-inch (mild steel) or .083-inch (chromoly) round tubing. If connector protrudes through floor, floor must be completely welded to connector. Rear subframes may be moderately moved in or "C'd" for tire clearance (see TIRES). Rear subframe may be constructed of 2-inch x 3-inch rectangular material with .083-inch wall thickness or 1 5/8 O.D. x .083-inch wall chromoly (.118-inch wall mild steel) round tubing, and must be installed at original height location. Bottom of framerail may not be higher than location of original floor. Crossmembers may be added for traction-bar and shock-absorber mounts. If new frame material passes through floor, floor must be welded to frame, leaving no holes. See FLOOR in this section.

GROUND CLEARANCE

Minimum 3 inches from front of car to 12 inches behind centerline of front axle, 2 inches for remainder of car, except oil pan and exhaust headers.

MOTOR MOUNTS

May be replaced with steel units designed to eliminate rubber section of stock mounts. Engine must be in stock location — height, setback, etc. Motor plates and mid mount permitted.

PARACHUTE

Mandatory on any car that runs 150 mph or faster. See General Regulations 4:8.

ROLL BAR

Mandatory in SS/J through SS/P, SS/JA through SS/PA, and in any car running 11.49 or quicker. Roll cage mandatory in any car running 9.99 or quicker, permitted in slower vehicles. See General Regulations 4:10.

ROLL CAGE

Mandatory in SS/A through SS/I, SS/AH through SS/IA, FSS/A

through FSS/M, and any car running 9.99 or quicker. Roll cage meeting SFI 25.4 or 25.5 is mandatory for all Super Stock cars running 8.49 or quicker. See General Regulations 4:4, 4:11, 10:6.

ROLL-CAGE PADDING

Roll-cage padding meeting SFI Spec 45.1 mandatory on any vehicle running 9.99 and quicker. Padding must be used anywhere driver's helmet may come in contact with roll-cage components. See General Regulations 4:11, 10:6.

WEIGHT

All cars will be permitted to run on the class minimum weight, but may be no heavier than the minimum for the next heavier class. Car can move up (lighter) one class or down (heavier) one class. If weight is added, must be properly attached; see BALLAST. Shipping weight is calculated by multiplying the power to weight factor (as found in the Official NHRA Stock Car Classification Guide) by advertised horsepower. In cases where NHRA has placed a performance rating on the engine, use the factored horsepower. Class and classification weight are determined without driver. Once classification weight is calculated, 170 pounds is added for driver to arrive at total weight. All cars are weighed with driver.

WHEELBASE

Must retain stock wheelbase, +/- 3/4-inch, for car body used per manufacturer's nominal specifications. Maximum variation from left to right: 1 inch. Any alteration to wheelbase, front and/or rear overhang, or relocation of wheel and/or axle location prohibited. See General Regulations 4:12.

TIRES & WHEELS: 5

TIRES

Rear tire (new) must not exceed 14 1/2 inches wide by 33 inches diameter; may not exceed 15 1/2 inches wide regardless of wear. Tire tread may not be outside fender. Maximum clearance between sidewall and body 3 inches. See General Regulations 5:1.

WHEELS

Aftermarket racing wheels permitted. Automotive wire wheels or motorcycle wheels prohibited. Any wheel/tire combination may be used that does not require alterations to wheelwells except as described under FENDERS. Minimum wheel diameter: 14 inches, unless factory equipped with smaller wheels. The front wheel must be mounted using an OEM configuration. Spindle-mount designs prohibited. See General Regulations 5:2.

INTERIOR: 6

STEERING WHEELS

Removable steering wheel permitted, provided stock column appearance is retained. Lengthening of steering column prohibited. Must maintain OEM length. See General Regulations 3:3.

UPHOLSTERY

Must have full factory-type upholstery, including factory-type floor mats or carpet, door panels, and headliner, and front and rear seats. Interior gutting prohibited. Driver's seat tracks may be bolted down. Sun visors optional. Rear seat may be removed when roll bar or roll cage is installed; area must be carpeted or upholstered equivalent to factory specifications (no bare paneling). Full-size aftermarket or corporate OEM front seats permitted; must be upholstered and supported. If a full-sized corporate OEM driver's seat is used, the passenger seat must be identical in appearance to the driver's seat. If a full-sized

aftermarket driver's seat is used, the passenger seat must be full-sized and identical in appearance to the driver's seat being used or must be a full-sized corporate OEM passenger seat. See General Regulations 6:2.

WINDOW NET

A ribbon-type or SFI 27.1 mesh-type window net is mandatory in classes requiring a roll cage. See General Regulations 6:3.

BODY: 7

BODY

Alterations or customizing prohibited; extent of customizing is limited to paint only. Convertible-top cars must run with top up. Sedan delivery, Ranchero, El Camino, etc. (if found properly classified in the Classification Guide) are eligible only if all class requirements are met. Raising and/or lowering front or rear of cars prohibited. Cars must retain level attitude at standstill, except those that have a forward rake (a permitted modification). Bottom of rocker panel cannot be higher than centerline of rear axle. Body mount insulators may be replaced with solid mounts of same size. Aluminum or other lightweight material may not be used to replace heavier items on car.

FENDER SPLASH PANS

Must be retained; may be trimmed to allow 2-inch clearance around headers. Alterations to shock or spring towers prohibited. See General Regulations 7:3.

FIREWALL

Alterations prohibited. Firewall coverings prohibited. Where heater/air conditioning units have been removed, area must be covered with minimum .024-inch steel or .032-inch aluminum, including rear hood seal/flange, as on GM A-body. See General Regulations 7:4.

FLOOR

Removable floor section for transmission/shifter installation permitted; restricted to 6 square feet (2 x 3 feet, 1 x 6 feet, etc.) of steel material identical to area removed. Stock floor may be sectioned where rear frameroils have been narrowed. Area between frameroils must be stock floor, in original location. Area between new rear frameroils (from four-link crossmember rearward only) and body may be replaced with material equal to or heavier than original; must be in original location. All other floor material must be stock and in original location. See General Regulations 7:5.

GRILLE

Must be full production for make, model, and year claimed. Covering in front or behind grille prohibited.

HOOD

Full stock hood including latches, hinges, springs, brackets, and braces as originally produced must be retained. Hood openings and/or hood scoops other than original equipment prohibited. OEM hood openings must retain all flappers, grilles, hardware, etc. as originally produced.

STREET EQUIPMENT

The following are not required and may be removed: emission controls; windshield-wiper blades, arms, and motor; heater/air conditioning and associated plumbing (controls must remain in dash, see INSTRUMENTS). Turn signals, etc. need not be operative. One working headlight and one working taillight mandatory.

WHEELWELLS, REAR

Internal modifications only. Flaring or spreading of external

fender lines prohibited. Any material used to add to width of inner wheelwells must be of same material and thickness as original; aluminum or carbon fiber prohibited.

ELECTRICAL: 8

BATTERIES

Trunk installation permitted; two batteries permitted. Maximum weight, wet, fully charged, including battery box: 100 pounds. See General Regulations 8:1.

DELAY BOXES/DEVICES

Prohibited. See General Regulations 8:2.

DISTRIBUTOR

Any battery-powered ignition system permitted. Distributorless ignition must retain OEM number of coils. See General Regulations 8:3.

INSTRUMENTS

Full stock dashboard, including instruments, fresh-air ducts, and controls, must be retained. Heaters/air conditioners may be removed; controls must remain in dashboard. Tachometer, pressure gauges, etc. optional. See General Regulations 8:8.

MASTER CUTOFF

Mandatory on all cars with battery in the trunk. See General Regulations 8:4.

STARTERS

Aftermarket starters, in stock location, permitted. See General Regulations 8:5.

SUPPORT GROUP: 9

COMPUTER/DATA RECORDERS

Original OEM or OEM replacement computer permitted. All others prohibited. Data recorder permitted. See General Regulations 9:1, 9:2.

TOW VEHICLES

Prohibited.

WARM-UPS

See General Regulations 9:5, 9:14.

DRIVER: 10

CREDENTIALS

Valid NHRA competition license mandatory in SS/A through SS/I, SS/AH through SS/IA, and FSS/A through FSS/M. Valid NHRA competition license mandatory for cars running 9.99 (*6.39) or quicker. Valid state- or government-issued driver's license beyond a learner's-permit level mandatory for cars running 10.00 (*6.40) or slower. See General Regulations 10:4.

DRIVER

Must be in stock location with no part of the driver's head behind the "B" post.

DRIVER RESTRAINT SYSTEM

Driver restraint system meeting SFI Spec 16.1 or 16.5 mandatory. Restraint system must be updated at two-year intervals from date of manufacture. See General Regulations 10:5.

HELMET

For all 10.00 and slower cars, either an open-face or a full-face Snell M2010, M2015, SA2010, or SA2015 helmet mandatory; shield permitted (goggles prohibited).

For all 9.99 and quicker cars, a full-face Snell M2010, M2015,

SA2010, or SA2015 helmet mandatory; shield permitted (goggles prohibited). See General Regulations 10:7.

NECK COLLAR

Neck collar meeting SFI Spec 3.3 mandatory in all cars running 9.99 (*6.39) or quicker or cars exceeding 135 mph. A head and neck restraint device/system may be used in lieu of a neck collar. See General Regulations 10:8.

PROTECTIVE CLOTHING

All drivers are required to wear full-length pants; short- or long-sleeved shirt; closed shoes; and socks. No shorts. No tank tops. No open-toe or open-heel shoes or sandals. Synthetic clothing not recommended. SFI Spec 3.3/1 gloves mandatory in any vehicle running 9.99 or quicker. See General Regulations 10:10.

Jacket and pants meeting SFI Spec 3.2A/5 mandatory in SS/A through SS/I, SS/AH through SS/IA, and FSS/A through FSS/M or any vehicle running 9.99 or quicker. Jacket and pants meeting SFI Spec 3.2A/1 mandatory in SS/J through SS/P and SS/JA through SS/PA or any vehicle running 10.00 to 11.49.

SECTION 12B SUPER STOCK/GT

Requirements and specifications for GT classes are the same as those for Super Stock classes - Section 11A - with the following exceptions:

DESIGNATIONS

FGT/A, FGT/B, FGT/C, FGT/D, FGT/E, FGT/F, FGT/G, FGT/H, FGT/I, FGT/J, GT/A, GT/B, GT/C, GT/D, GT/E, GT/F, GT/G, GT/H, GT/I, GT/J, GT/K, GT/L, and GT/M, preceded by car number (manual transmission). GT/AA, GT/BA, GT/CA, GT/DA, GT/EA, GT/FA, GT/GA, GT/HA, GT/IA, GT/JA, GT/KA, GT/LA, and GT/MA, preceded by car number (automatic transmission).

DESIGNATIONS (FOR 2019 SEASON)

FGT/A, FGT/B, FGT/C, FGT/D, FGT/E, FGT/F, FGT/G, FGT/H, FGT/I, FGT/J, FGT/K, FGT/L, FGT/M, FGT/N, GT/A, GT/B, GT/C, GT/D, GT/E, GT/F, GT/G, GT/H, GT/I, GT/J, GT/K, GT/L, GT/M, GT/N, GT/O, GT/P, and GT/Q, preceded by car number (manual transmission). GT/AA, GT/BA, GT/CA, GT/DA, GT/EA, GT/FA, GT/GA, GT/HA, GT/IA, GT/JA, GT/KA, GT/LA, GT/MA, GT/NA, GT/OA, GT/PA, and GT/QA, preceded by car number (automatic transmission).

Reserved for foreign and domestic factory-production two-door coupes, two-door sedans, sports cars, convertibles, or station wagons with any production V-8 engine of the same make. Year of engine optional. Only those engines and/or bodies listed in the Official NHRA Stock Car Classification Guide are eligible for competition. Also see WEIGHT. Cars will be classified using the shipping weight of the body divided by the horsepower or performance rating of the engine used. Minimum weight with driver: 2,670 pounds.

Front-wheel-drive conversions permitted. Minimum weight with driver: 2,670 pounds. Only engines and/or bodies listed in the Official NHRA Stock Car Classification Guide are eligible for competition.

CLASS WEIGHT BREAKS

(based on pounds per NHRA-factored horsepower)

FGT/A: 6.00 to 6.49	FGT/L: 11.50 to 11.99	I: 10:00 to 10:49
FGT/B: 6.50 to 6.99	FGT/M: 12.00 to 12.49	J: 10:50 to 10.99
FGT/C: 7.00 to 7.49	FGT/N: 12.50 or more	K: 11.00 to 11.49
FGT/D: 7.50 to 7.99	A: 6.00 to 6.49	L: 11.50 to 11.99
FGT/E: 8.00 to 8.49	B: 6.50 to 6.99	M: 12.00 to 12.49
FGT/F: 8.50 to 8.99	C: 7.00 to 7.49	N: 12.50 to 12.99
FGT/G: 9.00 to 9.49	D: 7.50 to 7.99	O: 13.00 to 13.49
FGT/H: 9.50 to 9.99	E: 8.00 to 8.49	P: 13.50 to 13.99
FGT/I: 10.00 to 10.49	F: 8.50 to 8.99	Q: 14.00 or more
FGT/J: 10.50 to 10.99	G: 9.00 to 9.49	
FGT/K: 11.00 to 11.49	H: 9.50 to 9.99	

2008 and newer Chevrolet COPO, Dodge Drag Pak, and Ford Cobra Jet or their engine combinations (automatic and manual) restricted to FGT/A through FGT/N.

REQUIREMENTS & SPECIFICATIONS**ENGINE: 1****ENGINE**

V-8 only; must be same make as body. Year optional. Engine must be listed in both the NHRA Stock Car Classification Guide and NHRA Blueprint Bulletins. Corporate engines permitted. Truck engines prohibited. Underhood modifications for engine installation prohibited (i.e., firewall, shock towers, frame, excessive cutting of cross member for clearance, etc.). All other rules as outlined under Super Stock ENGINE will apply. See General Regulations 1:2.

DRIVETRAIN: 2**TRANSMISSION SHIELD, AUTOMATIC**

Cars in GT/AA through GT/LA, FGT/A through FGT/J, and any car running quicker than 10.99 must be equipped with a transmission shield meeting SFI Spec 4.1. Cars in GT/AA through GT/GA and FGT/A through FGT/J, SFI 29.1 automatic transmission flexplate and SFI 30.1 flexplate shield mandatory.

TRANSMISSION SHIELD, AUTOMATIC (FOR 2019 SEASON)

Cars in GT/AA through GT/PA, FGT/A through FGT/N, and any car running quicker than 10.99 must be equipped with a transmission shield meeting SFI Spec 4.1. Cars in GT/AA through GT/KA and FGT/A through FGT/N, SFI 29.1 automatic transmission flexplate and SFI 30.1 flexplate shield mandatory.

BRAKES & SUSPENSION: 3**BRAKES**

Master cylinder must be mounted to the inside or outside of firewall. All other locations prohibited.

STEERING, FWD CONVERSIONS

May be relocated. Fabricated crossmember may be installed. Stock-type steering and OEM lower A-arms mandatory. See General Regulations 3:3.

SUSPENSION, FRONT

For FWD conversions, aftermarket or OEM front suspension of a stock configuration is required. Replacement control arms permitted. A full-tube chassis prohibited. The chassis must be built around existing OEM body and must retain the as-built OEM upper framersails in front of firewall. The mounting point of replacement lower control arms may be non-OEM. The use of adjustable heim (or heim-type) joints permitted.

Any OEM or aftermarket shock absorber of a stock type permitted. Any OEM or aftermarket bushings are permitted. All other components (i.e., upper A-arms, springs, rods, fasteners, etc.) must be steel unless material similar to the original/stock components is used.

The struts must mount to the as-built upper OEM location. The strut lower tower may be modified (i.e., existing holes slotted or enlarged), but may not be reconfigured (i.e., welded shut). The strut mount may utilize an adapter or plate on the underside of the strut tower to facilitate camber/caster adjustment. Final strut installation must be in a manner such that removing the three bolts on top of the strut tower allows strut assembly removal.

Lift kits/travel limiters permitted. Sway bar optional.

RWD must retain complete stock front-suspension system or utilize an NHRA-accepted front suspension. Lower control arm may be machined for larger shock diameter and mount. See General Regulations 3:4.

FRAME: 4

BUMPER

The front and rear bumpers must be attached to the chassis using the OEM impact bars. The bracing of the rear bumper can be reinforced by using aftermarket tubing and be attached to the rear frame section and body panels to retain exterior factory appearance. Inside front and rear bumpers must retain factory appearance. Covering of cavities prohibited.

Rear bumper cover only (i.e., not the bumper) may be notched or slotted for clearance around wheelie bars. Opening maximum is to allow for wheelie-bar movement only. Removal of rear bumper cover or trimming rear bumper cover the full width of wheelie bar prohibited.

FRAME, FWD CONVERSIONS

The forward stock frame/support assembly must be retained. It may be modified or trimmed for engine, exhaust header, etc. clearance. Aftermarket/fabricated forward-clip frame components of 2-inch x 3-inch x .083-inch wall steel or 2 1/2-inch O.D. x .120-wall steel maximum may be added to reinforce the as-built stock frame/support assembly. As-built OEM crossmembers may be relocated and/or trimmed for oil pan and/or engine clearance. The OEM engine cradle/lower (or inner) framrails may be retained, modified, or replaced.

ROLL BAR

Mandatory in GT/H through GT/M, GT/HA through GT/MA, and in any vehicle running 11.49 or quicker, permitted in slower vehicles. Roll cage mandatory in any car running 9.99 or quicker, permitted in slower vehicles. See General Regulations 4:10.

ROLL CAGE

Mandatory in GT/A through GT/G, GT/AA through GT/GA, FGT/A through FGT/J, and in any vehicle running 9.99 or quicker. Roll cage meeting SFI 25.4 or 25.5 is mandatory for all Super Stock cars running 8.49 or quicker. See General Regulations 4:4, 4:11, 10:6.

ROLL CAGE (FOR 2019 SEASON)

Mandatory in GT/A through GT/K, GT/AA through GT/KA, FGT/A through FGT/N, and in any vehicle running 9.99 or quicker. Roll cage meeting SFI 25.4 or 25.5 is mandatory for all Super Stock cars running 8.49 or quicker. See General Regulations 4:4, 4:11, 10:6.

WEIGHT

Shipping weight of vehicle may be adjusted a maximum of 250 pounds to fit car in class. Car can move up or down in classes. If weight is added, must be properly attached; see General Regulations, 4:2. Shipping weight will be determined by using the power to weight factor of the vehicle with the heaviest gasoline engine and appropriate transmission, and multiplying the factor times the horsepower or performance rating. The proper class weight will then be determined by dividing this figure by the horsepower or performance rating of the engine used. Class is determined without driver weight. Once classification weight is calculated, 170 pounds will be added for driver to arrive at minimum weight.

INTERIOR: 6**DASH**

Dash must remain as-built OEM, but may be removable. Removable dash must be securely attached, and any non-factory fasteners must be concealed to retain factory appearance. Aftermarket or non-OEM dash prohibited.

UPHOLSTERY

Must have full factory-type upholstery, including factory-type carpet, door panels, and headliner. Interior gutting prohibited. Replacement door panels and headliner permitted, but must be fully upholstered to retain OEM appearance. Carpet must cover entire floor and any floor chassis/frame components in the floor area within the driver's compartment.

BODY: 7**FENDER**

Inner fender panels may be relocated/trimmed on front-wheel drive unibody vehicles from the front side of strut tower forward. Area may be enlarged for tire clearance, but must retain a finished, OEM appearance.

FIREWALL

The lower portion of the OEM firewall may be replaced with steel of equal or greater thickness than OEM. Chevy Cavaliers, Pontiac Grand Ams and Sunfires, and Ford Escorts may have firewall replaced or relocated, provided the measurement from the rear of the radiator core support to the firewall is 34 inches maximum. For Chevy Cobalt the radiator core support to the firewall is 33 inches maximum. For all other vehicles, firewall must be in the original location. A complete one-piece steel firewall that resembles OEM must be installed, welded in place, and sealed from the driver compartment. The firewall must extend to and attach to the floor. The firewall and mid-plate must be two separate pieces. All motor plates, mid-plates, etc. must be separate from and may not be attached to the firewall.

FLOOR

Headers must fit under stock floor location. The stock framersails from the firewall to the radiator support must retain stock attachment configuration, stock location, and stock dimensions. Frame may be notched for header clearance.

For FWD conversion cars, a driveshaft tunnel must be fabricated of same-as-OEM material minimum and must be fully welded to the as-built OEM floor. See General Regulations 7:5.

ELECTRICAL: 8**DISTRIBUTOR**

Any battery-powered ignition system permitted. See General Regulations 8:3.

DRIVER: 10**CREDENTIALS**

Valid NHRA competition license mandatory in GT/A through GT/G, GT/AA through GT/GA, and FGT/A through FGT/J or for any car running 9.99 or quicker. See General Regulations 10:4.

PROTECTIVE CLOTHING

Jacket and pants meeting SFI Spec 3.2A/5 mandatory in GT/A through GT/G, GT/AA through GT/GA, and FGT/A through FGT/J or any vehicle running 9.99 or quicker. Jacket and pants meeting SFI Spec 3.2A/1 mandatory in GT/H through GT/M and GT/HA through GT/MA or any vehicle running 10.00 to 11.49. SFI Spec 3.3/1 gloves mandatory in any vehicle running 9.99 or quicker. See General Regulations 10:10.

PROTECTIVE CLOTHING (FOR 2019 SEASON)

Jacket and pants meeting SFI Spec 3.2A/5 mandatory in GT/A through GT/K, GT/AA through GT/KA, and FGT/A through FGT/N or any vehicle running 9.99 or quicker. Jacket and pants meeting SFI Spec 3.2A/1 mandatory in GT/L through GT/Q and GT/LA through GT/QA or any vehicle running 10.00 to 11.49. SFI Spec 3.3/1 gloves mandatory in any vehicle running 9.99 or quicker. See General Regulations 10:10.

SECTION 12C

GT/TRUCK

Requirements and specifications for GT Truck classes are the same as those for GT car classes - Section 11B - with the following exceptions:

DESIGNATIONS

GT/TA, GT/TB, GT/TC, and GT/TD preceded by truck number.

Reserved for 1980 and newer pickup trucks, 1/2-ton maximum. Year of engine optional. Only those engines and/or bodies listed in the Official NHRA Stock Car Classification Guide are eligible for competition. Trucks will be classified using the shipping weight of the body divided by the horsepower or performance rating of the engine used. If the claimed engine has both a Super Stock and a GT rating, the GT rating shall apply.

CLASS WEIGHT BREAKS

(based on pounds per NHRA-factored horsepower)

TA: 9.50 to 10.49 TB: 10.50 to 11.49 TC: 11.50 to 12.49
TD: 12.50 or more

REQUIREMENTS & SPECIFICATIONS

DRIVETRAIN: 2**TRANSMISSION SHIELD, AUTOMATIC**

Trucks in GT/TA through GT/TD must be equipped with a transmission shield meeting SFI Spec 4.1. Trucks in GT/TA and GT/TB, SFI 29.1 automatic transmission flexplate and SFI 30.1 flexplate shield mandatory. See General Regulations 2:14.

FRAME: 4**ROLL CAGE**

Mandatory. Roll cage meeting SFI 25.4 or 25.5 is mandatory

for all Super Stock trucks running 8.49 or quicker. See General Regulations 4:4, 4:11, 10:6.

WEIGHT

Shipping weight of vehicle may be adjusted a maximum of 250 pounds to fit truck in class, provided shipping weight does not drop below 2,500 pounds. Truck can move up or down in classes. If weight is added, must be properly attached; see General Regulations 4:2. Shipping weight will be determined by using the power to weight factor of the 1990-2008 vehicle and multiplying the factor by the horsepower or performance rating. The proper class weight will then be determined by dividing this figure by the horsepower or performance rating of the engine used. Class is determined without driver weight. Once classification weight is calculated, 170 pounds will be added for driver to arrive at minimum weight.

Trucks with fully automatic transmissions with converter may remove up to 5 percent or 250 pounds (whichever is less) from regular class weight; may be under minimum posted weight. For trucks weighed with driver, minimum weight includes driver.

DRIVER: 10**CREDENTIALS**

Valid NHRA competition license mandatory in TA or any vehicle running 9.99 or quicker. See General Regulations 10:4.

PROTECTIVE CLOTHING

Jacket and pants meeting SFI Spec 3.2A/5 mandatory in TA, or any vehicle running 9.99 and quicker or 135 mph or faster. Jacket and pants meeting SFI Spec 3.2A/1 mandatory in TB, TC, and TD. SFI Spec 3.3/1 gloves mandatory in any vehicle running 9.99 or quicker. See General Regulations 10:10.

SECTION 12D MODIFIED STOCK

Requirements and specifications for Modified Stock classes are the same as those for Super Stock classes - Section 11A - with the following exceptions:

DESIGNATIONS

SS/AS, SS/BS, SS/CS, SS/DS, SS/ES, SS/FS, and SS/GS preceded by car number.

Reserved for 1967 or later NHRA-accepted, factory-production cars. Body, engine, drivetrain, chassis, etc. may not be altered or relocated except as outlined in Requirements & Specifications. Front-wheel-drive conversions permitted. Classes of competition within Modified Stock are for non-supercharged cars. Class determined by total car weight (including driver) divided by total engine displacement (cubic inches).

CLASSES

- AS - 8.50 to 9.49 or more pounds per cubic inch. Wedge, canted-valve or Hemi engines; 3,350-pound minimum.
- BS - 9.50 to 10.49 pounds per cubic inch. Small-block wedge or canted-valve engines under 366 cubic inches original production; 3,000-pound minimum.

- CS - 10.50 or more pounds per cubic inch. Small-block true wedge engines (inline valves) under 366-cid original production; 3,000-pound minimum.
- DS - 12.00 or more pounds per cubic inch. V-6 engine; 2,900 pound minimum.
- ES - 15.50 to 16.49 pounds per cubic inch with a maximum displacement of 165 cubic inches. 4-cylinder only.
- FS - 16.50 pounds per cubic inch with a maximum displacement of 155 cubic inches.
- GS - 18.00 pounds per cubic inch, 4-cylinder, front-wheel drive only. Maximum displacement of 230 cubic inches.

REQUIREMENTS & SPECIFICATIONS

ENGINE: 1

CARBURETOR

Class A, one NHRA-accepted 4-barrel, maximum 850cfm, standard OEM configuration. Class B, C, and D, one NHRA accepted 4-barrel, maximum 750cfm, standard OEM configuration. Class A through D, throttle bore restricted to manufacturer's dimension, measured at the largest point, venturi restricted to manufacturer's dimension plus .025-inch measured at the largest point. Minimum throttle shaft diameter .085-inch, measured at thinnest point; minimum throttle-plate thickness .040-inch, measured at thinnest point. Throttle plates must be screwed to shaft; no welding. Polishing and booster changes permitted. Choke plate may be removed. ES limited to two injector-type throttle body fuel injectors, two Weber 45s, or one four-barrel American production carburetor, 600cfm maximum, accepted by NHRA. FS and GS, any carburetor or fuel injection allowed.

CYLINDER HEADS

V-8 splayed valve permitted in AS, canted or inline in BS, inline only in CS, and any valve configuration in DS. All heads must be NHRA-accepted, two valves per cylinder, except in classes DS, ES, FS, and GS, four valves per cylinder permitted. Aftermarket aluminum cylinder heads permitted (no billet) except in CS. Angle milling and/or rolling permitted. Aftermarket iron heads permitted in CS. Porting, polishing permitted; header plates permitted. Exhaust port plates that protrude into port prohibited. Any valve size permitted, valves may be tilted and/or canted. Combustion-chamber modifications permitted. The valve cover rail may be modified. Heads may be cut for larger pushrods and valve springs. External modifications permitted in port area except for SS/CS. Spark plug holes must be in NHRA-approved location.

ENGINE

OEM aftermarket small-block Chevrolet (SBC) engines with bore centers greater than 4.420 inches are not permitted. Engine must be same corporate make as body, naturally aspirated. Displacement unlimited in AS, limited to 366-cid original-production in BS and CS. Engine setback or raising engine prohibited. Motor plates and mid-mounts permitted. Timing-belt covers optional. Harmonic balancer meeting SFI Spec 18.1 mandatory. In Section 9A, Connecting Rods, Gaskets, Intake Manifold, Oil Pan, Pistons, Superseded/Replacement Parts do not apply in Section 9D. See General Regulations 1:2.

FAN, GENERATOR, WATER PUMP

Use of "smog pump" or air pump for crankcase evacuation permitted.

FUEL SYSTEM

Any mechanical fuel pump and/or two electric fuel pumps

permitted. Must be installed outside of passenger or trunk area, away from tires and suspension. Electric pump must shut off with car's ignition switch. Fuel lines may be changed to any size metallic line with in-line fuel filters and pressure regulators permitted; a maximum 12 inches of rubber lines for vibration connections is permitted. One cool can permitted. See General Regulations 1:5.

INTAKE MANIFOLD

Sheet-metal intake manifold permitted.

OIL PUMP

External single-stage oil pump permitted.

OIL SYSTEM

Dry-sump system allowed in ES, FS, and GS.

DRIVETRAIN: 2

REAR END

Any automotive type permitted. See General Regulations 2:11.

TRANSMISSION, AUTOMATIC

Automatic transmission flexplate meeting SFI Spec 29.1 mandatory in AS, BS, and CS. Parking gear not required. Any OEM or NHRA-accepted transmission permitted; maximum three forward speeds. ES, FS, and GS will be allowed a weight reduction for using an automatic transmission. See General Regulations 2:12, 2:14.

TRANSMISSION, MANUAL

Aftermarket transmission permitted; maximum four forward speeds. All gear changes must result from direct action by the driver. Pneumatic, hydraulic, electric, etc. shifters prohibited. Clutchless transmissions permitted. Clutch-assisted automatic transmissions use stick-shift weight break. ES through GS, five forward speeds maximum. See General Regulations 2:12.

TRANSMISSION SHIELD

Transmission shield meeting SFI Spec 4.1 mandatory. Automatic transmission flexplate shield meeting SFI Spec 30.1 mandatory in AS, BS, and CS.

BRAKES & SUSPENSION: 3

STEERING, FWD CONVERSIONS

May be relocated. Fabricated crossmember may be installed. Aftermarket steering permitted. OEM lower A-arms mandatory. See General Regulations 3:3.

SUSPENSION, FRONT

For FWD conversions, aftermarket or OEM front suspension of a stock configuration is required. Replacement control arms permitted. A full-tube chassis prohibited. The chassis must be built around existing OEM body and must retain the as-built OEM upper frameroils in front of firewall. The mounting point of replacement lower control arms may be non-OEM. The use of adjustable heim (or heim-type) joints permitted.

Any OEM or aftermarket shock absorber of a stock type permitted. Any OEM or aftermarket bushings are permitted. All other components (i.e., upper A-arms, springs, rods, fasteners, etc.) must be steel unless material similar to the original/stock components is used.

The struts must mount to the as-built upper OEM location. The strut lower tower may be modified (i.e., existing holes slotted or enlarged), but may not be reconfigured (i.e., welded shut). The strut mount may utilize an adapter or plate on the underside of

the strut tower to facilitate camber/caster adjustment. Final strut installation must be in a manner such that removing the three bolts on top of the strut tower allows strut assembly removal.

Lift kits/travel limiters permitted. Sway bar optional.

RWD must retain complete stock front-suspension system or utilize an NHRA-accepted front suspension. Lower control arm may be machined for larger shock diameter and mount. Aftermarket steering permitted. See General Regulations 3:4.

WHEELIE BARS

May be 54 inches long or to rear bumper, whichever is longer. See General Regulations 3:6.

FRAME: 4

BUMPER

The front and rear bumpers must be attached to the chassis using the OEM impact bars. The bracing of the rear bumper can be reinforced by using aftermarket tubing and be attached to the rear frame section and body panels to retain exterior factory appearance. Inside front and rear bumpers must retain factory appearance. Covering of cavities prohibited.

Rear bumper cover only (i.e., not the bumper) may be notched or slotted for clearance around wheelie bars. Opening maximum is to allow for wheelie-bar movement only. Removal of rear bumper cover or trimming rear bumper cover the full width of wheelie bar prohibited.

FRAME, FWD CONVERSIONS

The forward stock frame/support assembly must be retained. It may be modified or trimmed for engine, exhaust header, etc. clearance. Aftermarket/fabricated forward-clip frame components of 2-inch x 3-inch x .083-inch wall steel or 2 1/2-inch O.D. x .120-wall steel maximum may be added to reinforce the as-built stock frame/support assembly. As-built OEM crossmembers may be relocated and/or trimmed for oil pan and/or engine clearance. The OEM engine cradle/lower (or inner) framersails may be retained, modified, or replaced.

ROLL BAR

Mandatory in ES through GS.

ROLL CAGE

Mandatory in AS through DS. Roll cage meeting SFI 25.4 or 25.5 is mandatory for all Super Stock cars running 8.49 or quicker. See General Regulations 4:4, 4:11, 10:6.

WEIGHT

Cars with fully automatic transmissions with converter may remove up to 5 percent or 250 pounds, whichever is less, from minimum class weight; may be under posted minimum weight. Cars weighed with driver; minimum weight includes driver.

WHEELBASE

Must retain stock wheelbase +/- 3/4in and tread width for car body used. Minimum wheelbase 93 inches. Minimum front wheel drive conversion wheelbase 96 inches. Maximum variation from left to right: 1 inch. See General Regulations 4:12.

TIRES & WHEELS: 5

TIRES

Tire tread may extend 1 inch outside of fender line in GS.

INTERIOR: 6**DASH**

Dash must remain as-built OEM, but may be removable. Removable dash must be securely attached, and any non-factory fasteners must be concealed to retain factory appearance. Aftermarket or non-OEM dash prohibited.

UPHOLSTERY

Must have full factory-type upholstery, including factory-type carpet, door panels, and headliner. Interior gutting prohibited. Replacement door panels and headliner permitted, but must be fully upholstered to retain OEM appearance. Carpet must cover entire floor and any floor chassis/frame components in the floor area within the driver's compartment.

BODY: 7**BODY**

Use of fiberglass restricted to hood. ES through GS, fiberglass or other lightweight components (carbon fiber prohibited) restricted to hood, fenders, splash pans, valance panels, and rear deck lid are permitted. See HOOD. Other lightweight components prohibited.

FENDERS

Inner fender panels may be relocated/trimmed on front-wheel-drive unibody vehicles from the front side of strut tower forward. Area may be enlarged for tire clearance, but must retain a finished, OEM appearance. Front and rear fenders may be opened for larger tires. Tire tread and wheel rim must be inside stock body or fender lines. Flaring or bulging fenders for wider tires prohibited. All opened or radiused fenders must be re-rolled. See General Regulations 7:3.

FIREWALL

The lower portion of the OEM firewall may be replaced with steel of equal or greater thickness than OEM. Chevy Cavaliers, Pontiac Grand Ams and Sunfires, and Ford Escorts may replace or relocate the firewall, provided the measurement from the rear of the radiator core support to the firewall is 34 inches maximum. For Chevy Cobalt the radiator core support to the firewall is 33 inches. For all others vehicles, firewall must be in the original location. A complete one-piece steel firewall that resembles OEM must be installed, welded in place, and sealed from the driver compartment. The firewall must extend to and attach to the floor. The firewall and mid-plate must be two separate pieces. All motor plates, mid-plates, etc. must be separate from and may not be attached to the firewall.

FLOOR

Stock mandatory. Floor-mounted clutch/brake pedals permitted. Headers must fit under stock floor location. The stock framerails from the firewall to the radiator support must retain stock attachment configuration, stock location, and stock dimensions. Frame may be notched for header clearance. Area from front spring mount of rear spring to rear of trunk may be sectioned in width to permit narrowing of rear frame. Cutting into stock floor for suspension members prohibited. Any protrusion in trunk may not be higher than top of stock framerail. Cover must be made of materials of 14- to 20-gauge thickness.

For FWD conversion cars, a driveshaft tunnel must be fabricated of same-as-OEM material minimum and must be fully welded to the as-built OEM floor. See General Regulations 7:5.

HOOD

Mandatory. Fiberglass permitted. Carburetor must be

completely covered by hood, bubble, or scoop, which must be part of car hood. Hood latches, hinges, springs, and brackets may be removed. Maximum of 11-inch hood scoop (hood to top of opening) with one opening permitted. Tilt or removable front ends prohibited. See General Regulations 7:6.

SPOILERS

Must be automotive production for body used. Complete package, front and rear, not required. Aftermarket rear spoiler permitted. Maximum length 6 inches as measured from deck lid to spoiler transition point, to rear edge of spoiler. May be no wider than deck lid. Maximum height of spill plate, 4 inches. If aftermarket spoiler is used, any OEM spoilers must be removed.

WHEELWELLS, REAR

Radiusing permitted.

WINDSHIELD, WINDOWS

Windows must be closed during competition; need not be operative. See General Regulations 7:8.

ELECTRICAL: 8

DISTRIBUTOR

Any battery-powered ignition system permitted. See General Regulations 8:3.

DRIVER: 10

CREDENTIALS

Valid NHRA competition license mandatory in AS, BS, and CS or for any car running 9.99 or quicker. See General Regulations 10:4.

PROTECTIVE CLOTHING

Jacket and pants meeting SFI Spec 3.2A/5 mandatory in AS, BS, CS, or any vehicle running 9.99 or quicker. Jacket and pants meeting SFI Spec 3.2A/1 mandatory in DS, ES, FS, GS or any vehicle running 10.00 to 11.49. SFI Spec 3.3/1 gloves mandatory in any vehicle running 9.99 or quicker. See General Regulations 10:10.

SECTION 12E MODIFIED TRUCK

Requirements and specifications for Modified Truck are the same as those for Modified Stock classes - Section 11D - with the following exceptions:

DESIGNATIONS

SS/TA, SS/TB, SS/TC, and SS/TD preceded by truck number.

Reserved for 1990 or later NHRA-accepted factory production pickup trucks, 1/2-ton or smaller. Sport Utility (Blazer, Explorer, Cherokee, etc.) prohibited. Body, engine, drivetrain, chassis, etc. may not be altered or relocated except as outlined in Requirements & Specifications. Classes of competition within Modified Truck are for non-supercharged trucks. Class determined by total truck weight (including driver) divided by total engine displacement (cubic inches).

CLASSES

TA - 8.50 to 9.49 or more pounds per cubic inch. Wedge, canted-valve or Hemi engines; 3,350-pound minimum.

- TB - 9.50 to 10.49 pounds per cubic inch. Small-block wedge or canted-valve engines under 366 cubic inches original production; 3,000-pound minimum.
- TC - 10.50 or more pounds per cubic inch. Small-block true wedge engines (inline valves) under 366-cid original production; 3,000-pound minimum.
- TD - 12.00 or more pounds per cubic inch. V-6 engine; 2,900-pound minimum.

REQUIREMENTS & SPECIFICATIONS

ENGINE: 1

CARBURETOR

Class TA, one NHRA-accepted 4-barrel, maximum 850cfm, standard OEM configuration. Classes TB, TC, and TD, one NHRA-accepted 4-barrel, maximum 750cfm, standard OEM configuration. Classes A through D, throttle bore restricted to manufacturer's dimension, measured at the largest point, venturi restricted to manufacturer's dimension plus .025-inch, measured at the largest point. Throttle plates must be screwed to shaft; no welding. Polishing and booster changes permitted. Choke plate may be removed.

CYLINDER HEADS

V-8 splayed valve permitted in TA, canted or inline in TB, inline only in TC, and any valve configuration in TD. All heads must be NHRA-accepted, two valves per cylinder. Aftermarket aluminum cylinder heads permitted (no billet) except in TC. Angle milling and/or rolling permitted. Porting, polishing permitted; header plates permitted. Exhaust port plates that protrude into port prohibited. Any valve size permitted, valves may be tilted and/or canted. Combustion-chamber modifications permitted. The valve cover rail may be modified. Heads may be cut for larger pushrods and valve springs. External modifications permitted in port area except for SS/TC. Spark plug holes must be in NHRA-approved location.

ENGINE

OEM aftermarket small-block Chevrolet (SBC) engines with bore centers greater than 4.420 inches are not permitted. Displacement unlimited in TA, limited to 366-cid original-production in TB and TC. Engine setback or raising engine prohibited. Motor plates and mid-mounts permitted. Timing-belt covers optional. Harmonic balancer meeting SFI Spec 18.1 mandatory. In Section 10A, Connecting Rods, Gaskets, Intake Manifold, Oil Pan, Pistons, Superseded/Replacement Parts do not apply in Section 10E. See General Regulations 1:2.

DRIVETRAIN: 2

TRANSMISSION, AUTOMATIC

Automatic transmission flexplate meeting SFI Spec 29.1 mandatory in TA, TB, and TC.

TRANSMISSION SHIELD

Transmission shield meeting SFI Spec 4.1 mandatory. Automatic transmission flexplate shield meeting SFI Spec 30.1 mandatory in TA, TB, and TC.

BRAKES & SUSPENSION: 3

SUSPENSION, FRONT

Must retain complete stock front-suspension system as produced by manufacturer for body used. Lift kits/travel limiters permitted. Sway bar optional. Lower control arm may be machined for larger shock diameter and mount. Aftermarket steering permitted. See General Regulations 3:4.

FRAME: 4**ROLL CAGE**

Roll cage mandatory in SS/TA and SS/TB or any truck running 9.99 seconds or quicker. Roll cage meeting SFI 25.4 or 25.5 is mandatory for all Super Stock vehicles running 8.49 or quicker. See General Regulations 4:4, 4:11, 10:6.

ROLL BAR

Roll bar mandatory in SS/TC and SS/TD or any truck running 11.49 seconds or quicker. Roll cage meeting SFI 25.4 or 25.5 is mandatory for all Super Stock vehicles running 8.49 or quicker. See General Regulations 4:10.

WEIGHT

Trucks with fully automatic transmissions with converter may remove up to 5 percent or 250 pounds, whichever is less, from regular class weight; may be under posted minimum weight. Trucks weighed with driver; minimum weight includes driver.

WHEELBASE

Must retain stock wheelbase +/- 3/4in and tread width for truck body used. Minimum wheelbase 97 inches. Maximum variation from left to right: 1 inch.

BODY: 7**HOOD**

Mandatory. Fiberglass permitted. Hood scoop prohibited. Hood latches, hinges, springs, and brackets may be removed. Tilt or removable front ends prohibited. Cowl-induction hood permitted. See General Regulations 7:6.

SPOILERS

Aftermarket rear spoiler permitted, maximum length 6 inches as measured from tailgate to spoiler transition point to rear edge of spoiler. Must be mounted to tailgate. May be no wider than tailgate.

WINDSHIELD, WINDOWS

Rear window may be replaced with a clear, shatterproof material such as Lexan or Plexiglas, 1/8-inch-minimum thickness. See General Regulations 7:8.

ELECTRICAL: 8**MASTER CUTOFF**

Mandatory on all trucks with battery in the trunk. See General Regulations 8:4.

DRIVER: 10**CREDENTIALS**

Valid NHRA competition license mandatory in TA, TB, and TC or for any car running 9.99 or quicker. See General Regulations 10:4.

PROTECTIVE CLOTHING

Jacket and pants meeting SFI Spec 3.2A/5 mandatory. SFI Spec 3.3/1 gloves mandatory in any vehicle running 9.99 or quicker. See General Regulations 10:10.

SECTION 12F MODIFIED

Requirements and specifications for Modified classes are the same as those for Super Stock classes - Section 11A - with the following exceptions:

DESIGNATIONS

SS/AM, SS/BM, SS/CM, SS/DM, SS/EM, SS/FM, and SS/GM, preceded by car number.

Reserved for factory production-built cars with automobile production engines. Body, drivetrain, chassis, etc. may not be altered, modified, or relocated except as outlined in Requirements & Specifications. Minimum wheelbase: 96 inches.

Classes of competition within Modified are for non-supercharged cars. Class determined by total car weight (including driver) divided by total engine displacement (cubic inches). Front-wheel-drive conversions permitted.

CLASSES

- AM: 7.50 to 8.49 pounds per cubic inch; 2,650-pound minimum
- BM: 8.50 to 9.49 pounds per cubic inch; 2,750-pound minimum
- CM: 9.50 to 10.49 pounds per cubic inch; 2,850-pound minimum
- DM: 10.50 to 11.49 pounds per cubic inch; 2,950-pound minimum
- EM: 11.50 to 12.49 pounds per cubic inch
- FM: 12.50 to 13.49 pounds per cubic inch
- GM: 10.50 or more pounds per cubic inch, for non-supercharged, inline 4- and 6-cylinder and straight-8 engines with stock, production-type heads
- GM: 11.00 or more pounds per cubic inch for non-supercharged, American factory controlled V-6s

REQUIREMENTS & SPECIFICATIONS

ENGINE: 1

CARBURETOR

Two NHRA-accepted American-production 4-barrel or three American production 2-barrel carburetors maximum. Inline 4-barrel carburetor prohibited. Fuel injection prohibited.

CYLINDER HEADS

V-8 splayed valve permitted in AM and BM, canted or inline in CM through FM, and any valve configuration in GM with V-6 engine. All heads must be NHRA-accepted, two valves per cylinder. Aftermarket aluminum cylinder heads permitted (no billet). Any valve size permitted, valves may be tilted and/or canted. Porting, polishing permitted; header plates permitted. Exhaust port plates that protrude into port prohibited. Spark plug holes must be in the NHRA-approved location. Angle milling and/or rolling permitted. The valve cover rail may be modified.

ENGINE

Must be standard, naturally aspirated, automobile production engine, same make as car; year and model optional. One engine only. Raising engine prohibited. OEM bore center spacing mandatory. OEM aftermarket small-block Chevrolet (SBC) engines with bore centers greater than 4.420 inches

are not permitted. Rear-engine location prohibited unless originally produced as rear-engine car and original engine has been retained. Engine may be set back, provided all rules as outlined under FIREWALL are followed. Harmonic balancer meeting SFI Spec 18.1 mandatory. In Section 9A, Connecting Rods, Gaskets, Intake Manifold, Oil Pan, Pistons, Superseded/Replacement Parts do not apply in Section 9F. See General Regulations 1:2.

FAN, GENERATOR, WATER PUMP

Use of "smog pump" or air pump for crankcase evacuation permitted.

FUEL SYSTEM

Any mechanical fuel pump and/or two electric fuel pumps permitted. Must be installed outside of passenger area, away from tires and suspension. Electric pump must shut off with car's ignition switch. Fuel lines may be changed to any size metallic line with in-line fuel filters and pressure regulators permitted; a maximum 12 inches of rubber lines for vibration connections is permitted. One cool can permitted. See General Regulations 1:5.

OIL SYSTEM

External single-stage oil pump permitted.

RADIATOR

May be moved to permit installation of longer engine. Radiator splash pans may be cut for clearance.

DRIVETRAIN: 2

REAR END

Any automotive type permitted. See General Regulations 2:11.

TRANSMISSION, AUTOMATIC

Automatic transmission flexplate meeting SFI Spec 29.1 mandatory. Parking gear not required. Any OEM or NHRA-accepted transmission permitted; maximum three forward speeds. See General Regulations 2:12, 2:14.

TRANSMISSION, MANUAL

Aftermarket transmission permitted; minimum three, maximum five, forward speeds. All gear changes must result from direct action by the driver. Pneumatic, hydraulic, electric, etc. shifters prohibited. Clutchless transmissions permitted. Clutch-assisted automatic transmissions use stick-shift weight break. See General Regulations 2:12.

TRANSMISSION SHIELD

Transmission shield meeting SFI Spec 4.1 mandatory. Automatic transmission flexplate shield meeting SFI Spec 30.1 mandatory.

BRAKES & SUSPENSION: 3

STEERING, FWD CONVERSIONS

May be relocated. Fabricated crossmember may be installed. Aftermarket steering permitted. OEM lower A-arms mandatory. See General Regulations 3:3.

SUSPENSION, FRONT

For FWD conversions, aftermarket or OEM front suspension of a stock configuration is required. Replacement control arms permitted. A full-tube chassis prohibited. The chassis must be built around existing OEM body and must retain the as-built OEM upper frameroils in front of firewall. The mounting point of replacement lower control arms may be non-OEM. The use of adjustable heim (or heim-type) joints permitted.

Any OEM or aftermarket shock absorber of a stock type permitted. Any OEM or aftermarket bushings are permitted. All

other components (i.e., upper A-arms, springs, rods, fasteners, etc.) must be steel unless material similar to the original/stock components is used.

The struts must mount to the as-built upper OEM location. The strut lower tower may be modified (i.e., existing holes slotted or enlarged), but may not be reconfigured (i.e., welded shut). The strut mount may utilize an adapter or plate on the underside of the strut tower to facilitate camber/caster adjustment. Final strut installation must be in a manner such that removing the three bolts on top of the strut tower allows strut assembly removal.

Lift kits/travel limiters permitted. Sway bar optional.

RWD must retain complete stock front-suspension system or utilize an NHRA-accepted front suspension. Lower control arm may be machined for larger shock diameter and mount. Aftermarket steering permitted. See General Regulations 3:4.

WHEELIE BARS

May be 54 inches long or to rear bumper, whichever is longer.

FRAME: 4

BUMPER

The front and rear bumpers must be attached to the chassis using the OEM impact bars. The bracing of the rear bumper can be reinforced by using aftermarket tubing and be attached to the rear frame section and body panels to retain exterior factory appearance. Inside front and rear bumpers must retain factory appearance. Covering of cavities prohibited.

Rear bumper cover only (i.e., not the bumper) may be notched or slotted for clearance around wheelie bars. Opening maximum is to allow for wheelie-bar movement only. Removal of rear bumper cover or trimming rear bumper cover the full width of wheelie bar prohibited.

FRAME, FWD CONVERSIONS

The forward stock frame/support assembly must be retained. It may be modified or trimmed for engine, exhaust header, etc. clearance. Aftermarket/fabricated forward-clip frame components of 2-inch x 3-inch x .083-inch wall steel or 2 1/2-inch O.D. x .120-wall steel maximum may be added to reinforce the as-built stock frame/support assembly. As-built OEM crossmembers may be relocated and/or trimmed for oil pan and/or engine clearance. The OEM engine cradle/lower (or inner) framrails may be retained, modified, or replaced.

PARACHUTE

Mandatory in AM and BM. See General Regulations 4:8.

ROLL CAGE

Mandatory. Roll cage meeting SFI 25.4 or 25.5 is mandatory for all Super Stock cars running 8.49 or quicker. See General Regulations 4:4, 4:11, 10:6.

WEIGHT

Cars with fully automatic transmissions with converter may remove up to 5 percent or 250 pounds, whichever is less, from regular class weight; may be under posted minimum weight. Cars weighted with driver; minimum weight includes driver.

WHEELBASE

Must retain stock wheelbase +/- 3/4-inch for body used. Minimum 96 inches. Front-wheel-drive conversion wheelbase, minimum 96 inches. Maximum wheelbase variation from left to right: 1 inch.

TIRES & WHEELS: 5**TIRES**

Any size slicks that fit in original outer wheelwell permitted. Inner wheelwells in rear may be altered; must be completely finished as originally produced. Outside of tire must be within 3 inches of inside of fender at widest point of fender. See FENDERS for restrictions. See General Regulations 5:1.

WHEELS

Aftermarket street wheels permitted. Minimum diameter: 13 inches. Automotive-type wire wheels or motorcycle wheels prohibited. See General Regulations 5:2.

INTERIOR: 6**DASH**

Dash must remain as-built OEM, but may be removable. Removable dash must be securely attached, and any non-factory fasteners must be concealed to retain factory appearance. Aftermarket or non-OEM dash prohibited.

UPHOLSTERY

Must have full factory-type upholstery, including factory-type carpet, door panels, and headliner. Interior gutting prohibited. Replacement door panels and headliner permitted, but must be fully upholstered to retain OEM appearance. Carpet must cover entire floor and any floor chassis/frame components in the floor area within the driver's compartment.

WINDOW NET

A ribbon-type or SFI 27.1 mesh-type window net is mandatory. See General Regulations 6:3.

BODY: 7**BODY**

Production sports cars, pickups (Ranchero, El Camino, etc.) permitted. Use of fiberglass restricted to hood. See HOOD. Other lightweight components prohibited.

FENDERS

Inner fender panels may be relocated/trimmed on front-wheel-drive unibody vehicles from the front side of strut tower forward. Area may be enlarged for tire clearance, but must retain a finished, OEM appearance. Front and rear fenders may be opened for larger tires. Tire tread and wheel rim must be inside stock body or fender lines. Flaring or bulging fenders for wider tires prohibited. All radiused fenders must be re-rolled. See General Regulations 7:3.

FIREWALL

Firewall may be recontoured for distributor or magneto clearance only, and must be properly refinished. The lower portion of the OEM firewall may be replaced with steel of equal or greater thickness than OEM. Chevy Cavaliers, Pontiac Grand Ams and Sunfires, and Ford Escorts may have firewall replaced or relocated, provided the measurement from the rear of the radiator core support to the firewall is 34 inches maximum. For Chevy Cobalt the radiator core support to the firewall is 33 inches maximum. For all others vehicles, firewall must be in the original location. A complete one-piece steel firewall that resembles OEM must be installed, welded in place, and sealed from the driver compartment. The firewall must extend to and attach to the floor. The firewall and mid-plate must be two separate pieces. All motor plates, mid-plates, etc. must be separate from and may not be attached to the firewall. Additional alterations prohibited. Engine must not touch firewall. Firewall coverings prohibited. See General Regulations 7:4.

FLOOR

Stock mandatory. Floor-mounted clutch/brake pedals permitted. Headers must fit under stock floor location. The stock frameroils from the firewall to the radiator support must retain stock attachment configuration, stock location, and stock dimensions. Frame may be notched for header clearance.

For FWD conversion cars, a driveshaft tunnel must be fabricated of same-as-OEM material minimum and must be fully welded to the as-built OEM floor. See General Regulations 7:5.

HOOD

Mandatory; fiberglass permitted. Carburetors must be completely covered by hood, bubble or scoop, one opening only, which must be part of car hood. Hood latches, hinges, springs, and brackets may be removed. Tilt or removable front ends prohibited.

SPOILERS

Front spoiler must be automotive production for body used. Aftermarket rear spoiler limited to maximum length 6 inches as measured from deck lid to spoiler transition point, to rear edge of spoiler. May be no wider than deck lid. Maximum height of spill plate, 4 inches. If aftermarket spoiler is used, any OEM spoilers must be removed.

WINDSHIELD, WINDOWS

Windows must be closed during competition; need not be operative. Window-operating mechanism may be removed. See General Regulations 7:8.

ELECTRICAL: 8**DISTRIBUTOR**

Any battery-powered ignition system permitted. See General Regulations 8:3.

DRIVER: 10**CREDENTIALS**

Valid NHRA competition license mandatory. See General Regulations 10:4.

PROTECTIVE CLOTHING

Jacket and pants meeting SFI Spec 3.2A/5 mandatory. SFI Spec 3.3/1 gloves mandatory in any vehicle running 9.99 or quicker. See General Regulations 10:10.

SECTION 12G SUPER STOCK/MX

Requirements and specifications for MX classes are the same as those for Modified Stock and Modified classes - Sections 11D and 11F - with the following exceptions:

DESIGNATIONS

SS/AX, SS/BX, SS/CX, SS/DX, SS/EX, and SS/VX preceded by car number.

Classes of competition within Super Stock/MX are for non-supercharged 4- and 6-cylinder-powered cars. Class

determined by total car weight (including driver) divided by total engine displacement (cubic inches). Front-wheel-drive conversions permitted.

CLASSES

- AX: 8.50 to 10.99 pounds per cubic inch
- BX: 11.00 to 12.49 pounds per cubic inch
- CX: 12.50 or more pounds per cubic inch
- DX: 15.00 or more pounds per cubic inch, two turbochargers or OEM supercharger. Turbochargers must be run "dry"; fluid-injection prohibited
- EX: 11.50 or more pounds per cubic inch, naturally aspirated, methanol only, front-wheel-drive only, full-bodied
- VX: 12.00 or more pounds per cubic inch, naturally aspirated, air-cooled, Volkswagen, rear-engine, full-bodied

REQUIREMENTS & SPECIFICATIONS

ENGINE: 1

CAMSHAFT/LIFTERS

VX class: Flat tappet cam with flat tappet lifters mandatory. Maximum lift at the valve 0.645-inch.

CARBURETOR

Any standard OEM carburetor(s) permitted. Carb manufacturer must be represented in NHRA Blueprint Bulletins.

VX class: Maximum two only, single- or two-barrel downdraft Kadron, Weber, Dellorto, or Empi carburetors. Maximum 52mm (2.047 inches) throttle bore and 44mm (1.732 inches) venturis.

CYLINDER HEADS

OEM casting with OEM number cast into head. Two- or four-valve permitted, any valve size permitted, valves may be tilted and/or canted, porting, polishing permitted; header plates permitted. Exhaust port plates that protrude into port prohibited.

VX class: Stock intake flange Volkswagen-type cylinder heads mandatory. Stud pattern must be in OEM location with OEM dimensions. Studs must be used to mount the manifold to the cylinder head. Welding to increase, or originally filled, manifold flange area permitted. Maximum intake valve head diameter 44.1mm (1.736 inches), maximum exhaust valve head diameter 37.5mm (1.476 inches). Minimum valve stem diameter 5/16-inch. Titanium valves, retainers, and keepers permitted. Steel pushrods mandatory.

ENGINE

One automobile engine only, naturally aspirated (AX, BX, and CX). Engine may be relocated, not to exceed 10 percent of wheelbase as measured from centerline of front spindles to nearest engine spark-plug hole. Four- or six-cylinder opposed rear-engine installations permitted. Engine must be of same type as car model and must be in stock location except front-to-rear-drive conversions, a permitted modification. All conversions must use the OEM engine as car model and must meet the maximum 10 percent engine setback rule. Harmonic balancer meeting SFI Spec 18.1 mandatory. See General Regulations 1:2.

EX class: Engine must be from same manufacturer as body. 4-cylinder engine only; all others prohibited. All engine-block and cylinder-head castings must be, or have been, available in a production car or truck from a recognized OEM assembly line with a minimum production run of 5,000 units. Fuel injection permitted.

Fuel: methanol only.

VX class: Naturally aspirated, air-cooled, OEM Volkswagen. Maximum engine size 2,444cc (149 cid). Maximum bore diameter 94.1mm (3.705 inches). Cast-iron or steel cylinders and steel connecting rods mandatory. Vacuum pump prohibited. Oil-retention device mandatory; device must extend from midplate rearward past crankshaft pulley and must incorporate a minimum 2-inch-high lip on all sides. Nonflammable, oil-absorbent liner is mandatory inside of device.

INDUCTION

Electronic fuel injection permitted. Any induction system permitted. See General Regulations 9:1, 9:11.

OIL SYSTEM

Dry-sump oil system permitted.

ROCKER ARMS

VX class: OEM-style rocker arm mounting and dimensions mandatory. End supports permitted.

TURBOCHARGERS

Permitted in DX only. Must be no larger than the T04-b or the 300 Series Rotomaster/Garrett, twin 62mm or single 80mm maximum size. Air-to-air or water-to-air intercooler permitted on turbocharged SS/DX vehicles.

DRIVETRAIN: 2

REAR END

Quick-change rear ends permitted if installation includes axle-retention device. See General Regulations 2:11.

TRANSMISSION, MANUAL

Maximum five forward speeds permitted on manual transmissions; reverse mandatory. Clutch automatics run at stick-shift weight.

EX class: Manual transmission only with two-disc clutch maximum. All cars must be equipped with a flywheel shield made of 1/4-inch-minimum-thickness steel plate. In lieu of steel plate, an SFI Spec 4.1 blanket will be accepted if blanket adequately covers bellhousing. Shield must surround the bellhousing completely except for area of flywheel shield adjacent to differential and axle shaft. Shield may be multipiece, with pieces bolted together using minimum 3/8-inch-diameter Grade 5 bolts; may be attached to engine and/or bellhousing.

VX class: Manual transmission mandatory with a maximum of four forward speeds. Single-disc, nonadjustable lever-type clutch permitted. Clutchless or sequential transmissions prohibited. Pneumatic or electronically controlled shifting prohibited. Clutch must be manually operated by the driver's foot. Washington anti-shocker hydraulic clutch management system permitted. The cylinder must be preset and remain in a fixed position during the run. Any adjustment during the run prohibited.

TRANSMISSION SHIELD

Automatic transmission flexplate meeting SFI Spec 29.1 mandatory in AX through DX. Automatic transmission flexplate shield meeting SFI Spec 30.1 mandatory in AX through DX.

BRAKES & SUSPENSION: 3

SUSPENSION, FRONT

EX class: Upper mounting point for strut assemblies must be in the factory location. Front and rear sides of strut tower may be "notched" for tire clearance, and area must be refinished with minimum .024-inch steel. Roll-cage tubing may run across

top of strut tower and attach to frame horn. Adjustable caster/camber pillow ball mounts are permitted. Lower control arm may be strengthened provided factory mounting points to chassis are maintained. Aftermarket or fabricated lower control arms permitted; must use original mounting points. Lower mounting point for strut assembly may be modified for improved caster or camber. Strut tower braces, lower tie bars, sway bars, and limit straps permitted. Traction bars/devices permitted; must be bolt-on ONLY. Final decision rests with NHRA Technical Services. All front suspensions must utilize one, and only one, working shock absorber/strut per wheel. Shock/strut must attach to original OEM upper mount and maintain minimum 1-inch travel.

VX class: OEM-type suspension and dimensions for model year claimed mandatory. Coilovers, longer spring plates, etc. prohibited. Raising and narrowing permitted.

SUSPENSION, REAR

EX class: Factory-independent rear suspension may be replaced with straight-axle suspension but must retain original mounting points. Strut must mount to original upper mounting point.

VX class: OEM-type suspension and dimensions for model year claimed mandatory. Coilovers, longer spring plates, etc. prohibited. Raising and narrowing permitted.

WHEELIE BARS

EX, VX class: Permitted. Maximum length 65 inches from rear bumper.

FRAME: 4

BUMPERS

Required.

FRAME

Stock, altered automotive-type or tubular frame construction permitted. Minimum thickness: .083-inch.

ROLL BAR

Mandatory in CX and VX. See General Regulations 4:10.

ROLL CAGE

Mandatory in AX, BX, and DX. Roll cage meeting SFI 25.4 or 25.5 is mandatory for all Super Stock cars running 8.49 or quicker. See General Regulations 4:4, 4:11, 10:6.

WEIGHT

Minimum weight: 1,700 pounds for 6-cylinder cars; 1,200 pounds for 4-cylinder cars; VX class, 1,600 pounds. All weight minimums are with driver. Cars with fully automatic transmission with converter may remove 100 pounds from regular class weight; may be under posted minimum weight. Cars weighed with driver; class minimum includes driver.

CHASSIS, ALL CARS

EX class: Must retain FWD configuration; rear-drive conversions prohibited. Roll cage mandatory for all cars. Roll cage must be recertified every three years and have serialized sticker affixed to roll cage before participation. Excessive lightening of unibody structure (i.e., drilling of holes, etc.) prohibited. Center driver position prohibited. Driver must be located completely to the left or right of vehicle centerline. Engine must be located in OEM orientation for body used. Conversion from transverse to longitudinal engine orientation prohibited. Wheel tubs, back halves, tube chassis, etc. permitted.

WHEELBASE

Must retain stock wheelbase and tread width for body used,

minimum 90 inches. Front tread width must remain within 3 inches of stock. Any non-supercharged sports car with original engine, no minimum. Axles, body location must remain stock. Maximum wheelbase variation from left to right: 1 inch.

EX class: Must retain original wheelbase for body used, plus or minus 1 inch. Maximum wheelbase variation from left to right is 1 inch.

TIRES & WHEELS: 5

TIRES

VX class: Street-type or drag slicks, maximum 10-inch tread width.

WHEELS

Minimum wheel size 13 inches, unless car was originally equipped with smaller wheels and is using original engine. See General Regulations 5:2.

INTERIOR: 6

UPHOLSTERY

Dashboard exterior appearance must be retained. See General Regulations 6:2.

EX and VX classes: Upholstery, headliners, carpets, dashboard, etc. optional. Must be equipped with one seat minimum for driver, properly installed. Holes, slots, or other openings in floor and/or firewall prohibited.

BODY: 7

BODY

Must have coupe or sedan body originally produced by an automobile manufacturer. Top may be chopped a maximum of 4 inches; must retain original windshield and rear window angle. Body cannot be otherwise altered in height, width, length, or contour. Fiberglass for hood, trunk lid, grille, shell, and doors permitted if stock appearance is retained. Full-fendered, steel-bodied roadsters and convertible coupes/sedans permitted with full top and windshield.

EX class: Body must be on NHRA Accepted Bodies list. Pickup and SUV bodies prohibited. Convertible permitted, but must run with top up. Doors must open and close from inside and outside. Glass may be replaced with Lexan or other shatterproof material, minimum thickness 1/8-inch. Side windows need not be operative, but must be in fully closed position for run. Lightweight body panels permitted. Body must retain a finished appearance, with full fenders, hood, bumpers (or fascia kits), and paint. Air intake tube may not be routed outside of body, hood scoop permitted. Otherwise, only factory air-inlet openings permitted.

VX class: Full-bodied, rear-engine, Volkswagen. Carbon fiber or fiberglass replacement body pieces permitted. Deck lid mandatory.

FENDERS

Four full stock-production fenders mandatory for body used. Exact duplicates in fiberglass permitted. Bubbles or scoops for wider or taller tires prohibited. Rear fenders may be cut for clearance of wide slicks. See General Regulations 7:3.

FIREWALL

Mandatory. EX class: Replacement steel firewall permitted. See General Regulations 7:4.

FLOOR

Mandatory. EX class: Horizontal portion(s) of floor pan may be removed from behind B-post or roll-cage main-hoop attachment points (whichever is farther rearward) to rear of car. Entire shock/strut tower structure must be retained. Portion of floor removed must be replaced with aluminum or steel, completely sealed. Excessive lightening of unibody structure, i.e., drilling of holes, etc., prohibited. See General Regulations 7:5.

HOOD

Mandatory. Carburetors and fuel injectors must be completely covered by bubble or scoop, one opening only, which must be part of hood. Injector tubes may extend through hood. Maximum clearance around tubes: 2 inches. Holes for valve covers, magnetos, etc. prohibited. Flash shields extending through hood prohibited.

SPOILER

Front spoiler must have been factory available for body used. Aftermarket rear spoiler permitted. Maximum length 6 inches as measured from deck lid to spoiler transition point, to rear edge of spoiler. May be no wider than deck lid. Maximum height of spill plate, 4 inches. If aftermarket spoiler is used, any OEM spoilers must be removed.

WINDSHIELD, WINDOWS

Windows may be replaced with clear Plexiglas or Lexan, 1/8-inch-minimum thickness. Windshields may not be cut for injector stack, carburetor, or ignition clearance. Windows must be closed during competition; need not be operational. See General Regulations 7:8.

STREET EQUIPMENT

Two headlights and taillights must be present or painted on; need not be operational except for one working taillight.

SUPPORT GROUP: 9**FIRE EXTINGUISHER SYSTEM**

EX class: Minimum 5-pound, NHRA-accepted fire extinguishing system mandatory. System must be divided with one nozzle on driver's side and one nozzle on engine. See General Regulations 9:3 for NHRA-accepted fire extinguishing agents.

DRIVER: 10**CREDENTIALS**

Valid NHRA competition license mandatory in AX, BX, DX, and EX. See General Regulations 10:4.

DRIVER

Must be in stock location. Seat(s) may be moved to rear for additional legroom, not to exceed 10 inches from stock placement.

PROTECTIVE CLOTHING

Jacket and pants meeting SFI Spec 3.2A/5 mandatory in AX, BX, DX, EX, or any vehicle running 9.99 or quicker. Jacket and pants meeting SFI Spec 3.2A/1 mandatory in CX and VX. Gloves and boots/shoes meeting SFI Spec 3.3/1 mandatory in EX. SFI Spec 3.3/1 gloves mandatory in any vehicle running 9.99 or quicker. See General Regulations 10:10.

NECK COLLAR

See General Regulations 10:8.



SECTION 13 COMP

Comp category is for qualified cars in Gas Dragster, Econo Dragster, Nostalgia Dragster, Altered, Street Roadster, Altered Truck, Econo Altered and Funny Car, Super Modified, and Pro Modified. Eliminations are based on a handicap start using the NHRA index system; breakout does not apply.

Any competitor who causes an oildown while participating at an NHRA Mello Yello event will be subject to fines and penalties as outlined in Section 2 - Oildown Penalties.

All requirements and specifications contained in Section 12 - Comp apply to all subcategories of Section 12 unless otherwise noted in the subsection.

REQUIREMENTS & SPECIFICATIONS

ENGINE: 1

ENGINE

For Econo Dragster, Altered Truck, Econo Altered, and Super Modified classes: OEM aftermarket small-block Chevrolet (SBC) engines with bore centers greater than 4.400 inches, maximum 4.500 inches, are permitted only in A/ED, P/ST, P/STA, A/EA, A/SM, A/SMA, B/SM, B/SMA, C/SM, and C/SMA. SBC engines with bore centers greater than 4.400 inches are permitted in all V-8 Dragster and V-8 Altered classes; not permitted in any Nostalgia Dragster classes. All classes except A/A, A/AA, A/AP, A/PM, AA/AM, AA/AT, BB/A, CC/A, BB/AM, BB/AT, CC/AT, DD/AT, B/A, B/AP, C/A, D/A, E/A, F/A, G/A, H/A, I/A, J/A, K/A, L/A, A/AA, B/AA, C/AA, D/AA, E/AA, F/AA, G/AA, H/AA, I/AA, J/AA, K/AA, and L/AA are restricted to an absolute maximum bore center of 5.000 inches. Classes A/A, A/AA, A/AP, A/PM, AA/AM, AA/AT, BB/A, CC/A, BB/AM, BB/AT, CC/AT, DD/AT, B/A, B/AP, C/A, D/A, E/A, F/A, G/A, H/A, I/A, J/A, K/A, L/A, A/AA, B/AA, C/AA, D/AA, E/AA, F/AA, G/AA, H/AA, I/AA, J/AA, K/AA, and L/AA are restricted to an absolute maximum bore center of 5.300 inches.

EXHAUST SYSTEM

Competition exhaust systems permitted. Exhaust must be directed out of body to rear, away from driver and fuel tank. See General Regulations 1:3.

FUEL SYSTEM

Fuel lines must be isolated from driver compartment. Artificial cooling or heating of fuel prohibited. Circulating pumps prohibited. See General Regulations 1:5.

HARMONIC BALANCER

Harmonic balancer meeting SFI Spec 18.1 or solid hub mandatory.

LIQUID OVERFLOW CONTROL

Mandatory.

OIL-RETENTION DEVICE

All vehicles must utilize an NHRA-accepted lower engine oil-retention device; may use a belly pan in lieu of a device attached to the engine. Pan must run from in front of the front motor plate to in front of the rear motor plate and from framerail to framerail. On vehicles without a front motor plate, pan must run from in front of harmonic balancer to in front of rear motor plate and from framerail to framerail. All belly pans must incorporate a minimum 2-inch-high lip on all sides. Minimum number of slots or holes in the walls to clear frame, steering, or lines permitted. A nonflammable, oil-absorbent liner mandatory inside of retention device. See General Regulations 1:8.

THROTTLE

Throttle control must be manually operated by driver's foot. Electronics, pneumatics, hydraulics, or any other device may in no way affect the throttle operation. NHRA-accepted physically challenged hand controls permitted. See General Regulations 1:12.

TURBOCHARGERS

Turbocharger size will be verified by measuring the housing bore at the leading edge of the impeller wheel. The maximum diameter of the housing bore at the leading edge of the wheel may not exceed 2mm more than the maximum allowable turbocharger size permitted.

DRIVETRAIN: 2**REAR END**

Aftermarket axles and axle-retention device mandatory. Spool permitted. See General Regulations 2:2, 2:11.

TRANSMISSION, GENERAL

Lockup converter prohibited. Air-shifter bottles must be permanently mounted (hose clamps or tie wraps prohibited) and stamped as meeting DOT-1800 pound rating. Overdrive/underdrive units, motorcycle, snowmobile, or farm-implement-type transmission prohibited.

TRANSMISSION, AUTOMATIC

Where permitted by class regulations, an automatic transmission must meet the following criteria: any automotive production, automatic transmission with converter, maximum three forward speeds (Nostalgia Dragster limited to maximum two forward speeds). Full shift pattern mandatory. Automated, electric, or pneumatic shifter permitted (except A/ND and B/ND), must be controlled by preset engine rpm and/or time functions ONLY. Transmission brake permitted. Electric transbrake release system only. Transbrake buttons must be NHRA-accepted (see NHRARacer.com for accepted list). Devices must be mechanical-spring actuated and not exceed 3 inches in length from base of (button) switch to top of plunger. Adjustability is permitted and may be made by a thread stop or stop rings. Modifying the switch by the addition of hydraulics, pneumatics, electric, or other means is prohibited. Maximum one transmission brake solenoid permitted. Automatic

transmission flexplate meeting SFI Spec 29.1, automatic transmission flexplate shield meeting SFI Spec 30.1 and automatic transmission shield 4.1 mandatory. Aftermarket replacement transmission case, OEM replica and accepted by NHRA, permitted. See General Regulations.

TRANSMISSION, MANUAL

Where permitted by class regulations, a manual transmission must meet the following criteria: any aftermarket planetary or clutchless manual transmission, maximum of five forward speeds. Reverse gear mandatory. Lenco drive or BRT drive unit and transbrake are permitted. Acceptable transbrake wiring and pneumatic schematics for the BRT drive and Quickdrive units are available in the Accepted Products list on NHRARacer.com. The Lencodrive uses a conventional electric transbrake system. Maximum one transmission brake solenoid permitted. Automated shifters and/or timer-type shifting devices prohibited; each individual shift must be a function of the driver. Shifting must be controlled by manual or pneumatic means only (driver pulls the lever or pushes the button); electric or electronics may in no way affect the shifting mechanism. See General Regulations 2:12, 2:13, 2:14.

BRAKES & SUSPENSION: 3

STEERING

A device (e.g., collapsing column or travel limiting device) must be used to limit rearward travel of long steering shaft and steering wheel in case of frontal impact. If removable steering wheel is used, commercially available quick-disconnect steering-wheel adapter meeting SFI Spec 42.1 mandatory. Carbon fiber, Kevlar, and all other composite components (other than the steering wheel) are prohibited in the steering system.

SUSPENSION

Active suspension of any kind prohibited. Any ability to make on-track setting/rate changes based on "real time" data or input from any source, including the shock/strut itself (i.e., magnetically charged fluid), is prohibited. Electrically or pneumatically controlled, hydraulic shocks and/or struts are permitted, provided all adjustment settings/changes are preset before the run. All shocks systems must be NHRA-accepted. Only 1 three-wire shielded cable connection is permitted from the top of the shock/strut to the shock/strut controller. Electrical connections of any other kind to or from the shock/strut prohibited. Shock/strut travel sensors permitted, but may ONLY be connected to the vehicle data recorder. Shock/strut control boxes that have connections for travel sensors must have the pin removed from the connector. Connection to serial port on control box prohibited once car reaches the ready line. All wiring must be visible and easily traceable for technical inspector. Control boxes must be NHRA-accepted. Accepted boxes are the old Koni and the Koni/MSD. Bottom of shock/strut may have a maximum of three air lines connected to an air bottle. Carbon fiber, Kevlar, and all other composite components are prohibited in both the front and rear suspension systems. See General Regulations 3:4.

WHEELIE BARS

Permitted. Wheels must be nonmetallic. See General Regulations 3:6.

FRAME: 4

GROUND CLEARANCE

Minimum 3 inches from front of vehicle to 12 inches behind centerline of front axle, 2 inches for remainder of vehicle, except oil pan and exhaust headers.

PARACHUTE

Mandatory. Dual parachutes required for A/D, A/DA, B/D, B/DA, A/ED, AA/AM, AA/AT, BB/AM, BB/AT, A/A, A/AA, and A/AP. See General Regulations 4:8.

INTERIOR: 6**SHEET METAL**

Driver-compartment interior must be aluminum or steel. Magnesium prohibited.

WINDOW NET

Window net meeting SFI 27.1 mandatory in full-bodied vehicles. See General Regulations 6:3.

UPHOLSTERY

All front-engine open-bodied supercharged or turbocharged (gasoline or methanol) cars, a flame-retardant-material-covered seat mandatory.

BODY: 7**BODY**

All full-bodied altered and econo altered, the maximum front-end overhang for the 1994-1995 Chevrolet Lumina is 47.375 inches, 1994-1997 Pontiac Firebird is 50 inches, 1998-2002 Pontiac Trans Am/Firebird is 46.375 inches, and 1998-2002 Chevrolet Camaro is 46.25 inches. For all other applications, the maximum is 45 inches.

ELECTRICAL: 8**BATTERIES**

See General Regulations 8:1, 8:3, 8:4.

DELAY BOXES/DEVICES

Prohibited. See General Regulations 8:2.

MASTER CUTOFF

Mandatory on all vehicles with a battery. See General Regulations 8:4.

TAILLIGHT

One functional taillight mandatory. See General Regulations 8:6.

SUPPORT GROUP: 9**COMPUTER/DATA RECORDERS**

Permitted. See General Regulations 9:1, 9:2.

FIRE EXTINGUISHER SYSTEM

All front-engine open-bodied supercharged or turbocharged (gasoline or methanol) cars, a fire extinguisher system must meet SFI Spec 17.1. Minimum 20-pound NHRA-accepted fire extinguishing system mandatory. See General Regulations 9:3.

TOW VEHICLES

Permitted. See General Regulations 9:12.

WARM-UPS

See General Regulations 9:5, 9:14.

DRIVER: 10**ARM RESTRAINTS**

Mandatory in open-bodied vehicles. See General Regulations 10:3.

CREDENTIALS

Valid NHRA competition license mandatory. All competitors at NHRA Mello Yello national events must be a minimum of 18 years of age. See General Regulations 10:4.

DRIVER ADDITIONAL EQUIPMENT

Any vehicle that runs quicker than 6.00 seconds must meet all applicable safety requirements for the body style used (i.e., full-bodied vehicles must meet Pro Modified, dragsters must meet Top Alcohol Dragster rules, and altered/Funny Cars must meet Top Alcohol Funny Car rules). Exception: Cars competing in Competition eliminator are not required to have event data recorders or automatic shutoff devices.

DRIVER RESTRAINT SYSTEM

Driver restraint system meeting SFI Spec 16.1 or 16.5 mandatory. Crotch strap mandatory. Restraint system must be updated at two-year intervals from date of manufacture. A minimum six-point driver restraint system installed according to the manufacturer's instructions is required for A/D, A/DA, B/D, B/DA, C/D, C/DA, D/D, H/D, I/D, A/ED, B/ED, C/ED, A/ND, B/ND, AA/AM, AA/AT, BB/A, CC/A, BB/AM, BB/AT, CC/AT, DD/AT, A/A, A/AA, A/AP, B/A, B/AA, B/AP, C/A, C/AA, PST, A/EA, A/PM, AA/PM. Fire-resistant covering on driver restraint system required on all front-engine open-bodied vehicles in AA/AM, AA/AT, BB/A, and BB/AM. See General Regulations 10:5.

HEAD PROTECTOR

Mandatory. See General Regulations 10:6.

HELMET

All front-engine open-bodied supercharged or turbocharged (gasoline or methanol) cars, a full-face Snell SA or SFI equivalent mandatory. All naturally aspirated front-engine open-bodied cars, a full-face Snell SA or SFI equivalent mandatory. Helmet shield mandatory for all open-bodied cars and any closed car running 7.49 seconds or quicker. See General Regulations 10:7.

PROTECTIVE CLOTHING

All front-engine open-bodied supercharged or turbocharged (gasoline or methanol) cars, an SFI 3.3 head sock or an SFI 3.3 skirted helmet, SFI Spec 3.3/15 gloves and boots mandatory.

All naturally aspirated front-engine open-bodied cars, an SFI 3.3 head sock or an SFI 3.3 skirted helmet, SFI Spec 3.3/5 gloves and SFI Spec 3.3/5 boots or shoes mandatory.

All drivers of cars in this class running 7.49 or quicker will be required to wear a jacket and pants or suit meeting SFI Spec 3.2A/15. Refer to specific class section for glove and boots or shoes requirement. See General Regulations 10:10.

SECTION 13A GAS DRAGSTER

Requirements and specifications for Gas Dragster classes are the same as those for Comp - Section 12 - with the following exceptions:

DESIGNATIONS

A/D, A/DA, B/D, B/DA, C/D, C/DA, D/D, D/DA, E/D, E/DA, F/D, F/DA, G/D, G/DA, H/D, I/D, J/D, and J/DA, preceded by the car number.

Classes of competition within Gas Dragster are naturally aspirated dragsters. Class determined by total car weight (including driver) divided by total engine displacement (cubic inches).

CLASSES

- A/D: 3.40 to 3.99 pounds per cubic inch; 1,350-pound minimum; V-8 only
- A/DA: 3.40 to 3.99 pounds per cubic inch; 1,350-pound minimum; V-8 only, automatic transmission with converter only
- B/D: 4.00 to 4.49 pounds per cubic inch; 1,350-pound minimum; V-8 only
- B/DA: 4.00 to 4.99 pounds per cubic inch; 1,350-pound minimum; V-8 only, automatic transmission with converter only
- C/D: 4.50 or more pounds per cubic inch, with true wedge cylinder heads (with inline and parallel valves) only; 1,350-pound minimum; V-8 only
- C/DA: 4.50 or more pounds per cubic inch, with true wedge cylinder heads (with inline and parallel valves) only; 1,350-pound minimum; V-8 only, automatic transmission with converter only
- D/D: 5.00 or more pounds per cubic inch; V-6, V-4 engines only; 1,000-pound minimum
- D/DA: 5.00 or more pounds per cubic inch; 1,000-pound minimum; V-6, V-4 engines only, automatic transmission with converter only
- E/D: 4.50 or more pounds per cubic inch; inline or opposed 5- or 6-cylinder engines
4.40 or more pounds per cubic inch; inline or opposed 5- or 6-cylinder engines with stock production heads
- E/DA: 4.50 or more pounds per cubic inch; inline or opposed 5- or 6-cylinder engines, automatic transmission with converter only
4.40 or more pounds per cubic inch; inline or opposed 5- or 6-cylinder engines with stock production heads, automatic transmission with converter only
- F/D: 7.00 or more pounds per cubic inch; inline 4-cylinder, 2-valve engines only
7.50 or more pounds per cubic inch; for inline 4-valve, 4-cylinder engines only; 850-pound minimum
- F/DA: 7.00 or more pounds per cubic inch; inline 4-cylinder, 2-valve engines only, automatic transmission with converter only
7.50 or more pounds per cubic inch; for inline 4-valve, 4-cylinder engines only, automatic transmission with converter only; 850-pound minimum
- G/D: 8.40 or more pounds per cubic inch; opposed 4-cylinder engines only, 155-cubic-inch maximum as produced; 850-pound minimum
- G/DA: 8.40 or more pounds per cubic inch; opposed 4-cylinder engines only, 155-cubic-inch maximum as produced; automatic transmission with converter only; 850-pound minimum
- H/D: 9.80 or more pounds per cubic inch; 1,800-pound minimum; turbocharged 6- or 8-cylinder, 2- and 4-valve engines only
- I/D: 11.50 or more pounds per cubic inch; 1,500-pound minimum; turbocharged, 4-cylinder, 2- and 4-valve engines only
- J/D: 5.50 or more pounds per cubic inch; inline or opposed 5- or 6- cylinder, 4-valve engines only
- J/DA: 5.50 or more pounds per cubic inch; inline or opposed 5- or 6-cylinder, 4-valve engines only; automatic transmission with converter only

REQUIREMENTS & SPECIFICATIONS**ENGINE: 1****CYLINDER HEADS**

Any type 2-valve head permitted in A/D, A/DA, B/D, B/DA, D/D, D/DA, E/D (see CLASSES), and G/D. Any type 2- or 4-valve head permitted in F/D (see CLASSES), H/D, and I/D. H/D and I/D, billet head prohibited. Any type 4-valve head permitted in J/D. Class C/D and C/DA restricted to true wedge cylinder heads (with inline and parallel valves) only.

ENGINE

Any naturally aspirated, internal-combustion, reciprocating, automotive-type engine permitted. Maximum one engine. See General Regulations 1:2.

FUEL

Methanol accepted in H/D and I/D. All other classes, NHRA-accepted racing gasoline only. Propylene oxide and/or nitrous oxide prohibited. See General Regulations 1:6.

INDUCTION

Electronic fuel injection permitted. Any induction system permitted. See General Regulations 9:1, 9:11.

OIL SYSTEMS

Dry-sump oil systems permitted. Any oil pump configuration permitted; may be combined with other pump functions.

TURBOCHARGER

Permitted in H/D and I/D classes only. H/D limited to 6-cylinder, single turbo applications limited to a maximum 91mm; 6-cylinder, twin turbo applications limited to a maximum 76mm; 8-cylinder, small-block twin turbo applications limited to a maximum 78mm; 8-cylinder, big-block twin turbo applications limited to a maximum 82mm. I/D limited to maximum single 76mm turbocharger only (twin turbos prohibited).

VENT TUBE BREATHERS

Mandatory. See General Regulations 1:13.

DRIVETRAIN: 2**CLUTCH, FLYWHEEL, FLYWHEEL SHIELD**

Flywheel and clutch meeting SFI Spec 1.1, 1.2, 1.3, or 1.4 mandatory. Flywheel shield meeting SFI Spec 6.2 or 6.3 mandatory on all cars using SFI Spec 1.2 clutch (three or more discs) or SFI Spec 1.3 or 1.4 clutches (two discs max). Flywheel shield meeting SFI Spec 6.2 mandatory with SFI Spec 1.3 or 1.4 clutch using three or more discs. Flywheel shield meeting minimum SFI Spec 6.1-mandatory on all other cars. Multi-stage lockup-type clutch prohibited. Clutch release must be manually operated by driver's foot: Electronics, pneumatics, hydraulics, or any other device may in no way affect the clutch operation. NHRA-accepted physically challenged hand controls permitted. See General Regulations 2:3, 2:5, 2:6, 2:9.

DRIVELINE

Anti-blowback device mandatory in Classes A/D, B/D, C/D, and D/D. See General Regulations 2:1, 2:4.

TRANSMISSION, AUTOMATIC

Permitted in A/DA, B/DA, C/DA, D/DA, E/DA, F/DA, G/DA, H/D, I/D, and J/DA. See Section 12, Transmission, Automatic, for details.

TRANSMISSION, MANUAL

Permitted in A/D, B/D, C/D, D/D, E/D, F/D, G/D, H/D, I/D, and J/D. See Section 12, Transmission, Manual, for details.

BRAKES & SUSPENSION: 3**BRAKES**

Two rear-wheel hydraulic brakes mandatory. Hand brake, if used, must be located inside roll cage. Steel brake lines mandatory. All brake lines passing engine on any rear-engine car must be shielded. See General Regulations 3:1.

SUSPENSION

Any automotive suspension permitted. Rigid-mounted rear axles permitted. Rigid-mounted front axles permitted if wheelbase is 120 inches or more. Any front suspension using a beam or tubular axle must have radius rods attached to frame. Radius rods not mandatory on front axles rigidly mounted 18 inches or less from kingpin axis. See General Regulations 3:4.

FRAME: 4**BALLAST**

Permitted. See General Regulations 4:2.

DEFLECTOR PLATE

Must be installed between roll cage and engine on all rear-engine cars to protect driver and fuel tank. Minimum material thickness: .125-inch aluminum or .060-inch steel. See General Regulations 4:3.

PINION SUPPORT

Mandatory on all front-engine cars. See General Regulations 4:9.

ROLL CAGE

Mandatory. A/D, B/D, C/D, D/D, A/DA, B/DA, C/DA, D/DA, H/D, and I/D must conform to SFI Spec 2.5 (rear engine) or 2.4 (front engine); all other vehicles must conform to SFI Spec 2.7 (rear engine) or 2.6 (front engine). (Rear-end-mounting and wing-support portions do not apply.) See General Regulations 4:4, 4:11, 10:6.

ROLL-CAGE PADDING

Roll-cage padding meeting SFI Spec 45.1 mandatory anywhere driver's helmet may come in contact with roll-cage components. See General Regulations 4:11.

WHEELBASE & TREAD WIDTH

Minimum 90 inches. Maximum wheelbase variation from left to right: 2 inches. Minimum front tread width: 26 inches.

TIRES & WHEELS: 5**TIRES**

Minimum diameter of 13 inches on front tires. See General Regulations 5:1.

WHEELS

Automotive-type wire wheels permitted on front axle only, provided total weight of car does not exceed 1,800 pounds, excluding driver. See General Regulations 5:2.

INTERIOR: 6**UPHOLSTERY**

Optional.

BODY: 7**AIRFOIL**

Side-mounted canard-type units permitted, must be securely mounted. Mandatory on front-engine cars in A/D, B/D, C/D, D/D, A/DA, B/DA, C/DA, D/DA, H/D, and I/D without a rear wing. Minimum 175 square inches per side; maximum of 350 square

inches per side; may not extend more than 1 inch outside rear tires. No part of canards/wings may be within 6 inches of rear tire. Frontal air dam permitted. Maximum projection ahead of spindle centerline: 30 inches. Width cannot exceed front tread width. Maximum rise: 10 inches. Projection behind front axle, outside of framerrails prohibited. Spill plates permitted, not to exceed 9 inches in height. Ground clearance must be 3 inches. Rear wing mandatory on rear-engine cars or front-engine cars without side-mounted canards in A/D, A/DA, B/D, B/DA, C/D, C/DA, D/D, D/DA, H/D, and I/D; minimum area 350 square inches, maximum 750 square inches, minimum height 55 inches (measured vertically from trailing edge to ground). Spill plates must be flat/straight and parallel and measure a minimum of 50 square inches each. Leading edge of wing may be no more than 10 inches maximum from centerline of rear axle. Wing may not be configured or installed so as to generate negative downforce or lift. Any adjustment or movement during run prohibited. Front-engine cars utilizing a rear wing must have wing attached directly to roll cage (i.e., no wing struts). See General Regulations 7:1.

BODY

Body and cowl must be metal, fiberglass, or carbon fiber and must extend forward to firewall. Driver compartment, frame structure, roll bars, and body must be designed to prevent driver's body or limbs from contact with wheels, tires, exhaust system, or track surface. If driver's body is in contact with belly pan, a crossmember and subfloor are mandatory. Altered-type bodies prohibited. Driver's legs must be retained inside frame by subflooring or other retaining device that is independent of car's body. On open-wheel, front-engine cars, hood scoop may not extend more than 11 inches above height of carburetor top.

FRONT-WHEEL FAIRINGS

Prohibited.

WINDSCREEN

Mandatory. See General Regulations 7:7.

ELECTRICAL: 8

IGNITION

See General Regulations 8:1, 8:3, 8:4, 8:5.

SUPPORT GROUP: 9

FIRE EXTINGUISHER SYSTEM

Permitted. See General Regulations 9:3.

DRIVER: 10

DRIVER

Any location permitted if in compliance with General Regulations. Any car with no crossmember above driver's legs must have a strap or device to prevent legs from projecting outside chassis.

HELMET

For all turbocharged and/or methanol-burning cars, a full-face Snell SA2010 helmet and shield mandatory (goggles prohibited). For all naturally aspirated gasoline-burning cars, a full-face Snell M2010, M2015, SA2010, or SA2015 helmet and shield mandatory (goggles prohibited). See General Regulations 10:7.

NECK COLLAR/HEAD AND NECK RESTRAINT DEVICE/SYSTEM

Head and neck restraint device/system meeting SFI 38.1 mandatory in A/D, A/DA, B/D, B/DA, C/D, C/DA, D/D, D/DA, E/D, E/DA, J/D, J/DA, H/D, and I/D. Neck collar meeting

SFI Spec 3.3 mandatory in all other classes. See General Regulations 10:8.

PROTECTIVE CLOTHING

Jacket and pants meeting SFI Spec 3.2A/5 and gloves meeting SFI Spec 3.3/1 mandatory, except cars running 7.49 or quicker, jacket and pants or suit meeting SFI Spec 3.2A/15, gloves meeting SFI Spec 3.3/5, and boots or shoes meeting SFI Spec 3.3/5 mandatory. A suit meeting SFI Spec 3.2A/15, gloves meeting SFI Spec 3.3/5, and boots or shoes meeting SFI Spec 3.3/5 mandatory when automatic transmission is located in driver compartment. H/D and I/D require a driver's suit meeting SFI Spec 3.2A/15 with SFI Spec 3.3/15 gloves and SFI Spec 3.3/15 boots. Drivers of all front-engine cars required to have an SFI 3.3 head sock or an SFI 3.3 skirted helmet. All drivers who do not use an SFI 3.3 neck collar (drivers who use head and neck restraint system only), an SFI 3.3 head sock or SFI 3.3 skirted helmet mandatory. See General Regulations 10:10.

SECTION 13B ECONO DRAGSTER

Requirements and specifications for Econo Dragster classes are the same as those for Comp - Section 12 - with the following exceptions:

DESIGNATIONS

A/ED, B/ED, C/ED, D/ED, E/ED, F/ED, and G/ED, preceded by car number.

Classes of competition within Econo Dragster are for naturally aspirated, single-engine gas dragsters. Class determined by total car weight (including driver) divided by total engine displacement (cubic inches).

CLASSES

- A/ED - 3.40 or more pounds per cubic inch; 1,350-pound minimum; V-8 only.
- B/ED - 4.00 to 4.99 pounds per cubic inch; 1,350-pound minimum; V-8 only.
- C/ED - 5.00 or more pounds per cubic inch; 1,350-pound minimum; V-8 only.
- D/ED - 5.00 or more pounds per cubic inch, V-6 engines only; 1,150-pound minimum.
- E/ED - 6.00 or more pounds per cubic inch. Inline or opposed 6-cylinder engines, 2-valve only; 1,150-pound minimum.
- F/ED - 6.25 or more pounds per cubic inch. Inline 4-cylinder engines only. Two valves per cylinder maximum; 950-pound minimum.
- G/ED - 6.00 or more pounds per cubic inch. Inline or opposed 6-cylinder engines, 4-valve only; 1,150-pound minimum.

REQUIREMENTS & SPECIFICATIONS

ENGINE: 1

CARBURETORS

A/ED and B/ED: one NHRA-accepted OEM-type 4-barrel. C/ED: one NHRA-accepted OEM-type 4-barrel, 750cfm maximum, throttle bore restricted to manufacturer's dimension, venturi restricted to manufacturer's dimension plus .025-inch measured at largest point. D/ED, E/ED, F/ED, and G/ED: any standard

OEM carburetor(s) permitted. Carburetor manufacturer must be represented in NHRA Blueprint Bulletins. Weber or Weber-type carburetor restricted to 55mm Weber or equivalent.

C/ED through G/ED: minimum throttle-shaft-diameter .085-inch, measured at thinnest point, minimum throttle plate thickness .040-inch, measured at thinnest point. Prohibited in all classes: cutting and reassembling, inline multibarrel (i.e., more than two) configuration, slide valve carburetors, motorcycle carburetors, fuel injection. Throttle-bore modifications prohibited in all classes except A/ED.

CYLINDER HEADS

All heads must be NHRA-accepted, two valves per cylinder, OEM casting (no billet) except as noted in G/ED. Heads must have OEM number cast into head. A/ED: hemi, canted/splayed valve, or wedge head permitted. B/ED and C/ED: true wedge cylinder heads (with inline and parallel valves) only. Porting, polishing permitted; header plates permitted. Exhaust port plates that protrude into port prohibited. Any size valves permitted, valves may be tilted and/or canted. Angle milling and/or rolling permitted. External modifications permitted. Combustion-chamber modifications permitted. The valve cover rail may be modified. Heads may be cut for larger pushrods and springs. Spark plug holes must be in NHRA-approved location. Siamese-configured cylinder heads are prohibited in E/ED and G/ED.

ENGINE

One OEM or NHRA-accepted aftermarket, naturally aspirated, automobile engine permitted. B/ED: maximum 366 cid. OEM bore center spacing mandatory. See General Regulations 1:2.

FUEL

NHRA-accepted racing gasoline only. Propylene oxide and/or nitrous oxide prohibited. See General Regulations 1:6.

SPARK PLUGS

The use of angle-tipped spark plugs is prohibited.

OIL SYSTEMS

Dry-sump oil systems prohibited. External single-stage oil pumps permitted; additional pump stages are limited to non-oil-pump functions such as vacuum pump, water pumps, etc.

DRIVETRAIN: 2

DRIVELINE

See General Regulations 2:4.

TRANSMISSION, AUTOMATIC

Permitted. See Section 12, Transmission, Automatic, for details.

TRANSMISSION, MANUAL

Prohibited.

BRAKES & SUSPENSION: 3

BRAKES

Two rear-wheel hydraulic brakes mandatory. Hand brake, if used, must be located inside roll cage. Steel brake lines mandatory. All brake lines passing engine on any rear-engine car must be shielded. See General Regulations 3:1.

SUSPENSION

Any automotive-type suspension permitted. Rigid-mounted rear axles permitted. Rigid-mounted front axles permitted if wheelbase is 120 inches or more. Any front suspension using a beam or tubular axle must have radius rods attached to frame. Radius rods not mandatory on front axles rigidly mounted 18 inches or less from kingpin axis. See General Regulations 3:4.

FRAME: 4**BALLAST**

Permitted. See General Regulations 4:2.

DEFLECTOR PLATE

Must be installed between roll cage and engine on all rear-engine cars to protect driver and fuel tank. Minimum material thickness: .125-inch aluminum or .060-inch steel. See General Regulations 4:3.

PINION SUPPORT

Mandatory on all front-engine cars. See General Regulations 4:9.

ROLL CAGE

Mandatory. A/ED, B/ED, C/ED, D/ED must conform to SFI Spec 2.5 (rear engine) or 2.4 (front engine); all other vehicles must conform to SFI Spec 2.7 (rear engine) or 2.6 (front engine). See General Regulations 4:4, 4:11, 10:6.

ROLL-CAGE PADDING

Roll-cage padding meeting SFI Spec 45.1 mandatory anywhere driver's helmet may come in contact with roll-cage components. See General Regulations 4:11.

WHEELBASE & TREAD WIDTH

Minimum 90 inches. Maximum wheelbase variation from left to right: 2 inches. Minimum front tread width: 26 inches.

TIRES & WHEELS: 5**TIRES**

Minimum diameter of 13 inches on front tires. See General Regulations 5:1.

WHEELS

Lightweight automotive-type wire wheels permitted on front axle only, provided total car weight does not exceed 1,800 pounds, excluding driver. See General Regulations 5:2.

INTERIOR: 6**UPHOLSTERY**

Optional.

BODY: 7**AIRFOIL**

Side-mounted canard-type units permitted, must be securely mounted. Mandatory on front-engine cars in A/ED, B/ED, C/ED, and D/ED without a rear wing. Minimum 175 square inches per side; maximum 350 square inches per side; may not extend more than 1 inch outside rear tires. No part of wings/canards may be within 6 inches of rear tire. Frontal air dam permitted. Maximum projection ahead of spindle centerline: 30 inches. Width cannot exceed front tread width. Maximum rise: 10 inches. Projection behind front axle, outside framereails, prohibited. Spill plates permitted, not to exceed 9 inches in height. Ground clearance must be 3 inches. Any adjustment or movement during run prohibited. Rear wing mandatory on rear-engine cars and front-engine cars without side-mounted canards in A/ED, B/ED, C/ED, and D/ED; minimum area 350 square inches, maximum 750 square inches, minimum height 55 inches (measured vertically from trailing edge to ground). Spill plates must be flat/straight and parallel and measure a minimum of 50 square inches each. Leading edge of wing may be no more than 10 inches maximum from centerline of rear axle. Wing may not be configured or installed so as to generate

negative downforce or lift. Any adjustment or movement during run prohibited. Front-engine cars utilizing a rear wing must have wing attached directly to roll cage (i.e., no wing struts). See General Regulations 7:1.

BODY

Body and cowl must be metal, fiberglass, or carbon fiber and extend forward to firewall. Driver compartment, frame structure, roll bars, and body must be designed to prevent driver's body or limbs from making contact with wheels, tires, exhaust system, or track surface. If driver's body is in contact with belly pan, crossmember and subfloor mandatory. Altered-type bodies prohibited. Driver's legs must be retained inside frame by subflooring or other retaining device that is independent of car's body. On open-bodied, front-engine cars, hood-scoop opening may not extend more than 11 inches above height of carburetor top.

FRONT-WHEEL FAIRINGS

Prohibited.

WINDSCREEN

Mandatory. See General Regulations 7:7.

ELECTRICAL: 8**IGNITION**

See General Regulations 8:1, 8:3, 8:4, 8:5.

SUPPORT GROUP: 9**FIRE EXTINGUISHER SYSTEM**

Permitted. See General Regulations 9:3.

DRIVER: 10**DRIVER**

Any location permitted if in compliance with General Regulations. Any car with no crossmember above driver's legs must have a strap or device to prevent legs from projecting outside chassis.

HELMET

For all cars, a full-face Snell M2010, M2015, SA2010, or SA2015 helmet and shield mandatory (goggles prohibited). See General Regulations 10:7.

NECK COLLAR/HEAD AND NECK RESTRAINT DEVICE/SYSTEM

Head and neck restraint device/system meeting SFI 38.1 mandatory in A/ED, B/ED, C/ED, and D/ED. Neck collar meeting SFI Spec 3.3 mandatory in all other classes. See General Regulations 10:8.

PROTECTIVE CLOTHING

Jacket and pants meeting SFI Spec 3.2A/5 and gloves meeting SFI Spec 3.3/1 mandatory, except cars running 7.49 or quicker, jacket and pants or suit meeting SFI Spec 3.2A/15, gloves meeting SFI Spec 3.3/5, and boots or shoes meeting SFI Spec 3.3/5 mandatory. A suit meeting SFI Spec 3.2A/15, gloves meeting SFI Spec 3.3/5, and boots or shoes meeting SFI Spec 3.3/5 mandatory when automatic transmission is located in driver compartment. Drivers of all front-engine cars required to have an SFI 3.3 head sock or an SFI 3.3 skirted helmet. All drivers who do not use an SFI 3.3 neck collar (drivers who use head and neck restraint system only), an SFI 3.3 head sock or SFI 3.3 skirted helmet mandatory. See General Regulations 10:10.

SECTION 13C

NOSTALGIA DRAGSTER

Requirements and specifications for Nostalgia Dragster classes are the same as those for Comp - Section 12 - with the following exceptions:

DESIGNATION

A/ND, preceded by car number.

Class of competition within Nostalgia Dragster is for front-engine, methanol-burning dragsters.

CLASSES

A/ND - 3.50 pounds per cubic inch, 1,300 pounds minimum weight.

B/ND - 3.50 pounds per cubic inch, 1,300 pounds minimum weight. Limited to OEM cast-iron Hemi, 23-degree Chevy, or OEM Ford cylinder head.

REQUIREMENTS & SPECIFICATIONS

ENGINE: 1

CYLINDER HEAD

For B/ND, cylinder head must be NHRA accepted; valves may be tilted +/- maximum 3 degrees by angle milling the cylinder head only.

ENGINE

One internal-combustion, reciprocating, automobile-type engine permitted. Cast-iron block mandatory. Aluminum heads prohibited. Maximum 430 cid. No collector-style headers allowed. Dry sumps and evacuation system permitted. See General Regulations 1:2.

EXHAUST SYSTEM

Collector-style headers prohibited. See General Regulations 1:3.

FUEL

Methanol or NHRA-accepted racing gasoline mandatory. Propylene oxide and/or nitrous oxide prohibited. See General Regulations 1:6.

FUEL SYSTEM

Maximum one fuel pump. Mechanical fuel injection, with individual stacks and cast manifold only, or NHRA accepted, mandatory. A/ND, round injector maximum diameter is 3.150 inches (as measured across the butterfly shaft); rotary injector (i.e., with no butterflies) permitted, oval, rectangular, and siamesed (two cylinders/ports maximum) injectors also permitted; area may not exceed that of a 3.150-inch diameter per port. B/ND, round injector with butterflies required; 2.875-inch diameter maximum as measured across the butterfly shaft. Down nozzles prohibited. See General Regulations 1:5.

DRIVETRAIN: 2

DRIVELINE

See General Regulations 2:4.

TRANSMISSION, AUTOMATIC

Permitted. Maximum two forward speeds. Automated, electric, or pneumatic shifter prohibited. See Section 12, Transmission, Automatic, for details.

TRANSMISSION, MANUAL

Prohibited.

BRAKES & SUSPENSION: 3**BRAKES**

Two rear-wheel hydraulic disc brakes mandatory. Hand brake, if used, must be located inside roll cage. See General Regulations 3:1.

SUSPENSION

Any automotive type suspension permitted. Rigid-mounted rear axles permitted. Rigid-mounted front axles permitted if wheelbase is 120 inches or more. Any front suspension using a beam or tubular axle must have radius rods attached to frame. Radius rods not mandatory on front axles rigidly mounted 18 inches or less from kingpin axis. See General Regulations 3:4.

FRAME: 4**BALLAST**

Permitted. See General Regulations 4:2.

PINION SUPPORT

Mandatory. See General Regulations 4:9.

ROLL CAGE

Mandatory. Chassis must conform to SFI Spec 2.4. See General Regulations 4:4, 4:11, 10:6.

ROLL-CAGE PADDING

Roll-cage padding meeting SFI Spec 45.1 mandatory anywhere driver's helmet may come in contact with roll-cage components. See General Regulations 4:11.

WHEELBASE & TREAD WIDTH

Minimum wheelbase 90 inches, maximum 225 inches. Maximum wheelbase variation from left to right: 2 inches. Minimum front tread width: 26 inches.

TIRES & WHEELS: 5**TIRES**

Maximum width 12 inches as measured across tread surface or indicated by manufacturer on the sidewall. See General Regulations 5:1.

WHEELS

Lightweight automotive-type wire wheels permitted on front axle only, provided total car weight does not exceed 1,800 pounds, excluding driver. Maximum rear wheel width 12 inches. See General Regulations 5:2.

BODY: 7**AIRFOIL**

Side-mounted canard-type units permitted, maximum 400 square inches per side. Maximum front overhang 30 inches. Ground clearance must be 3 inches. See General Regulations 7:1.

BODY

Body and cowl must be metal, fiberglass, or carbon fiber and extend forward to firewall. Driver compartment, frame structure, roll bars, and body must be designed to prevent driver's body or limbs from making contact with wheels, tires, exhaust system, or track surface. If driver's body is in contact with belly pan, crossmember and subfloor mandatory. Altered-type bodies prohibited. Driver's legs must be retained inside frame by subflooring or other retaining device that is independent of car's body.

FRONT-WHEEL FAIRINGS

Prohibited.

WINDSCREEN

Mandatory. See General Regulations 7:7.

ELECTRICAL: 8**IGNITION**

Single magneto or single coil ignition only. See General Regulations 8:1, 8:3, 8:4, 8:5.

SUPPORT GROUP: 9**FIRE EXTINGUISHER SYSTEM**

Minimum 5-pound, NHRA-accepted fire extinguishing system mandatory. See General Regulations 9:3.

DRIVER: 10**DRIVER**

Any car with no crossmember above driver's legs must have a strap or device to prevent legs from projecting outside chassis.

HELMET

For all cars, a full-face Snell SA2010, or SA2015 helmet and shield mandatory (goggles prohibited). See General Regulations 10:7.

NECK COLLAR/HEAD AND NECK RESTRAINT DEVICE/SYSTEM

Head and neck restraint device/system meeting SFI 38.1 mandatory in A/ND and B/ND. Neck collar meeting SFI Spec 3.3 mandatory in all other classes. See General Regulations 10:8.

PROTECTIVE CLOTHING

Jacket and pants meeting SFI Spec 3.2A/15, gloves 3.3/15, and boots/shoes 3.3/15 mandatory. Drivers of all cars required to have an SFI 3.3 head sock or an SFI 3.3 skirted helmet. See General Regulations 10:10.

SECTION 13D ALTERED & STREET ROADSTER

Requirements and specifications for Altered & Street Roadster classes are the same as those for Comp - Section 12 - with the following exceptions:

DESIGNATIONS

AA/AM, AA/AT, BB/A, CC/A, BB/AM, BB/AT, CC/AT, DD/AT, A/A, A/AP, B/A, B/AP, C/A, D/A, E/A, F/A, G/A, H/A, I/A, J/A, K/A, L/A, A/AA, B/AA, C/AA, D/AA, E/AA, F/AA, G/AA, H/AA, I/AA, J/AA, K/AA, L/AA, AA/AF, and BB/AF, preceded by car number.

Class determined by total car weight (including driver) divided by total cubic inches of engine displacement.

CLASSES

- AA/AM: 5.40 or more pounds per cubic inch. Supercharged; 450-cubic-inch maximum, methanol; 1,500-pound minimum
- AA/AT: 5.90 or more pounds per cubic inch. Turbocharged; V-8 only; 1,500-pound minimum
- BB/A: 7.50 or more pounds per cubic inch. Supercharged; 2,100-pound minimum. 4-cylinder; 1,350-pound minimum



NO TORCH!
IT IS VERY DANGEROUS
AND AGAINST THE RULES



**NOT ONE
SIZE FITS
ALL**

From the 70# Mother Bottle to the small 2#
Bottle and all sizes in-between we have the
CORRECT size WARMER for YOUR Bottle



www.archeat.com

TEL: 877-ARC-HEAT

FAX: 386-760-0721

BECOME A MEMBER!



NATIONAL DRAGSTER

- * 24 issues of *NHRA National Dragster*
- * Access to Membership Hospitality Center at every NHRA Mello Yello Drag Race
- * 25% off NHRA All Access livestreaming service
- * \$10 off up to four tickets to NHRA Mello Yello Drag Racing events
- * 10% off NHRA merchandise from NitroMall and NitroMall.com
- * 10% off Dragmart classified ads in *NHRA National Dragster*
- * Digital edition of NHRA Rulebook and *NHRA National Dragster*
- * Official NHRA membership card, collector's pin, and decal
- * Free admission to Wally Parks NHRA Motorsports Museum
- * \$575,000 Excess Medical Insurance

**Become a Member for just \$69 per year,
or save when you choose 2 or 3 years.**

BECOME A MEMBER || NHRA.com || 800.308.NHRA

POWER DELIVERED BY

INLAND EMPIRE DRIVELINE

"For Driveshafts That Make A Difference"

800.800.0109

FAST – EASY – CORRECT – RELIABLE

4035 E. Guasti Road, Suite 301
Ontario, CA 91761

www.iedls.com
tech@iedls.com



- 36 YEARS EXPERIENCE
- 3 MEASUREMENTS NEEDED
- ONE PHONE CALL
- PROMPT SHIPPING
- GUARANTEED TO FIT
- AFFORDABLE PRICING
- SFI 41.3 COMPLIANT
- UNEQUALED RECORD OF SUCCESSFUL LAUNCHES AND SMOOTH RIDES
- MADE IN THE USA

Call Jeff or Rocky at

800-800-0109

What can we do for you?

Find us on 

Facebook.com/InlandEmpireDriveLineService



**WATCH THE NHRA
MELLO YELLO DRAG
RACING SERIES**

**SPEED INTO YOUR
LIVING ROOM ALL
SEASON LONG**

THE FASTEST, MOST EXPLOSIVE SPORT IN THE WORLD!



NHRA.COM/TV

SPEED FOR ALL

- CC/A: 8.00 or more pounds per cubic inch. One centrifugal supercharger only. Full-bodied cars only. 2,700-pound minimum
- BB/AM: 7.50 or more pounds per cubic inch. Supercharged; small-block only; methanol. 1,500-pound minimum
- BB/AT: 8.20 or more pounds per cubic inch. Turbocharged; 2,100-pound minimum. 4-cylinder; 1,350-pound minimum
- CC/AT: 13.40 or more pounds per cubic inch. Turbocharged; 6-cylinder, 4-valve engines only; 2,450-pound minimum. Full-bodied cars only
- DD/AT: 16.40 or more pounds per cubic inch. Turbocharged; 4-cylinder, 4-valve engines; 2,000-pound minimum. Full-bodied cars only
- A/A: 3.40 to 5.39 pounds per cubic inch; 1,500-pound minimum
- A/AP: 3.40 to 5.39 pounds per cubic inch. Planetary-type transmission with torque converter; 1,500-pound minimum
- B/A: 5.40 to 6.49 pounds per cubic inch; 1,500-pound minimum
- B/AP: 5.40 to 6.49 pounds per cubic inch. Planetary-type transmission with torque converter; 1,500-pound minimum
- C/A: 6.50 to 7.49 pounds per cubic inch; 2,100-pound minimum
- D/A: 7.50 to 8.49 pounds per cubic inch. 2,100-pound minimum
- E/A: 7.50 to 8.49 pounds per cubic inch. True wedge cylinder heads (with inline and parallel valves) only; 2,100-pound minimum
- F/A: 8.50 to 9.49 pounds per cubic inch; 2,100-pound minimum
- G/A: 9.50 to 10.49 pounds per cubic inch; 2,100-pound minimum
- H/A: 10.50 to 11.49 pounds per cubic inch; 2,100-pound minimum (A/Altered through H/Altered are V-8-only classes)
- I/A: 8.50 or more pounds per cubic inch. V-6, V-4 engines only; 2,000-pound minimum
- J/A: 5.50 or more pounds per cubic inch. Inline or opposed 5- or 6-cylinder engines only; 1,400-pound minimum
- K/A: 5.50 or more pounds per cubic inch. Inline 4-cylinder, 2-valve engines only; 1,100-pound minimum
- L/A: 10.00 or more pounds per cubic inch. Inline 4-cylinder, 2-valve engines; 1,600-pound minimum
10.50 or more pounds per cubic inch. Inline 4-cylinder, 4-valve engines; 1,600-pound minimum
- AA/AF: Maximum 153 cubic inches; turbocharged, 4-cylinder, 4-valve only. Front-wheel drive only, full-tube chassis permitted. Minimum weight: GM Ecotec, 2,050 pounds, all others 1,750 pounds. Competitors may use engines up to 176 cubic inches maximum but must add 16 pounds per cubic inch to the minimum weight for each cubic inch over 153
- BB/AF: Maximum 153 cubic inches; turbocharged, 4-cylinder, 4-valve only. Front-wheel drive only, full-tube chassis prohibited. Minimum weight: GM Ecotec, 2,350 pounds, all others, 2,050 pounds. Competitors may use engines up to 158 cubic inches maximum but must add 16 pounds per cubic inch to the minimum weight for each cubic inch over 153

Classes A/A through L/A are manual transmission only. Classes

A/AA through L/AA are automatic transmission only, utilize corresponding manual-transmission class displacements and minimum weights. A/AP and B/AP reserved for planetary-type transmission with torque converter.

DESIGNATIONS

A/SR, B/SR, and C/SR, preceded by car number.

Three classes of competition for naturally aspirated Street Roadsters. Class determined by total car weight (including driver) divided by total cubic inches of engine displacement.

CLASSES

- A/SR: 7.00 or more pounds per cubic inch. Manual transmission only, V-8 only; 2,100-pound minimum
- B/SR: 6.40 or more pounds per cubic inch. Fully automatic transmission and converter; V-8 only, 1,900-pound minimum
- C/SR: 8.00 or more pounds per cubic inch. Fully automatic transmission and converter; V-6 only; 2,000-pound minimum

REQUIREMENTS & SPECIFICATIONS

ENGINE: 1

CARBURETOR, STREET ROADSTERS

One NHRA-accepted 4-barrel, maximum 750cfm, standard OEM configuration mandatory. Throttle bore restricted to manufacturer's dimension, measured at largest point, venturi restricted to manufacturer's dimension plus .025-inch, measured at largest point. Minimum throttle-shaft diameter .085-inch, measured at thinnest point. All classes, minimum throttle-plate thickness .040-inch, measured at thinnest point. The following are prohibited: throttle-bore modifications, cutting and reconfiguring, inline multibarrel (i.e., more than two) configuration, slide valve carburetors, motorcycle carburetors, fuel injection.

CYLINDER HEADS, ALTEREDS

Any type 2-valve head permitted in A through D, F through H, J, A/AP, B/AP, and CC/A. E is restricted to true wedge cylinder heads (with inline and parallel valves) only. I, K, and L are restricted to OEM generally available, NHRA-accepted heads. I and K are also restricted to 2-valve cylinder heads; L may be 2-valve or 4-valve. CC/AT and DD/AT are restricted to 4-valve cylinder heads only. AA/AF and BB/AF are restricted to OEM production (assembly line) 4-valve cast cylinder heads only. For all other classes, any cylinder-head configuration is permitted.

CYLINDER HEADS, STREET ROADSTERS

All heads must be NHRA-accepted, two valves per cylinder, OEM casting (no billet) with OEM number cast into head. Hemi, canted/splayed valve, or wedge head permitted. Porting, polishing permitted; header plates permitted. Exhaust port plates that protrude into port prohibited. Any size valves permitted, valves may be tilted and/or canted. Angle milling and/or rolling permitted. External modifications permitted in port area. Combustion-chamber modifications permitted. The valve cover rail may be modified. Heads may be cut for larger pushrods and springs. Spark plug holes must be in NHRA-approved location.

ENGINE

One internal-combustion, reciprocating, automobile-type engine permitted. OEM bore center spacing mandatory in Street Roadster. Any engine setback permitted. All classes naturally aspirated except AA/AM, AA/AT, BB/A, BB/AM, BB/AT, CC/AT, DD/AT, AA/AF, and BB/AF. Classes A/A through H/A, V-8

engines only permitted. Classes AA/AF and BB/AF limited to OEM production block. AA/AF, transverse or longitudinal engine orientation permitted. BB/AF must retain transverse engine orientation. See General Regulations 1:2.

FUEL

NHRA-accepted racing gasoline only. Methanol mandatory in AA/AM and BB/AM. Methanol permitted in AA/AF, BB/AF, AA/AT, BB/AT, CC/AT, and DD/AT. Propylene oxide and/or nitrous oxide prohibited. See General Regulations 1:6.

SPARK PLUGS

The use of angle-tipped spark plugs is prohibited in all street roadster classes, permitted in all altered classes.

INDUCTION, ALTEREDS

Electronic fuel injection permitted. Any induction permitted. See General Regulations 9:1, 9:11.

NITROUS OXIDE

Prohibited.

OIL SYSTEMS

Dry-sump oil systems permitted in Altered classes, prohibited in Street Roadster. Any oil-pump configuration permitted in Altered classes, may be combined with other pump functions. Street Roadster classes, single stage external pump only permitted; additional pump stages are limited to non-oil-pump functions such as vacuum pumps, water pumps, etc.

SUPERCHARGER

Restricted to Roots-type supercharger, rotor helix angle not to exceed that of standard 71-series GM-type rotor. Maximum size: 14-71, 22 1/4-inch case length, 11 1/4-inch case width, 19-inch rotor length; maximum rotor diameter: 5.840 inches including fixed stripping. The case must be one piece with removable front and rear bearing end plates; rotor must be contained within one-piece case. The rotors must be driven from the front (both the external drive and the internal gearing). The entire inlet opening must be on/in the upper surface only. Any inlet/outlet cavity in front of the rotors is restricted to maximum 2.150 inches, measuring from the face of bearing plate to the back of the cavity. Billet cases prohibited. The maximum length from the front of the supercharger drive pulley to the leading edge of the rotor is 15 inches. Offset drive pulleys may not be used to add to the number listed above. All manifold configurations and supercharger modifications and locations must be accepted prior to competition. Variable multispeed supercharger devices prohibited. All AA/AM, BB/A, and BB/AM vehicles using 12-71 or 14-71 superchargers must have an SFI 14.2 or 14.3 Supercharger Restraint with approved bag from same manufacturer. All other superchargers require an SFI 14.1, 14.2 or 14.3 Supercharger Restraint. Air-to-air intercooler permitted on supercharged vehicles. Supercharger must be in conventional location above the intake manifold and cylinder heads, and supercharger restraint device may not be modified. Ambient air only; i.e., the flow of ambient air through the intercooler and any associated ducting must be only a result of the movement of the vehicle. For CC/A only, a 5.150-inch centrifugal supercharger limited to inlet diameter internal O.D. 5.250 maximum; impeller inducer diameter 5.150-inch maximum; impeller exducer diameter 8.000-inch maximum; discharge diameter 4.000-inch maximum; housing diameter (external diameter of housing not to include discharge) 12.000-inch maximum. Supercharger drive must be belt, NHRA-accepted chain drive or NHRA-accepted gear drive. Aftermarket intercooler permitted (air-to-air or air-to-water/ice). Maximum 3-gallon-capacity reservoir permitted, must be constructed of steel or aluminum, or an SFI 28.1 fuel cell. See General Regulations 1:10, 1:11.

TURBOCHARGER

Air-to-air or water-to-air intercooler permitted on turbocharged vehicles. Maximum one supercharger or two turbochargers (not both). CC/AT: Single turbocharger limited to 74mm; twin turbocharger limited to 58mm. DD/AT: Single turbocharger limited to 76mm; twin turbocharger prohibited on 4-cylinder applications. BB/AF: Ecotec engine limited to single 68mm turbo; all others limited to single 74mm turbo.

DRIVETRAIN: 2**CLUTCH, FLYWHEEL, FLYWHEEL SHIELD**

Flywheel and clutch meeting SFI Spec 1.1, 1.2, 1.3, or 1.4 mandatory. Flywheel shield meeting SFI Spec 6.2 or 6.3 mandatory on all supercharged or turbocharged cars, or any car using a SFI Spec 1.2 clutch (3 or more discs) or an SFI Spec 1.3 or 1.4 clutch (2 discs max). For AA/AF and BB/AF applications where an SFI 6.1, 6.2, or 6.3 flywheel shield is not available, a shield made of ¼-inch-minimum-thickness steel plate is permitted. Shield must surround the flywheel/clutch/bellhousing completely except for area of flywheel shield adjacent to differential and axle shaft. Shield may be multipiece, with pieces securely bolted together using minimum 3/8-inch-diameter Grade 5 or M10 class 8.8 bolts and nuts; must be attached to engine and/or OEM bellhousing with a full complement (all available engine bolt holes) and be equipped with a full motor plate constructed of 1/8-inch-thick steel or 6061-T6, 7075-T6, or 2024-T3 aluminum alloy plate with at least four additional 3/8-inch-diameter Grade 5 or M10 class 8.8 bolts and nuts attaching the lower half of the flywheel shield flange to the motor plate with a maximum bolt spacing of 7 inches. Shield must extend from the motor plate to at least 1 inch behind the clutch assembly. Flywheel shield meeting SFI Spec 6.1 minimum mandatory on all other cars. Multi-stage lockup-type clutch prohibited. Clutch release must be manually operated by driver's foot: Electronics, pneumatics, hydraulics, or any other device may in no way affect the clutch operation. NHRA-accepted physically challenged hand controls permitted. See General Regulations 2:3, 2:5, 2:6, 2:9.

DRIVELINE

When the driveshaft contains universal joints, a driveshaft meeting SFI Spec 43.1 is mandatory in AA/AM, BB/A, BB/AM, AA/AT, BB/AT, CC/AT, DD/AT, A/A, A/AP, B/A, B/AP, C/A, A/AA, B/AA, and C/AA. See General Regulations 2:4.

TRANSMISSION, AUTOMATIC

Permitted in AA/AM, AA/AT, BB/A, CC/A, BB/AM, BB/AT, CC/AT, DD/AT, A/AA through L/AA, AA/AF, BB/AF, B/SR, and C/SR. Cars with fully automatic transmissions with converter in A/AA may be 100 pounds under calculated class weight; classes B/AA through I/AA may be 250 pounds under calculated class weight; J/AA through L/AA may be 150 pounds under calculated class weight. CC/A with fully automatic transmission may deduct 225 pounds; Lenco-drive-type transmission may deduct 150 pounds (for CC/A only). CC/A may be under posted minimum weight, maximum 50 pounds. Except as noted above (for CC/A only), at no time, regardless of transmission, may a vehicle be under the minimum weight as stipulated under class designations. See Section 12, Transmission, Automatic, for details.

TRANSMISSION, MANUAL

Permitted in AA/AM, AA/AT, BB/A, CC/A, BB/AM, BB/AT, CC/AT, DD/AT, A/A through L/A, AA/AF, BB/AF, and A/SR. Classes A/AP and B/AP limited to planetary transmission with a maximum three forward speeds only. See Section 12, Transmission, Manual, for details.

BRAKES & SUSPENSION: 3**BRAKES**

Two rear-wheel hydraulic brakes mandatory. Hand brake, if used, must be located inside roll cage. Steel brake lines mandatory. See General Regulations 3:1.

STEERING

Minimum steering-wheel diameter 11 inches. See General Regulations 3:3.

SUSPENSION

Full automotive-type front suspension mandatory on all cars with wheelbase less than 120 inches. Minimum one hydraulic shock absorber per sprung wheel mandatory. Four-link rear-suspension car may use a single spring and shock absorber. Rigid-mounted rear axles permitted. See General Regulations 3:4.

TRACTION BARS

Permitted. See General Regulations 3:5.

FRAME: 4**BALLAST**

Permitted, must be located inside body line. See General Regulations 4:2.

BUMPERS, ALTEREDS, FRONT & REAR

Mandatory on full-bodied cars, fiberglass duplicates permitted. Optional on open-bodied cars; if used, must conform to original specifications. Push bars recommended in place of rear bumpers on open-bodied cars. Total weight of bumper and/or push bar with brackets not to exceed 50 pounds.

BUMPERS, STREET ROADSTERS, FRONT & REAR

Optional; if used, must be as wide as the outside of the adjacent tire treads and at least 3 inches tall for the entire width. Front bumper may not extend more than 30 inches forward of the centerline of the front spindle. Disguised spoilers prohibited.

ROLL CAGE

Mandatory. All chassis must meet the following SFI Spec: AA/M through G/A, B/AA through G/AA, I/A through K/A, and I/AA through K/AA must meet SFI Spec 25.1, 25.2, 25.3, 25.4, or 25.5 as applicable; open-bodied cars must meet SFI Spec 10.1, 10.2, 10.3, or 10.4 as applicable. All others must conform to the SFI Spec for the body style used. See General Regulations 4:4, 4:11, 10:6.

ROLL-CAGE PADDING

Roll-cage padding meeting SFI Spec 45.1 mandatory anywhere driver's helmet may come in contact with roll-cage components. See General Regulations 4:11.

WHEELBASE, ALTEREDS

Minimum 90 inches; maximum 125 inches. Maximum wheelbase variation from left to right: 1 inch.

WHEELBASE, STREET ROADSTERS

Must retain stock wheelbase, +/- 3/4-inch for body used. Front tread width must remain within 3 inches of stock. Axles, body location must remain as originally produced. Axle relocation prohibited. Minimum wheelbase 90 inches. Maximum variation from left to right: 1 inch.

TIRES & WHEELS: 5**TIRES**

Tires must be specified for racing use by manufacturer. See General Regulations 5:1.

WHEELS

Aftermarket wheels permitted. Automotive-type wire wheels and motorcycle wheels prohibited. Minimum wheel size 13 inches unless car was originally equipped with smaller wheels and is using original engine. See General Regulations 5:2.

INTERIOR: 6**TONNEAU COVER**

Covers permitted over driver compartment and/or pickup beds if they do not restrict driver entry/exit.

UPHOLSTERY

For supercharged or turbocharged open-bodied cars (gasoline- or methanol-burning), a flame-retardant-material-covered seat is mandatory.

BODY: 7**AIR DAM, OPEN-WHEEL VEHICLES**

Front air dam permitted. Maximum projection ahead of spindle centerline: 30 inches. Air dam may incorporate a flat, level (within 1 inch for crown) panel to cover the framerrails. Panel may extend from axle/spindles to front of grille shell. (See also Grille.) Maximum rise from front of air dam to rear edge of panel is 12 inches. Width of air dam may not exceed front tread width in front of spindles, and panel may not exceed width of a position flush with the outside of the top or side of framerrails behind the spindles. Panel may not attach to the grille shell in any manner. A demarcation line at the axle/spindle point must be present. Disguised streamlining prohibited. For AA/M, AA/AT, BB/A, BB/AM, BB/AT, A/A, A/AA, A/AP, B/A, B/AA, B/AP, C/A, and C/AA, both an air dam and/or a front wing are permitted.

BELLY PAN

Permitted.

BODY, FULL-BODIED CARS

Must have coupe, sedan, pickup truck, or convertible body commercially available, NHRA accepted. Tops may be chopped and/or channeled, not to exceed 10 inches total height reduction. All bodies must originate from and resemble a production vehicle; may be altered in height, width, length, and contour, etc. For full-bodied altered, the maximum front end overhang for the 1994-1995 Chevrolet Lumina is 47.375 inches, 1994-1997 Pontiac Firebird is 50 inches, 1998-2002 Pontiac Trans Am/Firebird is 46.375 inches, and 1998-2002 Chevrolet Camaro is 46.25 inches. For all other applications, the maximum is 45 inches. At least two openings for driver entry/exit mandatory. Body setback on pre-1949 model-year cars must not exceed 20 inches as measured from rear axle to center of original wheelwell location. Fiberglass bodies permitted. Door hinges on any lift-off door must have safety pins or locks.

BODY, ROADSTERS

Roadster body accepted by NHRA mandatory. May be channeled maximum 10 inches. Open touring and roadster pickups permitted. Removable turtle decks may be repositioned. Cowl may extend forward in place of hood. Rear wing and/or spoiler permitted; adjustment during run prohibited. See General Regulations 7:1.

BODY, FUNNY CAR

Any 1969 or later model-year coupe, sedan, or station wagon of a type originally produced by an automobile manufacturer, the body of which originally measured 63 inches wide or more at centerline of front and rear axles. Bodies may be narrowed to 60 inches; will be measured at centerline of existing front axle.

Fender flares and/or lips not on original factory-produced bodies will not be considered in any width measurement. Duplications of production bodies of fiberglass or aluminum permitted.

Body may be lengthened or shortened. Tops may be chopped, maximum 2 inches. Complete removal of top prohibited.

BODY, STREET ROADSTERS

Must be pre-1937 roadster body accepted by NHRA. Non-listed bodies not eligible for competition. All bodies must originate from and resemble a production vehicle; may be altered in height, width, length, and contour, etc. Traditional hot-rod-type louvers permitted. May be incorporated into the hood and/or hood-side panels, lower third of the rearmost portion of the fenders, the rear deck lid and/or valance panel. Louvers prohibited in running boards or any other body panels not specified above. Contact NHRA for complete specifications on size and placement.

FENDERS, ALTEREDS

Optional on pre-1949 cars; if used, must retain OEM configuration. Cars 1949 and later must retain 4 factory production-type fenders. Fiberglass reproductions permitted. Fenders may be moved up equal to amount of body channel. Cars 1960 model year and later in classes AA/AM, AA/AT, BB/A, BB/AM, BB/AT, A/AP, A/A, B/AP, B/A, CC/AT, or DD/AT may lengthen body maximum 6 inches to accommodate longer wheelbase. One-piece, lift-off front end permitted in AA/AF and BB/BF. May be widened for larger tires. Final approval rests with NHRA Technical Services. Rear fenders may be flared, bulged, and/or bubbled to allow for larger tires. See General Regulations 7:3.

FENDERS, STREET ROADSTERS

Four stock production fenders mandatory for body used. Exact replicas in fiberglass permitted. Bubbles for wider or taller tires prohibited. Rear fenders may be trimmed even with body at trailing edge and raised amount of body channel. Rear fenders may be increased in width to cover tire tread; maximum width 15 inches from body deck and may also be altered in height, length, and contour, etc. See General Regulations 7:3.

FIREWALL

Mandatory. See General Regulations 7:4.

FLOOR

Mandatory. BB/AF: Horizontal portion(s) of floorpan may be removed from behind B-post or roll cage main hoop attachment points (whichever is farther rearward) to rear of car. Entire shock/strut tower structure must be retained. Portion of floor removed must be replaced with aluminum or steel, completely sealed. Complete, unaltered OEM floorpan from B-post or roll cage main hoop attachment points (whichever is farther rearward) to front of strut tower mandatory. Complete, unaltered OEM firewall mandatory. See General Regulations 7:5.

GRILLE, PRE-1949

Must be fitted with stock production-type shell as large in frontal area as body's original radiator shell. Radiator shell may be altered in height only, not to exceed amount of body channeling, 10 inches in Altered. Grille/grille shell must be a stand-alone unit in normal vertical position; may not be molded into or attached to front air dam or tipped from vertical.

GRILLE, 1949 AND NEWER

An original-type grille; frontal dimensions and appearance must be retained.

GRILLE, ROADSTER

Must use a stock grille/radiator shell for body claimed; must remain in standard vertical position. May be altered in height by amount of channel only, 6 inches maximum.

HOOD, HOOD SCOOP, ALL VEHICLES

Hood permitted, but must conform to original-type dimensions for body used. Hood may not be re-contoured to affect streamlining. Must have a flash shield over carburetion in place of hood; see General Regulations 1:4. On full-bodied cars, hood-scoop opening may not extend more than 11 inches above height of original-type hood surface. On open-bodied cars, hood scoop may not extend more than 11 inches above height of carburetor top. On pre-1949, hood scoop may not extend into or over body lines. Scoop may be molded to original-type hood. Scoop may not extend more than 10 inches behind the engine. Any portion of the scoop that extends beyond the engine must have a minimum three-inch air gap between the scoop and any adjacent body or cowl surface. Disguised streamlining prohibited. For CC/A, cowl induction hood or blisters/bubbles permitted, maximum height 11 inches as measured from adjacent hood surface to highest point. See General Regulations 7:6.

SPOILERS, FULL-FENDERED CARS

OEM-type front spoilers permitted. Aftermarket spoiler not to exceed 30 inches forward of center of spindle. May not be higher than bottom of front bumper. Aftermarket rear spoiler may not be more than 4 inches above adjacent body surface. Maximum length 14 inches, measured from body line to spoiler transition point to tip. Maximum spill-plate length equal to spoiler length plus 2 inches. Maximum height of spill plate 6 inches; must be attached to spoiler so that a maximum 1 inch extends above the edge of spoiler. Any style rear wing and/or spoiler permitted on full-bodied cars running 180 mph or faster. Adjustment during run prohibited.

SPOILERS, STREET ROADSTERS

Aftermarket rear spoiler and/or wing permitted. Spoiler and/or wing may not be more than 4 inches above adjacent body surface or extend beyond width of car body or over fenders at mounting point. Maximum length: 14 inches, measured from body line/spoiler-transition point to tip. Molded-in spoilers prohibited. Adjustment during run prohibited.

WINGS

Permitted on open-wheel altered only. Must be mounted to cage or frame. Adjustment during run prohibited. Maximum 750 square inches of wing area.

WHEELWELLS

May be enlarged to permit use of larger tires if new wheelwells are constructed to completely cover inside and top 180 degrees of wheel and completely isolate wheels and tires from driver compartment. Rear-wheel tread width may be narrowed; on pre-1949 vehicles at least 50 percent of tread of each rear tire must remain outside body lines, as measured at body's narrowest point adjacent to rear wheelwell, without fenders, or a minimum of 38 inches.

WINDSHIELD, WINDOWS

Windshield/rear window optional. Windscreen mandatory in place of windshield. Windscreen may not extend or begin more than 4 inches forward of the original windshield location. The middle 12 inches of the front of the windscreen may be either flat/straight or curved surface with a minimum (horizontal plane) radius of 12 inches from top to bottom. The windscreen must be at least 5 inches high and 12 inches wide. The windscreen must be installed such that it will divert wind, liquids, and foreign matter over the driver's head. Windscreen must be securely mounted and installed in such a manner that it does not obstruct the driver's frontal view in any way. Disguised

streamlining prohibited. Five-inch-minimum-height window openings mandatory in all coupes, sedans, roadsters, measured vertically. Windshield and rear window angles may be altered to accommodate top chop. See General Regulations 7:8.

ELECTRICAL: 8

IGNITION

MSD 7531-4 permitted in AA/AF only. See General Regulations 8:1, 8:3, 8:4, 8:5.

SUPPORT GROUP: 9

FIRE EXTINGUISHER SYSTEM

See General Regulations 9:3.

DRIVER: 10

DRIVER

Must be located behind engine and completely within body contour with no part of driver behind rear axle.

HELMET

For all closed-bodied cars, a full-face Snell M2010, M2015, SA2010, or SA2015 helmet mandatory; shield mandatory in cars 7.49 seconds or quicker (goggles prohibited).

For all front-engine, open-bodied, supercharged or turbocharged cars, a full-face Snell SA2010, or SA2015 helmet and shield mandatory (goggles prohibited).

For all open-bodied naturally aspirated cars, a full-face Snell M2010, M2015, SA2010, or SA2015 helmet and shield mandatory (goggles prohibited). See General Regulations 10:7.

NECK COLLAR/HEAD AND NECK RESTRAINT DEVICE/SYSTEM

Head and neck restraint device/system meeting SFI 38.1 mandatory in AA/AM, AA/AT, BB/AT, CC/AT, A/AP, A/A, A/AA, B/A, B/AA, CC/A, BB/A, BB/AM, DD/AT, B/AP, C/A, C/AA, and AA/AF. Neck collar meeting SFI Spec 3.3 mandatory in all other classes. See General Regulations 10:8.

PROTECTIVE CLOTHING

For naturally aspirated closed-bodied cars, jacket and pants meeting SFI Spec 3.2A/5 and gloves meeting SFI Spec 3.3/1 mandatory, except cars running 7.49 or quicker, jacket and pants or suit meeting SFI Spec 3.2A/15, gloves meeting SFI Spec 3.3/5, and boots or shoes meeting SFI Spec 3.3/5 mandatory.

For naturally aspirated open-bodied cars, jacket and pants meeting SFI Spec 3.2A/5, gloves meeting SFI Spec 3.3/5, and boots or shoes meeting SFI Spec 3.3/5 mandatory, except cars running 7.49 or quicker, jacket and pants or suit meeting SFI Spec 3.2A/15 mandatory.

All naturally aspirated open-bodied cars require an SFI 3.3 head sock or an SFI 3.3 skirted helmet.

For supercharged or turbocharged closed-bodied (gasoline-burning) cars, jacket and pants meeting SFI Spec 3.2A/5, gloves meeting SFI Spec 3.3/5, and boots or shoes meeting SFI Spec 3.3/5 mandatory, except cars running 7.49 or quicker, jacket and pants or suit meeting SFI Spec 3.2A/15 mandatory.

For supercharged or turbocharged open-bodied cars and closed-bodied methanol-burning cars, a suit meeting SFI Spec

3.2A/15, gloves meeting SFI Spec 3.3/15 and boots or shoes meeting SFI Spec 3.3/15 mandatory.

A suit meeting SFI Spec 3.2A/15, gloves meeting SFI Spec 3.3/5, and boots or shoes meeting SFI Spec 3.3/5 mandatory when automatic transmission (or converter) is located in driver compartment.

For supercharged or turbocharged open-bodied cars and closed-bodied methanol-burning cars, an SFI 3.3 head sock or skirted helmet is required.

An SFI 3.3 head sock or SFI 3.3 skirted helmet is required on all open-bodied cars or all cars 7.49 and quicker, where a neck collar is not used. See General Regulations 10:10.

SECTION 13E ALTERED TRUCK

Requirements and specifications for Altered Truck classes are the same as those for Comp - Section 12 - with the following exceptions:

DESIGNATIONS

PST, PS/TA, B/T, B/TA, C/T, C/TA, preceded by truck number.

Reserved for 1997 or later domestic or foreign pickups of extended cab, mid-size (Dakota, S-10, Ranger, etc.) class. Body, drivetrain, chassis, etc. may not be altered, modified, or relocated, except as outlined in Requirements & Specifications. Minimum weight at conclusion of run includes driver.

CLASSES

PST: 358-cubic-inch maximum; 2,300-pound minimum

PS/TA: 358-cubic-inch maximum; 2,300-pound minimum

B/T: 8.50 pounds per cubic inch, V-8 only; 2,300-pound minimum

B/TA: 8.50 pounds per cubic inch, V-8 only; 2,300-pound minimum

C/T: 8.50 pounds per cubic inch, V-6 only; 2,100-pound minimum

C/TA: 8.50 pounds per cubic inch, V-6 only; 2,100-pound minimum

REQUIREMENTS & SPECIFICATIONS

ENGINE: 1

CARBURETOR

Limited to two, and only two, NHRA-accepted 4-barrel American automotive production carburetors, with any internal modifications. The following are prohibited: "inline" multibarrel, slide valve, and/or motorcycle carburetors, and/or fuel injection.

CYLINDER HEADS

Must be OEM, generally available, and NHRA-accepted, with OEM part/casting number cast into head. Cylinder head must be available as a finished piece with valve guides and valve seats installed. Any valve configuration or size permitted. As-produced valve cover mounting surface required and as-produced head height (thickness) may not be exceeded. Ports may be raised. Exhaust port plate permitted, may be higher than head, no wider than 1 1/2 inches, may not be recessed into port more than plate width. Intake port plate prohibited. Maximum two valves per cylinder, maximum one spark plug per cylinder.

ENGINE

Internal-combustion, reciprocating, naturally aspirated, single-camshaft, small-block, 90-degree V-8 automotive-type engine. OEM bore center spacing mandatory. Block must be cast iron, OEM generally available, and NHRA-accepted, with OEM part/casting number cast into block. Maximum one distributor. PST and PS/TA may use engines up to 369 cubic inches maximum but must add 7 pounds per cubic inch to the minimum weight for each cubic inch over 358. See General Regulations 1:2.

ENGINE SETBACK

Maximum engine setback, from centerline of front spindle to center of front spark-plug hole, 6 inches for PST, PS/TA, B/T, and B/TA; 11 inches for C/T and C/TA.

FUEL

NHRA-accepted racing gasoline only. Propylene oxide and/or nitrous oxide prohibited. See General Regulations 1:6.

FUEL SYSTEM

Fuel cell meeting SFI Spec 28.1 mandatory; must have pressure cap and be vented to outside of body. If mounted in front of radiator, must be installed between framerrails and enclosed in a round tube frame, minimum 1 1/4-inch o.d. x .065-inch chromoly tubing. Extra tank(s) prohibited. Artificial cooling or heating systems (i.e., cool cans, ice, Freon, etc.) prohibited. See General Regulations 1:5.

RADIATOR

Only one full-size automotive radiator in front location, with only one stock-type water pump mandatory. External plumbing from water pump to block and/or cylinder head(s) permitted. Water pump and fan may be electrically driven.

DRIVETRAIN: 2**CLUTCH, FLYWHEEL, AND FLYWHEEL SHIELD**

Flywheel and clutch meeting SFI Spec 1.1, 1.2, 1.3, or 1.4 mandatory. Flywheel shield meeting SFI Spec 6.2 or 6.3 mandatory on all trucks using SFI Spec 1.2 clutch (3 or more discs) or 1.3 or 1.4 clutch (2 disc max). Flywheel shield meeting SFI Spec 6.2 mandatory on any truck using SFI Spec 1.3 or 1.4 clutches with 3 or more discs. Flywheel shield meeting minimum SFI Spec 6.1 mandatory on all other trucks. Clutch must be manually operated by driver's foot: Electronics, pneumatics, hydraulics, or any other device may in no way affect the clutch system. Multi-stage, variable release-type clutch of any description prohibited. Throwout bearing must release all fingers, levers, stages, etc. simultaneously.

Flywheel shield cannot be welded into the truck and/or (used as a crossmember) frame. Frame and/or body braces cannot be welded to flywheel shield. Clutch release must be manually operated by driver's foot; electronics, pneumatics, hydraulics, or any other device may in no way affect the clutch operation. See General Regulations 2:3, 2:5, 2:6, 2:9.

DRIVELINE

Driveshaft meeting SFI Spec 43.1 mandatory in PST and PS/TA. See General Regulations 2:4.

TRANSMISSION, AUTOMATIC

Permitted in PS/TA, B/TA, and C/TA. See Section 12, Transmission, Automatic, for details.

TRANSMISSION, MANUAL

Permitted in PST, B/T, and C/T. See Section 12, Transmission, Manual, for details.

BRAKES & SUSPENSION: 3**BRAKES**

Automated brakes prohibited; application and release of brakes must be a function of the driver. Four-wheel hydraulic brakes mandatory. Brake lines must be out of flywheel and driveline area. Line-loc permitted on front wheels only. One line-loc solenoid, one button, only. Any other electrical, pneumatic, hydraulic, etc. switch prohibited in brake system. See General Regulations 3:1.

STEERING

Aftermarket or replacement rack and pinion permitted. Commercially available quick-disconnect steering wheel meeting SFI Spec 42.1 mandatory. Minimum steering-wheel diameter 11 inches. See General Regulations 3:3.

SUSPENSION

Full automotive systems mandatory. Minimum one hydraulic shock absorber per wheel. Lightening of stock components prohibited. Rigid-mounted suspensions or straight front axle prohibited. See General Regulations 3:4.

FRAME: 4**BALLAST**

Permitted. Any ballast mounted on, or in front of, forward crossmember is limited to 30 pounds maximum, including bracket. Maximum length of bracket 12 inches, measured from the front of the crossmember. Maximum distance from front motor plate to front of bracket is 36 inches. Bracket may be constructed of either minimum 1 1/4-inch x .058-inch wall round chromoly tubing with minimum four (4) 3/8-inch-diameter SAE Grade 8 bolts for attachment, or of minimum 1/4-inch 6061 T6 aluminum plate with minimum four (4) 1/2-inch SAE Grade 8 bolts for attachment, or NHRA-accepted design. All other weight bars, pucks, etc. must use minimum 1/2-inch-diameter SAE Grade 8 bolts for attachment. See General Regulations 4:2.

BUMPERS

Original or fiberglass-duplicate front bumper mandatory. Original or fiberglass-duplicate bumper, or roll pan, mandatory on rear. Duplicate bumper(s) must retain original size, shape, and appearance.

PARACHUTE

Mandatory. Rear of chute pack cannot be forward of rear tip of spoiler. A bushing is mandatory over the shroud-line mounting bolt(s). Lower parachute mounting supports must be bolted; upper mounts may be pinned. See General Regulations 4:8.

ROLL CAGE

Chassis must meet SFI Spec 25.1. See General Regulations 4:4, 4:11, 10:6.

ROLL-CAGE PADDING

Roll-cage padding meeting SFI Spec 45.1 mandatory anywhere driver's helmet may come in contact with roll-cage components. See General Regulations 4:11.

WHEELBASE

Wheelbase minimum 124 inches, maximum 125 inches. Maximum variation from left to right, 1 inch.

TIRES & WHEELS: 5**TIRES**

Clearance from outside of front tire to inside of fender at closest point not to exceed 4 inches. Rear clearance 3 inches from outside of tire to inside of fender at widest point. Inner liners permitted. See General Regulations 5:11.

WHEELS

Rear wheels meeting SFI Spec 15.1 mandatory; maximum width, 16 inches. Wheel discs or covers prohibited. See General Regulations 5:2.

INTERIOR: 6**UPHOLSTERY**

Driver's seat must be minimum 24 inches high. Padded upholstery mandatory. Removal of passenger seat permitted. Seat frame must be installed as a permanent part of the chassis. Dashboard exterior appearance must be retained. Fiberglass replica of original permitted. Gauges may be painted in or simulated. Headliner area must be finished (painted). See General Regulations 6:2.

WINDOW NET

Window net meeting SFI Spec 27.1 mandatory. See General Regulations 6:3.

BODY: 7**AIR DAM**

Aftermarket front air dam permitted; may not extend beyond forwardmost point of bumper. Fiberglass or other lightweight material permitted.

BODY

Only mid-size, extended-cab pickup body permitted; must be NHRA-accepted prior to use. Original OEM cab shell and bed sides or NHRA-accepted composite replacements mandatory. OEM body panels, or fiberglass or other lightweight components permitted. Fiberglass or other lightweight components limited to hood, front fenders, doors, valance panels, and tailgate; must be exact duplicates of original components. Chopping, channeling, sectioning, or other alterations to contour, length, width, or height prohibited. Flatbed cover mandatory. NHRA acceptance of body mandatory regardless of manufacturer.

DOORS

Must be functional and operable from inside and outside. Exact duplicates in fiberglass permitted; must have sheet-metal deflector plate between fenders and leading edge of doors.

FENDER SPLASH PANS

Front mandatory.

FIREWALL

Moving stock firewall rearward for engine installation permitted. Replacing stock unit with one of .024-inch steel or .032-inch aluminum permitted. See General Regulations 7:4.

FLOOR

Replacing stock floors with .024-inch steel or .032-inch aluminum permitted. Replaced floors must be stock in appearance and location. Driver's-side floor pan must be steel and must be welded in place. Subfloors and/or belly pans prohibited. Chassis, frame, and driveline must be below floor. Rear floor may not be higher than 8 inches above door sill. Driveline tunnel behind driver's seat may be higher for proper clearance. Magnesium interior panels prohibited. See General Regulations 7:5.

FRONT OVERHANG

Maximum 34 inches measured from spindle centerline to forwardmost point of truck.

HOOD

Mandatory. Duplicate replacement fiberglass hood permitted. Hood scoop prohibited in PST and PS/TA. Hood-scoop opening

may not extend more than 11 inches above height of original-type hood surface. Tilt front ends prohibited. A minimum of four fasteners must be used on the leading edge of all lift-off hoods. Cowl-induction hood permitted. See General Regulations 7:6.

GRILLE

One-piece front assembly to replace original fascia permitted; may be fiberglass or other lightweight material; stock headlight and parking-light lenses must be retained in original location. Original grille and fascia may be simulated. Maximum 4-inch x 18-inch opening permitted in grille for fresh-air ducting to carburetors. May have covering over back of grille to prevent air passage. Any factory accessory packages must be accepted by NHRA.

SPOILER

Maximum length of rear spoiler 14 inches, measured from the body line/tailgate to spoiler transition point to the tip. May not be molded into body. Spoiler must be mounted to tailgate. Spoiler must be flat; no bow or crown. All spoilers to be painted to match paint scheme. No lower than horizontal. Roof-mounted spoilers prohibited. Wings prohibited. Any adjustment or movement during run prohibited.

STREET EQUIPMENT

Complete stock sealed-beam headlight lens, parking light, and taillight lenses must be retained in original factory location. Headlights, parking, stop, and taillight cannot be painted on body. Side marker lights optional. Any other street equipment that does not affect external appearance may be removed.

WHEELWELLS

Rear wheelwells must be separate for each tire. Height of tub not to exceed top of bed side.

WINDSHIELD, WINDOWS

Full windows mandatory; 1/8-inch polycarbonate material permitted. Must match original contour and mount in stock location. Windows must be closed; need not be operative. Cutting or notching windshield permitted if covered by hood. See General Regulations 7:8.

ELECTRICAL: 8

BATTERIES

Maximum two batteries permitted; may be relocated to truck bed. Maximum weight, fully charged, including battery box: 100 pounds. See General Regulations 8:1, 8:4.

DISTRIBUTOR

Maximum one distributor.

SUPPORT GROUP: 9

FIRE EXTINGUISHER SYSTEM

Fire extinguishing system must meet SFI Spec 17.1. Minimum 5-pound NHRA-accepted fire extinguishing system mandatory. System must be divided with one nozzle on driver's side and one nozzle on engine. See General Regulations 9:3 for NHRA-accepted fire extinguishing agents.

DRIVER: 10

HELMET

For all trucks, a full-face Snell M2010, M2015, SA2010, or SA2015 helmet mandatory; shield mandatory in vehicles 7.49 seconds or quicker (goggles prohibited). See General Regulations 10:7.

NECK COLLAR/HEAD AND NECK RESTRAINT DEVICE/SYSTEM

Head and neck restraint device/system meeting SFI 38.1 mandatory in PST. Neck collar meeting SFI Spec 3.3 mandatory in all other classes. See General Regulations 10:8.

PROTECTIVE CLOTHING

Jacket and pants meeting SFI Spec 3.2A/5, gloves meeting SFI Spec 3.3/1, and shoes meeting SFI Spec 3.3/1 mandatory, except cars running 7.49 or quicker, jacket and pants or suit meeting SFI Spec 3.2A/15, gloves meeting SFI Spec 3.3/5, and boots or shoes meeting SFI Spec 3.3/5 mandatory. An SFI 3.3 head sock or SFI 3.3 skirted helmet is required on all cars 7.49 and quicker, where a neck collar is not used. See General Regulations 10:10.

SECTION 13F ECONO ALTERED

Requirements and specifications for Econo Altered classes are the same as those for Comp - Section 12 - with the following exceptions:

DESIGNATIONS

A/EA, B/EA, C/EA, D/EA, E/EA, F/EA, G/EA, and H/EA, preceded by car number. Classes of competition within Econo Altered are for naturally aspirated, single-engine gas Altered or Funny Cars. Class determined by total car weight (including driver) divided by total engine displacement (cubic inches).

CLASSES

- A/EA: 5.00 or more pounds per cubic inch; V-8 only; 1,500-pound minimum
- B/EA: 6.50 or more pounds per cubic inch; V-8 only; 1,700-pound minimum
- C/EA: 7.50 or more pounds per cubic inch; V-8 only; 1,700-pound minimum
- D/EA: 7.50 or more pounds per cubic inch, V-6 only; 1,700-pound minimum
- E/EA: 6.00 or more pounds per cubic inch. Inline or opposed 6-cylinder engines, 2-valve only; 1,100-pound minimum
- F/EA: 6.00 or more pounds per cubic inch. Inline or opposed 6-cylinder engines, 4-valve only; 1,100-pound minimum
- G/EA: 6.25 or more pounds per cubic inch. Inline 4-cylinder engines, 2-valve only; 1,100-pound minimum
- H/EA: 8.25 or more pounds per cubic inch. Inline 4-cylinder engines, 4-valve only; 1,100-pound minimum

REQUIREMENTS & SPECIFICATIONS

ENGINE: 1

CARBURETORS

Class A, one NHRA-accepted 4-barrel, maximum 850cfm, standard OEM configuration. Classes B, C, and D, one NHRA-accepted 4-barrel, maximum 750cfm, standard OEM configuration. Class E, any production carburetor(s), as listed in NHRA Blueprint Bulletins. Classes A/EA through D/EA, throttle bore restricted to manufacturer's dimension, measured at largest point, venturi restricted to manufacturer's dimension plus .025-inch, measured at largest point. F/EA through H/EA: any standard OEM carburetor(s) permitted. Car manufacturer must be represented in NHRA Blueprint Bulletins. Weber or Weber-type

carburetor restricted to 55mm Weber or equivalent. All classes, minimum throttle-shaft diameter .085-inch, measured at thinnest point. All classes, minimum throttle-plate thickness .040-inch, measured at thinnest point. The following are prohibited in all classes: throttle-bore modifications, cutting and reconfiguring, inline multibarrel (i.e., more than two) configuration, slide valve carburetors, motorcycle carburetors, fuel injection.

CYLINDER HEADS

All heads must be NHRA-accepted, two valves per cylinder OEM casting (no billet) with OEM number cast into head, except as noted in F/EA and H/EA. A/EA: hemi, canted/splayed valve, or wedge head permitted. B/EA: canted/splayed valve or wedge head permitted. C/EA: true wedge cylinder heads (with inline and parallel valves) only. Porting, polishing permitted; header plates permitted. Exhaust port plates that protrude into port prohibited. Any size valves permitted, valves may be tilted and/or canted. Angle milling and/or rolling permitted. External modifications permitted. Combustion-chamber modifications permitted. The valve cover rail may be modified. Heads may be cut for larger pushrods and springs. Spark-plug holes must be in NHRA-approved location. Siamese-configured cylinder heads are prohibited in E/EA and G/EA.

ENGINE

One only, must be OEM or NHRA-accepted aftermarket, naturally aspirated, automobile engine generally available. Class D/EA restricted to one camshaft per engine in original location. OEM bore center spacing mandatory. Rear engine location prohibited. See General Regulations 1:2.

ENGINE SETBACK

Any setback permitted. Driver must sit behind engine, in front of rear axles.

FUEL

NHRA-accepted racing gasoline only. Propylene oxide and/or nitrous oxide prohibited. See General Regulations 1:6.

SPARK PLUGS

The use of angle-tipped spark plugs is prohibited.

OIL SYSTEMS

Dry-sump oil systems prohibited. External single-stage oil pumps permitted; additional pump stages are limited to non-oil-pump functions such as vacuum pump, water pumps, etc.

DRIVETRAIN: 2

DRIVELINE

See General Regulations 2:4.

TRANSMISSION, AUTOMATIC

Permitted. See Section 12, Transmission, Automatic, for details.

TRANSMISSION, MANUAL

Prohibited.

BRAKES & SUSPENSION: 3

BRAKES

Two rear-wheel hydraulic brakes mandatory. Hand brake, if used, must be located inside roll cage. Steel brake lines mandatory. See General Regulations 3:1.

STEERING

Minimum steering-wheel diameter 11 inches. Butterfly wheel permitted in open-wheel vehicle. See General Regulations 3:3.

SUSPENSION

Full automotive-type front suspension mandatory on all cars with

wheelbase less than 120 inches. Minimum one hydraulic shock absorber per sprung wheel mandatory. Four-link rear-suspension car may use a single spring and shock absorber. Rigid-mounted rear axles permitted. See General Regulations 3:4.

SUSPENSION, FUNNY CARS

Front and rear suspension optional.

TRACTION BARS

Permitted. See General Regulations 3:5.

FRAME: 4

BALLAST

Permitted. See General Regulations 4:2.

BUMPERS

Mandatory on full-bodied cars, fiberglass duplicates permitted. Optional on open-bodied cars; push bars recommended in place of rear bumpers on open-bodied cars. Total weight of bumper and/or push bar with brackets not to exceed 50 pounds.

ROLL CAGE

Mandatory. Cars in A/EA must conform to SFI Spec 10.1 or 10.2 (open body), 25.1, 25.2, or 25.3 (full body). All chassis must meet the following SFI Spec: Full-bodied vehicles in B/EA through F/EA must meet SFI Spec 25.1, 25.4, or 25.5 as applicable; open-bodied vehicles must meet SFI Spec 10.1, 10.2, or 10.3 as applicable. All others must conform to the SFI Spec for the body style used. See General Regulations 4:4, 4:11, 10:6.

ROLL-CAGE PADDING

Roll-cage padding meeting SFI Spec 45.1 mandatory anywhere driver's helmet may come in contact with roll-cage components. See General Regulations 4:11.

WHEELBASE, ALTEREDS

Minimum 90 inches; maximum 125 inches. Maximum wheelbase variation from left to right: 1 inch.

WHEELBASE, FUNNY CARS

Minimum 100 inches; maximum 125 inches. Rear tread cannot be outside of body line, nor more than 3 inches inside of body line. Front tread, no more than 6 inches inside body line. Measurements are taken from outside edge of tire to inside edge of body. Maximum wheelbase variation from left to right: 1 inch.

TIRES & WHEELS: 5

TIRES

Tires to be automotive type represented by manufacturer for Comp. See General Regulations 5:1.

WHEELS

Aftermarket wheels permitted. Automotive-type wire wheels and motorcycle wheels prohibited. Minimum wheel size 13 inches unless car was originally equipped with smaller wheels and is using original engine. See General Regulations 5:2.

INTERIOR: 6

TONNEAU COVER

Covers permitted over driver compartment and/or pickup beds if they do not restrict driver entry/exit.

BODY: 7

AIR DAM, OPEN-WHEEL VEHICLES ONLY

Front air dam permitted. Maximum projection ahead of spindle

centerline: 30 inches. Air dam may incorporate a flat, level (within 1 inch for crown) panel to cover the framerrails. Panel may extend from axle/spindles to front of grille shell. (See also GRILLE.) Maximum rise from front of air dam to rear edge of panel is 12 inches. Width of air dam may not exceed front tread width in front of spindles and panel may not exceed width of a position flush with the outside of the top or side of framerrails behind the spindles. Panel may not attach to the grille shell in any manner. A demarcation line at the axle/spindle point must be present. Disguised streamlining prohibited.

BELLY PAN

Permitted.

BODY, FULL-BODIED CARS

Must have coupe, sedan, or convertible body commercially available, NHRA accepted. Tops may be chopped and/or channeled, not to exceed 10 inches total height reduction. All bodies must originate from and resemble a production vehicle; may be altered in height, width, length, and contour. etc. For full-bodied econo alteredes, the maximum front-end overhang for the 1994-1995 Chevrolet Lumina is 47.375 inches, 1994-1997 Pontiac Firebird is 50 inches, 1998-2002 Pontiac Trans Am/Firebird is 46.375 inches, and 1998-2002 Chevrolet Camaro is 46.25 inches. For all other applications, the maximum is 45 inches. At least two openings for driver entry/exit mandatory. Body setback on pre-1949 model year cars must not exceed 20 inches as measured from rear axle to center of original wheelwell location. Fiberglass bodies permitted. Door hinges on any lift-off door must have safety pins or locks.

BODY, ROADSTERS

Roadster body accepted by NHRA mandatory. May be channeled maximum 10 inches. Open touring and roadster pickups permitted. Removable turtle decks may be repositioned. Cowl may extend forward in place of hood. Rear wing and/or spoiler permitted; adjustment during run prohibited. See General Regulations 7:1.

BODY, FUNNY CARS

Any 1969 or later model-year coupe, sedan, or station wagon of a type originally produced by an automobile manufacturer, the body of which originally measured 63 inches wide or more at centerline of front and rear axles. Bodies may be narrowed to 60 inches; will be measured at centerline of existing front axle. Fender flares and/or lips not on original factory-produced bodies will not be considered in any width measurement. Duplications of production bodies of fiberglass or aluminum permitted. Body may be lengthened or shortened. Tops may be chopped, maximum 2 inches. Complete removal of top prohibited.

FENDERS, ALTEREDS

Optional on pre-1949 cars. Cars 1949 and later must retain 4 factory production-type fenders. Fiberglass reproductions permitted. Cars 1960 model year and later in Econo Altered may lengthen body maximum 6 inches to accommodate longer wheelbase. Rear fenders may be flared, bulged, and/or bubbled to allow for larger tires. See General Regulations 7:3.

FIREWALL

Mandatory. See General Regulations 7:4.

FLOOR

Mandatory. See General Regulations 7:5.

GRILLE, ECONO ALTERED PRE-1949

Must be fitted with stock production-type shell as large in frontal area as body's original radiator shell. Radiator shell may be altered in height only, not to exceed amount of body channeling,

10 inches in Altered. Grille/grille shell must be a stand-alone unit in normal vertical position; may not be molded into or attached to front air dam or tipped from vertical.

GRILLE, ECONO ALTERED 1949 AND NEWER

Original-type grille and frontal dimensions must be retained.

GRILLE, FUNNY CAR

A grille or painted simulated grille of same configuration and design for body used mandatory.

HEADLIGHT OPENINGS

May be covered with a flat plate conforming to the shape of the opening but not extending forward of the opening or altering the fender or body shape.

HOOD, HOOD SCOOP

Optional. Must have a flash shield over carburetion in place of hood. On full-bodied cars, hood-scoop opening may not extend more than 11 inches above height of original-type hood surface. On open-bodied cars, hood scoop may not extend more than 11 inches above height of carburetor top. Scoop may not extend more than 10 inches behind the engine. Any portion of the scoop that extends beyond the engine must have a minimum three-inch air gap between the scoop and any adjacent body or cowl surface. See General Regulations 1:4.

SPOILERS, FULL-FENDERED CARS

OEM front spoilers permitted. Aftermarket spoiler not to exceed 30 inches forward of center of spindle. May not be higher than bottom of front bumper. Aftermarket rear spoiler may not be more than 4 inches above adjacent body surface. Maximum height of spill plate 6 inches; must be attached to spoiler so that a maximum 1 inch extends above the edge of spoiler. Maximum length 14 inches, measured from body line to spoiler transition point to tip. Any style rear wing and/or spoiler permitted on full-bodied cars running 180 mph or faster. Adjustment during run prohibited.

WHEELWELLS

May be enlarged to permit use of larger tires if new wheelwells are constructed to completely cover inside and top 180 degrees of wheel and completely isolate wheels and tires from driver compartment. Rear wheel tread width may be narrowed; on pre-1949 vehicles at least 50 percent of tread of each rear tire must remain outside body lines, as measured at body's narrowest point adjacent to rear wheelwell, without fenders, or a minimum of 38 inches.

WINDSHIELD, WINDOWS

Windshield/rear window optional. Windscreen mandatory in place of windshield. Window openings mandatory in all coupes, sedans, roadsters, 5 inches minimum height, measured vertically. Windscreen may not extend or begin more than 4 inches forward of the original windshield location. The middle 12 inches of the front of the windscreen may be either flat/straight or curved surface with a minimum (horizontal plane) radius of 12 inches from top to bottom. The windscreen must be at least 5 inches high and 12 inches wide. The windscreen must be installed such that it will divert wind, liquids, and foreign matter over the driver's head. Windscreen must be securely mounted and installed in such a manner that it does not obstruct the driver's frontal view in any way. Disguised streamlining prohibited. See General Regulations 7:8.

WING

Permitted on open-wheel altered only. Must be mounted to cage or frame. Adjustment during run prohibited. Maximum 750 square inches of wing area.

ELECTRICAL: 8**IGNITION**

See General Regulations 8:1, 8:3, 8:4, 8:5.

SUPPORT GROUP: 9**FIRE EXTINGUISHER SYSTEM**

Permitted. See General Regulations 9:3.

DRIVER: 10**DRIVER**

Must be located behind engine and completely within body contour with no part of driver behind rear axle.

HELMET

For all closed-bodied cars, a full-face Snell M2010, M2015, SA2010, or SA2015 helmet mandatory; shield mandatory in cars 7.49 seconds or quicker (goggles prohibited).

For all open-bodied cars, a full-face Snell M2010, M2015, SA2010, or SA2015 helmet and shield mandatory (goggles prohibited). See General Regulations 10:7.

NECK COLLAR/HEAD AND NECK RESTRAINT DEVICE/SYSTEM

Head and neck restraint meeting SFI 38.1 in A/EA mandatory. Neck collar meeting SFI Spec 3.3 mandatory in all other classes. See General Regulations 10:8.

PROTECTIVE CLOTHING

An SFI 3.3 head sock or SFI 3.3 skirted helmet is required on all open-bodied cars or all cars 7.49 and quicker, where a neck collar is not used. See General Regulations 10:10.

SECTION 13G SUPER MODIFIED

Requirements and specifications for Super Modified classes are the same as those for Comp - Section 12 - with the following exceptions:

DESIGNATIONS

A/SM, B/SM, C/SM, D/SM, E/SM, F/SM, G/SM, H/SM, I/SM, A/SMA, B/SMA, C/SMA, D/SMA, E/SMA, F/SMA, G/SMA, H/SMA, and I/SMA, preceded by car number.

No other modifications permitted in Super Modified unless outlined within the section.

Classes of competition within Super Modified are for naturally aspirated. 1967 or later automotive-production 2-door sedan or hardtop passenger cars of which 500 units must have been built and are showroom available. Front-wheel-drive conversions permitted. Class determined by total car weight (including driver) divided by total engine displacement (cubic inches).

CLASSES

A/SM: 7.50 or more pounds per cubic inch. Dual four-barrels; V-8 only; 2,750-pound minimum
 B/SM: 8.50 or more pounds per cubic inch. Dual four-barrels; V-8 only; 2,750-pound minimum

- C/SM: 8.50 or more pounds per cubic inch. V-8 only; 2,750-pound minimum
- D/SM: 9.50 or more pounds per cubic inch. Dual four-barrels; V-8 only; true wedge cylinder heads (with inline and parallel valves) only; 2,750-pound minimum
- E/SM: 9.50 to 10.49 pounds per cubic inch. Wedge or canted-valve cylinder heads, maximum 366 cubic inches; V-8 only; 2,750-pound minimum
- F/SM: 10.50 or more pounds per cubic inch. Dual four-barrels; true wedge cylinder heads (with inline and parallel valves) only; V-8 only; 2,750-pound minimum
- G/SM: 10.50 or more pounds per cubic inch. True wedge cylinder heads (with inline and parallel valves) only; maximum 366 cubic inches; 2,750-pound minimum
- H/SM: 11.50 or more pounds per cubic inch. Dual four-barrels, true wedge cylinder heads (with inline and parallel valves) only; maximum 366 cubic inches; V-8 only; 2,750-pound minimum
- I/SM: 11.50 or more pounds per cubic inch. Dual four-barrels or electronic fuel injection; V-6 only; 2,650-pound minimum

Classes A/SM through I/SM are manual transmission only. Classes A/SMA through I/SMA are automatic transmission and utilize corresponding manual-transmission displacements and minimum weights.

REQUIREMENTS & SPECIFICATIONS

ENGINE: 1

CARBURETOR

Class C, one NHRA-accepted 4-barrel, maximum 850cfm, standard OEM configuration. Classes E and G, one NHRA-accepted 4-barrel, maximum 750cfm, standard OEM configuration. Classes E and G, throttle bore restricted to manufacturer's dimension, measured at largest point, venturi restricted to manufacturer's dimension plus .025-inch, measured at largest point. Classes A, B, D, F, and H limited to two (only) NHRA-accepted 4-barrel American automotive production carburetors with any internal modifications. Class I limited to two (only) NHRA-accepted 4-barrel American automotive production carburetors with any internal modifications or NHRA-accepted American automotive production electronic fuel injection with any internal modifications. All classes, minimum throttle-shaft diameter .085-inch, measured at thinnest point. All classes, minimum throttle-plate thickness .040-inch, measured at thinnest point. Prohibited in classes A through I: throttle-bore modifications, cutting and reassembling, inline multibarrel (i.e., more than two) configuration, slide valve carburetors, motorcycle carburetors, mechanical fuel injection.

CYLINDER HEADS

Cylinder heads must be NHRA-accepted, two valves per cylinder. Aftermarket aluminum cylinder heads permitted (no billet). Hemi, canted/splayed valve, or wedge head permitted in A through C and I. Classes D, F, G, and H restricted to true wedge cylinder heads (with inline and parallel valves) only. Porting, polishing permitted; header plates permitted. Exhaust port plates that protrude into port prohibited. Any size valves permitted, valves may be tilted and/or canted. Angle milling and/or rolling permitted. External modifications permitted. Combustion-chamber modifications permitted. The valve cover rail may be modified. Heads may be cut for larger pushrods and springs. Spark plug holes must be in NHRA-accepted location.

ENGINE

Must be naturally aspirated in classes A through I. OEM block mandatory in A through I. Corporate engine permitted. Engine setback or raising engine prohibited. Motor plates and mid-mounts permitted. Any internal engine modification permitted. OEM bore center spacing mandatory. See General Regulations 1:2.

EXHAUST SYSTEM

Final outlet for open exhaust cannot exceed 4 inches in diameter. See General Regulations 1:3.

FUEL

NHRA-accepted racing gasoline only. Propylene oxide and/or nitrous oxide prohibited. See General Regulations 1:6.

SPARK PLUGS

The use of angle-tipped spark plugs is prohibited.

FUEL SYSTEM

Fuel cells permitted, 15-gallon maximum. May be relocated to trunk. Trunk must be completely isolated from driver compartment with firewall. Fuel cells must be located within body; if located outside of frame, fuel cell must be enclosed in a steel tube frame constructed of minimum 1 1/4-inch O.D. x .065-inch chromoly tubing. See General Regulations 1:5.

OIL SYSTEMS

Dry-sump oil systems prohibited. External single-stage oil pump permitted; additional pump stages are limited to non-oil-pump functions such as vacuum pump, water pumps, etc.

RADIATOR

Any radiator permitted. Water pump optional.

DRIVETRAIN: 2**CLUTCH, FLYWHEEL, FLYWHEEL SHIELD**

Flywheel and clutch meeting SFI Spec 1.1, 1.2, 1.3, or 1.4 mandatory. Flywheel shield meeting SFI Spec 6.2 or 6.3 mandatory on all cars using SFI Spec 1.2 clutch (3 or more discs) or SFI Spec 1.3 or 1.4 clutches (2 discs max). Flywheel shield meeting SFI Spec 6.2 mandatory with SFI Spec 1.3 or 1.4 clutch using 3 or more discs. Flywheel shield meeting minimum SFI Spec 6.1 mandatory on all other cars. Multi-stage lockup-type clutch prohibited. Clutch release must be manually operated by driver's foot: Electronics, pneumatics, hydraulics, or any other device may in no way affect the clutch operation. NHRA-accepted physically challenged hand controls permitted. See General Regulations 2:3, 2:5, 2:6, 2:9.

DRIVELINE

May be modified or fabricated to fit altered units. See General Regulations 2:4.

REAR END

Titanium rear-end housing prohibited.

TRANSMISSION, AUTOMATIC

Permitted in A/SMA, B/SMA, C/SMA, D/SMA, E/SMA, F/SMA, G/SMA, H/SMA, and I/SMA. Cars with automatic transmissions may remove 250 pounds from regular class weight. In no case may vehicle weigh less than the posted minimum weight for the class. See General Regulations 2:14. See Section 12, Transmission, Automatic, for details.

TRANSMISSION, MANUAL

Permitted in A/SM, B/SM, C/SM, D/SM, E/SM, F/SM, G/SM, H/SM, and I/SM. See Section 12, Transmission, Manual, for details.

TRANSMISSION FLUID RETENTION

Belly pan covering transmission permitted if it meets the following criteria:

1. Belly pan can only be as wide as to cover transmission and only as long as length of transmission from the front of the bellhousing to the rear of the tailshaft of the transmission.
2. Belly pan must have a 2-inch lip on all sides.
3. A nonflammable, oil-absorbent liner mandatory inside of belly pan. See General Regulations 1:8.

BRAKES & SUSPENSION: 3**BRAKES**

Four-wheel hydraulic brakes mandatory. Must incorporate dual master cylinder with any modified system. Rear wheel line-locs prohibited. Master cylinder may be mounted to the inside or outside of firewall or be floor/chassis mounted. See General Regulations 3:1.

STEERING

Aftermarket steering permitted. Steering column must retain stock appearance. Removable steering wheel permitted. Minimum steering-wheel diameter 11 inches. See General Regulations 3:3.

STEERING, FWD CONVERSIONS

May be relocated. Fabricated crossmember may be installed. Aftermarket steering permitted. See General Regulations 3:4.

SUSPENSION, FRONT

For FWD conversions, aftermarket or OEM front suspension of a stock configuration is required. Replacement control arms permitted. A full-tube chassis permitted, but must retain the as-built OEM upper framereils in front of firewall. The mounting point of replacement lower control arms may be non-OEM. The use of adjustable heim (or heim-type) joints permitted.

Any OEM or aftermarket shock absorber of a stock type permitted. Any OEM or aftermarket bushings are permitted. All other components (i.e., upper A-arms, springs, rods, fasteners, etc.) must be steel unless material similar to the original/stock components is used.

The struts must mount to the as-built upper OEM location. The strut lower tower may be modified (i.e., existing holes slotted or enlarged), but may not be reconfigured (i.e., welded shut). The strut mount may utilize an adapter or plate on the underside of the strut tower to facilitate camber/caster adjustment. Final strut installation must be in a manner such that removing the three bolts on top of the strut tower allows strut assembly removal.

Lift kits/travel limiters permitted. Sway bar optional.

RWD must retain complete OEM stock front-suspension system or may utilize generally available aftermarket steel front-suspension components (i.e., upper and lower control/A-arms, springs, fasteners, rods, etc. similar to the original/stock components. Mounting points must remain in original location. The use of adjustable heim (or heim-type) joints permitted. See General Regulations 3:4.

SUSPENSION, REAR

Any automotive rear suspension permitted.

FRAME: 4**BALLAST**

Maximum 100 pounds permitted in weight box. Additional ballast must be permanently attached to frame. Any item added

to car as a safety device must be for that specific purpose. Disguised ballast prohibited. See General Regulations 4:2.

BUMPERS

Complete stock bumpers, consistent with make, model, and year claimed, front and rear, mandatory. The front and rear bumpers must be attached to the chassis using the OEM impact bars. The bracing of the rear bumper can be reinforced by using aftermarket tubing and be attached to the rear frame section and body panels to retain exterior factory appearance. Inside front and rear bumpers must retain factory appearance. Covering of cavities prohibited.

Rear bumper cover only (i.e., not the bumper) may be notched or slotted for clearance around wheelie bars. Opening maximum is to allow for wheelie-bar movement only. Removal of rear bumper cover or trimming rear bumper cover the full width of wheelie bar permitted.

FRAME

Must be stock automobile frame for body used. Rear frame may be moderately relocated for tire clearance. Rear subframe may be constructed of 2-inch x 3-inch x 1/8-inch or 1 5/8-inch by .118-inch (mild steel) or .083-inch (chromoly) round tubing wall thickness and must be installed at original height. Crossmembers may be modified or fabricated only for transmission swaps, shock absorber and traction-bar installation. Front-to-rear frame-strengthening members may be added to any unibody-constructed car. May be up to 2-inch x 3-inch rectangular or 2 1/2-inch round material with .120-inch-maximum wall thickness and located in a straight line between front and rear subframes. If material passes through floor, floor must be welded to member, leaving no holes in floor.

FRAME, FWD CONVERSIONS

Aftermarket/fabricated forward-clip frame components of 2-inch x 3-inch x .083-inch wall steel or 2 1/2-inch O.D. x .120-wall steel maximum may be added to reinforce the as-built stock frame/support assembly. As-built OEM crossmembers may be relocated and/or trimmed for oil pan and/or engine clearance. The OEM engine cradle/lower (or inner) framerails may be retained, modified, or replaced.

ROLL CAGE

Mandatory. All chassis must meet the following SFI Spec: A/ SM through E/SM, A/SMA through E/SMA must meet SFI 25.1, 25.2, 25.3, 25.4, or 25.5 as applicable for e.t. and weight. Must conform to specs for body style used. See General Regulations 4:4, 4:11, 10:6.

ROLL-CAGE PADDING

Roll-cage padding meeting SFI Spec 45.1 mandatory anywhere driver's helmet may come in contact with roll-cage components. See General Regulations 4:11.

WHEELBASE

Must retain stock wheelbase +/- 3/4-inch and tread width for car body used. Minimum wheelbase 96 inches. Maximum variation from left to right: 1 inch.

TIRES & WHEELS: 5

TIRES

Slicks that fit in original outer wheelwell permitted. Inner wheelwells may be altered but must be completely finished. Outside of tire must be within 3 inches of inside of fender at widest point of fender. See FENDERS for restrictions. See General Regulations 5:1.

WHEELS

Aftermarket wheels may be used front and rear. Lightweight automotive-type wire wheels and motorcycle wheels prohibited. The front wheel must be mounted using an OEM configuration. Spindle-mount configurations prohibited. Minimum wheel size: 13 inches unless car was originally equipped with smaller wheels and is using original engine. See General Regulations 5:2.

INTERIOR: 6**DASH**

Dash must remain as-built OEM, but may be removable. Removable dash must be securely attached, and any non-factory fasteners must be concealed to retain factory appearance. Aftermarket or non-OEM dash prohibited.

UPHOLSTERY

Full interior trim must be retained according to factory specifications. Must have full factory-type upholstery, including factory-type carpet, door panels, and headliner. Interior gutting prohibited. Replacement door panels and headliner permitted, but must be fully upholstered to retain OEM appearance. Carpet must cover entire floor and any chassis/frame components in the floor area within the driver's compartment. Aftermarket front seats permitted, rear seat optional, but area must be reupholstered or carpeted (no bare panels). See General Regulations 6:2.

BODY: 7**BODY**

Must have factory-production 2-door sedan or hardtop passenger car body. Body must not be altered in height, width, length, or contour. Front overhang must retain stock dimension +/- 1 inch. Use of fiberglass restricted to hood (see HOOD). Other lightweight components prohibited. Cars must have fully operative mechanical door handles to permit entry/exit from either side. Raising body and/or frame to gain weight transfer prohibited. Rear rocker panel must not be higher than centerline of rear axle.

FENDERS

Front and rear fender may be opened for larger tires. Tire tread and wheel rim must be inside stock body or fender lines. Flaring or bulging fenders for wider tires prohibited. All opened or radiused fenders must be re-rolled. Inner fender panels may be relocated/trimmed on front-wheel-drive unibody vehicles from the front side of strut tower forward. Area may be enlarged for tire clearance, but must retain a finished, OEM appearance. See General Regulations 7:3.

FENDER SPLASH PANS

Mandatory in front. Can be trimmed to permit a maximum 2 inches clearance around headers. Shock absorbers or spring towers may not be altered.

FIREWALL

The lower portion of the OEM firewall may be replaced with steel of equal or greater thickness than OEM. Chevy Cavaliers, Pontiac Grand Ams and Sunfires, and Ford Escorts may replace or relocate the firewall, provided the measurement from the rear of the radiator core support to the firewall is 35 inches maximum. For Chevy Cobalt the radiator core support to the firewall is 34 inches maximum. For all others vehicles, firewall must be in the original location. A complete one-piece steel firewall that resembles OEM must be installed, welded in place, and sealed from the driver compartment. The firewall must extend to and attach to the floor. The firewall and mid-plate may be integral. See General Regulations 7:4.

FLOOR

Stock mandatory. Floor-mounted clutch/brake pedals permitted. A removable floor section for transmission/shifter installation is permitted, restricted to 6 square feet of minimum .032-inch aluminum or .024-inch steel. The removable floor section must fit and attach to the driveshaft tunnel, floor, and/or firewall such that it provides an adequate seal. The stock floor may be sectioned where rear frameraills have been narrowed. The area between the rear frameraills must be stock floor, in original location. Trunk may be replaced from four-link crossmember rearward. A driveshaft tunnel may be fabricated of same-as-floor material, and welded to the as-built OEM floor. The removable floor section and the driveshaft tunnel must present an OEM appearance; they may not be excessive in width, length, and/or height. All other floor material may be stock or replacement steel of equivalent thickness. The floor may be raised or lowered. The floor may be sectioned between the chassis/roll-cage components. Area from front spring mount of rear spring to rear of trunk may be sectioned in width to permit narrowing of rear frame. Cutting into stock floor for suspension members prohibited. Any protrusion in trunk may not be higher than top of stock frameraill. Cover must be made of materials of 14- to 20-gauge thickness. Headers must fit under stock floor location. The stock frameraills from the firewall to the radiator support must retain stock attachment configuration, stock location, and stock dimensions. Frame may be notched for header clearance. See General Regulations 7:5.

FLOORBOARDS

Stock with exception of shifter installations. Removable floor for transmission installation restricted to 6 square feet (2 x 3 feet, 1 x 6 feet, etc.) of steel or aluminum material identical to area removed. Floor from another car to replace area cut out is permitted.

For FWD conversion cars, a driveshaft tunnel may be fabricated of same-as-OEM floor material and must be fully welded to the as-built OEM floor.

GRILLE

Must be stock production for year, make, and model of body used.

HOOD

Mandatory. Fiberglass permitted. Carburetor(s) must be completely covered by hood, bubble, or scoop, which must be part of car hood, one opening only. Maximum of 11-inch scoop-opening height from adjacent hood surface. Tilt or removable front ends prohibited.

SPOILERS

Must be automotive production for body used. Complete package, front and rear, not required. Aftermarket rear spoiler permitted. Maximum length 10 inches as measured from deck lid to spoiler transition point to rear edge of spoiler. May be no wider than deck lid. Maximum height of spill plate, 4 inches. If aftermarket spoiler is used, any OEM spoilers must be removed.

STREET EQUIPMENT

Operative lighting system recommended. Electrically driven water pump and fan permitted. Cars originally produced with hideaway headlight units must maintain daylight appearance.

WHEELWELLS, REAR

Internal modifications only. Flaring or spreading of external fender lines prohibited. Radiusing permitted. Minimum drive wheel diameter, 14 inches, unless originally equipped with smaller wheels. If internal wheelwells are modified, outside of

tire must be within 3 inches of fender. Any material used to add to width of inner wheelwells must be steel or aluminum.

WINDSHIELD, WINDOWS

All windows, windshields, and backlight must be clear or factory-tinted safety glass and in good condition. Windows must be closed during competition. See General Regulations 7:8.

ELECTRICAL: 8

BATTERIES

Trunk installation permitted. Two batteries permitted. Maximum weight, wet and fully charged, including battery box: 100 pounds. See General Regulations 8:1, 8:3, 8:4.

INSTRUMENTS

Stock dashboard, including instruments, mandatory. Optional instruments (tachometer, pressure gauges, etc.) are permitted.

SUPPORT GROUP: 9

FIRE EXTINGUISHER SYSTEM

Permitted. See General Regulations 9:3.

DRIVER: 10

DRIVER

Must be in stock-type location; maximum 10-inch relocation from stock.

HELMET

For all cars, a full-face Snell M2010, M2015, SA2010, or SA2015 helmet mandatory; shield mandatory in cars 7.49 seconds or quicker (goggles prohibited). See General Regulations 10:7.

NECK COLLAR

Neck collar meeting SFI Spec 3.3 mandatory. See General Regulations 10:8.

PROTECTIVE CLOTHING

Jacket and pants meeting SFI Spec 3.2A/5 and gloves meeting SFI Spec 3.3/1 mandatory, except cars running 7.49 or quicker, jacket and pants or suit meeting SFI Spec 3.2A/15, gloves meeting SFI Spec 3.3/5, and boots or shoes meeting SFI Spec 3.3/5 mandatory. An SFI 3.3 head sock or SFI 3.3 skirted helmet is required on all cars 7.49 and quicker, where a neck collar is not used. See General Regulations 10:10.

SECTION 13H PRO MODIFIED

Requirements and specifications for Pro Modified classes are the same as those for Comp - Section 12 and Pro Mod - Section 5 with the following exceptions:

DESIGNATION

A/PM, AA/PM, preceded by car number.

CLASSES

A/PM: Naturally aspirated or nitrous-assisted entries

AA/PM: Supercharged (maximum 526 cid) or turbocharged



SECTION 14 TOP ALCOHOL DRAGSTER

DESIGNATION

TAD, preceded by car number.

Reserved for supercharged, methanol-burning and injected nitromethane/methanol-burning dragsters built specifically for drag racing competition. Cars are weighed at conclusion of run, including driver.

CLASS WEIGHT BREAKS

Non-supercharged single engine, nitromethane: 5.00 or more pounds per cubic inch weight break; minimum displacement 410 cubic inches; maximum displacement 456 cubic inches; 2,125 pounds minimum weight. 100 percent nitromethane permitted at events contested at Bandimere Speedway in Denver. Maximum nitromethane content 95 percent at all other events. All fuels other than nitromethane and methanol prohibited.

Supercharged, single engine, with Roots-type supercharger, methanol: maximum displacement 528 cubic inches; minimum weight 1,975 pounds.

Supercharged, single engine, with screw-type supercharger, methanol: maximum displacement 466 cubic inches; minimum weight 2,050 pounds. Competitors may continue to use larger engines by adding 5 pounds for each additional cubic inch to the stated minimum weight.

Any competitor who causes an oildown while participating at an NHRA Mello Yello event will be subject to fines and penalties as outlined in Section 2 - Oildown Penalties.

REQUIREMENTS & SPECIFICATIONS

ENGINE: 1

CYLINDER HEADS

Aftermarket billet heads permitted. Maximum two valves per cylinder; maximum two spark plugs per cylinder.

ENGINE

Any internal-combustion reciprocating, single-camshaft, automotive-type engine permitted. Maximum bore center spacing 4.840 inches. Dry-sump oil system permitted. OEM production line overhead cam engines permitted. Engine must be equipped with a lower-engine-ballistic/restraint device meeting SFI Spec 7.1. The lower-engine-ballistic/restraint

device must be specific for the oil pan and pump configuration being used and must fit according to the requirements of SFI Spec 7.1 and be used as appropriately designed for the specific application. A positive method (flange, lip, etc.) must be attached to the intake manifold or engine block to retain both the front and rear manifold to block gaskets in the event the engine crankcase/lifter valley become over-pressurized. The flange/lip must extend past the surface of the gasket and be contoured to closely fit the block and manifold surfaces to prevent the gasket(s) from extruding. All large (valve covers, intake manifolds, superchargers, headers, heads, blocks, etc.) and all moving engine components are restricted to aluminum, steel, iron, titanium, magnesium, or other conventional alloys; carbon fiber, Kevlar, ceramics, composites, beryllium, or other extraordinary materials prohibited. Metal, fiberglass, or carbon fiber injector hats and/or injector scoops are permitted.

Any modifications or alterations to engine blocks, cylinder heads, and engine components are deemed to be a change in design and therefore prohibited. This includes any redesign, reconfiguration, and/or modification to existing components. Refer any development, redesign, reconfiguration, and/or modification questions to the NHRA Technical Department to determine whether permitted or prohibited.

All permitted engine combinations must adhere to the following criteria:

1. Maintain interchangeability of existing parts (i.e., cranks, cams, manifolds, valve covers, rocker assemblies, etc.)
2. Maintain general combustion-chamber configuration (e.g., Hemi, canted valve). Fuel injection directly into cylinder prohibited
3. Maintain original cylinder orientation in reference to centerline of crankshaft
4. Retain cylinder head, timing cover, intake manifold, exhaust manifold, valve-cover bolt pattern; additional bolts/studs/dowels may be used
5. Retain as cast/forged minimum block wall and web/rib thickness

A current list of alcohol head specifications can be found on NHRARacer.com.

EXHAUST SYSTEM

Competition exhaust permitted. Exhaust must be directed to rear, away from driver and fuel tank.

FUEL SYSTEM

Fuel lines must be isolated from driver compartment by a subfloor or housing where engine is located in rear and fuel tank is in front of driver. Pressurized fuel tanks prohibited. Fuel tanks must be mounted above bottom framerail. Fuel cells permitted. Maximum two fuel pumps. EFI prohibited. The use of propylene oxide and/or nitrous oxide is prohibited. Minimum temperature of fuel in the staging lanes to the completion of the run and subsequent NHRA fuel check is 50 degrees F. A failure to pass the minimum fuel-temperature check in the staging lanes prior to a run will result in the forfeiture of that run, and the racer must return to the racer's pit. A failure to pass the minimum fuel-temperature check after a run will cause that run to be disqualified. Insulated fuel tanks permitted. Insulation is permitted on the main fuel line only from the fuel tank to the fuel pump. Temporary one-piece flexible blanket-type material, maximum 1 inch thick, that wraps one time around the outside

of the body panels in the vicinity of the fuel tank permitted. The wrap must be quick release and require no additional work on the body or any tools to remove and be no more than 12 inches longer than the fuel tank. Any temporary insulation must be removed prior to and without delaying the starting of the engine. Fuel gauge lines in the driver's compartment must be steel or steel braided with steel fittings. Flexible gauge lines in the driver's compartment must be hydrostatically pressure tested at 750 psi for 30 seconds and labeled. Label must be impervious to fuel and brake cleaner. See General Regulations 1:5 and 1:6. Note: Non-supercharged single engine, nitromethane dragsters must follow all of the rules in the Fuel System section with the following exceptions: 1. Minimum temperature of fuel in the staging lanes to the completion of the run and subsequent NHRA fuel check is 40 degrees F. A failure to pass the minimum fuel-temperature check in the staging lanes prior to a run will result in the forfeiture of that run, and the racer must return to the racer's pit. A failure to pass the minimum fuel-temperature check after a run will cause that run to be disqualified.

INJECTOR SCOOP

Maximum injector scoop opening of 1 square foot, with top of opening no higher than 24 inches above the top of roll cage. Scoop may not extend more than 18 inches forward of the center of the forward engine cylinder, may not extend more than 12 inches behind the center of the rear engine cylinder, and may not exceed 24 inches in width.

OIL LINES

All flexible-pressure oil lines, excluding return lines and any line 30psi or lower in pressure, must use a factory-crimped connection and be pressure-tested and labeled. All testing must be hydrostatic for minimum 30 seconds at 750psi. Label must indicate date, PSI, and tester ID. Labeling must be impervious to fuel and brake clean. Quick disconnect, plastic, and nylon lines are prohibited. The lines must be tested and tagged to indicate that they have been tested within two years. Test and tag services are available at national events. All of the lines must be routed in such a way that they are not directly in line with cylinder head gaskets at the front, rear, or side of the cylinder heads.

OIL-RETENTION DEVICE

Engine oil-retention pan mandatory. Minimum material, .050-inch aluminum or .040-inch carbon fiber/Kevlar. Pan must extend forward a minimum of one inch from the front face of the lower pulley and may not extend rearward more than 6 inches beyond the rear-end housing. Pan may be no wider than outside edge of the bottom framerails and must extend to the top of the upper framerails. Pan must be either a one-piece design or constructed as to be sealed as a retention device to retain oil. Must have minimum four-inch-high bulkheads for oil retention during acceleration and deceleration. Front bulkhead must be forward a minimum one inch of the lower blower pulley, and rear bulkhead must be behind the rear of the bellhousing. Bulkheads must be "coved" toward oil pan to assist oil in staying within the confines of the bulkheads. A nonflammable, oil-absorbent liner mandatory inside of retention device. Minimum number of slots or holes in the walls to clear frame, steering, or lines permitted.

SUPERCHARGER

Roots-type maximum size: 14-71, 22 1/4-inch case length, 11 1/4-inch case width, 19-inch rotor length; maximum rotor diameter: 5.840 inches including fixed stripping. The case must be one piece with removable front and rear bearing end plates; rotor must be contained within one-piece case. Helix is restricted to a maximum rotor spiral of 6.5 degrees per inch of

rotor length. Manifold burst panel meeting SFI Spec 23.1 plus restraint system meeting SFI Spec 14.2 mandatory. The rotors must be driven from the front (both the external drive and the internal gearing). The entire inlet opening must be on/in the upper surface only. Any inlet/outlet cavity in front of the rotors is restricted to maximum 2.150 inches, measuring from the face of bearing plate to the back of the cavity. Billet cases prohibited. The maximum length from the front of the supercharger drive pulley to the leading edge of the rotor is 15 inches. The use of spacers, modified cases, offset drive pulleys, or attaching methods to move the supercharger rearward in excess of the specified amount is prohibited. All manifold configurations and supercharger modifications and locations must be accepted prior to competition. Variable multispeed supercharger devices prohibited. Supercharger must be in conventional location above the intake manifold and cylinder heads, and supercharger restraint device may not be modified. Placement of any object/device below the upper mating surface of the supercharger intended to alter air flow characteristics is prohibited (e.g. inserts/shoes, dividers, etc.).

Screw-type superchargers must meet SFI Spec 34.1 and be reinspected by the manufacturer every three years. Manifold burst panel meeting SFI Spec 23.1 (in addition to panel in supercharger) plus restraint system meeting SFI Spec 14.21 mandatory. Billet cases prohibited. Supercharger restraint straps must be covered with a fire-resistant material. The blower restraint straps and fuel lines must be installed such that when the restraint straps are fully extended no load is placed on any of the fuel lines.

Maximum overdrive limits are 2.28 PSI and 1.70 Roots. Variable multi-speed supercharger devices prohibited. Turbocharger(s) prohibited. See General Regulations 1:10, 1:11.

THROTTLE

Throttle-actuating method on rear-engine cars must be protected where it passes blower drive. Throttle control must be manually operated by driver's foot: Electronics, pneumatics, hydraulics, or any other device may in no way affect the throttle operation. Dual throttle springs, one on each end of all injector throttle shafts that extend through both ends of the injector body, mandatory. A mechanical device for controlling engine rpm during burnouts may be attached to the injector or throttle linkage but may not be driver-controlled. See General Regulations 1:12.

VALVE COVERS

Cast or fabricated metal valve covers using all attachment bolt holes mandatory. Valve-cover restraints meeting SFI Spec 14.4 mandatory on all non-supercharged, nitromethane-burning engines. Valve-cover gaskets, O-rings, etc. must be completely bonded/glued to either the valve cover or cylinder head sealing surface. Vent tube adapters on the valve covers must either be fully welded to the valve covers or incorporate a gasket or O-ring that is bonded/glued to either the adapter or the valve cover. Valve covers must be fastened to the cylinder heads with studs and nuts in lieu of bolts where possible. Spark-plug tubes that penetrate the valve covers must have a restraining device to contain the spark-plug tube in the valve cover in the event the spark plug is discharged.

VENT TUBE BREATHERS

NHRA-accepted catch can/vent tube system mandatory. Twist-on/quick-disconnect fittings between the vent tube hoses and the valve cover vent tube adapters must incorporate a

secondary locking device such as a hasp pin, ball lock pin, etc. Tape is not a satisfactory primary or secondary locking device. Double clamps are required on each end of all hoses used in the vent system, including the dry-sump vents. Double O rings required at each breather hose to valve cover attachment. Minimum 1 1/4-inch inside diameter hoses are required from each valve cover to the catch can inlets and/or framerails and from each framerail outlet to both catch can inlets. Minimum catch can(s) capacity is 6.75 gallons. Catch cans must have adequate internal baffling. Minimum catch can inlet configuration is two 1 1/8-inch inside diameter (or equivalent area) tubes. Minimum catch can outlet/discharge configuration is two 1 1/8-inch inside diameter openings (or equivalent area). NHRA-accepted vent tubes/hoses are mandatory for all connections; see NHRARacer.com for a list of accepted vent tubes/hoses. Vent tubes must be unobstructed from the interior of the valve cover to the interior of the catch can; i.e., no orifices, reduced areas, filler materials, etc. Pan/crankcase vacuum systems, of any description, are prohibited. See General Regulations 1:13.

DRIVETRAIN: 2

CLUTCH, FLYWHEEL, FLYWHEEL SHIELD

Flywheel and clutch meeting SFI Spec 1.3 or 1.4 and flywheel shield meeting SFI Spec 6.2 mandatory on all cars. Three discs maximum on supercharged, methanol-burning cars. Four discs maximum on injected nitromethane cars. Maximum depth of flywheel shield: 9.4 inches (inside). Clutch must be manually operated by driver's foot: Electronics, pneumatics, hydraulics, or any other device may in no way affect the clutch system. Throwout bearing must release all fingers, levers, stages, etc. simultaneously. Staged or variable release clutches of any description prohibited. Clutch/bellhousing exhaust filter mandatory. See General Regulations 2:3, 2:5, 2:6, 2:8.

DRIVELINE

Anti-blowback device mandatory. See General Regulations 2:1.

REAR END

Aftermarket full-floating or live axle assembly mandatory. Maximum (numeric) gear ratio 4.58 for big-block, screw-supercharger-equipped cars; 4.72 for big-block, Roots-supercharger-equipped cars; 4.90 for small-block car regardless of supercharger. Minimum (numeric) gear ratio, 2.90 for non-supercharged, nitromethane-burning cars. See General Regulations 2:11.

TRANSMISSION

Transmission prohibited in non-supercharged, nitromethane-burning class. OEM or OEM-modified transmissions prohibited in all classes. Aftermarket planetary transmission permitted in supercharged classes, limited to two units (three speeds). Lockup converters prohibited. Overdrive transmission prohibited. Final drive ratio must be 1:1. Clutch hold-down device recommended on all cars. Reverser mandatory. Automated shifters and/or timer-type shifting devices prohibited; each individual shift must be a function of the driver. Air shifter bottles must be stamped as meeting DOT-1800 pound rating and permanently mounted (hose clamps or tie wraps prohibited).

For the supercharged-methanol combinations only, the use of a transmission consisting of an aftermarket torque converter and an aftermarket planetary transmission (three-speed maximum) with an electric-only transbrake is permitted. The unit must be NHRA-accepted. Contact NHRA Technical Services for

accepted list. The use of a delay box/device is prohibited. An aftermarket SFI 29.1 flexplate (with no starter ring gear) or a solid-steel converter driveplate, an SFI 6.1, 6.2, or 6.3 flywheel shield, and an aftermarket SFI 4.1 one-piece transmission shield (covering the transmission units and the reverser) are required.

TRANSMISSION SHIELD

A one-piece ballistic shield covering all units mandatory. Must meet SFI Spec 4.1. See General Regulations 2:13.

BRAKES & SUSPENSION: 3

BRAKES

Automated brakes prohibited: Application and release of brakes must be a function of the driver. Dual spots or equivalent oval pucks mandatory; minimum two rear-wheel hydraulic disc brakes. Carbon-fiber brake rotors used in conjunction with carbon-fiber specific brake pads mandatory; all other materials prohibited. Hand brake, if used, must be located inside body or driver compartment. Steel brake lines mandatory. NHRA-accepted fireproof brake line covering mandatory on all flexible connection lines. A current list of NHRA-accepted fireproof brake line coverings is available on NHRARacer.com. Brake lines passing engine or blower drive must be shielded. Hand-brake handle must be constructed of minimum 5/16-inch-thick by 1-inch-wide aluminum, steel, or titanium. Lightening of hand-brake handle (i.e., holes, machining, etc.) prohibited. See General Regulations 3:1.

STEERING

Commercially available quick-disconnect steering wheel meeting SFI Spec 42.1 or removable (via quick-release pins) steering box crossmember mandatory. Use of a pinned steering crossmember in lieu of an SFI quick-disconnect steering wheel prohibited on front-engine cars. A device must be used to prevent a long steering shaft from injuring driver in case of frontal impact. Plating of steering components prohibited on all cars. See General Regulations 3:3.

SUSPENSION

Front suspension optional. Plating of front suspension components prohibited on all cars. See General Regulations 3:4.

WHEELIE BARS

Mandatory; must be functional. Maximum height 4 inches measured from racing surface to bottom of wheel. Wheels must be nonmetallic. See General Regulations 3:6.

FRAME: 4

BALLAST

Permitted. Maximum total ballast (welded or bolted), 250 pounds. See General Regulations 4:2.

HELMET SHROUD/DEFLECTOR PLATE

All vehicles in Top Alcohol Dragster must have a rear roll-cage shroud. A one-, two-, or three-piece shroud is acceptable. The shroud must be constructed of minimum .075-inch Grade 2 ASTM-B-265 titanium or .090-inch 4130 steel and must be shaped to conform to the roll cage. The shroud must be attached to each of the side bars with a minimum of three 5/16-inch Grade 8 bolts and bosses per side, to the top with one 5/16-inch Grade 8 bolt and boss, and to the rear bars with a minimum of two 5/16-inch Grade 8 bolts and bosses per side. Bolt heads must be 1/2-inch hex-style head. Tabs with bolt and nut, where the nut is welded to the tab, may be used in place of the bosses.

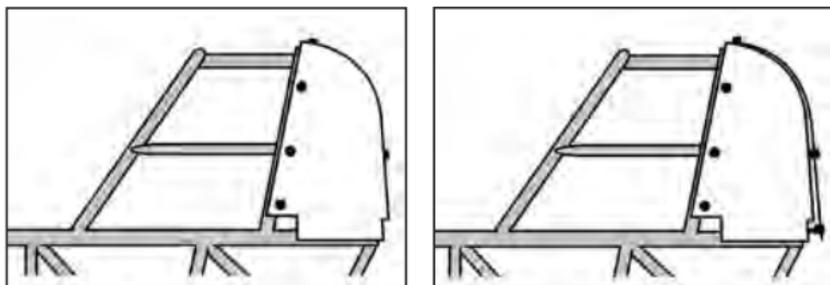

NHRA-accepted helmet shrouds must be made as a one-piece shroud, a two-piece shroud, where each half must overlap; or a three-piece shroud, that includes two side shields and the center section.

All shrouds must fully encapsulate the rear braces and the secondary roll-cage hoop on the sides and top; when viewed from the rear, the shroud must cover the complete visible roll-cage structure. On the bottom, the entire shroud must extend fully down to the centerline of the shoulder hoop; on the top and sides, the entire shroud must extend fully forward to at least the centerline of the side bars.

When the shroud is fabricated as a two-piece unit, the components must overlap a minimum of 3/4-inch per side.

On a three-piece shroud, the center/rear section of the shroud may stand off from/behind the side pieces by no more than 3/4 inches at any point and must overlap each side a minimum of 1 1/2 inches. The side shrouds must extend to the centerline of the rear hoops.

The shroud must be installed flush with or be filled/sealed to the upper roll-cage bars and shoulder hoop so that protective equipment cannot catch between the shroud and the roll-cage components. Absolutely no components may be mounted to the helmet shroud or deflector plate above the top of the shoulder hoop.

A deflector plate, minimum 1/8-inch 6061 T6 aluminum or 1/16-inch steel or titanium, must be installed between roll cage and engine. The deflector plate must extend from 1 inch above top blower pulley to 1 inch below bottom pulley and be a minimum 10 inches wide from shoulder bar to highest point. On any enclosed engine/driver configuration, a full bulkhead must be installed to completely seal driver from the engine. Minimum attachment for any plate is four 5/16-inch Grade 8 bolts. See General Regulations 4:3.

All deflector plates must be stamped by manufacturer of the bulkhead to certify that the proper material was used. The stamp must be in a location for easy inspection.

GROUND CLEARANCE

Minimum 3 inches from front of car to 12 inches behind centerline of front axle, 2 inches for remainder of car, except oil pan.

PARACHUTE

Dual parachutes mandatory. Two separate shroud line mounting points mandatory with sleeved 1/2-inch-minimum grade 8 steel bolts with self-locking nuts or with nuts welded onto parachute brackets. Shroud line mounting brackets must be constructed of minimum 3/16-inch 4130 steel. Two NHRA-accepted parachute tethers are required and must be routed through each shroud

line end loop and be attached using the rear end mounting bolts on each side. The mounting attachments on each end of both tethers must attach to either separate rear end mounting bolts or opposite ends of a single bolt (one under the head of the bolt and the other under the nut). NHRA-accepted parachute tethers: Amick Race Car Restraints PARA-101REV1, Future Fibres FF30MLB-P-MB, or Taylor Motorsports 108. When Future Fibres FF30MLB-P-MB is used, only one tether is required and must be routed through each shroud line end loop and be attached using the rear end mounting bolt on each side. All tethers must be covered with a fire-resistant material. See REAR WINGS & SUPPORTS. See General Regulations 4:8.

ROLL CAGE

Chassis must meet SFI Spec 2.1 (rear-engine cars), 10.1 (front-engine, driver in front of rear end) or SFI Spec 2.2 (front-engine, driver behind rear end). Chassis must be recertified yearly by NHRA and have serialized sticker affixed to frame before participation. All wiring must be external of the framrails; routing of cables, hydraulic, or pneumatic lines inside the chassis is permitted. See General Regulations 4:4, 4:11, 10:6.

ROLL-CAGE PADDING

Roll-cage padding meeting SFI Spec 45.1 mandatory where driver's helmet may come in contact with roll-cage components. Additional padding mounted on flat stock and fastened to the roll cage on both sides of the driver's helmet, mandatory. Additional padding must be NHRA-accepted (with manufacturer's name displayed), securely mounted using bolts or locking fasteners, and must include a flame-retardant covering. A current list of NHRA-accepted lateral head supports is available on NHRARacer.com. See General Regulations 4:11.

WHEELBASE & FRONT TREAD WIDTH

Minimum 150 inches; maximum 300 inches on long side. Maximum wheelbase variation from left to right: 2 inches. Minimum front tread width 26 inches.

TIRES & WHEELS: 5

TIRES

Tires must be specified for racing use by manufacturer. Maximum rear tire: 18 inches wide x 118 inches maximum circumference. Minimum rear tire circumference: 108 inches. Tires are to meet size requirements when installed and ready to run at manufacturer's recommended operating pressures. Minimum diameter of 13 inches on front tires for dragsters. See General Regulations 5:1.

WHEELS

Rear wheels meeting SFI Spec 15.1 mandatory; maximum width: 16 inches. Wire wheels prohibited. Rear-wheel discs or covers prohibited. Use of a liner mandatory on non-beadlock wheels. See General Regulations 5:2.

INTERIOR: 6

SEAT

Seats must be foamed with energy-absorbing material and formed to the driver's body. Minimum one-layer, flame-retardant material mandatory as seat upholstery. No magnesium permitted.

BODY: 7

FRONT AIRFOIL/WING

Positive locking device to prevent movement mandatory. Minimum fastener size on all front wings, canards, etc., 1/4-inch; ball lock pins prohibited.

BODY

Body and cowl must be metal, carbon fiber, or fiberglass. Driver compartment, frame structure, roll bars, and body must be designed to prevent driver's body or limbs from contact with track surface. Subflooring, inside but independent of body, mandatory where driver's legs rest on belly pan or chassis. Front overhang not to exceed 30 inches, measured from centerline of front spindle to forwardmost point of car.

Enclosed driver's compartment (canopy) prohibited. Ground effects of any description prohibited. Ground effects include but are not limited to rocker skirts, belly pans, sheet metal work under the body that produces a "tunnel" for the passage of air, etc. Air deflector plates located behind cockpit restricted to maximum 17 inches by 17 inches. Leading edges, fairing in or rounding off corners, etc. prohibited. Maximum 1.25-inch lip for stiffening permitted. Deflector plate may be located in front of or behind exhaust headers.

FRONT-WHEEL FAIRINGS

Prohibited.

WINDSCREEN

Mandatory. See General Regulations 7:7.

REAR WINGS & SUPPORTS

All rear wing supports must meet SFI Spec 2.1. Wing configuration limited to one only, with maximum three elements. Combined total area of rear wing (total of all stages and/or elements) is restricted to 550 square inches minimum, 1,500 square inches maximum. Trailing edge of rear wing may not extend more than 50 inches behind centerline of rear axle. Maximum height of any wing as measured vertically from the trailing edge of wing to ground is 90 inches. Strut mounting points may not be forward of motor plate. No part of wing to be within 6 inches of rear tire. Any adjustment or movement during run prohibited. Pressurization of wing struts, up to a maximum of 200psi, permitted.

Spill plates must be flat, vertical, and parallel. Maximum thickness, 3/8-inch. Spill plate lips of any kind, other than a 1/4-inch maximum wicker, prohibited. Spill plate must attach to wing or airfoil at right angle, radius at joint prohibited. Maximum spill-plate dimensions, 22 inches by 22 inches.

For all cars, an independent cable must be wrapped around each side of the main element of the rear wing and be connected to both parachute release cables such that if the main element separates from the support or if either end of the main element is broken off, both parachutes will automatically deploy. The cables must be wrapped around the main element on the outside of the support structure and be secured (i.e., taped, hardwired, etc.) to the main element to keep the cables from sliding on the wing. The outermost connections of this cable to the wing should be no more than 2 inches from each spill plate. Attachment to spill plate permitted.

ELECTRICAL: 8**ELECTRICAL COMPONENTS**

Electrical and electronic components are restricted to ignition systems, data recorders, electrical gauges or indicators, automated fire extinguisher, and engine shutoff system components only. The use of electrical/electronic timers to control pneumatic fuel-system valves and/or electric fuel control solenoid valves is permitted. The fuel control system may use only movement of the throttle or clutch pedal, a transmission

shift, electric/electronic timers, and/or an engine rpm switch to control the fuel-system valves and/or to start the timers that control the fuel-system valves.

IGNITION

Programmable ignition permitted. Only preset times, throttle position, engine rpm, other internal engine data (temperatures, flow rates, and pressures), and transmission shifts may be processed with regard to control of the ignition system. Any ignition system that incorporates any programmable multi-point rev limiter and/or any rate-of-acceleration rpm limiter in any form is prohibited. Any ignition system that incorporates vehicle performance data via measurement, sensing, processing, inference, etc. to activate or deactivate any function or capability of the ignition system is prohibited. Any sensor or wiring that connects or transmits vehicle performance data directly, or indirectly, to the ignition system is prohibited. Ignition system components must be utilized in an unaltered manner consistent with the manufacturer's installation and instruction manuals unless otherwise approved. The use of any automated rpm-control device during the staging/launching process is permitted only in vehicles with a fully automatic transmission with a converter. See General Regulations 8:3.

IGNITION SYSTEM

All microprocessor ignition components prohibited. See General Regulations 8:3.

MAGNETOS

Maximum two magnetos; two spark plugs per cylinder, not to exceed 44 amps per magneto. Magnetos limited to the following models: MSD Pro Mag Systems, 12 or 20 amp, 8109, 8139, 8149, 7908, 7910, 7915, 7916, 8150, 8160; MSD Pro Mag Systems, 44 amp, 8130, 8140; Mallory Super Mag Series 3, 4, 6, 7, 11.

SUPPORT GROUP: 9

COMPUTER/DATA RECORDERS

See General Regulations 9:1, 9:2.

FIRE EXTINGUISHER SYSTEM

Fire extinguisher system meeting SFI Spec 17.1 mandatory when driver sits behind engine(s). Must be installed per manufacturer's specifications with all gauges clearly visible. See General Regulations 9:3 for acceptable fire extinguishing agents.

SHUTOFF DEVICE

Properly installed and operational Electrimotion Top Alcohol Dragster Shutoff Controller Kit (part number SB001TAD for blown applications, SB001AFD for injected nitro applications) and Electrimotion Shutoff Receiver (part number RF001) mandatory. The Electrimotion Top Alcohol Dragster Safety Shutoff Controller Kit must be properly installed per the manufacturer's instructions. Modification of or tampering with the Electrimotion Top Alcohol Dragster Safety Shutoff Controller Kit prohibited.

TOW VEHICLES

Permitted. See General Regulations 9:12.

WARM-UPS

See General Regulations 9:5, 9:14.

DRIVER: 10

ARM RESTRAINTS

Mandatory. See General Regulations 10:3.

CREDENTIALS

Valid NHRA competition license mandatory. All competitors at

NHRA Mello Yello national events must be a minimum of 18 years of age. See General Regulations 10:4.

DRIVER RESTRAINT SYSTEM

All belts must be covered with a fire-resistant covering. Minimum 6-point driver restraint system meeting SFI Spec 16.1 mandatory. All shoulder, lap, and leg straps may be wrapped around a frame or chassis tube, provided the belt is properly aligned toward the direction of pull. When fastened with driver in position, absolutely no “folds” are permitted in any belt(s). Otherwise, all belts must be mounted to the chassis via mounting brackets that are bolted or welded to the chassis per the manufacturer’s instructions. If the bracket is bolted through framerail or chassis tube, the hole in framerail or chassis tube must be bushed, with both ends of the bushing completely welded to the tube. Whether mounted directly to frame or to a tab welded to the frame, the mounting bracket attachment bolt must be in double shear and of shoulder bolt design so as to permit the bracket to pivot and align toward the direction of pull. Shoulder belts may utilize two individual straps, each with its own mount and mounting point; for a single strap, it must wrap a minimum of 540 degrees around the shoulder hoop.

HEAD AND NECK RESTRAINT DEVICE/SYSTEM

At all times that the driver is in the race vehicle, from the ready line until the vehicle is on the return road, driver must properly utilize an SFI-approved head and neck restraint device/system, including connecting the helmet as required for full functionality of the device. The device/system must meet SFI Spec 38.1 and must display a valid SFI label. The head and neck restraint device/system, when connected, must conform to the manufacturer’s mounting instructions, and it must be configured, maintained, and used in accordance with the manufacturer’s instructions.

HELMET

For all cars, a full-face Snell SA2010 or SA2015 helmet and shield mandatory (goggles prohibited). Eject Helmet Removal System (part number SDR 890-01-30) mandatory and must be installed per manufacturer instructions. A Stand 21 Lid Lifter head sock meeting SFI 3.3 may be used in lieu of the Eject Helmet Removal System. See General Regulations 10:7.

PROTECTIVE CLOTHING

Driver’s suit meeting SFI Spec 3.2A/15, gloves 3.3/15, boots/shoes 3.3/15, and head sock 3.3 mandatory. Drivers of supercharged front-engine cars must use suit meeting SFI Spec 3.2A/20, gloves 3.3/20, boots 3.3/20, and head sock 3.3 mandatory. All jacket and pants or driver suit that meet the SFI Spec 3.2A/15 or 3.2A/20 must be recertified on a five-year interval. Head sock is not mandatory when helmet is manufactured with a skirt labeled as meeting SFI Spec. 3.3. See General Regulations 10:10.



SECTION 15 TOP ALCOHOL FUNNY CAR

Requirements and specifications for Top Alcohol Funny Car are the same as those for Top Alcohol Dragster - Section 13 - with the following exceptions:

DESIGNATION

TAFC, preceded by car number.

Reserved for alcohol-burning Funny Cars built specifically for drag racing competition. Cars are weighed at the conclusion of a run, including driver.

Supercharged with screw-type supercharger, methanol: 2,300 pounds minimum weight.

Supercharged with Roots-type supercharger, methanol: 2,200 pounds minimum weight.

REQUIREMENTS & SPECIFICATIONS

ENGINE: 1

ENGINE

Maximum 528-cid for screw-type-supercharger-equipped cars; maximum 565-cid for Roots-type-supercharger-equipped cars.

EXHAUST

Double pipe insulated exhaust headers mandatory. Double tube must extend to start of bend at bottom of body.

FUEL SYSTEM

Fuel cells recommended. EFI prohibited. Pressurized fuel tanks prohibited. Tanks must be vented outside of body lines to prevent fire from being drawn into tank through vent. Fuel tank vent, maximum 1-inch-diameter hole in front of body to vent fuel tank outside of body only. A failure to pass the minimum fuel-temperature check in the staging lanes prior to a run will result in the forfeiture of that run, and the racer must return to the racer's pit. A failure to pass the minimum fuel-temperature check after a run will cause that run to be disqualified. Outside of the pit area, insulated fuel lines and tanks prohibited with the exception of a temporary one-piece flexible blanket-type material, maximum 1 inch thick, that wraps one time around the outside of the body panels in the vicinity of the fuel tank. The wrap must be quick release and require no additional work on

the body or any tools to remove and be no more than 12 inches longer than the fuel tank. Any temporary insulation must be removed prior to and without delaying the starting of the engine. Maximum two fuel pumps. The use of propylene oxide and/or nitrous oxide is prohibited. Insulated fuel lines and fuel tanks prohibited. Minimum temperature of fuel in the staging lanes to the completion of the run and subsequent NHRA fuel check is 50°F. See General Regulations 1:5.

HEADERS

Minimum Funny Car header angle 32 degrees. Maximum header pipe O.D. 2.75 inches. O.D. and I.D. must remain constant beginning 8 inches below the header flange to the exit of the header.

INJECTOR SCOOP

Injector scoop may not extend more than 18 inches forward of the center of the forward engine cylinder, may not extend more than 12 inches behind the center of the rear engine cylinder, may not be higher than the top of the windshield, may not have more than 1 square foot of opening area, and may not be more than 24 inches wide.

OIL-RETENTION DEVICE

Engine oil-retention device mandatory. Minimum material, .050-inch aluminum or .040-inch carbon fiber/Kevlar. Pan must extend forward a minimum of one inch from the front face of the lower pulley and may not extend rearward past the crossmember under the pinion flange. Pan may be no wider than outside edge of the bottom framerails and must extend to the top of the upper framerails. Pan must be either a one-piece design or constructed as to be sealed as a retention device to retain oil. Must have minimum four-inch-high bulkheads for oil retention during acceleration and deceleration. Front bulkhead must be forward a minimum one inch of the lower blower pulley, and rear bulkhead must be behind the rear of the bellhousing. Bulkheads must be "coved" toward oil pan to assist oil in staying within the confines of the bulkheads. A nonflammable, oil-absorbent liner mandatory inside of retention device. Minimum number of slots or holes in the walls to clear frame, steering, or lines permitted.

SUPERCHARGER

Maximum overdrive limits are 1.92 PSI and 1.70 Roots. Placement of any object/device below the upper mating surface of the supercharger intended to alter air flow characteristics is prohibited (e.g. inserts/shoes, dividers, etc.).

Cars with a supercharger/intake manifold burst panel in the rear must have a .024-inch steel, or .032-inch aluminum ducting, or carbon fiber ducting lined with an NHRA-accepted flame-retardant covering or coating, 4-inch minimum diameter, installed to relieve burst pressure from the burst panel(s) vicinity through the firewall and out the side window.

VENT TUBE BREATHERS

Catch can/vent tube system mandatory. Twist-on/quick-disconnect fittings between the vent tube hoses and the valve cover vent tube adapters must incorporate a secondary locking device such as a hasp pin; ball lock pin prohibited. Tape is not a satisfactory primary or secondary locking device. Double clamps are required on each end of all hoses used in the vent system, including the dry-sump vents. Minimum 1 1/4-inch inside diameter hoses are required from each valve cover to the catch can inlets and/or framerails and from each framerail outlet to both catch can inlets. Minimum catch can(s) capacity is a 1-gallon sump (i.e., below the bottom baffle) when the valve cover discharges are routed through the upper framerails;

otherwise, a 2-gallon sump capacity is mandatory. Minimum catch can inlet and outlet/discharge configuration is two 1 1/8-inch inside diameter openings (or equivalent area). NHRA-accepted vent tubes/hoses are mandatory for all connections; see NHRARacer.com for a list of accepted vent tubes/hoses. Vent tubes must be unobstructed from the interior of the valve cover to the interior of the catch can; i.e., no orifices, reduced areas, filler materials, etc. Pan/crankcase vacuum systems, of any description, are prohibited. See General Regulations 1:13.

DRIVETRAIN: 2

DRIVELINE COVER

Each end of driveshaft must have a full 360-degree cover of minimum 1/16-inch steel or 1/8-inch aluminum. Rear cover must surround the coupler. Front cover must surround the driveshaft from the back of the reverser to the end of the splicer sleeve in the area of the driver's legs. All covers must be securely mounted to frame, suitable crossmember, reverser, or third member.

REAR END

Aftermarket full-floating or live axle assembly mandatory. Maximum (numeric) gear ratio 4.30 for screw-type-supercharger-equipped cars, 4.58 for Roots-type-supercharger-equipped cars. See General Regulations 2:11.

TRANSMISSION

Transmission limited to two units (three forward speeds). Lockup converters prohibited.

BRAKES & SUSPENSION: 3

BRAKES

Four-wheel disc brakes with dual master cylinder mandatory. Carbon-fiber brake rotors used in conjunction with carbon-fiber specific brake pads (front and rear) mandatory; all other materials prohibited. NHRA-accepted fireproof brake line covering mandatory on all (front and rear) flexible connection lines. A current list of NHRA-accepted fireproof brake line coverings is available on NHRARacer.com. Hand-brake handle must be constructed of minimum 5/16-inch-thick by 1-inch-wide aluminum, steel, or titanium. Lightening of hand-brake handle (i.e., holes, machining, etc.) prohibited.

STEERING

Plating of steering components prohibited on all cars.

SUSPENSION

Plating of front suspension components prohibited on all cars.

FRAME: 4

HELMET SHROUD/DEFLECTOR PLATE

All vehicles in Top Alcohol Funny Car must have a rear roll-cage shroud. A multipiece shroud is permitted. The shroud must be constructed of minimum .075-inch Grade 2 ASTM-B-265 titanium or .090-inch 4130 steel or be of NHRA-accepted composite construction and must be shaped to conform to the roll cage. The shroud must be attached to each of the side bars with a minimum of three 1/4-inch-minimum-diameter Grade 8 bolts and bosses per side, to the top with one 1/4-inch-minimum-diameter Grade 8 bolt and boss, and to the rear bars with a minimum of two 1/4-inch-minimum-diameter Grade 8 bolts and bosses per side. Tabs with bolt and nut, where the nut is welded to the tab, may be used in place of the bosses. Three-piece shields must be made with two side shields and a center section.

The shroud must be installed flush with or be filled/sealed to

the upper roll-cage bars and shoulder hoop so that protective equipment cannot catch between the shroud and the roll-cage components. Absolutely no components may be mounted to the helmet shroud above the top of the shoulder hoop. Bolt heads must be 1/2-inch hex-style head.

PARACHUTE

Dual parachutes mandatory. Two separate shroud line mounting points mandatory with sleeved 1/2-inch-minimum Grade 8 steel bolts with self-locking nuts or with nuts welded onto parachute brackets. Shroud line mounting brackets must be constructed of minimum 3/16-inch 4130 steel. Two NHRA-accepted parachute tethers are required and must be routed through each shroud line end loop and be attached using the rear end mounting bolts on each side. The mounting attachments on each end of both tethers must attach to either separate rear end mounting bolts or opposite ends of a single bolt (one under the head of the bolt and the other under the nut). NHRA-accepted parachute tethers: Amick Race Car Restraints PARA-101REV1, Future Fibres FF30MLB-P-MB, or Taylor Motorsports 108. When Future Fibres FF30MLB-P-MB is used, only one tether is required and must be routed through each shroud line end loop and be attached using the rear end mounting bolt on each side. All tethers must be covered with a fire-resistant material. The parachute floor must be flat and may not extend more than 6 inches rearward or beyond the parachute pack, whichever is less. The measurement will be taken from the mounting point on the rear of the body. The use of a wicker prohibited. See General Regulations 4:8.

ROLL CAGE

Chassis must meet SFI Spec 10.1. All wiring must be external of the framerails; routing of cables, hydraulic, or pneumatic lines inside the chassis is permitted. Chassis must be recertified yearly by NHRA and have serialized sticker affixed to frame before participation. See General Regulations 4:4, 4:11, 10:6.

ROLL-CAGE PADDING

Roll-cage padding meeting SFI Spec 45.1 mandatory where driver's helmet may come in contact with roll-cage components. Additional padding mounted on flat stock and fastened to the roll cage on both sides of the driver's helmet, mandatory. Additional padding must be NHRA-accepted (with manufacturer's name displayed), securely mounted using bolts or locking fasteners, and must include a flame-retardant covering. A current list of NHRA-accepted lateral head supports is available on NHRARacer.com. See General Regulations 4:11.

WHEELBASE

Minimum 100 inches; maximum 125 inches on long side. Maximum wheelbase variation from left to right: 2 inches. Rear tread width cannot be outside of body line nor more than 3 inches inside body line. Front tread width must be no more than 6 inches inside body line. Measurements will be taken from outside edge of tire to inside edge of body.

TOW-STRAP HOOPS

All cars must have tow-strap hoops on the lower front of the chassis. Hoops must be capable of accepting a 2-inch tow hook without lifting the body and not stressing the body when the car is being towed. Hoops must line up with the centerline of the car below the body-release rod and clearly marked on the body with an arrow pointing down.

TIRES & WHEELS: 5

WHEELS

Must be completely isolated from driver compartment. See General Regulations 5:2.

INTERIOR: 6**SHEET METAL**

Driver compartment interior, firewall, seat, etc. must be aluminum or steel. Magnesium or carbon fiber prohibited; carbon fiber injector “doghouse” permitted.

SEAT

Seats must be foamed with energy-absorbing material and formed to the driver’s body. Minimum one-layer, flame-retardant material mandatory as seat upholstery. No magnesium permitted.

BODY: 7**AIRFOILS, WINGS**

Prohibited.

BODY

Any modification to body not expressly permitted in this Rulebook is prohibited. Any body that meets the Funny Car (Section 17) body requirements in their entirety is acceptable for Top Alcohol Funny Car competition. These bodies must be run as they come from the NHRA-accepted molds. Any modification not expressly permitted in the Funny Car (Section 17) body requirements is prohibited. Otherwise, for cars running at NHRA national events, body must be 1992 or later model year. On cars not running NHRA national events, body must be 1972 or later model year. All bodies must be an NHRA-accepted sports car, coupe, or sedan body of a type originally mass-produced by automobile manufacturer (domestic or foreign). Must have originally measured 63 inches wide or more at centerline of front and rear axle. Maximum body and/or roof width cannot exceed stock dimensions. Duplications of production bodies of fiberglass or carbon fiber permitted. Body may be lengthened or shortened. Front and rear contour of body must resemble same configuration and design for specific body used; holes for air passage prohibited.

Maximum body width variation from front to rear is 6 inches. Minimum body width is 60 inches when mounted. Bodies are measured at centerline of front and rear axles. Enclosing the wheel-wells or the use of wheel fairings is prohibited. Fender flares or lips (maximum 1 inch) not on original factory-produced bodies will not be considered in any width measurement. Wheelwell openings: front, minimum 5 inches measured vertically from centerline of the front axle to wheelwell opening; rear, minimum 8 inches measured vertically from centerline of rear axle to wheelwell opening. Trailing edge of rocker minimum of 18 inches measured directly from centerline of rear axle. Front overhang not to exceed 40 inches from centerline of front axle. Beltline moldings (if on stock vehicle), headlight and taillight housings or indentations must be incorporated into body. Headlights and taillights must be painted or decaled to simulate OEM appearance and configuration. Taillight area may be hinged (top only) for air venting, maximum 100 square inches per side; any other holes in rear of body prohibited. Hood scoops prohibited; injector must protrude through hood. Maximum dimensions of hood cowl, 26 inches wide by 5 inches high. Opening for blower hat must have a minimum 2.500-inch clearance between body and throttle linkage. Wicker permitted on front and sides of blower opening; maximum height 1 inch. Wicker must be installed 90 degrees to body.

Rocker panel extensions may not be more than 1 inch wide. Ground effects of any description prohibited. Ground effects include, but are not limited to, rocker skirts, belly pans, sheet-

metal work under the body that produces a “tunnel” for the passage of air, rub bar/splitter cannot extend beyond the inside body line, etc. All bodies run in competition must be run as they come from the respective molds. Final determination on all body modifications rests with NHRA Technical Services Department.

Bodies must be removable from a rear-release mechanism that must be accessible in the taillight panel area. The rear-release mechanism may be of any mechanical design. The mechanism must be unobstructed and easily visible and not located within 3 inches of any other opening. Release handle must be of a T-handle design with a minimum measurement of 3 inches in length. Contact NHRA Technical Services Department for acceptable design, operation, and installation.

Body (hood) burst panel, minimum 288 square inches, mandatory on all screw-supercharger-equipped cars. Body burst panel must be secured with plastic screws and two NHRA-accepted body burst panel tethers, with separate body pads for each of the two tethers bolted with a plate on both sides of panel. NHRA-accepted body burst panel tethers: Amick Race Car Restraints part number JF-101. Any new body designs or concepts must receive approval from NHRA prior to competition. Plans, drawings, pictures, etc. must be submitted to the NHRA Technical Department for approval. Body specifications may vary for certain exhibition vehicles; prior NHRA approval necessary. Underside of body, including any roof area and all the composite components such as timer boxes, etc., must be covered with SFI Spec 54.1 flame-retardant covering or coating. Must be applied according to the manufacturer’s specifications and recommendations, and must be applied externally. All bolts and fasteners on body, windows, etc. must have button heads toward outside of body. All stiffeners must be placed on the inside of the body, whether on windows, spoiler, etc. Mounting trees for body may not be adjustable. The framing must be a permanent fixture, with no adjustments. Any method used to allow the body to move (e.g., springs, dampers, etc.) during the run is prohibited.

ESCAPE HATCH

A working escape hatch must be installed in top of body to permit easy driver exit, see-through types prohibited. Minimum size, 18 inches x 17 inches. Roof hatch must be permanently attached, and hinged at front. Must have release mechanism operable from both inside and outside of car.

FENDERS

Four stock-type fenders mandatory. Alterations to accommodate axle relocation permitted. Front fender bubbles may not exceed 2 1/2 inches as measured from flat portion of fender line to top of bubble.

FIREWALL

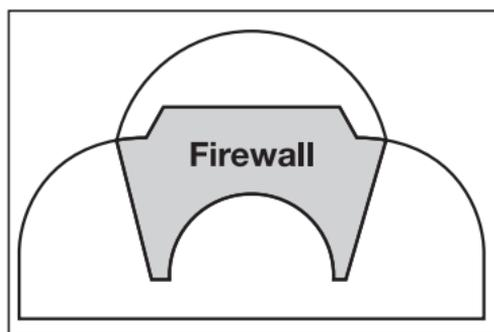

Must be aluminum or steel; magnesium prohibited. V-shaped firewall (see diagram) constructed of a minimum .040-inch aluminum permitted; otherwise, portion of the firewall between skin of the body and the chassis can be no higher than 12 inches,

as measured from the bottom of the rocker panel to the bottom

of the firewall. Must be equipped with “fire windows” measuring no greater than 25 square inches on either side of firewall in vicinity of valve covers to warn driver of fire. Laminated safety glass or fire-resistant plastics such as Lexan or Plex 70 mandatory. See General Regulations 7:4.

GRILLE

Must be equipped with a simulated grille of same configuration and design for specific body used; holes for air passage prohibited.

REAR BUMPER

Must be equipped with rear bumper consisting of a minimum vertical surface of 3 inches; maximum permitted cutout for parachute shroud lines, 4 inches by 30 inches. The trailing edge of rear bumper may not extend more than 54 inches from the centerline of the rear axle. Maximum measurement from trailing edge of rear bumper to ground, 29 inches at rear tire pressure of 4.5 PSI. Maximum 1-inch lip permitted on rear bumper as a stiffener; not included in overall measurement.

SPOILERS

Permitted front and rear. Rear spoiler cannot be “built in” to body. Rear deck relocation cannot extend more than one-third of the as-produced replica body’s rear window. Side surfaces of elevated decks must be completely covered by spoiler spill plates.

Maximum rear spoiler width, including spill plates and attachment points, 54 inches. Rear spoiler spill plates cannot be located forward of the centerline of the rear axle and onto rear quarter. Spill plates cannot be more than 5 inches above the roof line. Rearmost point of spill plate may not exceed 60 inches past the centerline of the rear axle. Spill-plate supports permitted on one side of spill plate only, not both. Lip on rear edge of spill plate (vertical) .5-inch maximum.

The trailing edge of rear spoiler may not extend more than 56 inches past the centerline of the rear axle, may not be more than 3 inches above the roof line, and the forward and trailing edge may not be mounted so as to preclude a “wing” configuration. Wicker on spoiler not to exceed 2 inches forward or back. Installation of vortex generators is permitted on the spoiler assembly only; prohibited on car body. Any adjustment or movement during run prohibited. Airflow through spoiler or past the underside of spoiler, other than hinged taillight area, prohibited.

WINDOW

Windshield mandatory. Side windows optional. If windows are used, they must be clear. Rear window and quarter windows (if stock equipped) must be defined by actual route line in body and painted (or decaled) to simulate glass. Side windows must have a minimum 6-inch-diameter opening adjacent to driver. See General Regulations 7:8.

SUPPORT GROUP: 9

FIRE EXTINGUISHER SYSTEM

Fire extinguishing system must meet SFI Spec 17.1. Minimum 20-pound NHRA-accepted fire extinguishing system mandatory. System must be divided so that a minimum of 15 pounds is directed into engine compartment by means of nozzled outlets placed in front of each bank of exhaust headers. Remaining 5 pounds or more should be dispersed in driver compartment by means of an atomizing nozzle placed at driver’s feet. Must be installed per manufacturer’s specifications. Fire bottle activation

cables must be installed inside framerail where cables pass engine/bellhousing area. See General Regulations 9:3 for NHRA-accepted fire extinguishing agents.

If equipped with a pneumatic-activated extinguishing system, a manual-activated extinguishing system is mandatory. If a manual-activated extinguishing system is primary, no backup system is required.

SHUTOFF DEVICE

Properly installed and operational Electrimotion Top Alcohol Funny Car Shutoff Controller Kit (part number SB001T AFC) and Electrimotion Shutoff Receiver (part number RF001) mandatory. The Electrimotion Top Alcohol Funny Car Safety Shutoff Controller Kit must be properly installed per the manufacturer's instructions. Modification of or tampering with the Electrimotion Top Alcohol Funny Car Safety Shutoff Controller Kit prohibited.

DRIVER: 10

DRIVER RESTRAINT SYSTEM

Mounting points must be covered with either sheet metal or an acceptable fire-resistant material. See General Regulations 10:5.

HEAD AND NECK RESTRAINT DEVICE/SYSTEM

At all times that the driver is in the race vehicle, from the ready line until the vehicle is on the return road, driver must properly utilize an SFI-approved head and neck restraint device/system, including connecting the helmet as required for full functionality of the device. The device/system must meet SFI Spec 38.1 and must display a valid SFI label. The head and neck restraint device/system, when connected, must conform to the manufacturer's mounting instructions, and it must be configured, maintained, and used in accordance with the manufacturer's instructions.

PROTECTIVE CLOTHING

Driver's suit meeting SFI Spec 3.2A/20, gloves 3.3/20, boots 3.3/20, and head sock 3.3 mandatory. All jacket and pants or driver suits that meet SFI Spec 3.2A/20 must be recertified on a five-year interval. A head sock is not mandatory when helmet is manufactured with a skirt, labeled as meeting SFI Spec 3.3. Fresh-air breathing system mandatory. System must be manufactured and installed by the original helmet manufacturer or with written authorization of the original helmet manufacturer. Helmet must meet applicable SFI and/or Snell Specs with fresh-air system installed. Compressed air only. Air can be supplied "on demand" or by constant pressure. See General Regulations 10:10.



SECTION 16 PRO STOCK MOTORCYCLE

DESIGNATION

PRO, preceded by motorcycle number.

Reserved for 1998 or later production stock-appearing, gas-burning, naturally aspirated motorcycles. Minimum weight at conclusion of run, including rider:

Harley-Davidson (must be NHRA-accepted)
(up to 160 cid; 60-degree angle, 2-valve, pushrod) - 625 pounds

Victory (must be NHRA-accepted)
(up to 160 cid; 60-degree angle, 2-valve, pushrod) - 625 pounds

American pushrod V-Twin (must be NHRA-accepted)
(up to 160 cid; 60-degree angle, 2-valve, pushrod) - 625 pounds

Kawasaki (must be NHRA-accepted)
(up to 107 cid, 2- or 4-valve) - 575 pounds

Suzuki (must be NHRA-accepted)
(up to 107 cid, 2-valve) - 590 pounds

Suzuki (must be NHRA-accepted)
(up to 113 cid, 2-valve) - 600 pounds

NHRA reserves the right to adjust weights as performance dictates.

Once an engine is used in a motorcycle at an event, that engine cannot be used in another motorcycle for the duration of the event. Engine shall consist of engine cases, crankshaft, block, and cylinder heads. Cases and heads will be serialized or otherwise identified at each event.

Serial number or identification mark on cases must be visible with body removed.

Any competitor who causes an oildown while participating at an NHRA Mello Yello event will be subject to fines and penalties as outlined in Section 2 - Oildown Penalties.

REQUIREMENTS & SPECIFICATIONS

ENGINE: 1

CYLINDER HEAD

Cylinder-head casting must be manufactured by the same manufacturer as the main engine cases. NHRA-accepted aftermarket cylinder heads permitted.

ENGINE

Contact NHRA for accepted cases. NHRA may designate specific acceptable OEM and/or aftermarket cases for specific makes of motorcycles. Only the Suzuki OEM production or NHRA-accepted engine case is permitted for use in Suzuki Pro Stock Motorcycles. Only the Kawasaki OEM production or NHRA-accepted engine case is accepted for use in Kawasaki Pro Stock Motorcycles. Only the Harley-Davidson NHRA-accepted engine is permitted for use in Harley-Davidson pushrod Pro Stock Motorcycles. Only the American pushrod V-Twin NHRA-accepted engine case is accepted for use in Buell-bodied and/or NHRA-specified body combinations. Maximum permitted cylinder offset for Harley-Davidson engine and the American pushrod V-Twin engine is 1 inch. Modifications to main engine cases are prohibited except for repair purposes. All engines must be self-starting; plug-in electric starters permitted. Push or roller starts prohibited. NHRA-accepted aftermarket engine cases permitted.

All moving engine components are restricted to aluminum, steel, iron, titanium, or other conventional alloys; carbon fiber, Kevlar, ceramics, composites, beryllium, or other exotic materials prohibited. See General Regulations 1:2.

FUEL

NHRA-specified Sunoco racing gasoline only. Dielectric Constant, as per NHRA DC meter, must match baseline reading of specified gasoline. The use of additives is prohibited. See General Regulations 1:6.

FUEL SYSTEM

Artificial cooling or heating systems (i.e., cool cans, ice, Freon, etc.) prohibited. Circulating systems not part of normal fuel-pump system prohibited. Electronics, pneumatics, hydraulics, or other devices may in no way affect the fuel system, including the venting system. Gas tank lid vent hose may not go forward past steering neck. Fuel sample must be taken directly from the fuel system. No additional fuel lines allowed for fuel-check purposes. All pressurized fuel systems must use lines that are metallic, steel braided, or NHRA-accepted woven or woven-pushlock. A current list of NHRA-accepted woven or woven-pushlock fuel lines is available on NHRARacer.com.

INDUCTION

Electronic fuel injection permitted. All electronic-fuel-injection systems must be NHRA-accepted. Only one fuel injector allowed per each cylinder. All inputs/outputs, sensors, transducers, and wiring related to the fuel-injection system and ignition system must be NHRA-accepted and used in an unaltered manner. Contact the NHRA Technical Department for an approved list of sensors, inputs/outputs, and wiring. A current list of NHRA-accepted electronic-fuel-injection systems

and additional system clarification is available on NHRARacer.com. See General Regulations 9:1.

OIL-RETENTION DEVICE

NHRA-accepted lower engine oil-retention device, or a belly pan constructed of an NHRA-accepted composite material or of minimum .032-inch aluminum, with no holes, and vertical walls at least 2 inches. Minimum number of slots or holes in the walls to clear frame or lines permitted. Front and rear walls must be "coved" toward oil pan a minimum of 1/2-inch to assist oil in staying within the confines of the oil-retention device. Pan must be attached at a minimum of three attachment points per side. A nonflammable, oil-absorbent liner located inside of retention device mandatory.

VACUUM SYSTEM

Maximum of two vacuum pumps permitted. Pump described as a device that removes air from engine. Should a drive motor have two pumps attached to it, this would be considered the maximum number of pumps permitted.

DRIVETRAIN: 2

CHAIN GUARD

Mandatory on all motorcycles. Chain guard must be steel or 1/8th-inch aluminum and must be securely mounted in three places. Chain guard must cover the width and at least the top run of the chain, from centerline to centerline of sprockets.

CLUTCH

Clutch must be manually operated by the rider's hand: Electronics, pneumatics, hydraulics, or any other device may in no way affect the clutch system.

TRANSMISSION

Any transmission with a maximum of six forward speeds, minimum four forward speeds, may be used. Transmission must be contained within the stock case, except Harley-Davidson or NHRA-accepted American pushrod V-Twin. Transmission must be shifted from gear to gear manually or by air shifter; electric shifters prohibited. RPM or computer-shifted gear boxes prohibited.

BRAKES & SUSPENSION: 3

BRAKES

Hydraulic type, front and rear, mandatory. Braided steel brake lines mandatory. Brake lines must be routed and mounted to ensure no contact with moving parts. Aluminum brake rotors prohibited. Automated brakes prohibited; application and release of brakes must be a function of the rider. Two rotor front brakes permitted; all rotor thickness tolerance +/- .010-inch from accepted 3/16-inch thickness. Minimum size: 10-inch diameter, 3/16-inch thickness for single rotor; 8-inch diameter, 3/16-inch thickness for dual rotor. Rear brake rotor minimum 10-inch diameter, 3/16-inch thick with single rotor front brake; 8 1/2-inch diameter, 3/16-inch thick with dual rotor front brake. Fork brace mandatory on all single rotor motorcycles. All brake systems must be NHRA-accepted aftermarket. Scalloping, notching, etc. of brake rotors prohibited; i.e., brake rotors must maintain a constant minimum outside diameter. See General Regulations 3:1.

CONTROLS

Handlebar controls must be located in the stock position. Welded aluminum handlebars prohibited. Welded steel or chromoly extensions permitted but cannot extend more than 4 inches from stock location. Minimum handlebar width 22 inches. SNAP BACK throttle return mandatory. Brake pedal and foot pegs may be rear set but must be at least 12 inches in front of rear axle. Note:

Engine exhaust must be directed away from rider's foot peg. Throttle and clutch levers must be manually operated by rider's hands. Electronic, pneumatic, hydraulic, or other devices may in no way affect the operation of throttle or clutch.

SUSPENSION

Front suspension minimum size: 35mm for OEM-type, 34mm for accepted aftermarket items. Minimum travel: 1 1/2 inches with rider sitting on motorcycle in normal riding position. Steering dampener mandatory. Electronics or pneumatics may in no way affect the front suspension. Any adjustment to front suspension during run prohibited. Rear suspension prohibited.

WHEELIE BARS

Maximum length, from centerline of front axle to centerline of wheelie-bar axle: 130 inches. On all mounting bars, butt welds or sleeved bar designs must have visible welded reinforcement (i.e., inner sleeve with rosettes, clam shells, bolted, etc.). Wheels must be nonmetallic.

FRAME: 4

BALLAST

Permitted. Ballast must be in weight box or securely bolted to frame by a minimum of one 3/8-inch bolt per five pounds.

FRAME

Aftermarket frames permitted. Steering head angle may not be less than stock rake or more than 40 degrees maximum rake. Frame must be inspected yearly by NHRA and have serialized sticker affixed to frame before participation. All frame components, except braces, brackets, and gussets, must be manufactured from minimum 1.00-inch x .058-inch 4130 chromoly tubing or be an NHRA-accepted design. All welding must be done by approved heliarc process. All frames must have stops that limit turning arc to 28 degrees. Stop must have a sheer strength equal to a 3/8-inch bolt. All butt welds must have visible reinforcement. Plating of frame prohibited. Painting permitted.

GROUND CLEARANCE

Minimum 2 inches with rider sitting on motorcycle with 6psi in rear tire.

WHEELBASE

Maximum 70 inches.

TIRES & WHEELS: 5

TIRES

Must be specified for racing use by manufacturer. Must be equipped with both tires bearing the same tire manufacturer's brand name. Maximum rear tire width: 10 inches. Minimum front tire width: 3 inches. (Tire sizes in actual widths.) See General Regulations 5:1.

WHEELS

Rear wheel minimum: 15-inch diameter; maximum: 18-inch diameter. Front wheel minimum: 16-inch diameter; maximum: 19-inch diameter. Carbon/composite wheels prohibited. A flat shield must be incorporated into the front wheel. The combination of the front tire, wheel, and a shield must measure a minimum of 5 1/2 inches from the ground. The front wheel may not have a polished surface and must be either dulled or flat black. The shield must be painted flat black; no other colors permitted. See General Regulations 5:2.

SEAT: 6

SEAT

Custom seats with a step to prevent the rider from sliding

backward permitted. Seat, tail section, and rear fender may be incorporated in one unit. Minimum seat height (with no rider in position and 6psi in rear tire) measured from lowest point of seating position to ground, 20 inches.

BODY: 7

AIR INTAKES

No external modifications allowed to NHRA-accepted scoops. Scoops external of the body or air-intake hoses prohibited, unless NHRA accepted. Sensors, transducers, vents, wiring, hoses, etc. prohibited inside air intake unless NHRA accepted. Use of existing air intakes on fairings is permitted. Front portion of gas tank shell may be cut for air intake opening, but location and execution must be approved by NHRA Technical Department.

BODY

Must have been originally produced with a 750cc or larger engine. All main body parts must have stock appearance and shape and cannot be mixed among models. Replacement parts permitted, but must retain the shape of the stock parts they replace. Brand name must appear on sides of body. Must have simulated headlight and taillight of same configuration and design as specific body used; holes for air passage prohibited. Aerodynamic devices prohibited unless originally incorporated into same OEM of that year. All motorcycles must successfully pass NHRA body inspection prior to competition. Contact NHRA for current list of available templates. NHRA approval required for all body styles regardless of manufacturer.

FAIRING

Upper portion of full fairing must be NHRA accepted. Lower portion of fairing may be modified for exhaust pipe clearance. Windscreen may be trimmed. No external extra scoops or air intake ducts may be added to the fairing. All factory openings must be present; no extra openings. Lip permitted on fairing only, maximum 1-inch wide by 10 inches long. If used, may not be molded into fairing.

ELECTRICAL: 8

IGNITION

All ignition systems and/or components must be NHRA-accepted. A current list of NHRA-accepted ignition systems is available on NHRARacer.com. Any other attachment prohibited. Ignition systems and/or components must be utilized in an unaltered manner consistent with the manufacturer's installation and instruction books unless otherwise approved. See General Regulations 8:3.

External belt-drive magneto ignitions prohibited. Must be equipped with a positive ignition cutoff switch attached to the rider with a lanyard. Switch must be on low-voltage side of ignition circuit.

SHIFT LIGHT

Shift light may be mounted in the helmet provided no modification to helmet is performed except by original manufacturer.

SUPPORT GROUP: 9

COMPUTER/DATA RECORDERS

Data recorders permitted; must be NHRA-accepted, standalone, and used for information gathering only. Accepted systems: Racepak V300 models, Dynatek, and Motec SDL3. Throttle operation, shifting, clutch actuation, etc. are to be solely under

the control of the rider. Data recorders may not collect any information from the induction system other than engine rpm. Digital dash displays acceptable but prohibited to be in view of the rider or externally from the bike. All other instrumentation prohibited on dash with the exception of a shift light and warning lights (i.e., low oil pressure, fuel pressure). See General Regulations 9:1, 9:2.

RIDER: 10

CREDENTIALS

Valid NHRA competition license mandatory. See General Regulations 10:4.

HELMET

Full-face Snell M2010, M2015, SA2010, or SA2015 helmet with shield mandatory (goggles prohibited). Eject Helmet Removal System (part number SDR 890-01-30) mandatory and must be installed per manufacturer instructions. A Stand 21 Lid Lifter head sock meeting SFI 3.3 may be used in lieu of the Eject Helmet Removal System. See General Regulations 10:7.

PROTECTIVE CLOTHING

Full all-leathers or non-leather suits meeting SFI Spec 40.1/2 mandatory, leather boots that completely cover the ankle, and leather gloves are mandatory. Gloves must be Kevlar-lined or equipped with slide buttons. Suits may be one-piece design or joined with a metal 360-degree zipper at the waist. See General Regulations 10:10.



SECTION 17 PRO STOCK

DESIGNATION

PRO, preceded by car number.

Reserved for 2009 or later NHRA-accepted 2-door or 4-door coupe or sedan (domestic or foreign) production vehicles. Any currently approved engine combination may be used in any currently approved body, regardless of the manufacturer. Body, drivetrain, chassis, etc. may not be altered, modified, or relocated, except as outlined in Requirements & Specifications. Minimum weight at conclusion of run: 2,350 pounds, including driver. Minimum weight on the rear axle at conclusion of run: 1,100 pounds, including driver.

Once an engine is used in a vehicle at an event, that engine cannot be used in another vehicle for the duration of the event. Engine shall consist short block and heads, and will be serialized or otherwise identified at each event.

Any competitor who causes an oiltdown while participating at an NHRA Mello Yello event will be subject to fines and penalties as outlined in Section 2 - Oildown Penalties.

REQUIREMENTS & SPECIFICATIONS

ENGINE: 1

AIR INDUCTION

See NHRARacer.com: NHRA Accepted Products, NHRA Accepted Product Specifications, Pro Stock, Pro Stock Air Induction Requirements for requirements.

CYLINDER HEADS

Hemi, canted-valve or wedge cast heads permitted. Billet heads prohibited. Aftermarket heads permitted if designed and cast with OEM approval, and currently accepted by NHRA. Accepted cylinder heads: (Hemi cylinder head, part/casting number P4876833, P5155936 or part/casting number P5153447), (DRCE cylinder head, part/casting number 22530959, DRCE II cylinder head, part/casting number 24502585, DRCE III cylinder head, part/casting number 25534404 or the DRCE IV cylinder head, part/casting number 25534404) (Ford cylinder head, part/casting number M-6049-E460, or part/casting number M-6010-JC50, or part/casting number M-6010-JC51). All heads designed and cast after 2/1/1991 must include OEM part/casting number plus OEM logo identification, and must be NHRA-accepted. Any valve configuration or valve size permitted. Stock valve cover mounting surface and head height (thickness) at highest valve cover surface mandatory. Ports may be raised. Port plates permitted, may be higher than head, no wider than 1 1/2 inches, may not be recessed into head more than plate width. Plates permitted on intake or exhaust side, not both. Maximum two valves per cylinder; maximum one spark plug per cylinder.

ELECTRONIC FUEL INJECTION SYSTEM

See NHRARacer.com: NHRA Accepted Products, NHRA Accepted Product Specifications, Pro Stock, Pro Stock Electronic Fuel Injection Requirements for requirements.

ENGINE

Internal-combustion, reciprocating, naturally aspirated, single camshaft, 90-degree V-8 (i.e., cylinder bank must be at a 45-degree angle from the camshaft/crankshaft centerline, creating a combined 90-degree angle) automotive-type engine. For a more detailed description, contact the NHRA Technical Services department. Maximum 500 cid. Aftermarket blocks permitted if designed and cast with OEM approval, and currently accepted by NHRA. NHRA may designate specific acceptable OEM and/or aftermarket blocks for specific makes of cars. Accepted blocks: (Hemi block, part/casting number P4876887 or part/casting number P5153454) (DRCE block, part/casting number 24502572, or the DRCE III block, part/casting number 25534402) (Ford block, part/casting number M-6010-A500, or part/casting number M-601-JC50, or part/casting number M-601-JC51. Maximum cylinder bore spacing 4.900 inches. Maximum one distributor. See General Regulations 1:2.

All dry sump oil systems must be equipped with an overflow tank. The minimum size of tank is 8 inches long, 3 1/2 inches in diameter with a 1-inch vent in the top. Inlet minimum size is #10 fitting. Tank must also have a baffle installed so as to direct incoming oil to bottom of tank. Minimum size for drain in bottom of tank is 1/4-inch.

All large components (valve covers, intake manifolds, headers,

heads, blocks, etc.) and all moving engine components are restricted to aluminum, steel, iron, titanium, magnesium, or other conventional alloys; carbon fiber, Kevlar, ceramics, composites, beryllium, or other exotic materials prohibited.

Minimum weight requirements for the following engine components: Piston - 460 grams; Wrist pin - 135 grams; Connecting rod - 480 grams; Intake valve - 90 grams; Exhaust valve - 80 grams.

Material for intake and exhaust pushrod and valve spring is limited to steel. All other materials prohibited. Roller bearings limited to cam bearings, cam thrust bearings, lifters, and rocker arm fulcrum and valve spring tip. Conventional sleeve rod and main bearing mandatory.

Semi-permanent manifold covers permitted. Manifold covers must remain firmly attached to the manifold during the run, but must be easily removable for technical inspection. All new manifold covers must be reviewed and accepted by the NHRA Technical Department.

ENGINE SETBACK

Maximum 81.5 inches; minimum setback 84.5 inches. Measured from centerline of rear axle to rear of engine block. Machining of the block to allow further setback prohibited.

EXHAUST SYSTEM

Open exhaust with headers permitted. See General Regulations 1:3.

FUEL

NHRA-specified Sunoco racing gasoline only. Dielectric Constant, as per NHRA DC meter, must match reading from baseline of specified gasoline. The use of additives is prohibited. See General Regulations 1:6.

FUEL SYSTEM

All fuel cells must be NHRA-accepted (Jaz #220-015-0, 220-115-01, and 220-315-01); maximum 1 1/2-gallon fuel cell meeting SFI Spec 28.1 mounted in front of radiator mandatory; must be mounted between framerails and enclosed in a round tube frame, minimum 1 1/4-inch O.D. x .065-inch chromoly tubing. The round tube frame must be attached to a cross member constructed of minimum 1 1/4-inch O.D. x .065-inch chromoly tubing. All other designs must be NHRA accepted. Maximum distance from front motor plate to front of 1 1/4-inch tube is 38.5 inches. Must have pressure cap and be vented. Extra tank(s) prohibited. Artificial cooling or heating systems (i.e., cool cans, ice, Freon, etc.) prohibited. Circulating systems not part of normal fuel-pump system prohibited. See NHRARacer.com: NHRA Accepted Products, NHRA Accepted Product Specifications, Pro Stock, Pro Stock Electronic Fuel Injection Requirements for additional requirements. See General Regulations 1:5.

OIL-RETENTION DEVICE

All vehicles must utilize an NHRA-accepted lower engine oil-retention device; may use a belly pan in lieu of device attached to the engine. Pan must be constructed of an NHRA-accepted composite material with vertical folded-up walls, at least 4 -inches tall. Pan must run from in front of the front motor plate to in front of the rear motor plate and to just inside or outside of the lower framerails. Minimum number of slots or holes in the walls to clear frame, steering, or lines permitted. Front and rear walls must be "coved" toward oil pan a minimum of 1/2-inch to assist oil in staying within the confines of the oil-

retention device. Pan must be attached with a minimum of three attachment points per side. A non-flammable, oil-absorbent liner mandatory inside of retention device.

RADIATOR

Only one automotive radiator in front location, with only one water pump mandatory in engine compartment. Remote mount permitted. External plumbing from water pump to block and/or cylinder head(s) permitted. Water pump and fan may be electrically driven.

THROTTLE

Throttle control must be manually operated by driver's foot: Electronics, pneumatics, hydraulics, or any other device may in no way affect the throttle operation. See General Regulations 1:12.

DRIVETRAIN: 2

CLUTCH, FLYWHEEL, FLYWHEEL SHIELD

Flywheel and clutch meeting SFI Spec 1.1, 1.2, 1.3, or 1.4 mandatory. Flywheel shield meeting SFI Spec 6.2 or 6.3 mandatory on any car using SFI Spec 1.3 or 1.4 clutches. Maximum 3 discs. Minimum disc diameter 6 inches. Clutch release must be manually operated by driver's foot: Electronics, pneumatics, hydraulics, or any other device may in no way affect the clutch system. Multi-stage, variable release, lockup-type clutch of any description prohibited. Throwout bearing must release all fingers, levers, stages, etc. simultaneously.

Flywheel shield cannot be welded into the car and/or frame (used as a crossmember). Frame and/or body braces cannot be welded to flywheel shield. See General Regulations 2:3, 2:5, 2:6, 2:9.

DRIVELINE

Driveshaft must meet SFI Spec 43.1. Front-wheel-drive cars must be converted to rear-wheel drive. Each end of driveshaft must have round 360-degree driveshaft loops within 6 inches of U-joints. Additionally, driveshaft must be covered by 360-degree tube, covering the front U-joint and extending rearward a minimum 12 inches. Minimum thickness of tube is .050-inch chromoly or titanium. Driveshaft tube must utilize a minimum of four attachment points to the chassis, either bolted with minimum 5/16 SAE bolts or welded or 1/4-inch push/pull pins. See General Regulations 2:4.

REAR END

Aftermarket axles mandatory. Full-floating or live axle units permitted. Minimum 40 spline axles mandatory. See General Regulations 2:11.

TRANSMISSION

Aftermarket planetary or clutchless transmission with a maximum of five forward speeds and reverse permitted. Automatic transmission prohibited. Automated, timer-type, pneumatic, electric, electronic, hydraulic, etc. shifting mechanism prohibited; each individual shift must be a function of the driver and controlled manually.

BRAKES & SUSPENSION: 3

BRAKES

Automated brakes prohibited; application and release of brakes must be a function of the driver. Four-wheel hydraulic disc brakes mandatory. Carbon-fiber brake rotors used in conjunction with carbon-fiber specific brake pads (front and

rear) mandatory; all other materials prohibited. Brake lines must be out of flywheel and driveline area. Line-loc permitted on front wheels only, must be driver activated. Any other electrical, pneumatic, hydraulic, etc. switch prohibited in brake system. See General Regulations 3:1.

STEERING

Stock-type steering in conventional location mandatory. Commercially available quick-disconnect steering wheel meeting SFI Spec 42.1 mandatory. Minimum steering-wheel diameter 11 inches O.D. Maximum 2 buttons allowed on steering wheel. See General Regulations 3:3.

SUSPENSION

Full automobile production systems mandatory. On NHRA-accepted 4-link suspension systems, when quick-pins are used, pins must have an attachment to keep them from falling onto racing surface when not in use. Minimum 1 hydraulic shock absorber per wheel. Fabricated units permitted. Rigid-mounted suspensions or straight front axles prohibited.

Active suspension of any kind prohibited. Any ability to make on-track setting/rate changes based on "real time" data or input from any source, including the shock/strut itself (i.e., magnetically charged fluid), is prohibited.

Electrically controlled, hydraulic shocks and/or struts are permitted, provided all adjustment settings/changes are preset before the run. All shocks systems must be NHRA-accepted. Only 1 three-wire shielded cable connection is permitted from the top of the shock/strut to the shock/strut controller. Electrical connections of any other kind to or from the shock/strut prohibited. Shock/strut travel sensors permitted, but may ONLY be connected to the vehicle data recorder. Shock/strut control boxes that have connections for travel sensors must have the pin removed from the connector. Connection to serial port on control box prohibited once car reaches the ready line. All wiring must be visible and easily traceable for technical inspector. Control boxes must be NHRA-accepted. A current list of NHRA-accepted control boxes is available on NHRARacer.com. Shock/strut may have a maximum of three air lines connected to an air bottle. See General Regulations 3:4.

WHEELIE BARS

Permitted. Wheels must be nonmetallic. Maximum length 66 inches, measured from the center of the rear axle to the center of the bolt in the wheelie-bar wheel. See General Regulations 3:6.

FRAME: 4

BALLAST

Permitted. Any ballast mounted on, or in front of, forward crossmember is limited to 30 pounds maximum, including bracket. Maximum length of bracket 12 inches, measured from the front of the crossmember. Width of bracket may not exceed width of lower frameroils. Maximum amount of ballast allowed to be attached to the single-tube-frame-design fuel-cell tube is 25 pounds. If support bars constructed of minimum 1/2-inch x .049-inch tubing are installed to support the single-tube-frame design, maximum of 40 pounds of ballast may be attached. Support bars may either be welded or bolted. Must be NHRA-accepted design. Maximum distance from front motor plate to front of bracket is 36 inches. Bracket may be constructed of either minimum 1 1/4-inch x .058-inch wall round chromoly tubing with minimum four (4) 3/8-inch-diameter SAE Grade 8 bolts for attachment, or of minimum 1/4-inch 6061 T6 aluminum plate with minimum

four (4) 1/2-inch SAE Grade 8 bolts for attachment, or NHRA-accepted design. All other weight bars, pucks, etc. must use minimum 1/2-inch-diameter SAE Grade 8 bolts for attachment. Ballast may not be mounted higher than the top of the wheel tubs with the exception of the Funny Car cage area. In the Funny Car cage area, ballast may not be mounted higher than the top of the driver's shoulders. Disguised ballast prohibited (this includes solid tubing, etc. welded to chassis above the top of the rear wheel tubs). See General Regulations 4:2.

GROUND CLEARANCE

Minimum 3 inches from front of car to 12 inches behind centerline of front axle, 2 inches for remainder of car, except oil pan and exhaust headers.

PARACHUTE

Dual parachutes mandatory. Parachutes must be mounted such that the maximum measurement between the outside edge of the two parachutes does not exceed 24 inches. Parachute packs may not be enclosed. Parachutes must be assisted by a launcher system – either air or spring. A pilot spring does not constitute a launcher but is acceptable as a secondary launch unit. No more than 3.5 inches of any portion of the parachute pack can be located under the rear of the spoiler. Measured from the parachute pack backing plate to the rear tip of the spoiler. Pneumatic parachute must use minimum 3/8-inch O.D. line; cannot use separate air supply from other pneumatic functions. A bushing is mandatory over the shroud-line mounting bolt(s). Lower parachute mounting supports must be bolted; upper mounts may be pinned. See General Regulations 4:8.

ROLL CAGE

Chassis must meet SFI Spec 25.1. Chassis must be recertified yearly by NHRA and have serialized sticker affixed to roll cage before participation. See General Regulations 4:4, 4:11, 10:6.

A panel of .032-inch aluminum, .024-inch steel, or carbon fiber must be installed on the inside portion of the roll cage anywhere the driver's legs can come into contact with the cage. Panels must be installed in the front and lower portion of the driver's-side X brace. Panels must attach to the interior side of the tubing, or no farther than the middle of the tubing, with "impact-type" padding attached to the panels. Padding must extend to be flush with X brace. See General Regulations 4:4, 4:11, 10:6.

ROLL-CAGE PADDING

Roll-cage padding meeting SFI Spec 45.1 mandatory anywhere driver's helmet may come in contact with roll-cage components. Additional padding mounted on flat stock and fastened to the roll cage on both sides of the driver's helmet, mandatory. Additional padding must be NHRA-accepted (with manufacturer's name displayed), securely mounted using bolts or locking fasteners, and must include a flame-retardant covering. A current list of NHRA-accepted lateral head supports is available on NHRARacer.com. See General Regulations 4:11.

WHEELBASE

Maximum 105 inches, minimum 104 inches; maximum wheelbase variation from left to right: 1 inch.

TIRES & WHEELS: 5

TIRES

Restricted to Goodyear-only tires, as specified by NHRA. Clearance from outside of front tire to inside of fender at closest point not to exceed 4 inches. Rear clearance 5.5 inches from outside of tire to inside of fender at widest point. Maximum

height of front tire is 25 inches. See General Regulations 5:1.

WHEELS

All Pro Stock rear wheels must meet a minimum SFI Spec 15.1, measuring 16x16 inches; beadlock design, with an inner bead minimum 14 3/4 inches (+/- 1/8-inch). Any SFI Spec wheel must be used in an unaltered manner consistent with the manufacturer's installation and instruction books unless otherwise approved in writing by NHRA. Modification and/or lightening prohibited. Wheel discs or covers prohibited. See General Regulations 5:2.

INTERIOR: 6

SHEET METAL

Driver compartment interior must be aluminum, steel, or NHRA-accepted carbon fiber. Magnesium prohibited. Sheet metal may not extend into rear window any higher than wheel tubs. Trunk must be completely separated from driver compartment with firewall.

UPHOLSTERY

Driver's seat must be minimum 24 inches high. Seat must be foamed with energy-absorbing material and formed to the driver's body. Minimum one-layer, flame-retardant material mandatory as seat upholstery. Removal of passenger seat permitted. Seat frame must be installed as a permanent part of the chassis. Dashboard exterior appearance must be retained. Fiberglass replica of original permitted. Gauges may be painted in or simulated. Headliner area must have a finished appearance.

WINDOW NET

Window net meeting SFI Spec 27.1 mandatory. Window nets must be either ribbon or mesh type. No solid material type. See General Regulations 6:3.

BODY: 7

BODY

Sports cars, sedan deliveries, trucks prohibited. NHRA-accepted composite body mandatory. Chopping, channeling, sectioning, or other alterations to contour, length, or width prohibited. Modification to NHRA-accepted body components prohibited, except for minor trimming to fit. Maximum front end overhang is 45 inches. All measurements must remain within the tolerances found on the NHRA Pro Stock Body Measurement Legend sheets. All cars must successfully pass NHRA body template inspection prior to competition. Contact NHRA Technical Services Department headquarters for body dimensions and available templates. NHRA approval required for all body styles regardless of manufacturer. All body mounts must be non-adjustable.

Ground effects of any description prohibited. Ground effects include but are not limited to rocker skirts, belly pans, sheet-metal work to the under side of the car that produces a "tunnel" for the passage of air, etc. Front splitter mandatory, must attach to the lower front fascia. Splitter must be constructed of aluminum, steel, or stainless steel with a minimum thickness of .050-inch and a maximum .060-inch. Any additional lips or flanges prohibited. Splitter must be flat and parallel to the front lip. Mounting of the splitter must be NHRA-accepted. The 3/8-inch lip in the front will not be included in the front overhang measurement. Maximum 2.5-inch inner lip allowed around front portion of front end. Front portion to be considered area from front-wheel opening extending around front end to front of opposite front-wheel

opening. Maximum width of rocker-panel support, 3 inches. For body modifications, final determination rests with NHRA Technical Services Department, as determined by the NHRA Technical Services Department in its sole and absolute discretion.

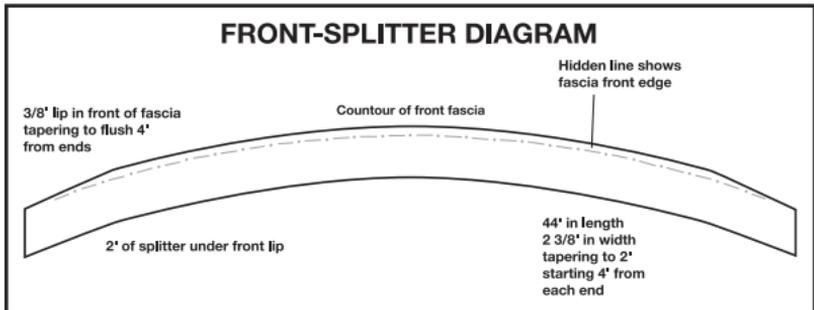

DOORS

Must be functional and operable from inside and outside. Doors must be NHRA-accepted. Must have sheet-metal deflector plate between fenders and leading edge of doors.

FIREWALL

Moving stock firewall location rearward for engine installation permitted. Minimum .024-inch steel firewall mandatory on any car constructed after Oct. 31, 2006. See General Regulations 7:4.

FLOOR

Driver's-side floor pan must be steel and must be welded in place. Driver's- and passenger's-side floor pan must be steel and welded in place on any car built after Oct. 31, 2006. Remainder of stock floors may be replaced with .024-inch steel or .032-inch aluminum or NHRA-accepted carbon fiber permitted. Subfloors and/or belly pans prohibited with the following exception: Floor area between the center frameraills extending from the rear crossmember to the bellhousing may be enclosed from the bottom side. Must use minimum .024-inch steel, .032-inch aluminum, or carbon fiber for material. Magnesium prohibited. Maximum width for enclosure is 24 inches. Material may not extend more than halfway around on outside of center frameraills and may be two pieces. May be either welded in or removable. Floor supports acceptable; maximum total width of material for supports 4 inches. Chassis, frame, and driveline must be below floor. Rear floor may not be higher than 8 inches above door sill. Driveline tunnel behind driver's seat may be higher for proper clearance. Magnesium interior panels prohibited. See General Regulations 7:5.

GRILLE

Must be equipped with a simulated grille of same configuration and design for specific body used; holes for air passage prohibited.

SPOILERS

Rear spoiler mandatory; length 14 inches mandatory; may only use NHRA-accepted spoiler designed for each specific NHRA-accepted body style. Spoiler will be measured from the body line/spoiler transition point to rear of spoiler. A 90-degree wicker is mandatory across the full width of the spoiler. Minimum wicker height is 3/4-inch. This measurement will be taken on the inside of the wicker. Wicker must be constructed of carbon fiber, aluminum, steel, or stainless steel with a minimum thickness of .050-inch. Wicker must be nonadjustable and permanently attached to the rear of the spoiler so it remains 90 degrees to the spoiler at all times during the run. Height of the wicker is

not included in the total length of the spoiler measurement. Rear spoiler may not be molded into deck lid. All spoilers must be painted to match paint scheme. Minimum angle of the rear spoiler may not be lower than horizontal. Roof-mounted spoilers prohibited. Air foils prohibited. Any adjustment or movement during run prohibited.

Spoiler measured as follows:

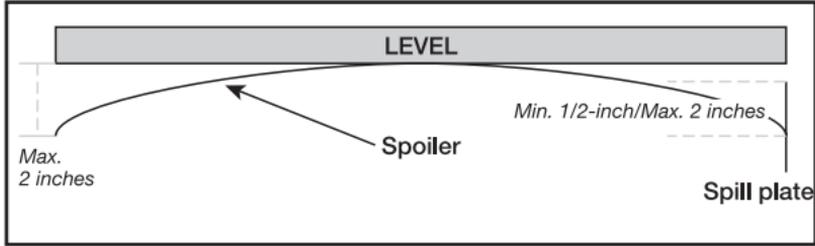

A straight edge will be placed on the spoiler, perpendicular to the centerline of the car and level to the ground. Distance between level and lowest part of spoiler not to exceed 2 inches. Mandatory height of spill plate 6 inches (+/- 1/8-inch variance); must be attached to spoiler so that a mandatory 1 inch (+/- 1/8-inch variance) extends above edge of spoiler; must be vertical to the spoiler. Spill plate may not extend more than 2 inches past rear of spoiler, measured from where it attaches to the spoiler. Spoiler and fill area combined may not be more than 23.5 inches in total length; spillplate may not extend forward of the spoiler fill area or more than 2 inches past rear of spoiler or be more than 26 inches long.

When the quarterpanel and deck lid follow different contours, a maximum 6.5-inch-long filler area is permitted on front edge of the spoiler to permit spoiler to follow contour of deck lid. Filler area must follow quarterpanel contour and may not be fashioned so as to permit air to pass underneath it.

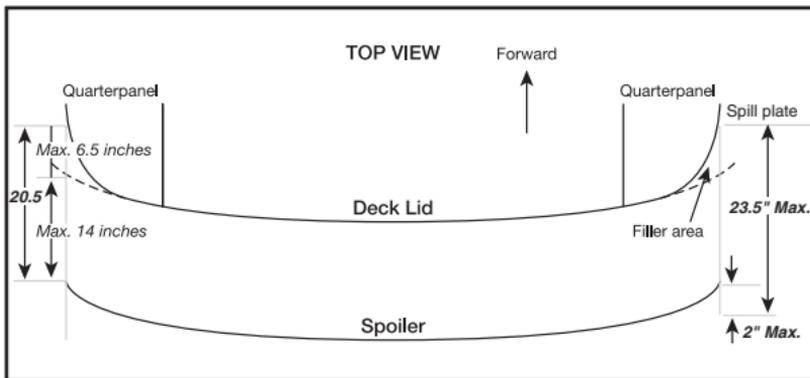

STREET EQUIPMENT

Complete taillight assembly must be retained in stock original factory location. Headlight design must be approved by NHRA. One functional taillight mandatory. Headlights, parking and stop lights, and taillight cannot be painted on body. Side marker lights optional. Any other street equipment that does not affect external appearance may be removed.

WHEELWELLS

Rear wheelwells must be separate for each tire. Maximum height of rear wheel tubs from ground, 40 inches.

WINDSHIELD, WINDOWS

Full windows mandatory, side and rear windows, 1/8-inch-minimum-thickness polycarbonate material permitted.

Windshield, 3/16-inch-minimum-thickness polycarbonate material required. Must match original contour and mount in stock location. Windows must be closed. Cutting and/or notching windshield permitted if covered by hood and/or scoop. Windshields and/or windows must be clear, without tinting or coloring. The vehicle's manufacturer or model name must be displayed with a decal on the windshield just below the roof line. The identification decal must be no smaller than 2.125 inches and no larger than 4.5 inches in height. Side windows, including quarter windows, limited to driver's name, car number, car builder name, class designation, and decals only. Paint scheme may not extend into these windows. Decals may not completely cover these windows. Outer edge of windows must remain uncovered. NHRA reserves the right to accept or prohibit placement of decals on windows as deemed necessary to comply with this rule. See General Regulations 7:8.

ELECTRICAL: 8

BATTERY

Maximum two batteries; total weight wet, fully charged, including battery box: 100 pounds. Trunk installation mandatory. See General Regulations 8:1.

IGNITION

See NHRARacer.com: NHRA Accepted Products, NHRA Accepted Product Specifications, Pro Stock, Pro Stock Electronic Fuel Injection Requirements.

MASTER CUTOFF

Mandatory. See General Regulations 8:4.

SUPPORT GROUP: 9

COMPUTER/DATA RECORDERS

Data recorders permitted; must be standalone, NHRA-accepted, and used for information gathering only. See NHRARacer.com: NHRA Accepted Products, NHRA Accepted Products, Data Recorders. Digital dash display acceptable. Ride-height sensors permitted; may only be connected to data recorder. See General Regulations 9:1, 9:2.

EVENT DATA RECORDER

Properly installed and operational PRC Systems Event Data Recorder (part number EDR1.0 or EDR2.0) and PRC Systems Wire Assembly (part number WA1.0 or WA2.0) mandatory. The PRC Systems Event Data Recorder and Wire Assembly must be installed per the manufacturer's instructions. Modification of or tampering with the PRC Event Data Recorder and Wire Assembly prohibited.

FIRE EXTINGUISHER SYSTEM

Fire extinguishing system must meet SFI Spec 17.1. Minimum 5-pound NHRA-accepted fire extinguishing system mandatory. System must be divided with one nozzle on driver's side and one nozzle on engine. If fire bottle is mounted in front of the firewall, it must be connected to the nozzle system with a flexible steel braided line. All cars are required to have a pneumatic cylinder, pressurized by the fire system, that will activate the master kill switch and shut off the engine when fire system is activated. Minimum size - 5/8 inches. See General Regulations 9:3 for NHRA-accepted fire extinguishing agents.

PRESSURIZED BOTTLES

Maximum one pressurized container per vehicle. See General Regulations 9:8.

SHUTOFF DEVICE

Properly installed and operational Electrimotion Pro Stock Shutoff Controller Kit (RF001PS) mandatory. The Electrimotion Pro Stock Shutoff Controller Kit must be properly installed per the manufacturer's instructions. Modification or tampering with the Electrimotion Pro Stock Shutoff Controller Kit prohibited.

TOW VEHICLES

Golf cart or three- or four-wheeled, Quadrunner/ATV-type tow vehicle permitted. Full-size tow vehicle prohibited. See General Regulations 9:12.

WARM-UPS

See General Regulations 9:5, 9:14.

DRIVER: 10

CREDENTIALS

Valid NHRA competition license mandatory. See General Regulations 10:4.

DRIVER

Must be in stock location. Driver's seat to be no less than 22 inches from center of rear axle to seat back (where shoulder harness passes through).

DRIVER RESTRAINT SYSTEM

Driver restraint system meeting SFI Spec 16.1 or 16.5 mandatory. Restraint system must be updated at two-year intervals from date of manufacture. See General Regulations 10:5.

HEAD AND NECK RESTRAINT DEVICE/SYSTEM

At all times that the driver is in the race vehicle, from the ready line until the vehicle is on the return road, driver must properly utilize an SFI-approved head and neck restraint device/system, including connecting the helmet as required for full functionality of the device. The device/system must meet SFI Spec 38.1 and must display a valid SFI label. The head and neck restraint device/system, when connected, must conform to the manufacturer's mounting instructions, and it must be configured, maintained, and used in accordance with the manufacturer's instructions. See General Regulations 10:8.

HELMET

Full-face helmet meeting Snell M2010, M2015, SA2010, or SA2015 mandatory; shield mandatory (goggles prohibited). Eject Helmet Removal System (part number SDR 890-01-30) mandatory and must be installed per manufacturer instructions. A Stand 21 Lid Lifter head sock meeting SFI 3.3 may be used in lieu of the Eject Helmet Removal System. See General Regulations 10:7.

PROTECTIVE CLOTHING

Jacket and pants or suit meeting SFI Spec 3.2A/15, gloves meeting SFI Spec 3.3/5, and shoes meeting SFI Spec 3.3/5 mandatory. An SFI 3.3 head sock or SFI 3.3 skirted helmet is required on all cars, where a neck collar is not used. See General Regulations 10:10.



SECTION 18 FUNNY CAR

DESIGNATION

FC, preceded by car number.

Reserved for supercharged, fuel-burning Funny Cars built specifically for drag racing competition. Minimum weight at conclusion of run: 2,585 pounds, including driver.

Any competitor who causes an oildown while participating at an NHRA Mello Yello event will be subject to fines and penalties as outlined in Section 2 - Oildown Penalties.

Any proposed changes to vehicle design or vehicle components must be submitted in writing to the NHRA Technical Department for review and approval or disapproval, in NHRA's sole and absolute discretion. Only safety-enhancing modifications will be considered for approval and implementation during 2019. Performance-enhancing modifications may be submitted for approval; however, even if approved for future use, it is NHRA's plan that no performance-enhancing modifications will be implemented during 2019.

Plans for proposed changes to vehicle design or vehicle components and, if practicable, prototypes, must be submitted to the NHRA Technical Department as part of the review process. Fees and costs, if any, incurred by NHRA in determining whether to approve or disapprove the proposed changes to vehicle design or vehicle components shall be borne by the party submitting the items for review. Approval, if granted, is valid only if such approval is granted in writing, signed by the Director of Engineering, Technical Operations. No proposed changes to vehicle design or vehicle components can be used in competition unless such written approval has first been granted.

Proposed changes to vehicle design or vehicle components includes, but is not limited to, engine blocks, cylinder heads, intake manifolds, fuel pumps, superchargers, body components, wing components and electronics, and includes any redesign, reconfiguration, and/or modifications to existing components. It is the participant's responsibility to refer any development, redesign, reconfiguration, and/or modification questions with respect to Funny Car components to the NHRA Technical Department to determine whether permitted or prohibited before using in competition, and disqualification or other penalties determined in NHRA's discretion may result if this procedure is not followed.

Non-approved parts/components are not permitted on race vehicles at **any time** (including any/all qualifying day(s) and eliminations) during a National Event. If a vehicle is found to be using any item or component that is different from that which is approved, including an item or component that has been modified or altered from the approved configuration, then the driver will be penalized with a deduction of 75 points and the team and/or driver (in NHRA's discretion) will be penalized with a minimum \$25,000 fine. If not paid, the fine may be withheld from any purse/prize monies; if NHRA is unable to collect the fine from purse/prize monies the team may not be allowed to compete again, in NHRA's discretion. Multiple violations and/or flagrant disregard for this policy may result in additional penalties as determined by NHRA in its sole and absolute discretion. Such additional penalties may include disqualification, suspension or loss of season points. Among items and components that are subject to inspection and penalty if found to be different, altered, modified or otherwise not the same as the item or component that is approved, are the following: injector hats; supercharger cases (excluding end plates); supercharger inserts; supercharger rotors; intake manifolds; cylinder heads (intake valve sizes may be increased to 2.470 inches max.); engine blocks; magnetos; ignition systems; data acquisition systems; safety shutoff system; pan pressure shutoff system; event data recorder; front wings; rear wings; tires; and nitromethane.

REQUIREMENTS & SPECIFICATIONS

ENGINE: 1

ENGINE

Any internal-combustion, NHRA-accepted, reciprocating, 90-degree V-8, single-camshaft, automotive-type engine permitted. Multi and/or overhead cam configuration prohibited. Maximum 500 cid; maximum bore center spacing 4.800 inches; maximum cam centerline 5.400 inches, maximum two valves per cylinder. Only one cylinder-head design is acceptable:

Intake valve angle of 35 degrees, + or - 1 degree

Intake valve size maximum: 2.470 inches

Exhaust valve angle of 21 degrees, + or - 1 degree

Combined intake and exhaust valve size maximum: 4.395 inches

Bore size: 4.1875 inches, +.004-inch

Engine block must be forged aluminum and NHRA-accepted. Cast aluminum blocks prohibited.

Dry-sump oil system mandatory. Dry-sump system tank must be mounted inside framerails. Engine must be equipped with an NHRA-accepted SFI Spec 7.1 lower engine ballistic/restraint flexible type device. A positive method (flange, lip, etc.) must be attached to the intake manifold or engine block to retain both the front and rear manifold to block gasket(s). The flange/lip must extend past the surface of the gasket and be contoured to closely fit the block and manifold surfaces to prevent the gasket from extruding. An inner diaper, Taylor part number 001-ID-FC, NitroSew part number 4028, or DJ Safety part number 750500. Carbon fiber/composite oil pan prohibited.

EXHAUST

Double-pipe insulated exhaust headers mandatory. Minimum Funny Car header angle 40 degrees, measured in reference to ground and parallel to the center line of the car (X axis). Maximum width of headers: 83 inches. Maximum header height 11.5 inches, measured from the ground to the highest point at the exit of the exhaust.

Maximum header pipe O.D. 2.75 inches. O.D. and I.D. must remain constant beginning 8 inches below the header flange to the exit of the header. Centerlines of all four exhaust pipes must be parallel to each other and each pipe must contact adjacent tube.

FUEL INJECTOR HAT

Maximum permitted fuel injector air inlet opening: 65 square inches, excluding cross shaft in fully open position. The maximum accepted height from the crankshaft centerline to the top of the injector hat is 34.000 inches. The injector hat shall extend forward no more than 10.375 inches from the front of the injector hat to the front bolt on the blower case opening. Electronic or electrically controlled fuel injection prohibited. Any NHRA-approved modification must be performed by the original manufacturer only.

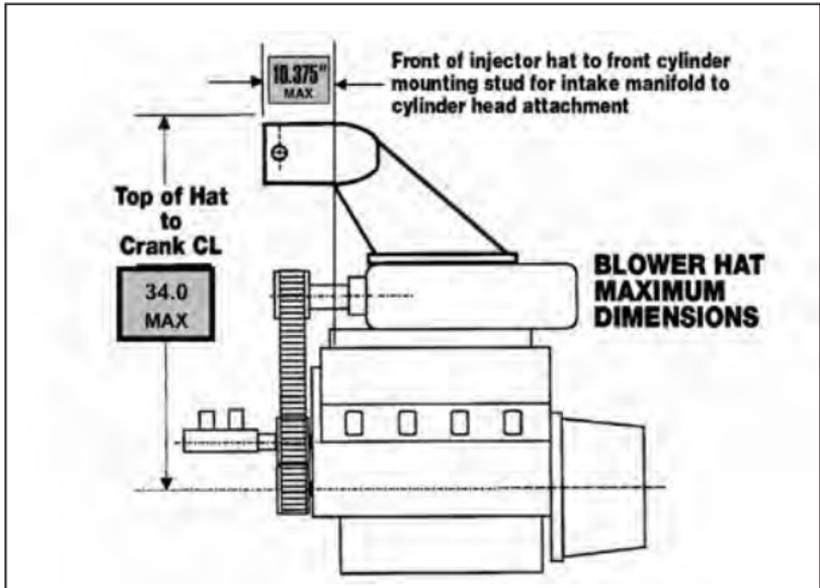

FUEL SYSTEM

Fuel gauge lines in the driver compartment must be steel-braided with steel fittings. Fuel cells permitted. Pressurized fuel tanks prohibited. Mandatory fuel tank vent, 1-inch-diameter (+0.25-inch) hole in front of body to vent fuel tank outside of body. All flexible fuel-pressure lines, with the exception of the hat nozzle lines, must be pressure tested and labeled. All testing must be hydrostatic for minimum 30 seconds at 750psi. Label must indicate date, PSI, and tester I.D. Labeling must be impervious to nitromethane and brake clean. All fuels other than nitromethane and methanol prohibited. Artificial cooling and/or heating of fuel prohibited. Nitromethane content restricted to 90 percent maximum. See General Regulations 1:6.

INTAKE MANIFOLD

Accepted setback manifolds: AJPE Stage III 25A-103 or 25A-110, JFR FAM1174 and TBS-500. All other setback manifolds prohibited. Manifold studs must be manufactured per NHRA specifications. If using the TBS-500 a tether is required connecting the two halves of the manifold. Refer to NHRARacer.com for minimum requirements. A current list of NHRA-accepted manifold restraints is available on NHRARacer.com. Manifold burst panel(s) meeting SFI Spec 23.1 mandatory. If single panel is used, total area of rupture disk must equal or exceed 10 square inches. If multiple panels are used, total area of rupture disks must equal or exceed 12 square inches. Panels may be installed in the front and back, or on each side, of manifold. Only one panel per opening permitted unless running the AJPE Stage III 25A-103 or 25A-110, a maximum of one of the 10.75-inch openings may utilize double panels or be blocked off. See General Regulations 1:10.

OIL LINES

Rear main oil feed line, if installed, must be stainless steel. All flexible-pressure oil lines, excluding return lines and any line 30psi or lower in pressure, must use a factory-crimped connection and be pressure-tested and labeled. All testing must be hydrostatic for minimum 30 seconds at 750psi. Label must indicate date, PSI, and tester I.D. Labeling must be impervious to nitromethane and brake clean. Otherwise hard line mandatory. Oil lines must be protected from blower belt by use of a guard. When the oil filter and/or dry-sump tank is mounted separate from the engine, oil lines must have a minimum 1-inch free travel. The use of automotive-type screw-on canister oil filters is prohibited.

OIL-RETENTION DEVICE

Engine oil-retention pan mandatory. Minimum material, .050-inch aluminum or .040-inch carbon fiber/Kevlar. Pan must extend rearward of the motor plate a minimum of 3 inches to capture oil from rear main seal. Pan length from motor plate forward must extend a minimum 3 inches forward of the front face of the lower pulley. A longer pan to provide improved oil retention is acceptable; however, pan must not extend under driver's seat or provide air passages that would be considered enhanced ground effects. Pan may be no wider than outside edge of the bottom frameroils and must extend to the top of the upper frameroils. Pan must be either a one-piece design or constructed as to be sealed as a retention device to retain oil. Must have minimum 4-inch-high bulkhead on front and minimum 2-inch-high bulkhead on rear for oil retention during acceleration and deceleration. Bulkheads must be "coved" toward oil pan to assist oil in staying within the confines of the bulkheads. A nonflammable, oil-absorbent liner mandatory inside of retention device. All holes, cracks, or other openings must be plugged to prevent oil from leaking out of oil-retention pan.

PAN PRESSURE SHUTOFF SYSTEM

An Electrimotion Pan Pressure Shutoff System Kit (part number PK 01) or an Electrimotion Pan PSI Kit (part number PS 15) connected directly to the mandatory Electrimotion Funny Car Safety Shutoff Controller Kit (part number SB001FC, SB002FC, or CM3.0) is mandatory on all cars. All of these components must be properly installed per the manufacturer's instructions and fully operational. Maximum setting for the pan pressure switch is 9 PSI. Any attempt to circumvent the function of any of these devices is strictly prohibited.

SUPERCHARGER

Restricted to Roots-type supercharger, rotor helix angle not to exceed that of a standard 71-series GM-type rotor. Turbocharger and/or centrifugal supercharger prohibited. Maximum size: 14-71, 22 5/16-inch case length, 11 1/4-inch case width, 19-inch rotor length; maximum rotor diameter: 5.840 inches including fixed stripping. The top opening may not exceed 11.750 inches in length or 4.600 inches in width. The case must have removable front and rear bearing end plates; rotor must be contained within one-piece case. Inlet/outlet cavity permitted on front plate only, restricted to maximum 1 inch, measuring from face of bearing plate to the back of the cavity. Cavities are not allowed on rear plate. Spacer or components between top of supercharger case and bottom of hat restricted to 2-inch maximum. Spacer and components may be constructed of aluminum or composite materials only. Variable multi-speed supercharger devices prohibited. Supercharger restraint system meeting SFI Spec 14.3 mandatory. Supercharger restraint straps must be covered with a fire-resistant material. Belt guard

mandatory to shield fuel/oil lines and to prevent damage to oil retention pan. See General Regulations 1:10, 1:11.

THROTTLE

Throttle control must be manually operated by driver's foot: Electronics, pneumatics, hydraulics, or any other device may in no way affect the throttle operation. The following is an exception to this rule: In an effort to reduce oildowns, parameters that indicate imminent engine failure (e.g., pan pressure, etc.) may be used to activate a system capable of pushing the throttle pedal to the closed position. All systems performing this type of function must be approved by the NHRA Technical Department. An NHRA-accepted mechanical device for controlling engine rpm during burnouts may be attached to the injector or throttle linkage but may not be driver controlled. See General Regulations 1:12.

VALVE COVERS

Must be fabricated steel, titanium, or aluminum (no cast or composite permitted) and NHRA-accepted. Must be installed using 5/16-inch steel studs (4130 minimum) and steel or titanium nuts. Titanium valve covers must be SFI Spec 14.4, aluminum or steel valve covers must have SFI Spec 14.4 blanket.

VENT TUBE BREATHERS

Catch can/vent tube system mandatory. Twist-on/quick-disconnect fittings between the vent tube hoses and the valve cover vent tube adapters must incorporate a secondary locking device such as a hasp pin, ball lock pin prohibited. Tape is not a satisfactory primary or secondary locking device. Double clamps are required on each end of all hoses used in the vent system, including the dry-sump vents. Double O rings required at each breather hose to valve cover attachment. Minimum 1 1/4-inch inside diameter hoses are required from each valve cover to the catch can inlets and/or framersails and from each framerail outlet to both catch can inlets. Minimum catch can(s) capacity is an eight-quart sump (i.e., below the bottom baffle). Catch cans must have adequate internal baffling. Minimum catch can inlet configuration is two 1 1/8-inch inside diameter (or equivalent area) tubes. Minimum catch can outlet/discharge configuration is two 1 1/8-inch inside diameter openings (or equivalent area). NHRA-accepted vent tubes/hoses are mandatory for all connections; see NHRARacer.com for a list of accepted vent tubes/hoses. See General Regulations 1:13.

DRIVETRAIN: 2

CLUTCH, FLYWHEEL, FLYWHEEL SHIELD

Flywheel and clutch meeting SFI Spec 1.3 and flywheel shield meeting SFI Spec 6.2 mandatory. Maximum depth of flywheel shield: 9.4 inches (inside). Maximum six clutch discs permitted. Aluminum flywheels prohibited. Clutch exhaust filter mandatory. Refer to General Regulations 2:3, 2:5, 2:6, 2:7 and SFI Spec 10.1 for complete motor plate and bellhousing guidelines.

DRIVELINE

Anti-blowback device mandatory. See General Regulations 2:1.

DRIVELINE COVER

Each end of driveshaft must have a full 360-degree cover of minimum 1/16-inch steel or 1/8-inch aluminum. Rear cover must surround the coupler. Front cover must surround the driveshaft from the back of the reverser to the end of the splicer sleeve in the area of the driver's legs. All covers must be securely mounted to frame, suitable crossmember, reverser, or third member.

REAR END

Rear-end gear ratio restricted to 3.20:1 only; may not be higher or lower. Aftermarket full-floating or live axle assembly mandatory. Periodic maintenance must be performed per manufacturer's requirements. Front-loading or pumpkin-style rear end prohibited at all national events. See General Regulations 2:11. All hubs must be drive hub type and must mate with required drive-hub-type wheel.

REVERSER

Reverser mandatory. Neutral lockout release pin mandatory.

REVERSER COVER

A one-piece tunnel, covering the reverser and driveshaft, mandatory. Must extend from rear of bellhousing back to within 2 inches of the front of driver's seat and be of titanium of .078-inch-thick minimum, chromoly 4130 of .090-inch-thick minimum, carbon composite of .10-inch-thick minimum, or carbon/titanium of .130-inch minimum. Hole allowed for lever. Must include minimum 1-inch horizontal, mounting flange at edges of tunnel. Mounting to chassis floor X member, minimum four places, 5/16-inch steel or titanium bolts mandatory.

REVERSER PIN

Tether attached to reverser pin mandatory. Tether must release pin from reverser mechanism and be accessible without removing the reverser cover. All reversers must be equipped with a pneumatically operated neutral lockout release pin. Installation must be such that the driver can easily and quickly release the pin with all safety equipment in place.

REVERSER SHIELD

A one-piece ballistic shield covering all units mandatory. Must meet SFI Spec 4.1. See General Regulations 2:13.

TRANSMISSION

Transmission prohibited. See General Regulations 9:7.

BRAKES & SUSPENSION: 3**BRAKES**

Automated and/or secondary braking systems prohibited: Application and release of brakes must be a function of the driver; electronics, pneumatics, or any other device may in no way affect or assist brake operation. Four-wheel hydraulic disc brakes with dual master cylinder mandatory. Carbon-fiber brake rotors used in conjunction with carbon-fiber specific brake pads (front and rear) mandatory; all other materials prohibited. Steel brake lines mandatory. NHRA-accepted fireproof brake-line covering mandatory on all (front and rear) flexible connection lines. A current list of NHRA-accepted fireproof brake line coverings is available on NHRARacer.com. Brake lines passing engine or blower drive must be shielded. Hand-brake handle must be constructed of minimum 5/16-inch-thick by 1-inch-wide aluminum, steel, or titanium. Lightening of hand-brake handle (i.e., holes, machining, etc.) prohibited. See General Regulations 3:1.

STEERING

Commercially available quick-disconnect steering wheel meeting SFI Spec 42.1 mandatory. Plating of steering components prohibited.

SUSPENSION

Front and rear suspension prohibited. Steel or aluminum front-spindle assembly mandatory, minimum 4130 steel. All other materials prohibited. Plating of front suspension components prohibited. See General Regulations 3:4.

WHEELIE BARS

Mandatory; must be functional. Steel and titanium wheelie bars permitted, carbon fiber prohibited. Wheels must be nonmetallic. See General Regulations 3:6.

FRAME: 4**BALLAST**

Permitted. Must be secured with minimum of two 1/2-inch or four 3/8-inch Grade 8 fasteners per 100 pounds and be NHRA-accepted.

GROUND CLEARANCE

Minimum 3 inches from front of car to 12 inches behind centerline of front axle, 2 inches for remainder of car, except oil pan and exhaust headers. See General Regulations 4:7.

MOUNTING HARDWARE

See General Regulations 4:7.

HELMET SHROUD

All vehicles in Funny Car must have a rear roll-cage shroud. A one- or three-piece shroud is permitted. The shroud must be constructed of minimum .075-inch Grade 2 ASTM-B-265 titanium or .090-inch 4130 steel and must be shaped to conform to the roll cage. The shroud must be attached to each of the side bars with a minimum of three 1/4-inch-minimum-diameter Grade 8 bolts and bosses per side, to the top with one 1/4-inch minimum diameter Grade 8 bolt and boss, and the rear bars with a minimum of two 1/4-inch-minimum-diameter Grade 8 bolts and bosses per side. Bolts must be 6-point hex-style heads. Tabs with bolt and nut, where the nut is welded to the tab, may be used in place of the bosses. Three-piece shields must be made with two side shields and a center section.

The shroud must be installed flush with or be filled/sealed to the upper roll-cage bars and shoulder hoop so that protective equipment cannot catch between the shroud and the roll-cage components. Absolutely no components may be mounted to the helmet shroud or deflector plate above the top of the shoulder hoop. Bolt heads must be 1/2-inch hex-style head.

PARACHUTE

Dual parachutes mandatory. Two separate shroud line mounting points mandatory with sleeved 1/2-inch-minimum Grade 8 steel bolts with self-locking nuts or with nuts welded onto parachute brackets. Shroud line mounting brackets must be constructed of minimum 3/16-inch 4130 steel or titanium. Shroud lines must be covered with 1/16-inch-thick leather or NHRA-accepted material from mounting point into the pack. Two NHRA-accepted parachute tethers are required and must be routed through each shroud line end loop and be attached using the rear end mounting bolt(s) on each side. The mounting attachments on each end of both tethers must attach to either separate rear end mounting bolts or opposite ends of a single bolt (one under the head of the bolt and the other under the nut). NHRA-accepted parachute tethers: Amick Race Car Restraints PARA-101REV1, Future Fibres FF30MLB-P-MB, or Taylor Motorsports 108. When Future Fibres FF30MLB-P-MB is used, only one tether is required and must be routed through each shroud line end loop and be attached using the rear end mounting bolt on each side. All tethers must be covered with a fire-resistant material. Two separate release cables mandatory. Parachute mounting box must be NHRA-accepted prior to competition. The parachute floor must be flat and may not extend more than 6 inches rearward or beyond the parachute pack, whichever is less. The measurement will be taken from the mounting point on the

rear of the body. The use of a wicker prohibited. See General Regulations 4:8.

BODY MOUNT TREE

Body mount tree must be constructed of 4130 steel or titanium.

ROLL CAGE

Chassis must meet SFI Spec 10.5. Chassis must be recertified yearly by NHRA and have serialized sticker affixed to frame before participation. All wiring must be external of the frametrails; routing of cables, hydraulic or pneumatic lines inside the chassis is permitted. See General Regulations 4:4, 4:11, 10:6.

ROLL-CAGE PADDING

Roll-cage padding meeting SFI Spec 45.2 mandatory anywhere driver's helmet may come in contact with roll-cage components during tire shake or an accident. Additional padding meeting SFI 45.2 is also required around the steering column to protect the driver's knees during an accident. See Accepted Products/ Roll Cage and Steering Column Padding on NHRARacer.com for an example of roll-cage and steering column padding. All roll-cage and steering column padding must be accepted by NHRA officials.

WHEELBASE

Minimum, 124 inches; maximum, 125 inches; measured on long side. Maximum wheelbase variation from left to right: 2 inches. Rear tread width cannot be outside of body line nor more than 3 inches inside body line. Front tread width must be no more than 6 inches inside body line. Measurements will be taken from outside edge of tire to inside edge of body.

TOW-STRAP HOOPS

All cars must have tow-strap hoops on the lower front of the chassis. Hoops must be capable of accepting a 2-inch tow hook without lifting the body and not stressing the body when the car is being towed. Hoops must line up with the centerline of the car, below the body-release rod and clearly marked on the body with an arrow pointing down.

TIRES & WHEELS: 5

TIRES

Vehicle must be equipped with all four tires bearing the same tire manufacturer's brand name. Restricted to Goodyear-only tires as specified by NHRA. Manufacturer name, logo, and tire identification markings must be unaltered and as provided by tire manufacturer, and visible on all four tires at all times. Tires are to meet size requirements when installed and ready to run at manufacturer's recommended operating pressures. All drive tires must either be, or have been, generally available to all competitors. Tires that are currently being provided by the manufacturer, the manufacturer's representative, or other commercial entity must be available to all competitors within that category. Minimum tire pressure at start of run 6psi. See General Regulations 5:1.

WHEELS

Front wheels meeting SFI Spec 15.2 mandatory. Beadlock 16-inch rear wheels meeting SFI Spec 15.4 mandatory; inner bead minimum 14 3/4 inches (+/- 1/8-inch). All wheels must be drive hub type and must mate with required drive type hub. Any modifications and/or lightening, unless performed by the manufacturer, prohibited. Must be completely isolated from driver compartment. Wire wheels prohibited. Rear-wheel discs or covers prohibited. Wheels must conform to applicable tire-manufacturer requirements. Any modifications and/or lightening prohibited. Titanium wheel studs prohibited.

INTERIOR: 6**SHEET METAL**

Driver compartment interior, firewall etc. must be aluminum or steel, magnesium or carbon fiber prohibited.

SEAT

Seats must be foamed with energy-absorbing material and formed to the driver of the vehicle's body. The seat must make contact with the driver's entire back, buttocks and upper thighs and be accepted by NHRA officials. Minimum one-layer, flame-retardant-material type mandatory as seat upholstery. Driver seat bucket must be aluminum, steel, or carbon fiber, magnesium prohibited.

BODY: 7**AIRFOILS, WINGS**

Prohibited.

BODY

A 2000 or later model-year NHRA-accepted coupe or sedan body of a type originally mass-produced by automobile manufacturer (domestic or foreign). Must have originally measured 63 inches wide or more at centerline of front and rear axle. Maximum body and/or roof width cannot exceed stock dimensions. Duplications of production bodies of fiberglass or carbon fiber permitted. Body may be lengthened or shortened. Front and rear contour of body must resemble same configuration and design for specific body used; holes for air passage prohibited. Any new body designs, plans, pictures, specifications, or concepts must be submitted to the NHRA Technical Department for approval. All new body designs or concepts must receive final approval from NHRA on or prior to Dec. 15 of the preceding year or shall be deemed disapproved. Body specifications may vary for certain exhibition vehicles; prior NHRA approval necessary. Any modification to body not described in this Rulebook prohibited.

BODY SPECIFICATION

Maximum body width variation from front to rear is 6 inches. Minimum body width is 60 inches when mounted. Modification to the lower, rear corner of the front wheel opening(s) may be allowed, IF required to meet the clearance for starting-line timing lights. In side view, the body should present clearance, all the way across the car, 3 inches from the ground, extending for a length of 12 inches + 1/4-inch max, rearward from the front spindle centerline. Any exposed edges or openings as a result of trimming the wheel-opening corner should be patched and refinished. Such modifications must be authorized in advance by the NHRA Technical Services Department and accepted upon completion. Bodies are measured at centerline of front and rear axles. Fender flares or lips, maximum 1.5-inch permitted on forward half of front and 1-inch on the rear wheel openings; may not extend rearward of spindle or axle centerlines; must be defined from body. Lips must be mounted in line with wheel opening, and may not be mounted in front of opening. Both the 1-inch and 1.5-inch flares will not be considered in any width measurement. A body header flange lip is allowed and can measure a maximum of 1 inch or as wide as the body, whichever is less. Enclosing the wheelwells or the use of wheel fairings is prohibited. Front and rear wheelwell must maintain OEM radius and contour, and be accepted by NHRA at the time of the body approval. Wheelwell openings: front, minimum 5 inches measured vertically from centerline of the front axle to wheelwell opening; rear, minimum 8 inches measured vertically from centerline of rear axle to wheelwell opening. Trailing edge of rocker minimum 18 inches measured directly from centerline of

rear axle. Front overhang not to exceed 40 inches from centerline of front axle. Beltline moldings (if on stock vehicle), headlight and taillight housings or indentations must be incorporated into body. Headlights and taillights must be painted or decaled to simulate OEM appearance and configuration. Taillight area may be hinged (top only) for air venting, maximum 100 square inches. On each side, maximum two flaps, that must be adjacent, accepted. The hinged openings must include the taillight and must be rectangular in shape; any other holes in rear of body prohibited. Hood scoops prohibited; injector must protrude through hood. Maximum height of hood cowlings 5 inches, may be no wider than base of A-pillars.

Roofs may be chopped maximum 2 inches. Complete removal of roof prohibited. Minimum roof width 32 inches. Minimum width at A-pillar 48.75 inches; minimum width at C-pillar 49.50 inches. Length of roof as measured from top of front windshield to top of rear window must remain within 4 inches of stock. Rocker panel extensions may not be more than 1 inch wide. All bodies run in competition must be run as they come from NHRA-approved molds. Modifications for header clearance will be permitted if authorized in advance by the NHRA Technical Services Department. Bodies will be clean of bumper roll pans or any other component(s) that are in NHRA's determination unnecessary to the normal mounting tubing, firewall, and driver enclosure. No underbody streamlining will be permitted. Ground effects of any description prohibited. Ground effects include but are not limited to rocker skirts, belly pans, sheet-metal work under the body that produces a "tunnel" for the passage of air, etc. Rub bar/splitter cannot extend beyond the inside body line or be greater than 1/2-inch thick. One naca duct permitted in the belly pan, must be covered in such manner that will prevent debris from potentially contacting driver. Maximum width of opening for blower, 26 inches. Opening for blower hat must have a minimum 2.500-inch clearance between body and throttle linkage, clearance not included in 26-inch dimension. Wicker permitted on front and sides of blower opening; maximum height 1 inch. Wicker must be installed 90 degrees to the body and must be a flat surface. Final determination on all body modifications rests with NHRA Technical Services Department.

BODY, BURST PANEL

Body (hood) burst panel(s), minimum 288 square inches, mandatory. Body burst panel(s) must be secured with plastic screws or tie wraps 1/8-inch maximum width. Only one tie wrap per connection point permitted. Six connection points maximum. Two NHRA-accepted body burst panel tethers, with separate body pads for each of the two tethers bolted with a plate on both sides of panel(s). NHRA-accepted body burst panel tethers: Amick Race Car Restraints part number JF-101. Taping of body burst panel(s) permitted along front leading edge only, all other sides prohibited. Maximum 1-inch-wide strip of tape allowed on burst panel.

BODY, FASTENERS AND STIFFENERS

All bolts and fasteners on body, windows, etc. must have button heads toward outside of body. All stiffeners must be placed on the inside of the body, whether on windows, spoiler, etc. A minimum of 6 (3 per side) doublers must be utilized on the mounting tree attachment points connecting the main saddle support structure to the body forward of the 'A' pillar. The 6 mounting tree attachment points do not include attachment to the front latching system. The framing must be a permanent fixture, with the exception of vertical mounts, which can be adjustable for necessary vertical body positioning.

BODY, FLAME-RETARDANT COVERING

Underside of body, including any roof area and all the composite components such as timer boxes, etc. must be covered with SFI Spec 54.1 flame-retardant covering or coating. Must be applied according to the manufacturer's specifications and recommendations, and must be applied externally.

BODY, FRONT LATCH AND TETHERING SYSTEM

Bodies must be equipped with two independent NHRA-accepted front-release locking latch assemblies. An optional NHRA-accepted tethering system may be installed in conjunction with dual latching system. Contact NHRA Technical Services Department for design requirements and specifications. No part of the front-release handles may extend beyond the front overhang limit.

BODY, REAR-RELEASE MECHANISM

Bodies must be removable from a rear-release mechanism that must be accessible in the taillight panel area. The rear-release mechanism must be the pin-and-cable type with capability to remove body without pulling pin. The mechanism must be unobstructed and easily visible and not located within 3 inches of any other opening. Release handle must be colored red and of T-handle design with a minimum measurement of 3 inches in length. Contact NHRA Technical Services Department for acceptable design, operation, and installation.

ESCAPE HATCH

A working escape hatch must be installed in top of body to permit easy driver exit; see-through types prohibited. Minimum size, 18 inches x 17 inches. Roof hatch must be permanently attached and hinged at front. All new Funny Car body designs must incorporate, in an area in the rear portion of the roof hatch, a handhold for emergency release.

FIREWALL/DASH

Must be aluminum or steel; magnesium prohibited. Dash may be minimum .040-inch aluminum, firewall minimum .050-inch aluminum. Dash/firewall overlap seam must use a double row of screws, staggered, on maximum 2-inch centers. Minimum fastener requirements are 8-32 screws, aluminum nuts, and 3/4-inch-diameter x 1/8-inch-thick billet washers. Distance from center of hole to edge of panel, 3/4-inch minimum. Distance from top of bellhousing shroud cutout to "V" of firewall, 6 inches minimum. Minimum .050-inch doubler plate permitted. One-piece, .050-inch dash/firewall permitted.

Portion of the firewall between skin of the body and the chassis can be no higher than 15 inches, as measured from the bottom of the rocker panel to the bottom of the firewall. Vertical portion of the firewall must be within +/- 1 degree of the motor plate angle. Forward coving (radius lip that goes forward) is prohibited.

If the bottom of the firewall has a rearward facing radius of 5 inches or more, a 1/2-inch tall by 4 inches deep diffuser must run the full length of the radius and be installed not more than 1 inch from the apex of the initial radius. The rear break point of the lower radius cannot exceed 12 inches from the vertical portion of the firewall.

Firewall must be equipped with fire windows measuring no greater than 25 square inches on either side of firewall in vicinity of valve covers to warn driver of fire. Laminated safety glass or fire-resistant plastics such as Lexan or Plex 70 mandatory.

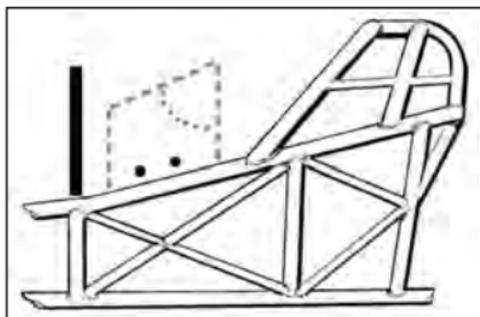

Doghouse fire shielding in driver compartment mandatory; if carbon fiber, must be covered with SFI Spec 54.1 flame-retardant covering or coating. Must seal to clutch cover and to top framerails. Trailing edge of shield should extend to base of steering wheel

and angle toward top of roll cage. Must be mounted with minimum 4 self-locking fasteners (2 on each side). Minimum material, .040-inch aluminum. Hinged top optional.

GRILLE

Must be equipped with a simulated grille of same configuration and design for specific body used; holes for air passage prohibited.

REAR BUMPERS

Must be equipped with rear bumper consisting of a minimum vertical surface of 3 inches, maximum permitted cutout for parachute shroud lines 4 inches by 30 inches. The trailing edge of rear bumper may not extend more than 54 inches from the centerline of the rear axle. Maximum measurement from trailing edge of rear bumper to ground 29 inches at rear tire pressure of 6.0psi. Maximum 1-inch lip permitted on rear bumper as a stiffener, not included in overall measurement.

SPOILERS

Permitted, rear only. Rear spoiler cannot be "built in" to body. Rear deck relocation cannot extend more than one-third of the as-produced replica body's rear window. Side surfaces of elevated decks must be completely covered by spoiler spill plates. Deck area inside spill plates may be no more than 1.75 inches lower than area outside spill plates.

Spoiler surface, front and rear, must be a continuous single-curved plane. Any lips, notches, decks, or steps prohibited in the spoiler surface, except for wickers. Spill plates must consist of vertical planes running parallel to the car. A maximum of two additional supports (ribs or plates) will be allowed anywhere between the spill plates, as long as they are in the vertical plane, running parallel to the spill plates.

If the body is equipped with a rear-spoiler support, which extends from the spoiler to the bumper area and is parallel to the spill plates, a diagonal brace will be allowed. If this brace is to the outside, it must be cut in a straight line, diagonally from the rear of the support to the outside flange of the body.

Maximum rear-spoiler width, including spill plates and attachment points, 54 inches. Rear-spoiler spill plates cannot be located forward of the centerline of the rear axle and onto rear quarter. Spill plates cannot be more than 5 inches above the roof line, or 60 inches from the ground, whichever is LESS. Rearmost point of spill plate may not be more than 60 inches past the centerline of the rear axle. Spill-plate supports permitted on one side of spill plate only, not both. Lip on rear edge of spill plate (vertical), 1/2-inch maximum.

The trailing edge of rear spoiler may not extend more than 56 inches past the centerline of the rear axle, may not be more than 4 inches above the roof line or higher than top of spill plates, whichever is LESS, and the forward and trailing edge may not

be mounted so as to preclude a “wing” configuration. Wicker on spoiler not to exceed 2 inches forward or back. Installation of vortex generators is permitted on the spoiler assembly only; prohibited on car body. Any adjustment or movement during run prohibited. Airflow through spoiler or past the underside of spoiler, other than hinged taillight area, prohibited.

Spoiler may be constructed of composite material, but spill plates must be made of minimum .080-inch magnesium H24 alloy, .090-inch 6061 aluminum, or .150-inch carbon fiber. Any carbon-fiber spill plates must be NHRA-accepted prior to use. Spill plates shall be attached to the body with minimum 8-32 steel screws and aluminum nuts. An aluminum backup washer must be used on the underside of the body, minimum .028-inch thick and 3/4-inch diameter. Spill plates shall be connected by at least one 1/16-inch stainless steel cable looped through a minimum 10-32 (AN42) eyebolt using the proper thimble (AN100) for the size cable used, and crimped with a copper nico press sleeve (cable specs: 7 x 7 strand core, 480-pound breaking strength to Mil Spec Mil-W-83420) and one pair of the same specified cables attaching to the deck of the body. Spill plate must be attached to the body by aluminum nuts. Minimum one 5/16-inch x .035-inch 4130 center wing strut shall be fastened, one end to the body deck, the other to the spoiler, and located in the center of the spoiler width-wise. The attachment bracket on the body to be minimum .063-inch steel secured to the body deck with two 10-32 or three 8-32 steel screws with aluminum nuts. A .028-inch-minimum steel backup doubler must be used under the body to attach the wing strut bracket: 2-inch x 2-inch minimum size.

WINDSHIELD, WINDOWS

Windshield mandatory. Windows optional. Maximum windshield and rear window angle: 3 degrees from stock. Maximum curvature: 2 inches from stock. Rear window and quarter windows (if stock equipped) must be defined by actual route line in body and painted or decaled to simulate glass. Side windows or window openings may be shortened a maximum of 2 inches. Drilling or cutting the windshield or rear window for air passage is prohibited. If windows are used, they must be clear. Side windows must have a minimum 6-inch-diameter opening including liner adjacent to driver. Side windows limited to driver's name, car number, class designation, and decals only. Paint scheme may not extend into these windows. Decals may not completely cover these windows. Outer edge of windows must remain uncovered. NHRA reserves the right to accept or prohibit placement of decals on windows as deemed necessary to comply with this rule. See General Regulations 7:8.

FC

ELECTRICAL: 8

ELECTRICAL COMPONENTS

Electrical and electronic components are restricted to ignition systems, data recorders, electrical gauges or indicators, automated fire extinguisher, fuel system, clutch control, and engine-shutoff system components only. The use of electrical/electronic timers to control pneumatic fuel-system valves, and/or electric fuel control solenoid valves, and/or clutch control valves is permitted. Functions of fuel timers, clutch timers, and ignition system must be initiated by wide-open throttle switch only.

IGNITION SWITCH

Each car in competition must have a positive-action on/off switch, capable of de-energizing the entire ignition system, in good working order, located within easy reach of the driver.

IGNITION SYSTEMS

The use of ignition systems and/or components is limited to those that have been NHRA-accepted for competition. The MSD 89712 Pro Mag Digital Retard Control and MSD 7570 Graphic Editor or MSD 8771 are the only accepted units for NHRA competition.

Any ignition system and/or components other than those specified must be NHRA-accepted prior to usage. Any other attachment prohibited. Ignition systems and/or components must be utilized in an unaltered manner consistent with the manufacturer's installation and instruction books unless otherwise approved. Maximum two spark plugs per cylinder. Spark plug tubes are mandatory and they must be made of stainless steel or aluminum. Removable or pin-type timing pointers prohibited.

ENGINE RPM CONTROLLER

Use of MSD 89712 or 8771 mandatory. Only latest approved firmware permitted.

MAGNETOS

Maximum two magnetos limited to the following models: MSD Pro Mag Systems, 8130, 8140. All competitors must submit magnetos to the NHRA-accepted testing facility (MSD Ignition, Attn: Magneto Repair Department, 1350 Pullman Drive, Dock #14 El Paso, TX 79936). Please contact MSD Customer Service Department at 915-856-2785 to obtain an RMA number before returning magnetos for certification. All magnetos must be certified and sealed by MSD Ignition prior to use in competition. Must maintain OEM pin-out orientation. See NHRARacer.com for pin-out definition.

SUPPORT GROUP: 9**COMPUTER/DATA RECORDER**

Data recorders permitted; must be NHRA-accepted. Accepted systems: Racepak Pro III, Pro II, Pro 1B, and Pro I. Data recorder may be used in conjunction with manufacturer's digital dash display. All Pro III output signals must be approved by NHRA Technical Department prior to use. Ride height sensors permitted; may only be connected to data recorder. See General Regulations 9:1, 9:2.

EVENT DATA RECORDER

Properly installed and operational PRC Systems Event Data Recorder (part number EDR1.0 or EDR 2.0) and PRC Systems Wire Assembly (part number WA1.0 or WA 2.0) mandatory. The PRC Systems Event Data Recorder and Wire Assembly must be installed per the manufacturer's instructions. Modification of or tampering with the PRC Event Data Recorder and Wire Assembly prohibited.

FIRE EXTINGUISHER SYSTEM

Fire extinguishing system must meet SFI Spec 17.1. Minimum 20-pound or more NHRA-accepted fire extinguishing system mandatory. System must be divided so that a minimum of 15 pounds is directed into engine compartment by means of nozzled outlets placed in front of each bank of exhaust headers. Remaining 5 pounds or more should be dispersed in driver compartment by means of an atomizing nozzle placed at driver's feet. Must be installed per manufacturer's specifications with all gauges clearly visible. Fire bottle activation cables must be installed inside framerail where cables pass engine/bellhousing area. Fire-bottle mounting brackets must be constructed of aluminum or steel. Carbon-fiber bottles prohibited.

If equipped with a pneumatic-activated extinguishing system, a manual-activated extinguishing system is mandatory. If a manual-activated extinguishing system is primary, no backup

system is required. See General Regulations 9:3 for NHRA-accepted fire extinguishing agents.

SHUTOFF DEVICE

Properly installed and operational Electrimotion Funny Car Safety Shutoff Controller Kit (part number SB001FC, SB002FC, or CM3.0) and Electrimotion Shutoff Receiver (part number RF001) mandatory. The Electrimotion Funny Car Safety Shutoff Controller Kit must be installed per the manufacturer's instructions.

Modification of or tampering with the Electrimotion Funny Car Safety Shutoff Controller Kit prohibited. The activation of the system override switch by any means other than parachute deployment is prohibited. The Electrimotion Crew Alert Box, part number CB001 and the Motorsports Safety Electronics Shutoff System part number MS1150, may be used in conjunction with the Shutoff Device to illuminate a dash light for driver notification, disengage throttle and/or enable the shutoff device. Any other use of the Electrimotion Crew Chief Alert box or the Motorsports Safety Electronics Shutoff System is prohibited.

TOW VEHICLES

No full-size vehicles allowed in starting-line area; a starting cart mandatory. The maximum starting-cart size can equal that of a standard golf cart without a canopy. Full-size chase vehicles permitted. See General Regulations 9:12.

WARM-UPS

When starting a vehicle in the pit area, vehicle must be fully within the assigned space. No part of the rear tire may extend past the end of trailer. When occupying an "end spot" pit space or if the neighboring trailer does not completely shield your vehicle, it is mandatory to park a tow truck/car alongside the vehicle while engine is running. Vehicle must have a pedal stop that limits the throttle opening to a maximum of 3/4 of wide-open-throttle. Pneumatic throttle devices prohibited. Jackstand devices must provide a minimum ground clearance of 7 inches. See General Regulations 9:5, 9:14.

DRIVER: 10

ARM RESTRAINTS

Mandatory. See General Regulations 10:3.

CREDENTIALS

Valid NHRA competition license mandatory. See General Regulations 10:4.

DRIVER RESTRAINT SYSTEM

Minimum 7-point driver restraint system meeting SFI Spec 16.1 or 16.5 mandatory. Wrapping of belt(s) around framerail or chassis tube prohibited. All shoulder, lap, and leg straps must be mounted to the chassis via mounting brackets that are bolted or welded to the chassis per the manufacturer's instructions. If bracket is bolted through framerail or chassis tube, hole in framerail or chassis tube must be bushed, with bushing completely welded to tube. Whether mounted directly to frame or to a tab welded to the frame, mounting bracket attachment bolt must be in double shear and of shoulder bolt design, so as to permit the bracket to pivot and align toward the direction of pull. All belts must be covered with a fire-resistant covering. Seat belt mounting points must be covered with either sheet metal or an acceptable fire-resistant material. Restraint system must be updated at two-year intervals from date of manufacture. See General Regulations 10:5.

HEAD AND NECK RESTRAINT DEVICE/SYSTEM

At all times that the driver is in the race vehicle, from the ready line until the vehicle is on the return road, driver must properly

utilize an SFI-approved head and neck restraint device/system, including connecting the helmet as required for full functionality of the device. The device/system must meet SFI Spec 38.1 and must display a valid SFI label. The head and neck restraint device/system, when connected, must conform to the manufacturer's mounting instructions, and it must be configured, maintained, and used in accordance with the manufacturer's instructions.

HELMET

Full-face helmet meeting Snell SA2010, or SA2015, FIA 8860-2010, 8860-2015 or 8860-2018 with shield mandatory. Eject Helmet Removal System (part number SDR 890-01-30) mandatory and must be installed per manufacturer instructions. A Stand 21 Lid Lifter head sock meeting SFI 3.3 may be used in lieu of the Eject Helmet Removal System. See General Regulations 10:7.

PROTECTIVE CLOTHING

Driver's suit meeting SFI Spec 3.2A/20, long sleeve underwear shirt meeting SFI 3.3, long underwear pants meeting SFI 3.3, SFI Spec 3.3/20 gloves, glove under-liners made of flame retardant material, SFI Spec 3.3/20 boots, socks meeting SFI 3.3, SFI Spec 3.3 head sock, and SFI Spec 3.3/10 helmet skirt mandatory. A shoe meeting SFI Spec 3.3/20 constructed such that the flame retardant material is at least six inches above the heel may be used in lieu of a 3.3/20 boot. All jacket/pants or suits meeting SFI Spec 3.2A/20 must be recertified on a five-year interval. All clothing containing metal or plastic prohibited. Undergarments that are worn in addition to those mandated that are made of flammable materials (e.g. nylon, rayon, polyester, spandex etc.) are prohibited. All jewelry prohibited. A 3000 PSI, 112 cubic inches minimum capacity fresh air breathing system mandatory. System must be manufactured and installed by the original helmet manufacturer or with written authorization of the original helmet manufacturer. Helmet must meet applicable SFI and/or Snell specs with fresh air system installed. Compressed air only. Air must be supplied by constant pressure. See General Regulations 10:10.



SECTION 19 TOP FUEL DRAGSTER

DESIGNATION

TF, preceded by car number.

Reserved for supercharged, fuel-burning dragsters, built specifically for all-out drag racing competition. Minimum weight at conclusion of run: 2,330 pounds, including driver.

Any competitor who causes an oildown while participating at an NHRA Mello Yello event will be subject to fines and penalties as outlined in Section 2 - Oildown Penalties.

Any proposed changes to vehicle design or vehicle components must be submitted in writing to the NHRA Technical Department for review and approval or disapproval, in NHRA's sole and absolute discretion. Only safety-enhancing modifications will be considered for approval and implementation during 2019. Performance-enhancing modifications may be submitted for approval; however, even if approved for future use, it is NHRA's plan that no performance-enhancing modifications will be implemented during 2019.

Plans for proposed changes to vehicle design or vehicle components and, if practicable, prototypes, must be submitted to the NHRA Technical Department as part of the review process. Fees and costs, if any, incurred by NHRA in determining whether to approve or disapprove the proposed changes to vehicle design or vehicle components shall be borne by the party submitting the items for review. Approval, if granted, is valid only if such approval is granted in writing, signed by the Director of Engineering, Technical Operations. No proposed changes to vehicle design or vehicle components can be used in competition unless such written approval has first been granted.

Proposed changes to vehicle design or vehicle components includes, but is not limited to, engine blocks, cylinder heads, intake manifolds, fuel pumps, superchargers, body components, wing components and electronics, and includes any redesign, reconfiguration, and/or modifications to existing components. It is the participant's responsibility to refer any development, redesign, reconfiguration, and/or modification questions with respect to Top Fuel components to the NHRA Technical Department to determine whether permitted or prohibited before using in competition, and disqualification or other penalties determined in NHRA's discretion may result if this procedure is not followed.

Non-approved parts/components are not permitted on race vehicles at **any time** (including any/all qualifying day(s) and eliminations) during a National Event. If a vehicle is found to be using any item or component that is different from that which is approved, including an item or component that has been modified or altered from the approved configuration, then the driver will be penalized with a deduction of 75 points and the team and/or driver (in NHRA's discretion) will be penalized with a minimum \$25,000 fine. If not paid, the fine may be withheld from any purse/prize monies; if NHRA is unable to collect the fine from purse/prize monies the team may not be allowed to compete again, in NHRA's discretion. Multiple violations and/or flagrant disregard for this policy may result in additional penalties as determined by NHRA in its sole and absolute discretion. Such additional penalties may include disqualification, suspension or loss of season points. Among items and components that are subject to inspection and penalty if found to be different, altered, modified or otherwise not the same as the item or component that is approved, are the following: injector hats; supercharger cases (excluding end plates); supercharger inserts; supercharger rotors; intake manifolds; cylinder heads (intake valve sizes may be increased to 2.470 inches max.); engine blocks; magnetos; ignition systems; data acquisition systems; safety shutoff system; pan pressure shutoff system; event data recorder; front wings; rear wings; tires; and nitromethane.

REQUIREMENTS & SPECIFICATIONS

ENGINE: 1

ENGINE

Any NHRA-accepted, reciprocating, 90-degree V-8, single-

camshaft, automotive-type engine permitted. Multi-valve and/or overhead-cam engines prohibited. Maximum 500 cid; maximum bore center spacing 4.800 inches; maximum cam centerline 5.400 inches, maximum two valves per cylinder. Only one cylinder-head design is acceptable:

Intake valve angle of 35 degrees, + or - 1 degree

Intake valve size maximum: 2.470 inches

Exhaust valve angle of 21 degrees, + or - 1 degree

Combined intake and exhaust valve size maximum: 4.395 inches

Bore size: 4.1875 inches, +.004-inch

Engine block must be forged aluminum and NHRA-accepted.

Dry-sump oil system permitted. Dry-sump tank must be mounted inside framerails. Engine must be equipped with an NHRA-accepted SFI Spec 7.1 lower engine ballistic/restraint flexible type device and SFI Spec 14.4 valve cover blanket. End rail at rear of motor must be covered with ballistic material. A positive method (flange, lip, etc.) must be attached to the intake manifold or engine block to retain both the front and rear manifold to block gasket(s). The flange/lip must extend past the surface of the gasket and be contoured to closely fit the block and manifold surfaces to prevent the gasket from extruding. An inner diaper, Taylor part number 002-ID-TF, NitroSew part number 4028, or DJ Safety part number 750500.wet mandatory. Carbon fiber/composite oil pan prohibited.

EXHAUST SYSTEM

Exhaust must be directed to rear, away from driver. Maximum header pipe O.D. 2.75 inches. O.D. and I.D. must remain constant to the exit of the header. Maximum header pipe length cannot exceed 16 inches measured from the top framerail.

FUEL INJECTOR HAT

Maximum fuel injector air inlet opening: 65 square inches measured at butterfly or throttle bodies, excluding cross shaft in fully open position. The maximum accepted height from the crankshaft centerline to the top of the injector hat is 46.000 inches. The injector hat shall extend forward no more than 10.375 inches from the front of the injector hat to the front left cylinder mounting stud/bolt for the intake manifold to cylinder-head attachment. Maximum throat inlet opening, 65 square inches. Electronic or electrically controlled fuel injection prohibited. Any NHRA-approved modification must be performed by the original manufacturer only.

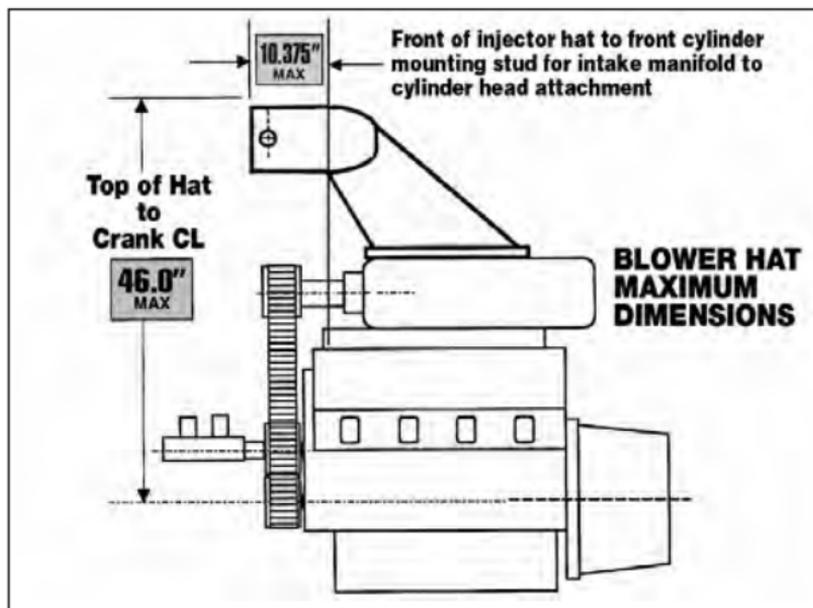

FUEL SYSTEM

Fuel lines must be isolated from driver compartment by a subfloor or housing when engine is located in rear and fuel tank is in front of driver. Fuel gauge lines in the driver compartment must be steel-braided with steel fittings. Pressurized fuel tanks prohibited. Fuel tanks must be mounted above bottom framerail. No fuel may be routed through any frame member on any car. Fuel cells permitted. All fuels other than nitromethane and methanol prohibited. Artificial cooling and/or heating of fuel prohibited. Nitromethane content restricted to 90 percent maximum. Fuel-pump inlet must be of double-barb design. All fuel-inlet fittings must be double-barb or double-bead design and secured with double clamps. Fuel block, down nozzle, and manifold nozzle lines must be located so as to be clear of exit air pressure from manifold burst panel. All flexible fuel-pressure lines, with the exception of the hat nozzle lines, must be pressure tested and labeled. All testing must be hydrostatic for minimum 30 seconds at 750psi. Label must indicate date, PSI, and tester I.D. Labeling must be impervious to nitromethane and brake clean. See General Regulations 1:6.

INTAKE MANIFOLD

Accepted setback manifolds: AJPE Stage III 25A-103 or 25A-110, JFR FAM1174 and TBS-500. All other setback manifolds prohibited. Manifold studs must be manufactured per NHRA specifications. Refer to NHRARacer.com for minimum requirements. If using the TBS-500 a tether is required connecting the two halves of the manifold. Front manifold restraint meeting SFI 14.5 mandatory on JFR FAM1174 intake manifolds. A current list of NHRA-accepted manifold restraints is available on NHRARacer.com. Manifold burst panel(s) meeting SFI Spec 23.1 mandatory. If single panel is used, total area of rupture disk must equal or exceed 10 square inches. If multiple panels are used, total area of rupture disks must equal or exceed 12 square inches. Panels may be installed in the front and back, or on each side, of manifold. Only one panel per opening permitted unless running the AJPE Stage III 25A-103 or 25A-110, a maximum of one of the 10.75-inch openings may utilize double panels or be blocked off. See General Regulations 1:10.

OIL LINES

Rear main oil feed line, if used, must be stainless steel hard line. All flexible-pressure oil lines, excluding return lines and any line 30psi or lower in pressure, must use a factory-crimped connection and be pressure-tested and labeled. All testing must be hydrostatic for minimum 30 seconds at 750psi. Label must indicate date, PSI, and tester I.D. Labeling must be impervious to nitromethane and brake clean. Otherwise hard line mandatory. Oil lines must be protected from blower belt by use of a guard. When the oil filter and/or dry-sump tank is mounted separate from the engine, oil lines must have a minimum 1-inch free travel. The use of automotive-type screw-on canister oil filters is prohibited.

OIL-RETENTION DEVICE

Engine oil-retention pan mandatory. Minimum material, .050-inch aluminum or .040-inch carbon fiber/Kevlar. Pan must extend forward a minimum of 3 inches from the front face of the lower pulley and must extend rearward a minimum of 1 inch past the crossmember under the pinion flange. A longer pan to provide improved oil retention is acceptable; however, pan must not extend forward under driver's seat or provide air passages that would be considered enhanced ground effects. Pan may be no wider than outside edge of the bottom framerails and must extend to the top of the upper framerails. Pan must be

either a one-piece design or constructed as to be sealed as a retention device to retain oil. Must have minimum 4-inch-high bulkheads for oil retention during acceleration and deceleration. Front bulkhead must be reinforced to prevent breakage due to broken blower belt. Bulkheads must be "coved" toward oil pan to assist oil in staying within the confines of the bulkheads. A nonflammable, oil-absorbent liner mandatory inside of retention device. All holes, cracks, or other openings must be plugged to prevent oil from leaking out of oil-retention pan.

PAN PRESSURE SHUTOFF SYSTEM

An Electrimotion Pan Pressure Shutoff System Kit (part number PK 01) or an Electrimotion Pan PSI Kit (part number PS 15) connected directly to the mandatory Electrimotion Top Fuel Safety Shutoff Controller Kit (part number SB001TF, SB002FC, or CM3.0) is mandatory on all cars. All of these components must be properly installed per the manufacturer's instructions and fully operational. Maximum setting for the pan pressure switch is 9 PSI. Any attempt to circumvent the function of any of these devices is strictly prohibited.

SUPERCHARGER

Restricted to Roots-type supercharger, rotor helix angle not to exceed that of standard 71-series GM-type rotor. Turbocharger and/or centrifugal supercharger prohibited. Maximum size: 14-71, 22 5/16-inch case length, 11 1/4-inch case width, 19-inch rotor length; maximum rotor diameter: 5.840 inches including fixed stripping. The top opening may not exceed 11.750 inches in length or 4.600 inches in width. The case must have removable front and rear bearing end plates; rotor must be contained within one-piece case. Inlet/outlet cavity permitted on front plate only, restricted to maximum 1 inch, measuring from face of bearing plate to the back of the cavity. Cavities are not allowed on rear plate. Spacer or components between top of supercharger case and bottom of hat restricted to 2 1/2-inch maximum. Spacer and components may be constructed of aluminum or composite materials only. Variable multi-speed supercharger devices prohibited. Supercharger restraint system meeting SFI Spec 14.3 mandatory. Supercharger restraint straps must be covered with a fire-resistant material. Belt guard mandatory to shield fuel/oil lines and to prevent damage to oil retention pan. See General Regulations 1:10, 1:11.

THROTTLE

Throttle-actuating method on rear-engine cars must be protected where it passes blower-drive section. Throttle control must be manually operated by driver's foot; electronics, pneumatics, hydraulics, or any other device may in no way affect the throttle operation. The following is an exception to this rule: In an effort to reduce oildowns, parameters that indicate imminent engine failure (e.g., pan pressure, etc.) may be used to activate a system capable of pushing the throttle pedal to the closed position. All systems performing this type of function must be approved by the NHRA Technical Department. An NHRA-accepted mechanical device for controlling engine rpm during burnouts may be attached to the injector or throttle linkage but may not be driver controlled. See General Regulations 1:12.

VALVE COVERS

Must be fabricated steel, titanium, or aluminum (no cast or composite permitted) and NHRA-accepted. Must be installed using 5/16-inch steel studs (4130 minimum) and steel or titanium nuts. Titanium valve covers must be SFI Spec 14.4, aluminum or steel valve covers must have SFI Spec 14.4 blanket.

VENT TUBE BREATHERS

NHRA-accepted catch can/vent tube system mandatory. Twist-on/quick-disconnect fittings between the vent tube hoses and the valve cover vent tube adapters must incorporate a secondary locking device such as a hasp pin, ball lock pin prohibited. Tape is not a satisfactory primary or secondary locking device. Double clamps are required on each end of all hoses used in the vent system, including the dry-sump vents. Double O rings required at each breather hose to valve cover attachment. Minimum 1 1/4-inch inside diameter hoses are required from each valve cover to the catch can inlets and/or framerrails and from each framerrail outlet to both catch can inlets. The vent tube must utilize (metallic) hard lines; if soft lines are to be used, the total maximum length is 12 inches divided into two equal lengths located on each end of the hard line. Minimum catch can(s) capacity is 6.75 gallons. Catch cans must have adequate internal baffling. Minimum catch can inlet configuration is two 1 1/8-inch inside diameter (or equivalent area) tubes. Minimum catch can outlet/discharge configuration is two 1 1/8-inch inside diameter openings (or equivalent area). NHRA-accepted vent tubes/hoses are mandatory for all connections; see NHRARacer.com for a list of accepted vent tubes/hoses. See General Regulations 1:13.

DRIVETRAIN: 2**CLUTCH, FLYWHEEL, FLYWHEEL SHIELD**

Flywheel and clutch meeting SFI Spec 1.3 and flywheel shield meeting SFI Spec 6.2 mandatory. Maximum depth of flywheel shield: 9.4 inches (inside). Maximum six clutch discs permitted. The use of aluminum flywheels is prohibited. Clutch exhaust filter mandatory. Refer to General Regulations 2:3, 2:5, 2:6, 2:7, and SFI Spec 2.3 for complete motor plate and bellhousing guidelines.

DRIVELINE

Anti-blowback device mandatory. See General Regulations 2:1.

REAR END

Rear-end gear ratio restricted to 3.20:1 only; may be no lower or higher. Aftermarket full-floating or live axle assembly mandatory. Periodic maintenance must be performed per manufacturer's requirements. Front-loading or pumpkin-style rear end prohibited at all national events. See General Regulations 2:11. All hubs must be drive hub type and must mate with required drive-hub-type wheel.

REVERSER

Reverser mandatory. Neutral lockout release pin mandatory. All reversers must be equipped with a pneumatically operated neutral lockout release pin. Installation must be such that the driver can easily and quickly release the pin with all safety equipment in place.

REVERSER SHIELD

A one-piece ballistic shield covering all units mandatory. Must meet SFI Spec 4.1. See General Regulations 2:13.

TRANSMISSION

Transmission prohibited. See General Regulations 9:7.

BRAKES & SUSPENSION: 3**BRAKES**

Automated and/or secondary braking systems prohibited: Application and release of brakes must be a function of the driver; electronics, pneumatics, or any other device may in no way affect or assist brake operation. Dual spots or equivalent

oval pucks mandatory; minimum two rear-wheel hydraulic disc brakes. Carbon-fiber brake rotors used in conjunction with carbon-fiber specific brake pads mandatory; all other materials prohibited. Hand brake, if used, must be located inside body or driver compartment. Steel brake lines mandatory. NHRA-accepted fireproof brake-line covering mandatory on all flexible connection lines. A current list of NHRA-accepted fireproof brake line coverings is available on NHRARacer.com. Brake lines passing engine or blower drive must be shielded. Hand-brake handle must be constructed of minimum 5/16-inch-thick by 1-inch-wide aluminum, steel, or titanium. Lightening of hand-brake handle (i.e., holes, machining, etc.) prohibited. See General Regulations 3:1.

STEERING

Commercially available quick-disconnect steering wheel meeting SFI Spec 42.1 mandatory. A device must be used to prevent a long steering shaft from injuring driver in case of frontal impact. Plating of steering components prohibited. See General Regulations 3:3.

SUSPENSION

Front and rear suspension prohibited. Steel front-spindle assembly mandatory, minimum 4130 steel. All other materials prohibited. Plating of front suspension components prohibited. See General Regulations 3:4.

WHEELIE BARS

Mandatory; must be functional. Steel and titanium wheelie bars permitted, carbon fiber prohibited. Wheels must be nonmetallic. See General Regulations 3:6.

FRAME: 4

BALLAST

Permitted. Must be secured with minimum of two 1/2-inch or four 3/8-inch Grade 8 fasteners per 100 pounds and be NHRA-accepted. See General Regulations 4:2.

HELMET SHROUD/DEFLECTOR PLATE

All vehicles in Top Fuel must have a rear roll-cage shroud. A one-, two-, or three-piece shroud is acceptable. The shroud must be constructed of minimum .075-inch Grade 2 ASTM-B-265 titanium or .090-inch 4130 steel and must be shaped to conform to the roll cage. The shroud must be attached to each of the side bars with a minimum of three 5/16-inch Grade 8 bolts and bosses per side, to the top with one 5/16-inch Grade 8 bolt and boss, and to the rear bars with a minimum of two 5/16-inch Grade 8 bolts and bosses per side. Bolt heads must be 1/2-inch hex-style head; no clearance slots allowed. Tabs with bolt and nut, where the nut is welded to the tab, may be used in replace of the bosses.

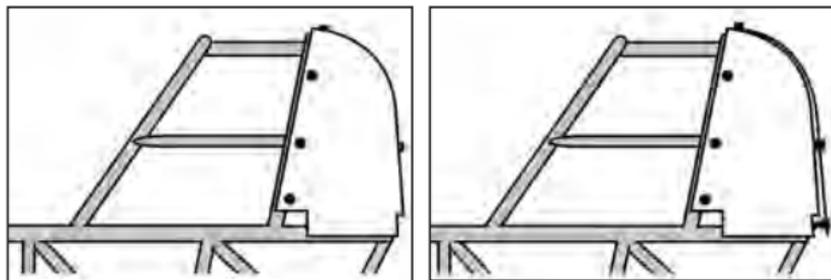

NHRA-accepted helmet shrouds must be made as a one-piece shroud, a two-piece shroud, where each half must overlap; or a three-piece shroud, that includes two side shields and the center section.

All shrouds must fully encapsulate the rear braces and the secondary roll-cage hoop on the sides and top; when viewed from the rear, the shroud must cover the complete visible roll-cage structure. On the bottom, the entire shroud must extend fully down to the centerline of the shoulder hoop; on the top and sides, the entire shroud must extend fully forward to at least the centerline of the side bars.

When the shroud is fabricated as a two-piece unit, the components must overlap a minimum of 3/4-inch per side.

On a three-piece shroud, the center/rear section of the shroud may stand off from/behind the side pieces by no more than 3/4 inches at any point and must overlap each side a minimum of 1 1/2 inches. The side shrouds must extend to the centerline of the rear hoops.

The shroud must be installed flush with or be filled/sealed to the upper roll-cage bars and shoulder hoop so that protective equipment cannot catch between the shroud and the roll-cage components. Absolutely no components may be mounted to the helmet shroud or deflector plate above the top of the shoulder hoop.

A deflector plate, minimum 1/8-inch 6061 T6 aluminum or 1/16-inch steel or titanium, must be installed between roll cage and engine. The deflector plate must extend from 1 inch above top blower pulley to 1 inch below bottom pulley and be a minimum 10 inches wide from shoulder bar to highest point. On any enclosed engine/driver configuration, a full bulkhead must be installed to completely seal driver from the engine. Minimum attachment for any plate is four 5/16-inch Grade 8 bolts. See General Regulations 4:3.

All deflector plates must be stamped by manufacturer of the bulkhead to certify that the proper material was used. The stamp must be in a location for easy inspection.

GROUND CLEARANCE

Minimum 3 inches from front of car to 12 inches behind centerline of front axle; 2 inches for remainder of car, except oil pan.

MOUNTING HARDWARE

See General Regulations 4:7.

PARACHUTE

Dual parachutes mandatory. Two separate shroud line mounting points mandatory with sleeved 1/2-inch-minimum Grade 8 steel bolts with self-locking nuts or with nuts welded onto parachute brackets. Shroud line mounting brackets must be constructed of minimum 3/16-inch 4130 steel or titanium. Shroud lines must be covered with 1/16-inch-thick leather or NHRA-accepted material from mounting point into the pack. Two NHRA-accepted parachute tethers are required and must be routed through each shroud line end loop and be attached using the rear end mounting bolts on each side. The mounting attachments on each end of both tethers must attach to either separate rear end mounting bolts or opposite ends of a single bolt (one under the head of the bolt and the other under the nut). NHRA-accepted parachute tethers: Amick Race Car Restraints PARA-101REV1, Future Fibres FF30MLB-P-MB, or Taylor Motorsports 108. When Future Fibres FF30MLB-P-MB is used, only one tether is required and must be routed through each shroud line end loop and be attached using the rear end mounting bolt on each side. All tethers must be covered with a fire-resistant material. Two

separate release cables mandatory. See WINGS & SUPPORTS. See General Regulations 4:8.

ROLL CAGE

Chassis must meet SFI Spec 2.3 (rear-engine cars). Chassis must be recertified yearly by NHRA and have serialized sticker affixed to frame before participation. Cars without crossmember above driver's legs must have a strap or device to prevent legs from protruding outside chassis. All wiring must be external of the framerails; routing of cables and hydraulic or pneumatic lines inside the chassis is permitted. See General Regulations 4:4, 4:11, 10:6.

ROLL-CAGE PADDING

Roll-cage padding meeting SFI Spec 45.2 mandatory anywhere driver's helmet may come in contact with roll-cage components during tire shake or an accident. See Accepted Products/Roll Cage and Steering Column Padding on NHRARacer.com for an example of roll-cage padding. All roll-cage padding must be accepted by NHRA officials.

SKID PLATES

Skid plates attached to motor plate or frame mandatory. Must be at least 3 square inches in contact area, located below the bottom of the oil pan, and designed to come in contact with the ground before the framerail. Wheels are not permitted in lieu of skid plates.

WHEELBASE & FRONT TREAD WIDTH

Minimum: 280 inches. Maximum: 300 inches on long side. Maximum wheelbase variation from left to right: 2 inches. Minimum front tread width 26 inches.

TIRES & WHEELS: 5**TIRES**

Vehicle must be equipped with all four tires bearing the same tire manufacturer's brand name. Restricted to Goodyear-only tires as specified by NHRA. Manufacturer name, logo, and tire identification markings must be unaltered and as provided by tire manufacturer, and visible on all four tires at all times. Tires are to meet size requirements when installed and ready to run at manufacturer's recommended operating pressures. All drive tires must either be, or have been, generally available to all competitors. Tires that are currently being provided by the manufacturer, the manufacturer's representative, or other commercial entity must be available to all competitors within that category. Minimum tire pressure at start of run 6 1/2psi. See General Regulations 5:1.

WHEELS

Front wheels meeting SFI Spec 15.2 mandatory. Beadlock 16-inch rear wheels meeting SFI Spec 15.4 mandatory; inner bead minimum 14 3/4 inches (+/- 1/8-inch). All wheels must be drive hub type and must mate with required drive type hub. Any modifications and/or lightening, unless performed by the manufacturer, prohibited. Wire wheels prohibited. Rear-wheel discs or covers prohibited. Wheels must conform to applicable tire-manufacturer requirements. Minimum diameter on front wheels 17 inches. Any modifications and/or lightening prohibited. Titanium wheel studs prohibited.

INTERIOR: 6**SEAT**

Seats must be foamed with energy-absorbing material and formed to the driver of the vehicle's body. The seat must make contact with the driver's entire back, buttocks and upper

thighs and be accepted by NHRA officials. Minimum one-layer, flame-retardant-material type mandatory as seat upholstery. Driver seat bucket must be aluminum, steel, or carbon fiber, magnesium prohibited.

BODY: 7

BODY

Body and cowl must be metal, fiberglass, or carbon fiber/Kevlar. Driver compartment, frame structure, roll bars, and body must be designed to prevent driver's body or limbs from contacting track surface. Subflooring, inside but independent of body, mandatory. Subflooring must not contain openings or gaps. Front overhang not to exceed 30 inches, measured from centerline of front spindle to forwardmost point of car. Rear body panels must cover top and bottom framerail and extend at a minimum 19 inches from the centerline of the rear axle forward.

Ground effects of any description prohibited. Ground effects include, but are not limited to, rocker skirts, belly pans, sheet-metal work under the body that produces a "tunnel" for the passage of air, etc. Air deflector plates located behind cockpit restricted to maximum 17 inches by 17 inches. Leading edges, fairing in, or rounding off corners, etc. prohibited. Maximum 1.25-inch lip for stiffening permitted. Mud flap may be located in front of or behind exhaust headers.

CANOPY

Aerodine Top Fuel canopy (consisting of ACG12A132 Top Fuel Canopy Composite Assembly and ACG12A133 Top Fuel Canopy Mechanical/Mounting Kit) permitted. Canopy must be installed per manufacturer's instructions.

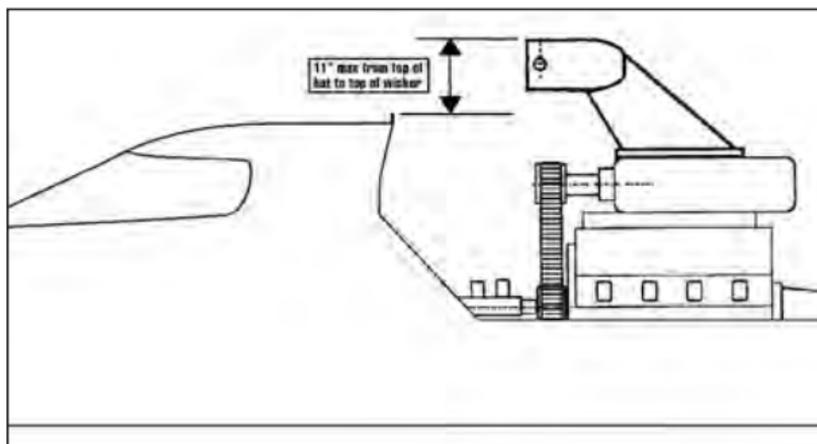

Any car with a canopy must have a 3000 PSI, 112 cubic inches minimum capacity fresh air breathing system. Fresh air system must be manufactured and installed by the original helmet manufacturer or with written authorization of the original helmet manufacturer. Helmet must meet applicable SFI and/or Snell specs with fresh air system installed. Compressed air only. Air must be supplied by constant pressure (see General Regulations 9:8).

Any car with a canopy must have an NHRA-accepted 5-pound fire extinguishing system meeting SFI Spec 17.1. Must be installed per manufacturer's specifications with all gauges clearly visible. Fire-bottle activation cables must be installed inside framerail where cables pass engine/bellhousing area. Fire-bottle mounting brackets must be constructed of aluminum or steel. Carbon-fiber bottles prohibited. See General Regulations 9:3.

Punch-out fire window score lines may not be covered by vinyl covering. Punch-out panels must be well-marked and visible at night.

Relationship of injector hat to canopy wickerbill must meet requirements shown in the accompanying figure.

FRONT-WHEEL FAIRINGS

Prohibited.

WINDSCREEN

Mandatory. The windscreen or deflector must be designed to divert wind, liquids, and foreign matter over the driver's head, be securely mounted, and installed in such a manner that it does not obstruct the driver's frontal view in any way. The windscreen/deflector should be as high as possible without restricting the driver's vision. Windscreen minimum angle and opening must meet requirements shown in the accompanying figure. See General Regulations 7:7.

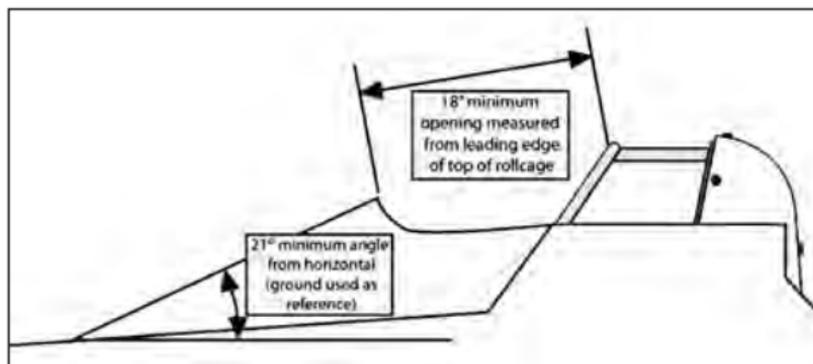

WINGS & SUPPORTS

Rear wing supports must meet SFI Spec 2.3. Rear wing must meet SFI Spec 49.1. SFI tag must be affixed to the main wing element, on the underside, adjacent to the right spill plate. Wing configuration limited to one only, with three elements, and must be NHRA-accepted for competition. Combined total area of rear wing (total of all stages and/or elements) is restricted to a minimum 1,450 square inches and a maximum of 1,500 square inches. Trailing edge of rear wing may not extend more than 50 inches behind centerline of rear axle. Maximum height of any wing as measured vertically from the trailing edge of wing to ground is 90 inches. Strut mounting points may not be forward of motor plate. Distance from main to secondary mounting points must be 30 inches minimum. No part of the wing or wing supports may attach to any engine, bellhousing, or transmission components. Main strut to chassis fasteners 7/16-inch, Grade 5 minimum; adjusting rod fasteners 5/16-inch, Grade 5 minimum; all other wing fasteners 3/8-inch, Grade 5 minimum. Ball-lock pins prohibited for attachment. Any adjustment or movement during run prohibited.

Spill plates must be flat, vertical, and inner and outer surfaces must be parallel. Maximum thickness including trailing edge of wicker 0.650-inch. Wicker permitted on trailing edge only. Must be flat/straight, not to exceed 31 inches measured diagonally from the front leading edge at the bottom of the spill plate to the top trailing edge at the back of the spill plate. Lips of any other kind prohibited. Spill plate must attach to wing or airfoil at right angle, radius at joint prohibited. Spill plates must fit within the confines of a 22-inch by 22-inch square box.

For all cars, an independent cable must be wrapped around each end of the main element of the rear wing and be connected to both parachute release cables such that if the main element separates from the support structure or if either end of the main element is broken off, both parachutes will automatically deploy. The cables must be wrapped around the main element on the outside of the support structure and be

secured (i.e., taped, hardwired, etc.) to the main element to keep the cables from sliding on the wing.

Top Fuel rear wing main element limited to a maximum positive 2-degree angle and a minimum negative 2-degree angle relative to the racing surface. The only exception is in Denver where there is no maximum. Rear wing must remain unaltered from manufacturer's specs.

FRONT WINGS

Front wing must meet SFI Spec. 49.2. Front-wing design must be NHRA-accepted prior to competition. Front-wing element(s) maximum width 63 inches total. Spill plates must be flat, vertical, and inner and outer surfaces must be parallel. Maximum thickness of spill plates including trailing edge of wicker 0.550-inch. Wicker permitted on trailing edge only.

NACA DUCTS

All NACA ducts regardless of where they are on the body of the dragster must be NHRA-accepted. Contact the NHRA Technical Department to determine whether they are permitted or prohibited.

ELECTRICAL: 8

ELECTRICAL COMPONENTS

Electrical and electronic components are restricted to ignition systems, data recorders, electrical gauges or indicators, automated fire extinguisher, fuel system, clutch control, and engine-shutoff system components only. The use of electrical/electronic timers to control pneumatic fuel-system valves, and/or electric fuel control solenoid valves, and/or clutch control valves is permitted. Functions of fuel timers, clutch timers, and ignition system must be initiated by wide-open throttle switch only.

IGNITION SWITCH

Each car in competition must have a positive on/off switch, capable of de-energizing the entire ignition system, in good working order, located within easy reach of the driver.

IGNITION SYSTEMS

The use of ignition systems and/or components is limited to those that have been NHRA-accepted for competition. The MSD 89712 Pro Mag Digital Retard Control and MSD 7570 Graphic Editor or MSD 8771 are the only accepted units for NHRA competition.

Any ignition system and/or components other than those specified must be NHRA-accepted prior to usage. Any other attachment prohibited. Ignition systems and/or components must be utilized in an unaltered manner consistent with the manufacturer's installation and instruction books unless otherwise approved. Maximum two spark plugs per cylinder. Spark plug tubes are mandatory and they must be made of stainless steel or aluminum. Removable or pin-type timing pointers prohibited.

ENGINE RPM CONTROLLER

Use of MSD 89712 or 8771 mandatory. Only latest approved firmware permitted.

MAGNETOS

Maximum two magnetos, limited to the following models: MSD Pro Mag Systems, 8130, 8140. All competitors must submit magnetos to the NHRA-accepted testing facility (MSD Ignition, Attn: Magneto Repair Department, 1350 Pullman Drive, Dock #14 El Paso, TX 79936). Please contact MSD Customer Service Department at 915-856-2785 to obtain an RMA number before

returning magnetos for certification. All magnetos must be certified and sealed by MSD Ignition prior to use in competition. Must maintain OEM pin-out orientation. See NHRARacer.com for pin-out definition.

SUPPORT GROUP: 9

COMPUTER/DATA RECORDERS

Data recorders permitted; must be NHRA-accepted. Accepted systems: Racepak Pro III, Pro II, Pro 1B, and Pro I. Data recorder may be used in conjunction with manufacturer's digital dash display. All Pro III output signals must be approved by NHRA Technical Department prior to use. Ride height sensors permitted; may only be connected to data recorder. See General Regulations 9:1, 9:2.

EVENT DATA RECORDER

Properly installed and operational PRC Systems Event Data Recorder (part number EDR1.0 or EDR 2.0) and PRC Systems Wire Assembly (part number WA1.0 or WA2.0) mandatory. The PRC Systems Event Data Recorder and Wire Assembly must be installed per the manufacturer's instructions. Modification of or tampering with the PRC Event Data Recorder and Wire Assembly prohibited.

FIRE EXTINGUISHER SYSTEM

Fire extinguisher system meeting SFI Spec 17.1 mandatory on cars with an enclosed cockpit. Minimum 5-pound, NHRA-accepted fire extinguisher system. Must be installed per manufacturer's specifications with all gauges clearly visible. See General Regulations 9:3 for NHRA-accepted fire extinguishing agents.

SHUTOFF DEVICE

Properly installed and operational Electrimotion Funny Car Safety Shutoff Controller Kit (part number SB001FC, SB002FC, or CM3.0) and Electrimotion Shutoff Receiver (part number RF001) mandatory. The Electrimotion Funny Car Safety Shutoff Controller Kit must be installed per the manufacturer's instructions. Modification of or tampering with the Electrimotion Funny Car Safety Shutoff Controller Kit prohibited. The activation of the system override switch by any means other than parachute deployment is prohibited. The Electrimotion Crew Alert Box, part number CB001 and the Motorsports Safety Electronics Shutoff System part number MS1150, may be used in conjunction with the Shutoff Device to illuminate a dash light for driver notification, disengage throttle and/or enable the shutoff device. Any other use of the Electrimotion Crew Chief Alert box or the Motorsports Safety Electronics Shutoff System is prohibited.

TOW VEHICLES

No full-size vehicles allowed in starting-line area; a starting cart mandatory. The maximum starting-cart size can equal that of a standard golf cart without a canopy. Full-size chase vehicles permitted. See General Regulations 9:12.

WARM-UPS

When starting a vehicle in the pit area, vehicle must be fully within the assigned space. No part of the rear tire may extend past the end of trailer. When occupying an "end spot" pit space, or if the neighboring trailer does not completely shield your vehicle, it is mandatory to park a tow truck/car alongside the vehicle while engine is running. Vehicle must have a pedal stop that limits the throttle opening to a maximum of 3/4 of wide-open-throttle. Pneumatic throttle devices prohibited. Jackstand devices must provide a minimum ground clearance of 7 inches. See General Regulations 9:5, 9:14.

DRIVER: 10**ARM RESTRAINTS**

Mandatory. See General Regulations 10:3.

CREDENTIALS

Valid NHRA competition license mandatory. See General Regulations 10:4.

DRIVER RESTRAINT SYSTEM

Minimum 7-point driver restraint system meeting SFI Spec 16.1 or 16.5 mandatory. All shoulder, lap, and leg straps may be wrapped around a frame or chassis tube, provided the belt is properly aligned toward the direction of pull. When fastened with driver in position, absolutely no "folds" are permitted in any belt(s). Otherwise, all belts must be mounted to the chassis via mounting brackets that are bolted or welded to the chassis per the manufacturer's instructions. If bracket is bolted through framerail or chassis tube, hole in framerail or chassis tube must be bushed, with bushing completely welded to tube. Whether mounted directly to frame or to a tab welded to the frame, mounting bracket attachment bolt must be in double shear and of shoulder bolt design, so as to permit the bracket to pivot and align toward the direction of pull. Shoulder belts must utilize two individual straps, each with its own mount and mounting point. All belts must be covered with a fire-resistant covering. Restraint system must be updated at two-year intervals from date of manufacture. See General Regulations 10:5.

HEAD AND NECK RESTRAINT DEVICE/SYSTEM

At all times that the driver is in the race vehicle, from the ready line until the vehicle is on the return road, driver must properly utilize an SFI-approved head and neck restraint device/system, including connecting the helmet as required for full functionality of the device. The device/system must meet SFI Spec 38.1 and must display a valid SFI label. The head and neck restraint device/system, when connected, must conform to the manufacturer's mounting instructions, and it must be configured, maintained, and used in accordance with the manufacturer's instructions.

HELMET

Full-face helmet meeting Snell SA2010, or SA2015, FIA 8860-2010, 8860-2015 or 8860-2018 with shield mandatory. Eject Helmet Removal System (part number SDR 890-01-30) mandatory and must be installed per manufacturer instructions. A Stand 21 Lid Lifter head sock meeting SFI 3.3 may be used in lieu of the Eject Helmet Removal System. See General Regulations 10:7.

PROTECTIVE CLOTHING

Driver's suit meeting SFI Spec 3.2A/20, long sleeve underwear shirt meeting SFI 3.3., long underwear pants meeting SFI 3.3, SFI Spec 3.3/20 gloves, glove under-liners made of flame retardant material, SFI Spec 3.3/15 boots/shoes, socks meeting SFI 3.3, SFI Spec 3.3 head sock, and SFI Spec 3.3/10 helmet skirt mandatory. All jacket/pants or suits meeting SFI Spec 3.2A/20 must be recertified on a five-year interval. All clothing containing metal or plastic prohibited. Undergarments that are worn in addition to those mandated that are made of flammable materials (e.g. nylon, rayon, polyester, spandex etc.) are prohibited. All jewelry prohibited. A 3000 PSI, 112 cubic inches minimum capacity fresh air breathing system mandatory. System must be manufactured and installed by the original helmet manufacturer or with written authorization of the original helmet manufacturer. Helmet must meet applicable SFI and/or Snell specs with fresh air system installed. Compressed air only. Air must be supplied by constant pressure. See General Regulations 10:10.

SECTION 20 EXHIBITION VEHICLES

The NHRA exhibition-vehicle program encompasses the following vehicles: jet-powered dragsters and Funny Cars, wheelstanders, jet trucks, fuel motorcycles, V-8-powered motorcycles, diesel trucks, special fuel, and nitro Harley-Davidson. All rules from the NHRA Rulebook apply to these vehicles. Additionally, an Exhibition Vehicle Rulebook Supplement is available on NHRARacer.com or from the NHRA Technical Services Department for each of these categories.

Anyone considering construction of a vehicle for one of these categories must submit renderings and designs to the NHRA Technical Services Department. Concepts will be analyzed on an individual basis by the NHRA Exhibition Committee and criteria will be established for concepts gaining NHRA acceptance.

As not all concepts are accepted, proposals and inquiries should be forwarded to the NHRA Technical Services Department before beginning construction.

GENERAL REGULATIONS INDEX

ENGINE: 1

1:1	Cooling System	3
1:2	Engine	3
1:3	Exhaust	3
1:4	Flash Shields	4
1:5	Fuel Systems	4
1:6	Fuel	5
1:7	Liquid Overflow	8
1:8	Lower Engine Containment Device	8
1:9	Oil System	9
1:10	Supercharger	9
1:11	Supercharger Restraint Device	10
1:12	Throttle	10
1:13	Vent Tubes, Breathers	10

DRIVETRAIN: 2

2:1	Anti-Blowback Device	10
2:2	Axle-Retention Devices	10
2:3	Clutch	10
2:4	Driveline	11
2:5	Flywheel	12
2:6	Flywheel Shield & Motor Plate: General	12
2:7	Flywheel Shield: Top Fuel and Funny Car	13
2:8	Flywheel Shield: Top Alcohol Dragster and Top Alcohol Funny Car	14
2:9	Flywheel Shield: Pro Stock and Comp	14
2:10	Flywheel Shield: Other Classes	15
2:11	Rear End	15
2:12	Transmission	16
2:13	Transmission, Aftermarket Planetary	16
2:14	Transmission, Automatic/NHRA-Accepted	16

BRAKES & SUSPENSION: 3

3:1	Brakes	16
3:2	Shock Absorbers	17
3:3	Steering	17
3:4	Suspension	17
3:5	Traction Bar Rod Ends	17
3:6	Wheelie Bars	18

FRAME: 4

4:1	Alignment	18
4:2	Ballast	18
4:3	Deflector Plate	18
4:4	Frames	19
4:5	Ground Clearance	19
4:6	Magnaflux Certificates	19
4:7	Mounting Hardware	19
4:8	Parachutes	20
4:9	Pinion Support	20
4:10	Roll Bar	20
4:11	Roll Cage	21
4:12	Wheelbase	30

TIRES & WHEELS: 5

5:1	Tires	30
5:2	Wheels	30

INTERIOR: 6

6:1	Driver Compartment31
6:2	Upholstery, Seats31
6:3	Window Net32

BODY: 7

7:1	Air Foils, Wings32
7:2	Competition Numbers.33
7:3	Fenders.33
7:4	Firewall33
7:5	Floor33
7:6	Hood Scoop34
7:7	Windscreen.34
7:8	Windshield, Windows34

ELECTRICAL/CONTROL: 8

8:1	Batteries35
8:2	Delay Boxes/Devices35
8:3	Ignition36
8:4	Master Cutoff37
8:5	Starters37
8:6	Taillights37
8:7	Switches & Buttons37
8:8	Shift Light37

SUPPORT GROUP: 9

9:1	Computer37
9:2	Data Recorders.38
9:3	Fire Extinguisher38
9:4	Generators39
9:5	Jacks & Jackstands39
9:6	Lifting Devices39
9:7	Oversize Trailers39
9:8	Pressurized Bottles.39
9:9	Push Bars40
9:10	Telemetry Devices.40
9:11	Traction Control40
9:12	Tow Vehicle40
9:13	Two-Way Radio Communication40
9:14	Warm-Ups.40
9:15	Cameras41

DRIVER: 10

10:1	Apparel41
10:2	Appearance.41
10:3	Arm Restraints41
10:4	Credentials41
10:5	Driver Restraint Systems43
10:6	Head Protector44
10:7	Helmet44
10:8	Neck Collar/Head and Neck Restraint Device/System45
10:9	Occupants45
10:10	Protective Clothing46
10:11	Seat Belts46

GENERAL: 11

11:1	Advertising and Other Material/Displays	47
------	---	----

SECTION 21

GENERAL REGULATIONS

Throughout this Rulebook, a number of references are made for particular products to meet certain specifications (i.e., SFI Specs, Snell, DOT, etc.). It is important to realize that these products are manufactured to meet certain specifications, and upon completion, the manufacturer labels the product as meeting that spec. Therefore, except as outlined under SFI requirements, any change to the product voids that certification.

Under no circumstances may any certified product be modified, altered, or in any way vary from the “as manufactured” condition. Such a practice is in violation of the SFI, Snell, DOT, etc. program, voids such certification and therefore will not be accepted by NHRA.

Notice: It is the responsibility of the participant, not NHRA or any track, to ensure that all safety equipment is not modified or altered, is approved and is correctly installed, worn, maintained and used.

ENGINE: 1

1:1 COOLING SYSTEM

All cooling systems/radiators must be installed in the stock location for body style used. Front-engine dragsters must have system installed in front of engine. Rear-engine dragsters with radiator mounted in front of engine must install a deflector from framerail to framerail and to the top of the roll cage. Portion above shoulder hoop may be width of roll cage bars, unless radiator extends above top of shoulder hoop. If radiator extends above shoulder hoop, then deflector plate must maintain width of radiator. See 4:3 DEFLECTOR PLATE.

1:2 ENGINE

Classes limited to automotive engines only unless otherwise stated under Class Requirements. Contestants in weight-to-cubic-inch classes must claim cubic-inch displacement of engine used; under no circumstances may claimed displacement exceed actual displacement by more than 5 cubic inches. No allowance for overbore; any part of a cubic inch is rounded off to the next highest inch (i.e., 301.2 = 302). If engine size is changed during a race, competitor must report to Technical Department supervisor before a run is attempted. Crankshaft centerline must not exceed 24 inches from ground in any class, except trucks. Maximum height 36 inches for trucks running 12.00 and slower; 31 inches for trucks running 11.99 to 10.00; and 24 inches for trucks running 9.99 seconds and quicker. Engine must be mounted to frame by a minimum of two 3/8-inch-diameter Grade 5 bolts. Valvetrain must incorporate conventional automotive coil spring design; pneumatic-type valvetrains are prohibited in all classes. All classes, with the exception of Stock and E.T. cars slower than 10.99 seconds, harmonic balancer meeting SFI Spec 18.1 or solid metallic hub mandatory. All cars with pressed-on front harmonic balancers must have such installed to protect accidental loss (i.e., drilled and bolted). Ceramic bearings prohibited in all NHRA categories.

1:3 EXHAUST

All vehicles must be equipped with exhaust collectors, headers, or stacks installed to direct exhaust out of vehicle body to rear of car, away from driver and fuel tank. No part of the exhaust system

may be routed through the driver's compartment. Exhaust system components must be securely fastened (i.e., metal connector straps, bolted, welded, etc.) to prevent loss of system components during competition. All removable multipiece exhaust collectors/stacks must be securely fastened with either an NHRA-accepted header tether, a minimum 1/2" (half-inch) stitch weld located on each primary tube, or be permanently attached to the vehicle body or frame with positive fasteners (i.e., exhaust hangers, support brackets, bolts/nuts, etc.) such that they require tools for removal. A current list of NHRA-accepted header tethers is available on NHRARacer.com. Flexible tubing or "flex pipe" prohibited in all categories. If mufflers are used, they must be securely attached to exhaust system and vehicle body or frame. Consistent with its endeavors to maintain drag racing's acceptance as a recognized sport and recreation, NHRA is enforcing maximum decibel levels for Super Street, Super Gas, and Super Comp vehicles competing at national events. NHRA may enforce the same or similar requirements on other categories in the future.

Part of NHRA's mission is to preserve the right to race. In many communities, the right to race is contingent upon reducing noise and complying with local noise and muffler laws, ordinances, regulations, or agreements. Therefore, all competitors must comply with any muffler rules applicable to his or her class in the Rulebook, and must comply with any noise-reduction requirements (including mufflers) mandated by any member track at which he or she races. Member tracks have the authority to impose muffler rules and noise regulations beyond those required by the NHRA Rulebook.

1:4 FLASH SHIELDS

Carburetor inlet must not be openly exposed. In lieu of hood, carburetors must be equipped with a flash shield or velocity stacks that cover the top, back, and sides, preventing fuel from being siphoned into the airstream or blown into driver's face. Additionally, any car that is driven, not towed, through the pits, with open stack(s) not protected by hood or scoop, must have screening installed on open stack(s) to prevent items from entering stack.

1:5 FUEL SYSTEMS

Location: All fuel tanks, lines, pumps, valves, etc. must be outside of the driver's compartment and within the confines of the frame and/or steel body. Cool cans, fuel-distribution blocks, etc. must be located at least 6 inches forward of the flywheel/bellhousing area on rear-wheel-drive (RWD) vehicles, and on opposite side of flywheel/housing area on front-wheel-drive (FWD) vehicles. Fuel pressure gauge isolators, with steel braided line, may be mounted on firewall.

Tanks: When permitted by class regulations, fuel tanks located outside body and/or frame must be enclosed in a steel tube frame constructed of minimum 1 1/4-inch O.D. x .058 chromoly or .118 mild steel tubing. All fuel tanks must be isolated from the driver's compartment by a firewall, completely sealed to prevent any fuel from entering the driver's compartment. All fuel tanks must have a pressure cap and be vented outside of body. A positive-locking screw-on fuel tank cap is mandatory on all open-bodied cars. Insulated fuel tanks prohibited. When used, nonmetallic fuel cells must have a metal box protecting the part of the fuel cell that is outside of body lines or trunk floor, excluding hose connection area in rear. The metal box must be constructed of minimum .024 steel or .032 aluminum. Nonmetallic fuel cells or tanks must be grounded to frame.

Lines: All non-OEM fuel lines (including gauge and/or data

recorder lines) must be metallic, steel braided, or NHRA-accepted “woven or woven-pushlock.” A maximum of 12 inches total (front to rear) of non-metallic or non-steel braided hose is permitted for connection purposes only; individual injector nozzle and motorcycle fuel lines are excluded. Fuel lines (except steel braided lines) in the flywheel/bellhousing area must be enclosed in a 16-inch length of steel tubing, 1/8-inch-minimum wall thickness, securely mounted as a protection against fuel-line rupture. Fuel lines may not be routed in the driveshaft tunnel. It is mandatory that fuel lines passing supercharger drive belts be steel braided, NHRA-accepted woven or woven-pushlock, or be enclosed in protective steel tubing. A current list of NHRA-accepted woven or woven-pushlock fuel lines is available on NHRARacer.com. All NHRA-accepted fuel lines must use ends that are specifically designed for the type of fuel line being used. No hose clamps allowed on NHRA-accepted fuel lines.

Pumps/Valves: Cars equipped with carburetor(s) or non-electronic fuel (EFI) systems but with mechanical non-OEM fuel pumps must have a quick-action fuel-shutoff valve within easy reach of driver and located in the main fuel line between the fuel tank and the carburetor and/or injectors. Fuel recirculation systems not part of normal fuel/pump system prohibited. All cars in Stock, Super Stock, Competition, and Pro Stock must be equipped with a positive-lock drain valve located between the fuel tank and the carburetor(s) or fuel injector to facilitate removal of fuel samples for fuel-check purposes.

Fuel/Air: Any method of artificially cooling or heating fuel prohibited (i.e., cool cans, Freon, wet rags, etc.), except as noted in Class Requirements. Cool cans, wet towels, etc. are permitted in Super Stock, Stock, Super Comp, Super Gas, Super Street, and E.T. classes. Wet towels, rags, ice, etc. must be removed before vehicle leaves staging area. Coolers, chillers, etc., where permitted by class requirements, are prohibited outside of the competitor’s pit. Ambient-temperature air only; cooling or otherwise changing the conditions of the intake air is prohibited. Spraying of intake with any artificial spray or coolant prohibited.

Alternative Fuels: Containers for alternative fuels must be permanently labeled by the manufacturer as suitable for CNG or propane. Tank must be vented outside of body. Alternative fuel systems must incorporate pressure-relief valve meeting standards listed in NFPA 52. Alternative fuel systems must incorporate a manual shutoff valve according to standards listed in NFPA 52 for CNG vehicular systems. All hoses/lines used for alternative fuels must be permanently and distinctively marked by the manufacturer as to manufacturer name or trademark, service identifier, and design pressure. Plastic, cast iron, galvanized, copper, or aluminum pipe or hoses prohibited.

1:6 FUEL

Racing Gasoline: A current list of NHRA-accepted racing gasoline is available on NHRARacer.com. For all categories using racing gasoline except Stock and Super Stock, racing gasoline is defined for purposes of this Rulebook as a mixture of hydrocarbons only. For Stock and Super Stock categories, racing gasoline is defined for purposes of this Rulebook as a mixture of aromatic and/or cyclic and/or paraffinic hydrocarbons. Non-cyclic olefinic hydrocarbons and non-hydrocarbons that do not increase the specific energy of the gasoline are allowed to the extent they do not exceed 1 percent (1%) by volume and are blended in the gasoline by the refiner or fuel manufacturer. Non-hydrocarbons that do not increase the specific energy of the gasoline are allowed to the extent that

they do not exceed 0.15 percent by volume and are blended in the gasoline by the refiner or fuel manufacturer. Racing gasoline is a good electrical insulator, or dielectric, and its relative effectiveness as an insulator is represented by its Dielectric Constant. The average D.C. for the hydrocarbons that make up gasoline is 2.025. This is defined as a reading of "0" with the NHRA Fuel Check meter. Racing gasoline is tested and certified at NHRA events by the application of various chemical analyses as considered appropriate by Fuel Check personnel. Racing gasoline in a vehicle may be checked before use in competition.

Methanol: Methanol is a clear, colorless liquid with a mild odor at ambient temperatures. Methanol is sold in two U.S. Federal Grades: A and AA. Either grade is permitted for use in NHRA competition, and racers should ensure that the methanol they purchase meets federal standards of purity. The purity standards for each grade are shown in the table below.

SPECIFICATIONS FOR PURE METHANOL

Property	Grade A	Grade AA
Methanol content, wt percentage, min	99.85	99.85
Acetone and aldehydes, ppm, max	30	30
Acetone, ppm, max	20	
Ethanol, ppm, max	10	
Acid (as acetic acid), ppm, max	30	30
Water content, ppm, max	1500	1000
Specific gravity, 20C	.7928	.7928
Permanganate time, min	30	30
Odor	Characteristic	
Distillation range at 101 kPa (760mm Hg)	Not more than 1°C, including 64.6 +/- 0.1°C at 760mmHg	
Color, platinum-cobalt scale, mix	5	5
Appearance	clear-colorless	
Residual on evaporation, g/100 mL	.001	.001
Carbonizable impurities; color platinum-cobalt scale, max	30	30

Methanol is tested and certified at NHRA events by the application of various chemical analyses as considered appropriate by Fuel Check personnel. To be considered legal, methanol used in NHRA competition must meet the federal standards of purity. Any deviation from these standards because of impurities (beyond the limits established in the federal specification) in the fuel sample will result in disqualification. Because methanol is a hygroscopic substance, it readily absorbs moisture from the air, which rapidly renders methanol illegal as a fuel for use in NHRA competition. Racers are cautioned to keep methanol containers tightly capped at all times to minimize the absorption of water. Racers are encouraged to have Fuel Check personnel check samples of their methanol any time there may be doubt as to its purity.

Nitromethane: Only nitromethane from an NHRA-accepted on-site supplier may be present on-site or used on-site at any NHRA Mello Yello Drag Racing Series event ("NHRA National Event") or NHRA Lucas Oil Drag Racing Series event ("NHRA Divisional Event"). To be eligible for competition, any team using nitromethane must use nitromethane from an accepted on-site supplier. At this time, the only accepted on-site supplier is Sunoco Racing Fuels. Fuel anywhere on-site at an NHRA National Event or NHRA Divisional Event, including without limitation, in the vehicle, transporter, pit area, or at the NHRA-accepted supplier's on-site location, may be checked at any time and for any reason, including compliance with this rule

and with the Nitromethane specification. Any participant who violates any rule regarding nitromethane may be banned from competition at the applicable event, and shall be subject to such other penalty deemed appropriate by NHRA.

Specifications for Nitromethane as Used as a Fuel in the NHRA Mello Yello Drag Racing Series and in the Lucas Oil Drag Racing Series:

Property	Minimum	Maximum
Nitromethane	99.5%	Not applicable
Water	Not applicable	0.5%
Specific Gravity @ 60° F	1.140	1.145
Acidity as Acetic Acid	Not applicable	0.20%
Amines	Not applicable	Not allowed
Heavy Metals (Pb, Hg)	Not applicable	Not allowed
Alcohols and products consistent with the manufacturing process	Balance	Balance
Color (light yellow) clear nitromethane not allowed	Not applicable	Not applicable
Odor (typical)	Not applicable	Not applicable
Methyl tert-butyl ether	Not applicable	0.1%
Dimethyl Sulfate	Not applicable	15 ppm

Molecular Weight	61.04
Boiling Point	101°C (214°F)
Critical Temperature	315°C (599°F)
Critical Pressure	62atm, 915psia, 6282kPa
Vapor Pressure	
@ 20°C/68°F	27.3 mm Hg (3.6 kPa)
@ 40°C/104°F	74.8 mm Hg (9.9 kPa)
@ 60°C/140°F	177.8 mm Hg (23.7 kPa)
Density	
@0°C/32°F	1.162 g/ml
@20°C/68°F	1.138 g/ml
@30°C/86°F	1.124 g/ml
@50°C/122°F	1.098 g/ml
Approximate Coefficient of Expansion 1/°C (1/°F)	0.00122 (0.00068)
Solubility H2O in NM@70°C (158°F)	19.3% by weight

NITROMETHANE REGULATIONS

The Department of Homeland Security (DHS) under the Chemical Facility Anti-Terrorism Standards (CFATS) has

identified nitromethane as a chemical of interest (COI). The law requires anyone who possesses 400 pounds (42 gallons) or more of nitromethane to complete and submit a "Top Screen" questionnaire to the Department of Homeland Security. NHRA has stressed for many years the importance of being not only responsible, but leaders, in the area of nitromethane security. The use of nitromethane in the sport of NHRA Drag Racing is vital to our sport and we need to take necessary measures to ensure its use for the foreseeable future.

Failure to comply can lead to civil penalties, fines up to \$25,000 per day or having the racing activity shut down. For additional information and instruction, we encourage you to contact the Department of Homeland Security at 1-866-323-2957 or csat@hg.dhs.gov. Additional information is also available at visit <https://www.dhs.gov/critical-infrastructure-chemical-security>. NHRA cannot stress enough the importance of everyone in the racing community continuing to be conscious of the issues around nitromethane.

CHEMISTRY

Note: All nitromethane is required to contain an active safety indicator that changes color when the nitromethane has been sensitized or contaminated.

Typical Physical Properties

Nitrous Oxide: Nitrous oxide permitted in E.T. classes, Top Sportsman, Top Dragster, Pro Mod, and A/PM only. Push system permitted. All bottles must be securely mounted (may not use plastic brackets), stamped with minimum DOT-1800 pound rating, and identified as nitrous oxide. All bottles that are 5 pounds or greater in weight must be mounted inside of the vehicle's framerails or within the confines of the roll cage. Nitrous oxide bottle(s) located in driver compartment must be equipped with a relief valve and vented outside of compartment. System must be commercially available and installed per manufacturer's recommendations. Commercially available, thermostatically controlled blanket-type warmer accepted. Any other external heating of bottle(s) prohibited.

Propylene Oxide: The use of propylene oxide is prohibited in all categories.

1:7 LIQUID OVERFLOW

All cars in competition with any type of water overflow capable of spilling water must have a catch can to accumulate the excess liquids and prevent leaking onto the track. Minimum catch can capacity: 1 pint. Catch can must be securely fastened; i.e., bolted, clamped. Overflow may be routed into headers on cars that are supercharged or burn nitromethane or alcohol.

1:8 LOWER ENGINE CONTAINMENT DEVICE

In classes where specified, must utilize an NHRA-accepted lower engine oil-retention device. SFI Spec 7.1 or 7.2 Lower Engine Containment Device permitted. A properly fitting lower engine ballistic/restraint device mandatory. The NHRA Technical staff can accept or reject any device. Any device that fails to perform as required must be replaced or repaired to the satisfaction of the Technical staff prior to any further runs. When used, an SFI Spec 7.1 or 7.2 Lower Engine Containment Device must cover the sides of the block and pan up to within one inch of the head mating surface and extend to within 1 1/2 inches of the front and rear of the cylinder case area. SFI Spec 7.1 devices must be updated/recertified by the original manufacturer at one-year intervals. In classes where specified, a belly pan may be used in lieu of a device attached to the engine. The belly pan must extend from framerail to framerail and extend forward of the harmonic

balancer and to the rear of the engine block and must incorporate a minimum 2-inch-high lip on all sides unless specified in Class Requirements. Minimum number of slots or holes in the walls to clear frame, steering, or lines permitted. A nonflammable, oil-absorbent liner mandatory inside of retention device.

1:9 OIL SYSTEM

Accu-sump, dry-sump tanks, oil filters, oil supply lines, etc. prohibited in driver compartment and outside of frame and/or steel body/fenders, except as noted in Top Fuel. Oil-pressure gauge and line permitted in driver compartment, metal or steel braided line mandatory, maximum 3/16-inch inside diameter. Power-enhancing additives prohibited.

1:10 SUPERCHARGER

Roots-type: Maximum size: 14-71, 22 1/4-inch case length, 11 1/4-inch case width, 19-inch rotor length; maximum rotor diameter: 5.840 inches including fixed stripping. The case must be one piece with removable front and rear bearing end plates; rotor must be contained within one-piece case. For Top Fuel and Funny Car, inlet/outlet cavity restricted to maximum 1 inch, measuring from face of bearing plate to the back of the cavity. For Top Fuel and Funny Car specifications, see Class Requirements. Rotor helix angle may not exceed that of a standard 71-series GM-type rotor (4 degrees per inch). Maximum overdrive may not exceed 1.70. For Top Fuel and Funny Car, overdrive may not exceed 1.50 except in Denver, where 1.70 is the maximum. Aluminum studs (supercharger to manifold) mandatory in Advanced E.T., Comp, Top Alcohol Dragster, Top Alcohol Funny Car, Funny Car, and Top Fuel. See Class Requirements for manifold burst panel and restraint specifications.

Roots-type high helix: Must adhere to same maximum case dimensions and maximum rotor cavity diameter as standard Roots. Rotor helix angle may not exceed 6.5 degrees per inch (123.5 degrees total over 19-inch maximum rotor length). Use of high-helix supercharger is restricted to Advanced E.T., Competition (Pro Mod only), Top Alcohol Dragster, and Top Alcohol Funny Car. Maximum overdrive may not exceed 1.70 percent. Aluminum studs (supercharger to manifold) mandatory. See Class Requirements for manifold burst panel and restraint specifications.

Screw-type: Must meet SFI Spec 34.1. Maximum case length 16 inches; maximum case width 16 inches; minimum case and front-plate thickness 1/4-inch; minimum rear-plate thickness .300-inch. Overdrive limits for Top Alcohol Dragster are found in Section 11, Top Alcohol Funny Car is found in Section 12. Under no circumstances may a screw supercharger overdrive exceed the following overdrive limits:

Engine Displacement	PSI Maximum Overdrive
500 cubic inches or larger	2.25
450 to 499 cubic inches	2.15
less than 450 cubic inches	2.04

Manifold burst panel meeting SFI Spec 23.1 (in addition to supercharger panel) and restraint device meeting SFI Spec 14.21 mandatory. PSI screw supercharger permitted to use a tandem burst panel kit, installed per PSI instructions on superchargers only. Any other use of double burst panels on any supercharger or manifold prohibited. Aluminum studs (supercharger to manifold) mandatory. Overdrive limits, as determined appropriate by NHRA, are subject to adjustment at any time as dictated by performance. Variable multi-speed supercharger devices prohibited regardless of supercharger type. Any changes to any screw supercharger design, materials, construction, etc. after Jan. 1, 1997, are subject to NHRA acceptance before being permitted to run.

ALL SUPERCHARGERS: For all Top Alcohol Funny Car, Top Alcohol Dragster, Comp, Super Comp, and Advanced E.T. cars, and E.T. cars running 9.99 seconds or quicker, fuel and/or oil lines must be shielded wherever they pass the supercharger drive belt. Either a belt guard or fuel/oil line guard may be used.

1:11 SUPERCHARGER RESTRAINT DEVICE

Supercharger restraint system meeting SFI Specs mandatory per Class Requirements. Restraint system must be updated at two-year intervals from date of manufacture. The blower restraint straps and fuel lines must be installed such that when the restraint straps are fully extended no load is placed on any of the fuel lines. See Class Requirements.

1:12 THROTTLE

Regardless of class, each car must have a foot throttle incorporating a positive-acting return spring attached directly to the carburetor/injector throttle arm. A positive stop or override prevention must be used to keep linkage from passing over center and sticking in an open position. In addition to return springs, some means of manually returning the throttle to a closed position by use of the foot must be installed on all altered linkage systems except hydraulically or cable-operated systems. Per Class Requirements throttle control must be manually operated by driver's foot; electronics, pneumatics, hydraulics, or any other device may in no way affect the initial throttle operation. In Super Street, Super Gas, Super Comp, and certain E.T. bracket classes, timed throttle stops are permitted that use pneumatics and or electronics to modulate the throttle after initial launch. Cable throttle systems permitted. NHRA-accepted hand controls for the physically challenged permitted. Choke cables and brazed or welded fittings on steel cable prohibited. No part of throttle linkage may extend below framerails.

1:13 VENT TUBES, BREATHERS

Mandatory as outlined in Class Requirements; permitted on all cars. Where used, the tubes must terminate into an acceptable, permanently attached catch tank with a minimum capacity of one gallon per engine (except as noted in Class Requirements). The catch tank must be baffled to keep overflow off track. Breather/vent tubes must be mechanically secured (tie-wraps prohibited) to the fittings and the fittings locked at both ends.

DRIVETRAIN: 2

2:1 ANTI-BLOWBACK DEVICE

If mandated by class requirements, a brace or device must be installed that will prevent the bellhousing or adapter shield from being blown rearward in the event of flywheel and/or clutch explosion. Material required is 4130 chromoly, minimum size is .875-inch O.D. x .083-inch wall tubing with 3/8-inch fasteners. Ball-lock pins prohibited.

2:2 AXLE-RETENTION DEVICES

All cars, except Stock and some E.T. cars as noted in Class Requirements, must be equipped with a satisfactory means of rear-axle retention; minimum .120-inch aluminum or .090-inch steel bearing retainer mandatory. Stock "C"-clip axle retention prohibited as outlined in Class Requirements.

2:3 CLUTCH

Each car in competition, except those with automatic transmissions, must be equipped with a foot-operated clutch incorporating a positive stop to prevent clutch from going over center or past neutral, as in the case of centrifugal units. All pedals must be covered with non-skid material. NHRA-accepted hand controls for the physically challenged permitted. All slider

clutches must meet SFI Spec 1.2, 1.3, or 1.4 as outlined under Class Requirements. In Class Requirements that call for an SFI Spec 1.2 clutch, an SFI Spec 1.5 clutch can be used. Multi-disc clutch assembly for non-OEM supercharged, nitrous-oxide injected, and non-OEM turbocharged vehicles must meet SFI Spec 1.3, 1.4, or 1.5 and must utilize an SFI Spec 6.2 or 6.3 flywheel shield, except as noted in Class Requirements.

2:4 DRIVELINE

For cars with driveshafts that contain universal joints:

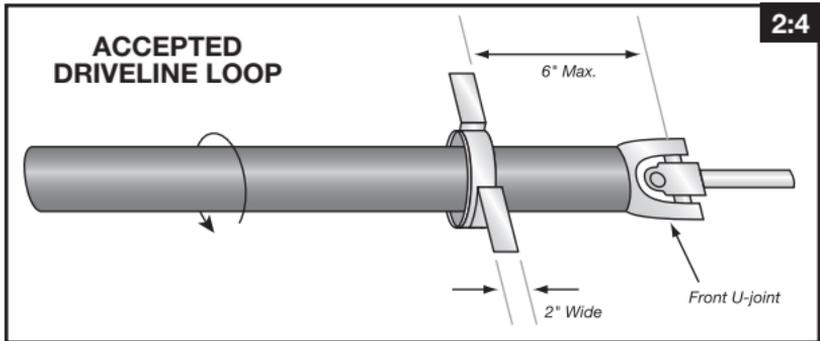

For all full-bodied and open-bodied cars running between 7.50 (*4.50) and 13.99 (*8.59) in place of a crossmember located behind but within 6 inches of the center of the front universal joint: A front driveshaft loop is required on all cars, except vehicles running 11.49 (*7.35) seconds or slower equipped with street tires. See Class Requirements.

Full-bodied cars 7.49 (*4.49) seconds and quicker with the OEM floor retained (i.e., OEM floor may be modified according to Class Requirements for transmission removal but must be intact from 6 inches behind the center of the front universal joint rearward): A front driveshaft loop is required. See Class Requirements.

Full-bodied cars 7.49 (*4.49) seconds and quicker with the OEM floor removed/replaced: Each end of the driveshaft must have a round 360-degree driveshaft loop within 6 inches of the U-joint, and a driveshaft tube is also required. See Class Requirements.

Open-bodied cars 7.49 (*4.49) seconds and quicker where the driveshaft passes any part of the driver's body: Each end of driveshaft must have a round 360-degree driveshaft loop within 6 inches of U-joint, and a driveshaft tube is also required. The driveshaft tube must extend the full length of the portion of the driveshaft that passes any portion of the driver's body or extend to within 6 inches of the centerline of the rear U-joint. For center steer cars with the driver seated above the driveshaft in lieu of a driveshaft tube a plate above the driveshaft of minimum thickness .120-inch steel or titanium with a minimum of four attachment points to the chassis, using either minimum 5/16 SAE Grade 8 bolts, welded, or 1/4-inch push/pull pins may be used. The plate must be at least as wide as the seat. See Class Requirements.

For all cars with driveshafts that do not contain universal joints but pass any part of the driver's body: Each end of driveshaft must have a full 360-degree cover of minimum 1/16-inch steel or 1/8-inch aluminum. Rear cover must surround the coupler. Front cover must surround the driveshaft from the back of the reverser to the end of the splicer sleeve in the area of the driver's legs. All covers must be securely mounted to frame, suitable crossmember, reverser, or third member. See Class Requirements.

DRIVESHAFT LOOP DEFINITION: 360 degrees of enclosure,

1/4-inch minimum thickness and 2 inches wide, or 7/8-inch x .065-inch welded steel tubing, securely mounted to the frame or frame structure where available (or to the OEM floor or rocker box where a frame does not exist) and located within 6 inches of the front or rear universal joint for support of the driveshaft in event of U-joint failure.

DRIVESHAFT TUBE DEFINITION: Driveshaft must be covered by a 360-degree round, oval, or tapered tube, covering the front U-joint and extending rearward a minimum 12 inches. Minimum thickness of tube is .050-inch steel or titanium. Driveshaft tube must utilize a minimum of four attachment points to the chassis, using either minimum 5/16 SAE Grade 8 bolts, welded, or 1/4-inch push/pull pins. Two-piece tube assembly permitted with a minimum of six 3/8-inch SAE Grade 8 bolts.

2:5 FLYWHEEL

The use of stock-type cast iron flywheels and/or pressure plates prohibited. The use of aluminum flywheels in Top Fuel and Funny Car is prohibited. Units meeting SFI Spec 1.1, 1.2, 1.3, 1.4, or 1.5 mandatory except as noted in Class Requirements.

2:6 FLYWHEEL SHIELD & MOTOR PLATE: GENERAL

The use of aluminum bellhousing is permitted in all categories and applications. The aluminum bellhousing must meet applicable SFI Specifications. Absolutely no modifications to as-manufactured design are permitted on SFI Spec 6.1, 6.2, or 6.3 flywheel shields and/or liners. An SFI Spec 6.1W bellhousing is also acceptable wherever an SFI Spec 6.1 bellhousing is mandatory or permitted. All 6.2 and 6.3 titanium bell housings must be reinspected and recertified yearly. SFI 6.1 titanium and aluminum bell housings and SFI 6.2 or 6.3 steel bell housings must be reinspected and recertified every two years (or as specified by the manufacturer). SFI 6.1 bell housings must be reinspected and recertified every five years (6.1). Where SFI Spec bell housings are mandatory, all applicable liners, large mounting fasteners, motor plates, etc., as required by SFI Specs or the manufacturer, must be properly installed. **For all new flywheel shields and for all flywheel shields certified or recertified after Nov. 14, 2012, all liners must be flush with the motor plate; liners may be notched for starter gears/snouts.**

Where an SFI 6.1 or 6.3 bellhousing is mandatory, a full, one-piece motor plate is also mandatory at the rear of the engine block. The motor plate must be constructed of steel or 6061-T6, 7075-T6 or 2024-T3 wrought heat-treated aluminum alloy plate, minimum 1/8-inch thick for 6.1 applications, minimum 3/16-inch thick for 6.3 applications. In addition to the fastener requirements noted below, the SFI 6.3 flywheel shield must be fastened to the motor plate with four 1/2-inch-diameter Grade 5 shoulder bolts or high strength steel (or titanium) fasteners and nuts, one in each quadrant. Where an SFI 6.2 bellhousing is mandatory, see Section 2:8 for motor plate and fastener requirements.

The flywheel shield must be fastened to the engine and motor plate with a full complement (all available engine bolt holes or as specified by the manufacturer) of Grade 8 bolts or high strength studs. The use of Allen bolts to fasten the shield to engine or motor plate, to fasten covers, etc. is prohibited. All bolts (not studs or nuts) used for flywheel shield mounting, covers, etc. must be identifiable as to grade; all nuts and bolts associated with flywheel shield mounting, covers, etc. must be full standard depth, width, etc. (reduced thickness bolt heads, hollow bolts, half nuts, thin wall nuts, etc. prohibited). Maximum depth of flywheel shield is 8 5/8 inches, except Top Fuel, Funny Car,

TAD, TAFC, and Advanced E.T., maximum depth 9.4 inches (inside). Maximum thickness of all motor plates, mid-plates, and mounting plates installed between engine and flywheel shield is 1/2-inch, except SFI 6.1 which may be 1 1/4-inch maximum. All covers and fasteners associated with the flywheel shield must be installed prior to starting engine at any time, including warm-ups. Maximum spacing between flange fasteners in the flywheel shield is 7 inches. Chemical milling or any other structure-weakening procedure is prohibited. Welding to repair a flywheel shield is prohibited unless it is performed by the manufacturer and recertified by the manufacturer prior to use.

For cars equipped with an SFI 7.1 lower engine ballistic/restraint device, a maximum of two holes, each no larger than two inches in diameter (or 3.14 square inches equivalent area) are permitted. The holes must be located entirely below the horizontal centerline of the crankshaft. The holes must be at least 0.5-inch from any bellhousing bolt hole and be separated by at least two inches. SFI 6.2 flywheel shields may have one two-inch maximum diameter hole in the bottom of the back face of the shield. The opening in the motor plate for the crankshaft flange may not exceed the crankshaft flange diameter by more than one inch (except as noted for Top Fuel and Funny Car).

2:7 FLYWHEEL SHIELD: TOP FUEL AND FUNNY CAR

Top Fuel and Funny Cars equipped with a clutch must have a flywheel shield (bellhousing) that meets SFI Spec 6.2 and is labeled accordingly. A one-piece motor plate constructed of 1/4-inch minimum thickness 4130 chrome-moly steel and fitting between the engine and flywheel shield according to the requirements of SFI Spec 2.2, 2.3, or 10.1 is required. The motor plate must be attached to the chassis at the four corners with at least two welded mounting points using minimum 3/8-inch-diameter Grade 8 bolts and full nuts. The remaining two motor plate mounting points must be at least saddles fitting around the frametrails and secured with aircraft-type clamps or bolts (hose clamps prohibited).

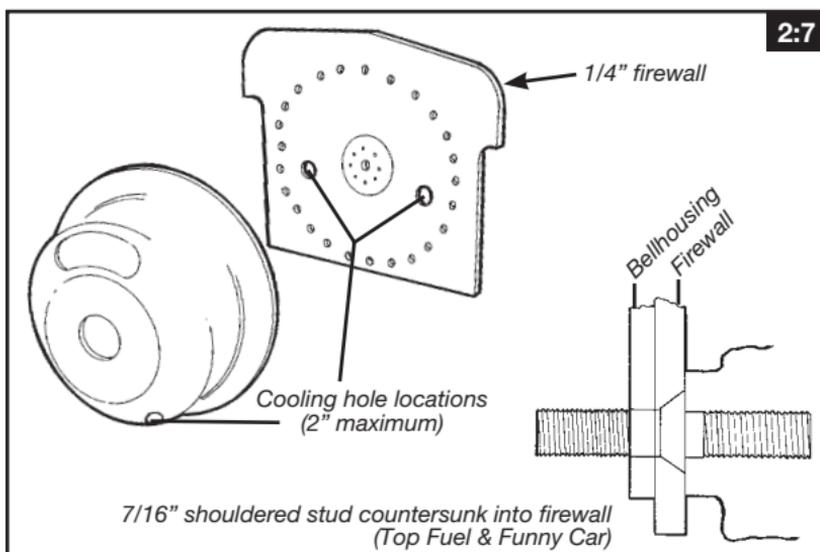

The flywheel shield and motor plate are to be fastened to the engine by at least seven high strength steel (or titanium) 7/16-inch-diameter shouldered studs countersunk (3/4-inch outside diameter) into the engine side of the motor plate and threaded into the engine (3/4-inch minimum) and nuts of a similar material above the centerline of the crankshaft. The motor plate must be fastened to the flywheel shield with at least eight 7/16-inch-diameter Grade 8 bolts or high strength steel alloy (or titanium) studs and nuts below the centerline of the

crankshaft. The flywheel shield must also be fastened to the motor plate by four 3/4-inch-diameter Grade 5 shoulder bolts or high strength steel (or titanium) fasteners and nuts; one in each quadrant as required by SFI Spec 2.3 or 10.1.

A minimum .090-inch 4130 steel or titanium liner (or as required by the manufacturer) must be fitted to the flywheel shield that is the width of the round body surface of the shield. It must be welded together so that it will fit into the body of the flywheel shield and rotate to absorb energy. A 1/4-inch aluminum bolt may be threaded into the body of the flywheel shield to secure the liner(s) from movement during normal use. The opening in the motor plate to accommodate the crankshaft flange cannot exceed 7.000 inches.

At least five fasteners, 3/8-inch-diameter minimum, must be used to secure aftermarket planetary transmissions (and/or reversers) to flywheel shield. 1/2-inch-thick rings, bosses, or nuts must be welded or otherwise secured inside the back face of the flywheel shield through which the fasteners must be secured.

As described in Section 2:6, any modifications or alterations to the bellhousing by anyone other than the original manufacturer are prohibited. Bellhousing must be recertified by original manufacturer following modification. Clutch adjustment slots, maintenance holes and covers, etc. must be installed by the original manufacturer. See General Regulations 2:6.

2:8 FLYWHEEL SHIELD: TOP ALCOHOL DRAGSTER AND TOP ALCOHOL FUNNY CAR

Top Alcohol Dragsters and Top Alcohol Funny Cars equipped with a clutch must have a flywheel shield (bellhousing) that meets SFI Spec 6.2 and is labeled accordingly. All requirements for Top Alcohol Dragster and Top Alcohol Funny Car bellhousing installations are the same as for Top Fuel and Funny Car with the following exceptions:

A one-piece motor plate constructed of 1/4-inch minimum thickness 2024 T3, 6061 or 7075 T6 aluminum and fitting between the engine and flywheel shield according to the requirements of SFI Spec 2.2, 2.1, or 10.1 is required. The motor plate must be attached to the chassis at the four corners with at least two welded mounting points utilizing minimum 3/8-inch-diameter Grade 8 bolts and full nuts. The remaining two motor plate mounting points must be at least saddles fitting around the framersails and secured with aircraft-type clamps or bolts (hose clamps prohibited).

The flywheel shield and motor plate are to be fastened to the engine by at least seven 3/8-inch-diameter Grade 8 bolts or high strength steel or titanium studs threaded into the engine (3/4-inch minimum) and nuts of a similar material, above the centerline of the crankshaft. The motor plate must be fastened to the flywheel shield with at least eight 3/8-inch-diameter Grade 8 bolts or high strength steel alloy (or titanium) studs and nuts below the centerline of the crankshaft. The flywheel shield must also be fastened to the motor plate by four 3/4-inch-diameter Grade 5 shoulder bolts or high strength steel (or titanium) fasteners and nuts; one in each quadrant as required by SFI Spec 2.1 or 10.1. Top Alcohol Dragster and Top Alcohol Funny Car: The opening in the motorplate for the crankshaft flywheel flange may not exceed the crankshaft diameter by more than one inch. See General Regulations 2:6.

2:9 FLYWHEEL SHIELD: PRO STOCK AND COMP

As described in Section 2:6, any modifications or alterations to the bellhousing by anyone other than the original manufacturer

are prohibited. Bellhousing must be recertified by the original manufacturer following modification. Clutch adjustment slots, maintenance holes and covers, etc. must be installed by the original manufacturer.

See Section 2:6 for motor plate and general requirements. The flywheel shield must be fastened to the engine and motor plate with a full complement (all available engine bolt holes or as specified by the manufacturer) of minimum 3/8-inch-diameter Grade 8 bolts or high strength steel studs above the centerline of the crankshaft. The motor plate must be fastened to the flywheel shield with at least eight 3/8-inch-diameter Grade 8 bolts or high strength steel alloy (or titanium) studs and nuts below the centerline of the crankshaft. An opening in the motor plate for an alternative starter location is permitted but it may not exceed 2 inches in diameter and when such an opening is present only one cooling hole is permitted in the motor plate.

2:10 FLYWHEEL SHIELD: OTHER CLASSES

All other cars using a clutch and running 11.49 or quicker must be equipped with an SFI 6.1, 6.2, or 6.3 flywheel shield. See Section 2:6 for motor plate and general requirements. There shall be a minimum of seven 3/8-inch-diameter Grade 8 bolts or high strength steel studs in the top half of the bellhousing. There shall be a minimum of eight 3/8-inch-diameter Grade 8 bolts or high strength steel studs in the bottom half of the bellhousing used to fasten the bellhousing to the motor plate. Modifications or repairs to the flywheel shield prohibited except if performed and recertified by manufacturer.

Exceptions to this rule: Volkswagen and Porsche engine cars are not required to have a shield when the engines are normally aspirated and gasoline burning. Porsche engines must use a steel billet flywheel. All other RWD cars running 11.49 or quicker for which an SFI 6.1, 6.2, or 6.3 flywheel shield is not commercially available may use an SFI 6.1, 6.2, or 6.3 flywheel shield from another application and mount it to a motor plate that is mounted to the engine block at all available bolt holes; or must be equipped with a flywheel shield made of 1/4-inch minimum thickness steel plate, securely mounted to the frame or frame structure and completely surrounding the bellhousing 360 degrees. The flywheel shield shall not be bolted to either the bellhousing or engine. The flywheel shield must extend forward to a point at least 1 inch ahead of the flywheel and 1 inch to the rear of the rotating components of the clutch and pressure plate.

All front-wheel-drive or transverse-mounted applications using a clutch and running 11.49 or quicker, for which an SFI Spec 6.1, 6.2, or 6.3 flywheel shield is not commercially available, must be equipped with a flywheel shield made of 1/4-inch minimum thickness steel plate. Shield must surround the bellhousing completely except for area of bellhousing adjacent to differential and axle shaft. Shield may be multi-piece, with pieces bolted together using minimum 3/8-inch-diameter Grade 5 or M10 class 8.8 bolts; may be attached to engine and/or bellhousing.

Titanium flywheel shields are permitted only in Top Fuel, Funny Car, Pro Stock, Top Alcohol Dragster, Top Alcohol Funny Car, Comp, Super Comp, Super Gas, Advanced E.T., and E.T.

2:11 REAR END

Welded spider gear rear ends prohibited in all classes. Four-wheel drive permitted per class requirements. Aftermarket axles and axle-retention device mandatory on Top Fuel, Funny Car, Pro Stock, Top Alcohol Dragster, Top Alcohol Funny Car, Comp, Super Comp, Super Gas, Super Street, and 10.99 or quicker E.T. cars; also

mandatory on any car (regardless of class or E.T.) with a spool.

2:12 TRANSMISSION

All cars and trucks in competition except motorcycle- or snowmobile-powered dragsters must be equipped with a reverse gear.

2:13 TRANSMISSION, AFTERMARKET PLANETARY

A transmission shield covering transmission and reverser that meets SFI Spec 4.1 is mandatory if engine burns nitromethane; or engine burns methanol or nitrous oxide and runs 9.99 seconds or quicker; or vehicle runs 7.49 seconds or quicker; or engine is supercharged or turbocharged; or on any overdrive unit. Air shifter bottles must be stamped with DOT-1800 pound rating (minimum) and be securely mounted (i.e., no tie-wraps or hose clamps).

At least three bolts, 3/8-inch minimum, must be used to secure aftermarket planetary transmissions to bellhousing, except as noted in Top Fuel, Funny Car, Top Alcohol Dragster, and Top Alcohol Funny Car.

2:14 TRANSMISSION, AUTOMATIC/NHRA-ACCEPTED

All cars running 10.99 (*6.99) seconds and quicker must have an NHRA-accepted locking-type dipstick on the transmission, and dipstick/filler tubes must be securely fastened (i.e., bolted, aircraft clamped). Wire ties, hose clamps, etc. prohibited.

Any non-OEM automatic floor-mounted automatic transmission shifter must be equipped with a spring-loaded positive reverse lockout device to prevent the shifter from accidentally being put into reverse gear. Functional neutral safety switch mandatory. All transmission lines must be metallic or high-pressure-type hose. All vehicles running quicker than 10.99 seconds (*6.99) or faster than 135 mph (except some Stock and Super Stock classes as noted under Class Requirements) and using an automatic transmission must be equipped with a transmission shield meeting SFI Spec 4.1 and labeled accordingly. ("Blanket"-type shield, appropriately labeled as meeting SFI Spec 4.1, permitted.) All non-blanket-type shields must incorporate two (or one, per manufacturer's instructions) 3/4 x 1/8-inch straps that bolt to the shield on each side and pass under the transmission pan, or transmission pan must be labeled as meeting SFI Spec 4.1. Permitted in all classes where an automatic transmission is used.

Comp, Super Comp, Super Gas, 9.99 or quicker E.T. cars, and 135-mph or faster E.T. cars using an automatic transmission, Lenco Drive, or BRT must be equipped with a flexplate meeting SFI Spec 29.1 and covered by a flexplate shield meeting SFI Spec 30.1. Transmission that can utilize a high-gear transbrake must be supported by the use of two momentary buttons (one to arm the system, second as the main transbrake). Air shifter bottles must be stamped with DOT-1800 pound rating (minimum) and be securely mounted (i.e., no tie wraps or hose clamps).

BRAKES & SUSPENSION: 3

3:1 BRAKES

Brakes on each car, regardless of class, must be in good working order with two-wheel hydraulic brakes on rear wheels as a minimum requirement. Four-wheel hydraulic brakes are recommended, or as specified under Class Requirements. Lightening of backing plates, brake drums, and/or brake shoes by cutting or trimming metal prohibited. Cooling or lightening holes may not be drilled in cast iron disc brake rotors. Aluminum rotors prohibited. If hand brake is used, brake handle must be inside car body or driver compartment. Brake lines must be steel,

steel braided, or DOT-approved flexible and routed outside the framerail, or enclosed in a 16-inch length of 1/8-inch minimum wall thickness steel tubing securely mounted where line(s) pass the flywheel bellhousing area and not routed in the driveline tunnel. All brake lines must be attached to chassis as per OEM style; hoses must have mounting brackets; no tie wraps, tape, etc. All brake lines on any rear-engine car must be protected inside of tubing or be braided steel construction where they pass the engine. All pedals must be covered with non-skid material. Secondary braking systems are permitted. NHRA-accepted hand controls for the physically challenged permitted. Automated braking systems prohibited; application and release of brakes must be a direct function of the driver; electronics, pneumatics, or any other device may in no way affect or assist brake operation. NHRA-accepted mechanical ABS systems permitted in all classes; contact NHRA Technical Department headquarters. If brake system includes a differential pressure switch, line-loc installed on front brakes must have solenoid installed after the differential switch. All line-locs (electric or hydraulic) must be self-returning to normal brake operating mode.

3:2 SHOCK ABSORBERS

Each car in competition must be equipped with one operative shock absorber for each sprung wheel. Shock absorbers may be either hydraulic or friction type, securely mounted, and in good working order. See Class Requirements.

3:3 STEERING

Each car's steering system must be secure and free of defects. All butt-welded parts must have additional visible reinforcement. Only conventional automotive steering systems are permitted; flexible steering shafts prohibited. Rear-wheel steering prohibited, unless vehicle was originally manufactured with an OEM system. An OEM system may not be modified, altered, or used in any manner inconsistent with manufacturer's specifications. All rod ends must be a minimum of 3/8-inch shank diameter and must be installed with flat washers of sufficient outside diameter to prevent bearing pullout. All steering boxes, sectors, and shafts must be mounted to the frame or suitable crossmember and cannot be mounted in any case to the bellhousing and/or bellhousing adapter shield, or motor plate. A secondary steering shaft stop must be installed to prevent long steering shaft from injuring driver in case of frontal impact (i.e., collar or U-joint pinned at crossmember, bracket, etc.). Commercially available quick-disconnect steering wheels permitted (except as noted in Class Requirements). Adapter must be welded to shaft. All fasteners must be of a positive nature; no roll or pressed pins, no ball-lock pins, set screws, etc. NHRA-accepted swing-away steering column permitted with removable steering wheel.

3:4 SUSPENSION

All cars must have a full suspension system of the type produced by an automobile manufacturer (i.e., springs, torsion bars, etc.). Rigid-mount front and/or rear axles are permitted when so indicated in Class Requirements. All rod ends must be installed with flat washers of sufficient outside diameter to prevent bearing pullout. Hollow rod ends are prohibited.

With the exception of unaltered OEM production Can-Am Spyder three-wheel motorcycles, three-wheel vehicles are not eligible for competition in any class. Radius rods are not required on front axles that are rigidly mounted 18 inches or less from kingpin axis. Any front suspension using a beam or tubular axle must have radius rods attached to frame.

3:5 TRACTION BAR ROD ENDS

Minimum requirement for rod ends on the front of all ladder-type traction bars is 3/4-inch steel. A rod end strap to keep ladder

bar secured in event of rod end failure mandatory in all classes. All traction devices that are not attached at front (i.e., slapper bars, etc.) must have a U-bolt or strap to prevent them from coming in contact with track.

3:6 WHEELIE BARS

Some classes limit length of wheelie bar — see Class Requirements. All wheelie bars, regardless of class, must have non-metallic wheels (i.e., rubber, plastic). Wheelie-bar wheels must turn freely at starting line, any preload prohibited. Wheelie bars must be fixed. Hydraulics, pneumatics, electronics, etc. or any adjustment or movement during run prohibited. Using wheelie-bar wheels as “fifth wheel” sensing device prohibited.

FRAME: 4

4:1 ALIGNMENT

Each car in competition, regardless of class, must have sufficient positive front-end alignment to ensure proper handling of car at all speeds.

4:2 BALLAST

As permitted in Class Requirements. Any material used for the purpose of adding to a car's total weight must be permanently attached to the car's structure and must not extend in front of or behind the rear of the car's body or above the rear tires. No liquid or loose ballast permitted (i.e., water, sandbags, rocks, shot bags, metal weights, etc.). Discovery of loose or disguised ballast will result in disqualification from the event, regardless of whether infraction occurs during qualifying or eliminations. Additional penalties may be imposed in the sole and absolute discretion of NHRA. Weight boxes (two maximum) made of 1/8-inch material may be constructed to hold small items such as shot bags, lead bars, etc., as long as box and contents do not weigh more than 100 pounds or as outlined in Class Requirements. The box must be securely fastened to the frame or crossmember with at least two 1/2-inch-diameter steel bolts. Any liquid other than engine fuel being used, located behind the front firewall (on a front-engine car), is considered ballast and is prohibited, except for intercooler tanks that contain water and/or ice only. Tank must be securely mounted to frame, frame member, or OEM floor pan. To permit “making a class” due to a difference in scale calibration, a maximum removable weight of 100 pounds (or as outlined in Class Requirements) is permitted. Removable weight must be securely mounted to the frame or frame structure by a minimum of two 1/2-inch-diameter steel bolts per 100 pounds, or one 3/8-inch steel bolt per 5 pounds; all other weight bars, pucks, etc. must use minimum 1/2-inch-diameter SAE grade 8 bolts for attachment. Hose clamps, wire, strapping, tape, tie wraps, etc. for securing weight or ballast prohibited. Acceptable forms of ballast are 1) Heavier gauge steel floors (i.e., 16- or 18-gauge, heavier gauge and/or plate steel prohibited); 2) Frame reinforcing cross members; or 3) the addition of protective equipment such as roll bars, flywheel shield, etc. If additional ballast is needed and is permitted by Class Requirements, it must be permanently attached to frame, bolted with two 1/2-inch-diameter bolts per 100 pounds, with nuts welded to bolts. Maximum amount of removable and/or permanent ballast, unless otherwise stated under Class Requirements, is 500 pounds. Cars running 8.49 and quicker are limited to 250 pounds maximum, per SFI chassis specification.

4:3 DEFLECTOR PLATE

All rear-engine cars must have a deflector plate to protect driver and fuel tank from engine. For Top Fuel and Top Alcohol Dragster specifications, see Class Requirements. Plates must be made of minimum 1/8-inch aluminum or .060-inch steel or

titanium. Must extend from top blower pulley to bottom pulley and be at least 1 inch wider than each pulley for supercharged cars. Other cars must have plate covering from shoulder height to bottom of chassis. On any enclosed engine/driver configuration, a full bulkhead must be installed, completely sealing the driver from the engine. Minimum attachment for any plate is four 5/16-inch, Grade 5 bolts. Absolutely no components may be mounted to the helmet shroud or deflector plate above the top of the shoulder hoop. See 1:1 COOLING SYSTEM for additional requirements.

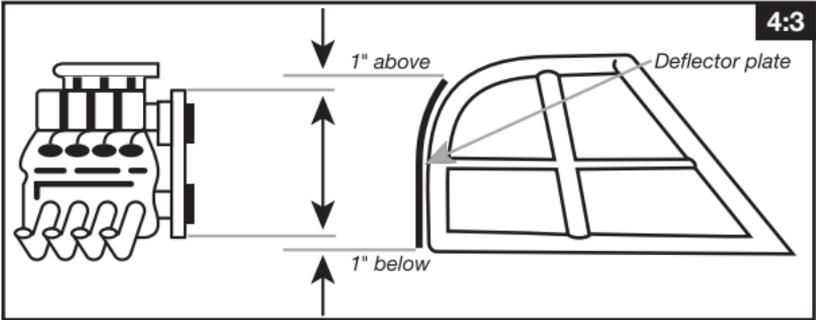

4:4 FRAMES

Pressurization of framersails, roll bar, or roll cage in lieu of air bottles is prohibited. All Top Alcohol Dragster chassis must incorporate standardized tow hookup tube (see illustration) for ease of removal in the event vehicle does not clear the racetrack under its own power. Top Fuel dragster chassis must incorporate either the standard tow hookup tube (see illustration) or an NHRA-accepted tow hook loop attached to the front of the front wing mounting tube. See also 4:10 ROLL BAR and 4:11 ROLL CAGE.

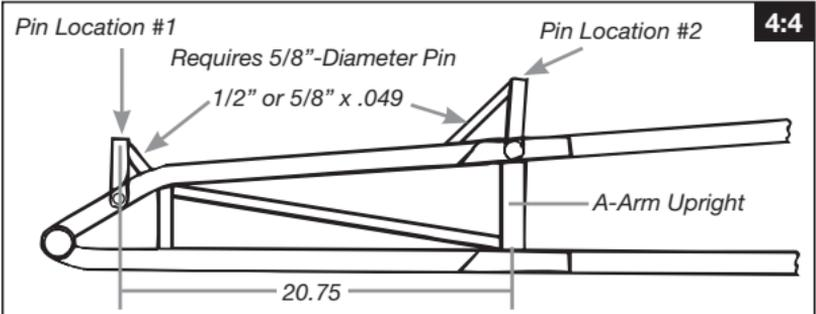

4:5 GROUND CLEARANCE

Minimum 3 inches from front of car to 12 inches behind centerline of front axle; 2 inches for remainder of car, except oil pan and exhaust headers where permitted. When permitted under Class Requirements, devices used for anti-rotation purposes (i.e., wheelie bars) are exempt from the 2-inch clearance rule. Unless otherwise permitted by Class Requirements, the installation of a “beam breaker” in front of the body is restricted to extending no farther forward than the body or bumper and must also satisfy the 3-inch ground-clearance requirement.

4:6 MAGNAFLUX CERTIFICATES

Magnaflux certificates may be required by the technical inspector on any altered or welded parts.

4:7 MOUNTING HARDWARE

Hose clamps and tie wraps may be used only to support hoses and wires; all other components must be welded, bolted, aircraft clamped, etc. All self-locking fastener buttons must be metallic. All self-locking fastener buttons may be painted any color on their face, but must be WHITE or SILVER ONLY under the face. This rule applies to ALL cars in ALL classes. All electrical, instrumentation, etc. connection boxes (e.g., exhaust temperature

sensor/data recorder boxes and similar components) must either be securely (no wire ties, hose clamps, Velcro, etc.) attached to the engine, frame, bellhousing, etc. OR be constrained by a .060-inch-diameter stainless-steel multi-strand cable/lanyard such that it will not drop to the ground or contact a tire if any of the connecting wires break, OR be located such that they will fall into the body/belly pan if any of the connecting wires break.

4:8 PARACHUTES

If outlined in Class Requirements, it is mandatory to have a braking parachute produced by a recognized drag racing parachute manufacturer. Dual parachutes required for all cars running 200 mph or more or if required by Class Requirements. Tech inspectors may observe the proper operation of the parachute(s) and inspect for worn or frayed shroud lines, ripped or dirty canopies, and worn or ragged pilot chutes. Parachute cable housings should be mounted solidly to frame tube or other suitable member no farther back than 1 inch from the release handle. If automated push-button release system is used, driver must also be able to use handle to manually release the parachute(s). The release housing must be attached within 12 inches of the parachute pack and in a manner that will allow the inner cable to release the parachute. When supercharged or using nitromethane as a fuel, it is mandatory that the parachute pack and unpacked shroud lines be protected with fire-resistant material from the mounting point to the pack. Parachutes must have their own independent mounting with sleeved 3/8-inch minimum steel bolts or steel pins required for all applications unless otherwise stated in Class Requirements. The use of ball-lock pins for parachute mounting prohibited. Applications using two parachutes are required to have separate mounting points for each parachute system. Shroud line(s) mounting brackets must be constructed of minimum .090-inch steel unless otherwise stated in Class Requirements. Safety pins must be red flagged and removed prior to burnout.

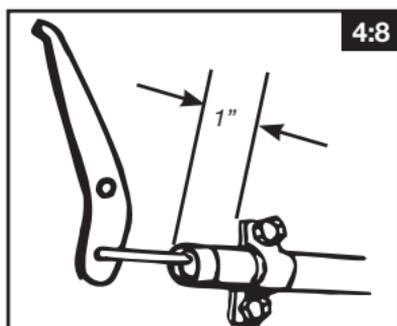
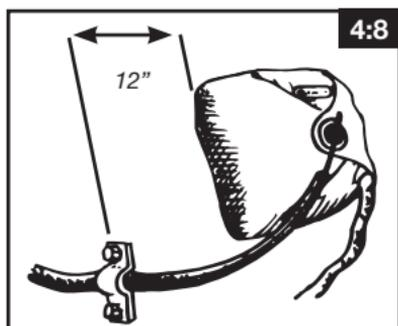

4:9 PINION SUPPORT

All cars using an open driveline must have radius arms, traction bars, or some suitable pinion support to prevent rear-end housing rotation.

4:10 ROLL BAR

All roll bars must be within 6 inches of the rear, or side, of the driver's head, extend in height at least 3 inches above the driver's helmet with driver in normal driving position or be within 1 inch of the roof/headliner in the area above the driver's helmet, and be at least as wide as the driver's shoulders or within 1 inch of the driver's door. Roll bar must be adequately supported or cross-braced to prevent forward or lateral collapse. Rear braces must be of the same diameter and wall thickness as the roll bar and intersect with the roll bar at a point not more than 5 inches from the top of the roll bar. Crossbar and rear braces must be welded to main hoop. Sidebar must be included on driver's side and must pass the driver at a point midway between the shoulder and elbow. Swing-out sidebar permitted. All roll bars must have in their construction a cross bar for seat bracing and as the shoulder

harness attachment point; cross bar must be installed no more than 4 inches below, and not above, the driver's shoulders or to side bar. All vehicles with OEM frame must have roll bar welded or bolted to frame; installation of frame connectors on unibody cars does not constitute a frame; therefore it is not necessary to have the roll bar attached to the frame. Unibody cars with stock floor and firewall (wheeltubs permitted) may attach roll bar with 6-inch x 6-inch x .125-inch steel plates on top and bottom of floor bolted together with at least four 3/8-inch bolts and nuts, or weld main hoop to rocker sill area with .125-inch reinforcing plates, with plates welded completely. Also, the roll bar may be welded to frame connectors that are fully welded in place and are 1 5/8 inches x .118-inch MS or .083-inch CM round and/or 2 inch x 2 inch x .058 MS or CM rectangular. All 4130 chromoly tube welding must be done by approved TIG heliarc process; mild steel welding must be done by approved MIG wire feed or approved TIG heliarc process. Welding must be free of slag and porosity. Any grinding of welds prohibited. See illustration. Roll bar must be padded anywhere driver's helmet may contact it while in driving position. Adequate padding must have minimum 1/4-inch compression or meet SFI Spec 45.1. All cars running 9.99 (*6.39) or quicker, SFI Spec 45.1 mandatory.

4:11 ROLL CAGE

All roll cage structures must be designed in an attempt to protect the driver from any angle, 360 degrees. All 4130 chromoly tube welding must be done by approved TIG heliarc process; mild steel tube welding must be approved MIG wire feed or TIG heliarc process. Welding must be free of slag and porosity. Any grinding of welds prohibited. All butt welds must have visible reinforcement (i.e., sleeve and rosette welds). Visible reinforcement around any hole in any SFI Spec chassis (not just the roll cage) mandatory. Reinforcement must be of at least the same cross-sectional area as the hole, at least .049-inch-thick chromoly and completely welded around the outside. Plating of chassis prohibited for cars running 7.49 and quicker manufactured after Jan. 1, 1999 and for all cars manufactured after Jan. 1, 2003, regardless of e.t. or speed. Painting and powder coating of chassis permitted. Top

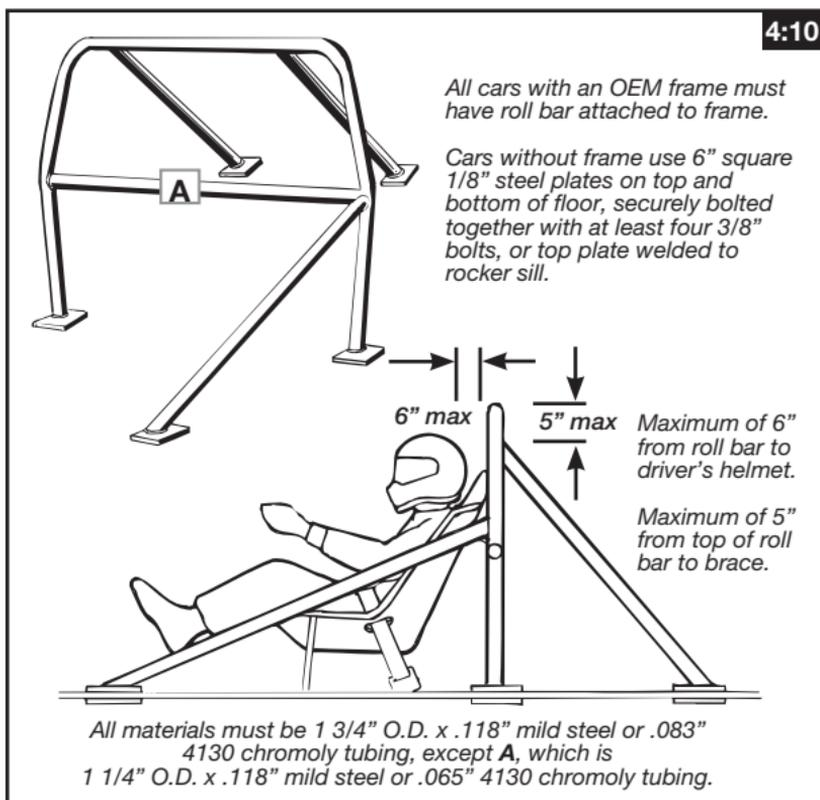

Fuel, Funny Car, Pro Stock, Top Alcohol Dragster, Top Alcohol Funny Car, Comp, Super Stock, Stock, Super Comp, Super Gas, and 9.99 or quicker E.T. chassis (see Class Requirements) must have a serialized chassis sticker affixed to frame before participating in any NHRA member track event. Certifications are available at NHRA Mello Yello Drag Racing Series national events, NHRA Lucas Oil Drag Racing Series events, or by making prior arrangements through a division office. All chassis must be recertified every three years unless otherwise specified in Class Requirements. Roll cage must be padded anywhere the driver's helmet may contact it. For all cars running 9.99 (*6.39) and quicker, this padding must meet SFI Spec 45.1. To determine which type of roll cage your car needs, refer to illustrations in this section as well as specific Class Requirements for the applicable e.t. and body-style roll-cage requirements. Open-bodied cars running 9.99 and quicker and/or faster than 135 mph, all rear-engine dragsters, and all street roadsters must meet applicable SFI Specification for e.t. (see Class Requirements). Full-bodied cars running 8.49 and quicker and/or exceeding 180 mph must meet applicable SFI Specification for e.t. and weight (see Class Requirements). Full-bodied cars running between 8.50 and 9.99 and slower than 180 mph must meet the NHRA Full-Bodied roll cage requirements found in the illustration in this section. Front-engine dragsters, altereds, and Funny Cars running slower than 10.00 seconds must meet their respective NHRA roll cage requirements found in the illustrations in this section. SFI Specifications may be purchased from the SFI Foundation (sfi.foundation.com, 858-451-8868); SFI Specifications are not available from NHRA Technical Services.

OPEN-BODIED CARS

When driver is in driving position in an open-bodied car, roll cage must be at least 3 inches in front of helmet. Cars without crossmember above driver's legs must have a strap or device to prevent legs from protruding outside chassis. On front-engine dragster, seat uprights and back braces must be arranged such that a flat surface passed over any two adjacent members will not contact the driver's seat or containment. Additional uprights, max 30 degrees from vertical, must be added until this requirement is satisfied. When non-vertical upright or "running W" side bay designs are used (i.e., uprights installed at greater than 30 degrees from vertical), adjacent roll-cage diagonals must be the same size as that required for the upright. Motor mount and/or rear-end uprights (except rear-engine dragster) may be rectangular tubing, 1 3/4-inch x 1-inch x .058 CM or MS minimum.

For all vehicles required to meet SFI Specification 2.1, 2.2, 2.3, 2.4, 2.5, 2.6, 2.7, 10.1 and 10.4 the upper roll-cage members must have head/helmet guards of one-inch by .058-inch round tube.

FULL-BODIED CARS

On full-bodied cars with the driver in driving position, helmet must be in front of main hoop. If helmet is behind or under main hoop, additional tubing same size and thickness as roll cage must be added to protect driver. Main hoop may be laid back or forward, but driver must be encapsulated within the required roll-cage components. For cars being built to the Rulebook Spec (i.e., 8.50 seconds e.t. and slower), there are times when it is not practical to fully weld the windshield bar and/or the main hoop to its adjacent structure. In this case, the use of two (i.e., two per affected joint) 1 3/4-inch x 1 3/4-inch x .110-inch 4130 chromoly or mild steel plate gussets, fully welded on one side, may be used to replace up to 25 percent of the weld. These plate gussets may have a maximum of one 1/2-inch-diameter and two 5/16-inch-diameter holes. Another option to correct these incomplete welds is to use two, fully welded, tube gussets per affected joint. These tube

gussets must be a minimum of 3/4-inch x .049 4130 chromoly or 3/4-inch x .118-inch mild steel and at least 4 inches in length. These gussets are an acceptable correction to incomplete welds only in the OEM roof area. On unibody cars with stock floor and firewall (wheel tubs permitted), the roll cage may be bolted or welded to the floor/rocker box via 6-inch x 6-inch x .125-inch steel plates similar to the roll-bar attachment requirements of paragraph 4:10 in this section. Unless attaching to OEM floor or frame, the minimum requirements for a frame member or fully welded in place frame connectors on unibody cars to which a roll-cage member is attached are 1 5/8-inch x .118-inch MS or .083-inch CM round and/or 2-inch x 2-inch x .058 MS or CM rectangular. All cage structures must have in their construction a cross bar for seat bracing and as the shoulder harness attachment point; cross bar must be installed no more than 4 inches below, and

STREET ROADSTER (10.00 (*6.40) seconds e.t. and slower)

TOP VIEW FROM ABOVE
(roll cage removed from drawing for clarity)

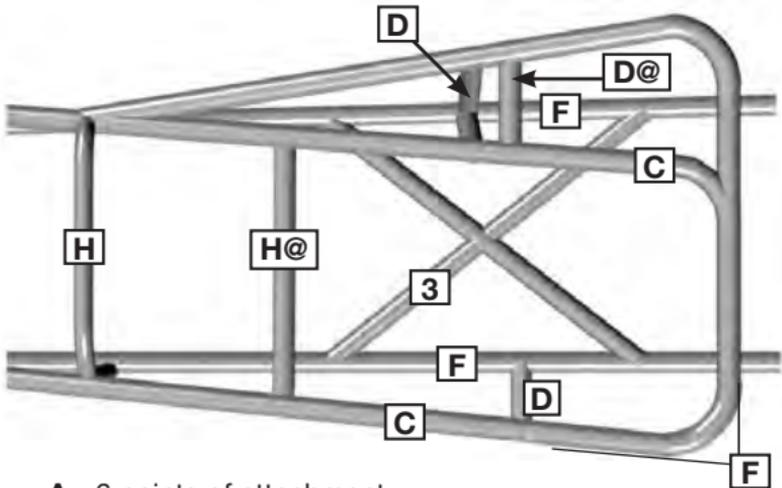

- A** - 6 points of attachment
- D@** - Horizontal, 1 1/4" x .058" used to tie inner and outer upper frame, only when no other support exists
- F** - **Lower frame** - needs extension on left side when driver's seat is overhanging lower frameraill
- H** - Foot box support 1" x .058"
- H@** - Retention for driver's legs, also can be a dash mount 1" x .058"
- 3** - Single diagonal 3/4" x .058"
X or K design 5/8" x .058"

When 1 5/8" x .083" is used for upper **C** and lower **F** frame and uprights **D**, eliminates the need for inner frame diagonals **3**. Diagonals **3** along outer frame and uprights still mandatory

Street Roadster Tubing Code			
	O.D.	Chromoly	Mild Steel
A	1 1/2	.065	.118
C	1 1/2	.058	.118
D	1 1/4	.058	.118
	1 1/8	.065	.118
F	1 1/4	.058	.118
	1 3/8	.049	.118
I	1 1/4	.049	.118

not above, the driver's shoulders, or to side bar. All required rear braces must be installed at a minimum angle of 30 degrees from vertical and must be welded in. Side bar must pass the driver at a point midway between the shoulder and elbow.

Unless an OEM framerail is located below and outside of driver's legs (i.e., '55 Chevy, '65 Corvette, etc.) a rocker or sill bar, minimum 1 5/8-inch x .083 CM or .118 MS or 2-inch x 2-inch x .058-inch CM or MS rectangular, is mandatory in any car with a modified floor or rocker box within the roll-cage uprights (excluding 6 square feet of transmission maintenance opening). Rocker bar must be installed below and outside of driver's legs and must tie into the main hoop, the forward hoop, frame, frame extension, or side diagonal. Rocker bar may not tie into swing-out side bar support. If rocker bar ties into side diagonal more than 5 inches (edge to edge) from forward

STREET ROADSTER (10.00 (*6.40) seconds e.t. and slower)

LEFT SIDE VIEW
(Driver is on left side of driveshaft)

Helmet must be a minimum of 3" behind front bar

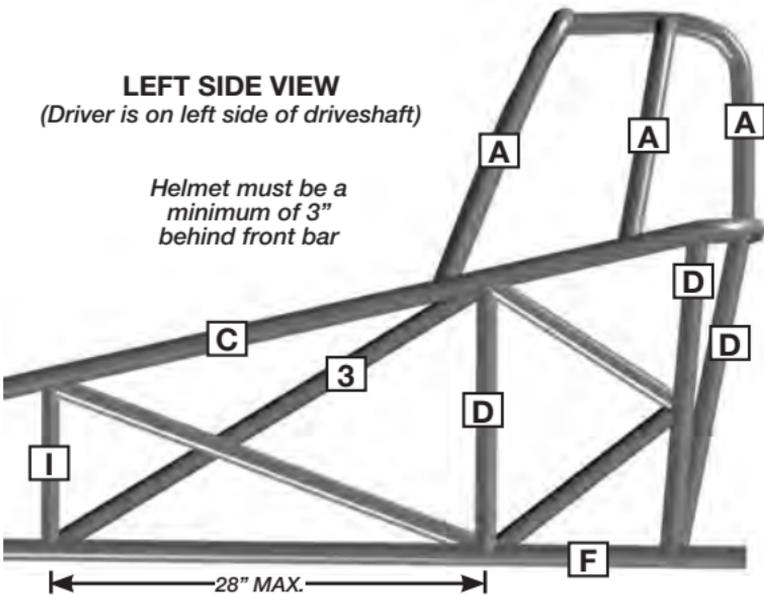

RIGHT SIDE VIEW
(Inner view, base for roll cage)

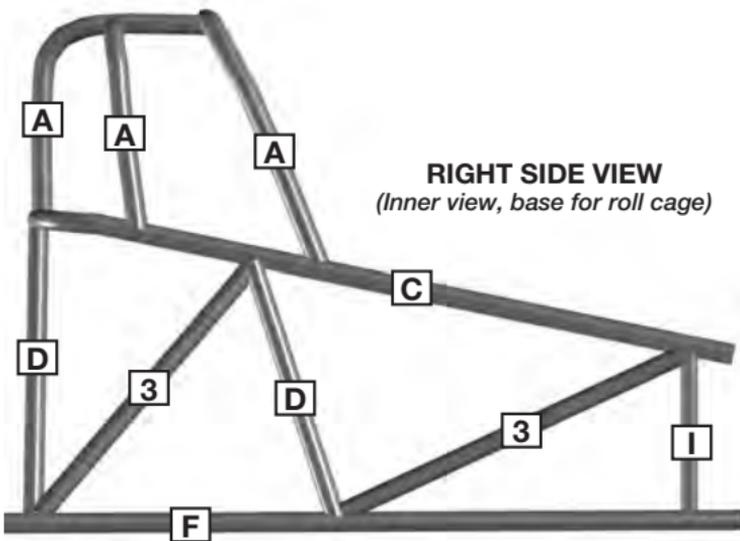

When this design is used for the inner structure, adjacent to the driver, then the outer structure has no minimum requirements.

*Mild steel construction requires .118" minimum wall thickness.
Lower frame of square tubing minimum is 2" x 2" x .058".*

REAR-ENGINE DRAGSTER

(10.00 (*6.40) seconds e.t. and slower)

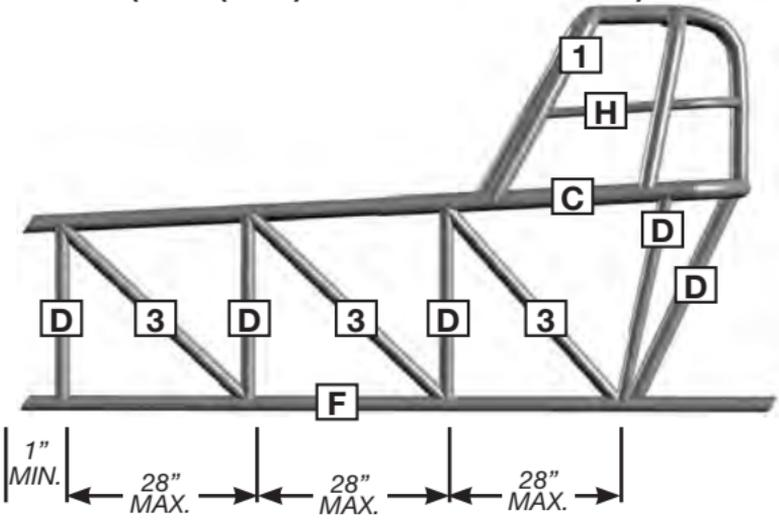

All dimensions apply to driver's compartment only

FRONT VIEWS
(Dragster; rear engine)

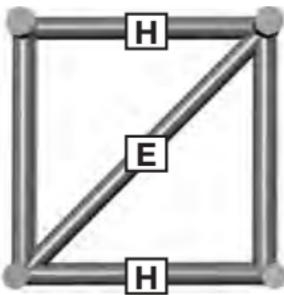

OPTION #1

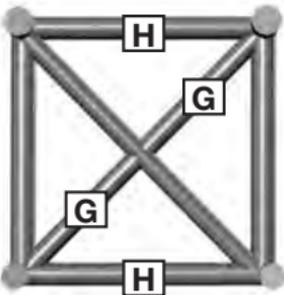

OPTION #2

BOTTOM VIEW

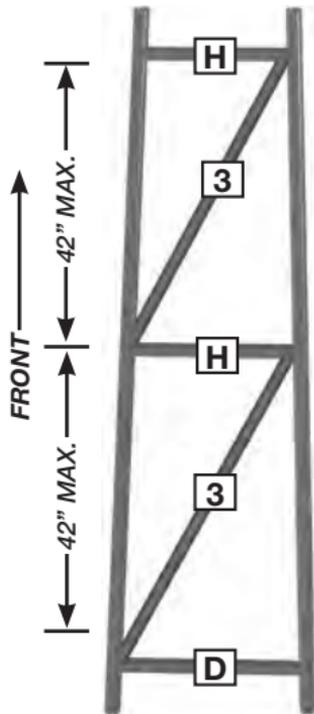

RED, FED, Altered, and Funny Car Tubing Code			
	O.D.	Chromoly	Mild Steel
A	1 1/2	.065	.118
B	1 5/8	.065	.118
C	1 3/8	.058	.118
D	1 1/4	.058	.118
E	1 1/8	.065	.118
	3/4	.058	.118
	1	.049	.118
F	1 1/4	.058	.118
	1 3/8	.049	.118
G	5/8	.058	.118
H	1	.058	.118
I	1 1/4	.049	.118

roll-cage support or main hoop, a 1 5/8-inch x .083 CM or .118 MS brace/gusset is mandatory between the diagonal and forward roll-cage support or main hoop.

“D” bar installation for full-bodied cars: For front-wheel-drive cars, with complete OEM floor (from the firewall to the rear of the trunk) and rocker/sill boxes, the 1 1/4-inch x .058-inch CM (.118-inch MS) “D” bars (when required; i.e., when the main hoop is not welded to the frame) may be welded to a 1 5/8-inch x .083-inch CM (.118-inch MS) crossmember welded to the rocker/sill box via conventional 6-inch x 6-inch x 1/8-inch-thick plates or welded to main hoop. For rear-wheel-drive cars, with neither a frame nor subframe connectors, but with complete OEM floor (from the firewall to the rear of the trunk; exception: the rear inner wheelwells may be tubbed with steel or aluminum), the 1 1/4-inch x .058-inch CM (or .118-inch MS) “D” bars may be welded to conventional 6-inch x 6-inch x 1/8-inch formfitted/contoured plates attached to the driveshaft tunnel. Otherwise, the “D” bars must be attached to frame, subframe, or subframe connectors.

Swing-out side bar permitted on OEM full-bodied car 8.50 e.t. and slower. The following requirements (a through d) apply:

- a. 1 5/8-inch O.D. x .083-inch CM or .118-inch MS minimum. Bolts/pins must be 3/8-inch-diameter steel, minimum and in double shear at both ends.
- b. Male or female clevis(es) permitted. Male clevis must use two minimum 1/8-inch-thick brackets (CM or MS) welded to each

FRONT-ENGINE DRAGSTER

(10.00 (*6.40) seconds e.t. and slower)

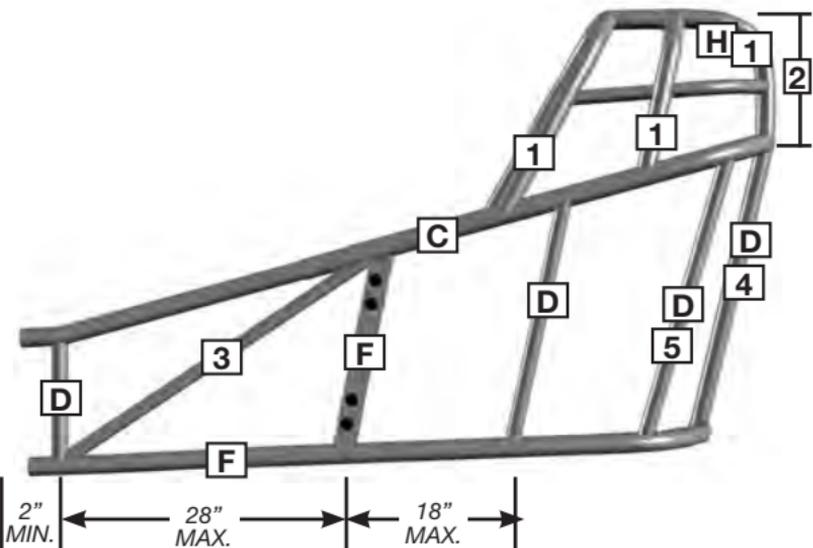

- 1 - Rear-engine dragsters with 5 or 6 points of attachment, use code **A**. Front-engine dragsters with 6 points of attachment, use 1 1/2-inch x .058-inch CM or .118-inch MS. Front-engine dragsters with 5 points of attachment, use code **B**, and **C** (upper framerail/shoulder hoop) becomes 1 1/2-inch x .058-inch CM or .118-inch MS.
- 2 - If over 18 inches, use code **B**, and **C** (upper framerail/shoulder hoop) becomes 1 1/2-inch x .065-inch CM or .118-inch MS.
- 3 - If an X or K design is used then 5/8" x .058", otherwise **E**.
- 4 - If lower framerails transition into back brace uprights, must include a 1" x .058" crossmember between back brace uprights (rear seat crossmember), min. 5 inches, max. 10 inches above lower framerails.
- 5 - "Kidney" upright.

ALTEREDS, FUNNY CARS

(10.00 (*6.40) seconds e.t. and slower)

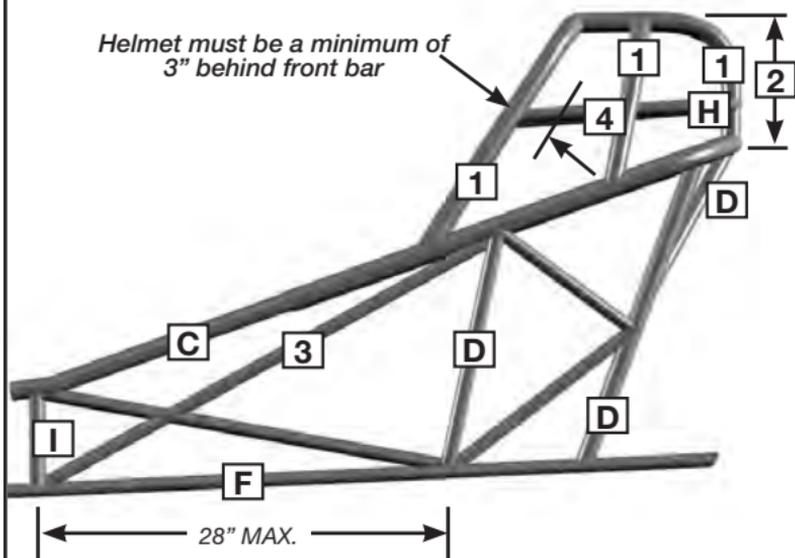

REAR VIEW
(Altered, Funny Cars,
Rear-Engine Dragsters)

- 1** - Funny Car and altered with 6 points of attachment, use 1 1/2-inch x .058-inch chrome moly (CM) or .118-inch mild steel (MS). Funny Car and altered with 5 points of attachment, use code **B**, and **C** (upper framerail/shoulder hoop) becomes 1 1/2-inch x .058-inch CM or .118-inch MS.
- 2** - If over 18 inches, use code **B**, and **C** (upper framerail/shoulder hoop) becomes 1 1/2-inch x .065-inch CM or .118-inch MS.
- 3** - If X or K design is used then 5/8" x .058", otherwise **E**.
- 4** - For Altered and Funny Cars, the **H** bar permitted.

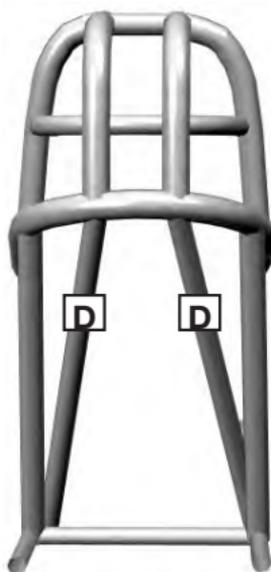

RED, FED, Altered, and Funny Car Tubing Code			
	O.D.	Chromoly	Mild Steel
A	1 1/2	.065	.118
B	1 5/8	.065	.118
C	1 3/8	.058	.118
D	1 1/4	.058	.118
	1 1/8	.065	.118
E	3/4	.058	.118
	1	.049	.118
F	1 1/4	.058	.118
	1 3/8	.049	.118
G	5/8	.058	.118
H	1	.058	.118
I	1 1/4	.049	.118

FULL-BODIED CARS

(8.50 (*5.35) seconds e.t. and slower)

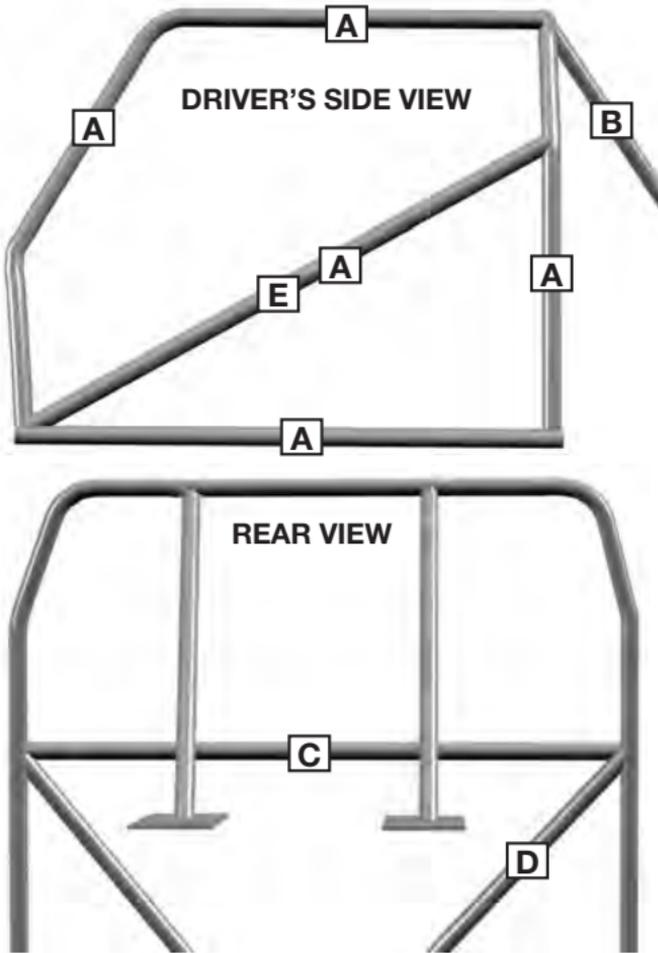

All cars with an OEM steel frame must have roll cage welded to frame. For 1997 and later Z06 and ZR1 Corvettes only with aluminum frames, the acceptable roll-cage mounting is shown in the next drawing.

- B** - If **A**, two bars any length.
 If **B1**, two bars, 30" or less; must attach within 5 inches from top of main hoop.
 If **B2**, minimum 4 bars. At least 2 bars must attach to horizontal portion of main hoop.
 If **B3**, minimum 6 bars. At least 2 bars must attach to horizontal portion of main hoop.
- D** - 1 1/4" x .058" CM (.118" MS) mandatory when main hoop is welded to plates on floor and/or rocker/sill in lieu of frame; D-bars must be attached to frame, subframe, subframe connectors, or OEM driveshaft tunnel. Refer to text in this section for specific criteria.
- E** - May substitute an "X" brace of 1 1/2 by .065-inch 4130 chromoly or 1 1/2 by .118-inch mild steel.

Tubing Code			
	O.D.	CM	MS
A	1 5/8	.083	.118
B-1	1 1/2	.058	.118
B-2	1 3/8	.049	.118
B-3	1 1/4	.049	.118
C	1 1/4	.065	.118
D	1 1/4	.058	.118
CM	4130 Chromoly		
MS	Mild Steel		

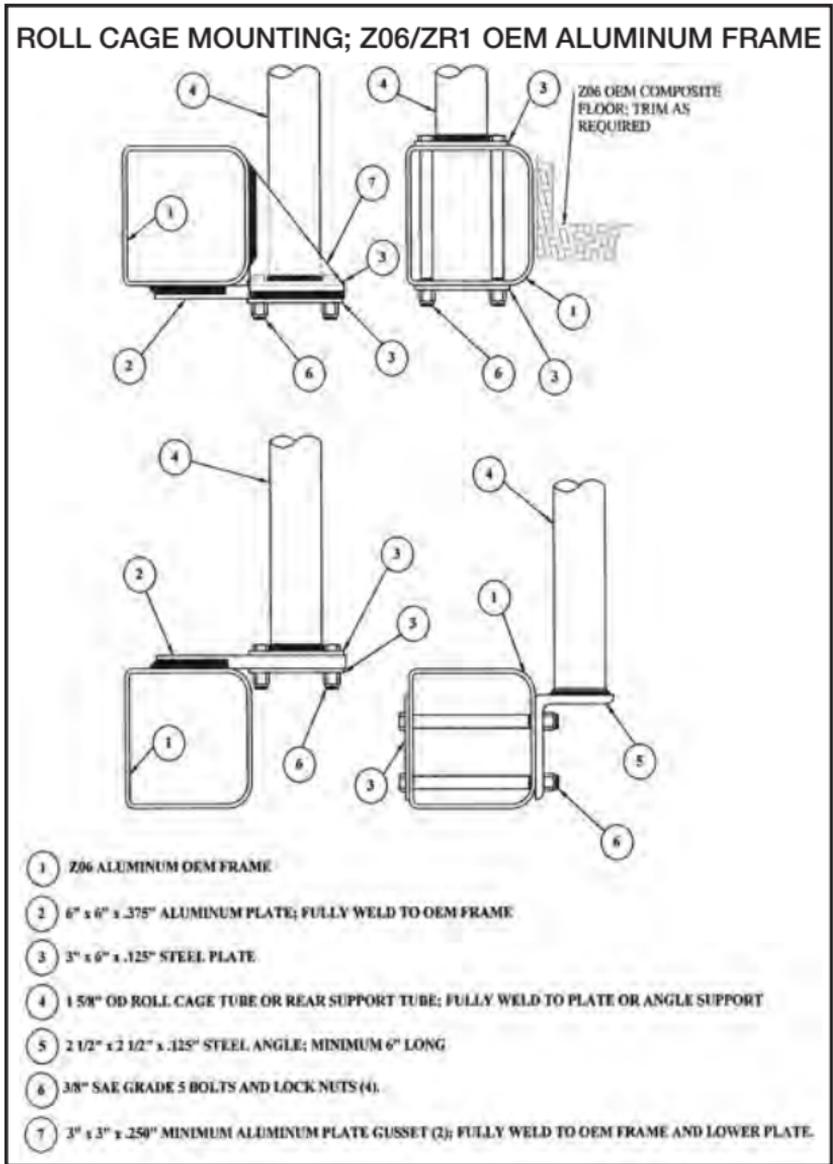

roll-cage upright; female must use minimum 1/4-inch-thick bracket (CM or MS) welded to each roll-cage upright. Pins must be within 8 inches of the vertical portion of both the forward and main hoops. A half-cup backing device must be welded to the vertical portion of the main hoop (inward side) or the upper end of the swing-out bar (outward side), minimum .118-inch wall (CM or MS) extending at least 1 5/8 inches past the center of the pins. A clevis assembly using a minimum .350-inch-thick male component and two minimum .175-inch-thick female components may use a 1/2-inch-diameter Grade 5 bolt and does not require a half-cup backing device.

c. Sliding sleeves of 1 3/8-inch x .083 CM or .118 MS, with minimum 2-inch engagement, are permitted in lieu of the upper pin/cup.

d. All bolt/pin holes in the swing-out bar must have at least one-hole diameter of material around the outside of the hole.

Steel-bodied pickup trucks (7.50 seconds and slower), roll cages are permitted with no back braces if the roll cage satisfies SFI 25.1, 25.2, 25.4, or the roll cage consists of a 4-point (door car) cage with a complete SFI 2.4, 2.5, 2.6, 2.7 dragster, SFI 10.2, 10.3 altered, or SFI 10.4 street roadster roll cage/driver's compartment incorporated into and attached to the 4-point roll cage. An upper windshield bar is mandatory.

Non-steel-bodied pickup trucks (7.50 seconds and slower), roll cages are permitted with no back braces if the roll cage satisfies

SFI 25.1, 25.2, 25.4, or the roll cage satisfies the requirements for SFI 2.4, 2.5, 2.6, 2.7 dragster, SFI 10.2, 10.3 altered, or SFI 10.4 street roadster roll cage/driver's compartment. No 4-point (door car) cage is required and no upper windshield bar is required.

On all cars requiring a roll cage, if the OEM firewall has been modified (in excess of 1 square foot for transmission removal, not including bolted in components) a lower windshield or dash bar of 1 1/4 x .058-inch 4130 chromoly or 1 1/4 x .118-inch mild steel is mandatory connecting the forward cage supports.

All joints indicated as tube-to-tube joints/intersections must be fabricated by properly notching the components to fit with minimum clearance unless otherwise noted. Crushing the end of a tube to oval in lieu of properly notching/fitting the tube is not acceptable. Welding a plate to the side of one tube and butt welding the other tube to the plate surface in lieu of properly notching/fitting the tube is not acceptable.

For Sportsman full-bodied cars that require a roll cage (7.50 seconds and slower, including cars inspected to SFI 25.4 or 25.5): If the windshield/roof bars are interrupted by the dash bar, then either the entire dash bar must be minimum 1 1/2-inch x .058-inch CM (.118-inch MS) or the entire dash bar must be minimum 1 1/4-inch x .058-inch CM (.118-inch MS) and must be braced with gussets to both the upper and lower sections of each windshield/roof bar. The gussets may be either 1.75-inch x 1.75-inch x .110-inch (with one 1/2-inch-diameter and two 5/16-inch-diameter holes maximum) 4130 CM or MS plate (triangle shaped) or 3/4-inch x .049-inch CM (.118-inch MS) tubing at least 4 inches long. An interrupted windshield/roof bar is defined as one that has been completely severed into upper and lower sections/pieces and then the sections/pieces are welded to the dash bar.

4:12 WHEELBASE

Minimum 85 inches, unless OEM was less and vehicle is equipped with OEM engine and drivetrain. Maximum wheelbase variation from left to right is 1 inch, unless otherwise noted in Class Requirements.

TIRES & WHEELS: 5

5:1 TIRES

Tires will be visually checked for condition, pressure, etc. and must be considered free of defects by the technical inspector prior to any run. All street tires must have a minimum of 1/16-inch tread depth. Temporary spares, space saver spares, farm implement or trailer tires prohibited. Metal, screw-in valve stems mandatory in tubeless tires, front and rear, on vehicles running 11.99 or quicker; unless OEM tire pressure monitor sensor is used. Chemically treating and physically altering (e.g., lightening, etc.) a tire in any manner is prohibited unless such treatment or alteration is performed by the original manufacturer.

5:2 WHEELS

Hubcaps must be removed for inspectors, who will check for loose lugs, cracked wheels, worn or oversize lug holes, and condition of spindles, axle nuts, cotter

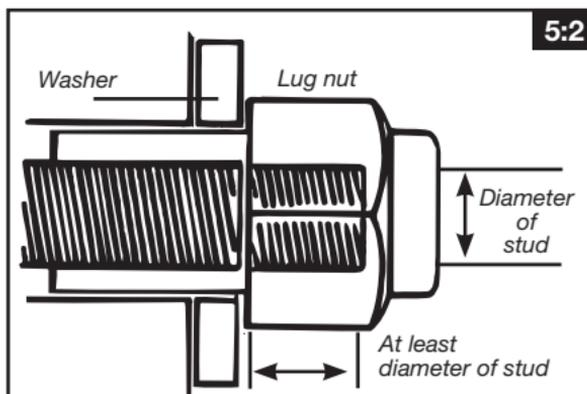

pins, etc. Snap-on hubcaps are prohibited on any class car. The use of "spinner" style wheels or any wheel design that incorporates movable pieces while vehicle is in motion or stationary are prohibited.

Each car in competition must be equipped with automotive-type wheels with a minimum 12 inches of diameter unless Class Requirements stipulate otherwise. Motorcycle wheels or lightweight automotive wire wheels must be equipped with .100-inch minimum diameter steel spokes, properly cross-laced to provide maximum strength. All spoke holes in rim and hub must be laced. Omissions to lighten wheels prohibited. The thread engagement on all wheel studs to the lug nut, or lug bolts to wheel hubs, must be equivalent to or greater than the diameter of the stud/bolt. Length of the stud/bolt does not determine permissibility. (Example: A 7/16-inch stud must be thoroughly engaged through the threads in the hex portion of the lug a minimum of 7/16-inch.)

Wheel spacer permitted. Spacer to be either hub-centric or lug-centric and must fit with minimal clearance to retain concentricity. The wheel spacer must not reduce the minimum permitted thread engagement below the limits established by fastener diameter. (See example as stated above.) No stacking of wheel spacers allowed. Maximum rim width on any car: 16 inches. No rear wheel discs or covers permitted in any category. Top Fuel and Funny Car rear wheels must meet SFI Spec 15.4. Pro Stock, Top Alcohol Dragster, Top Alcohol Funny Car, and Pro Modified (Comp) must meet a minimum of SFI Spec 15.1.

INTERIOR: 6

6:1 DRIVER COMPARTMENT

Both doors must be functional from inside and outside on all full-bodied cars. All interior panels (firewalls, floors, wheel tubs, doors, etc.) within the driver compartment of enclosed-cockpit cars where the driver is located behind the engine must be constructed of materials other than magnesium. Driver compartment of any enclosed or full-bodied car must be totally sealed from engine and transmission. Openings around all linkages, lines, wires, hoses, etc. must be minimized.

6:2 UPHOLSTERY, SEATS

The driver's seat of any car in competition must be constructed, braced, mounted, and upholstered to provide full back and shoulder support. The driver's seat must be supported on the bottom and back by the frame or crossmember. Except as noted in SFI Specifications, seats must be bolted with four bolts (and nuts and washers) on the bottom and one bolt in the rear into crossbar; all bolts must go into frame or cross braces. Ball-lock pins for seat attachment prohibited in all classes. All seats must be upholstered, or as noted under Class or SFI Requirements.

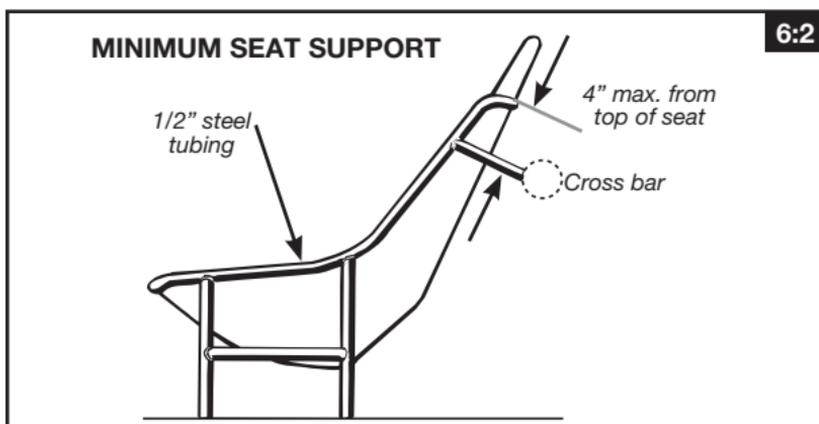

All front-engine, open-bodied, supercharged or turbocharged (gasoline or methanol) cars running 7.49 seconds and quicker must have a flame-retardant-material-upholstered seat. Properly braced, framed, supported, and constructed seats of aluminum, fiberglass, carbon fiber, or double-layer poly (accessory seats) permitted. Single-layer fiberglass seats must have steel tube framework, 1/2-inch-minimum O.D., for support. Aftermarket aluminum seats must have reinforced head rest. Magnesium seats prohibited.

6:3 WINDOW NET

An SFI 27.1 ribbon-type or mesh-type window net is mandatory on any full-bodied car running 7.49 (*4.49) or quicker. For full-bodied cars running 7.50 (*4.50) to 9.99 (*6.39) or if vehicle runs 135 mph or faster, a ribbon-type or SFI 27.1 mesh-type window net is mandatory unless otherwise specified by Class Requirements. SFI 27.1 window net, when required, must be updated at two-year intervals from the date of manufacture. Window net must be securely mounted on the inside of the roll cage, with the permanent attachment at the bottom. All attachment points must be designed in an attempt to protect the driver and avoid contact with track surface or guardwall. Eyelet clips, dogleash hardware, hose clamps, etc. prohibited. Penetration of webbing, except as performed per manufacturer's instructions, prohibited. Any other modification to net must be performed by manufacturer.

BODY: 7

7:1 AIR FOILS, WINGS

Air foils, canards, wings, and spoilers other than original factory equipment are permitted only in open-bodied class cars (e.g., Dragster, Street Roadster, or open-wheel Altered) or as noted in Class Requirements. A positive locking device to prevent movement mandatory. No part to be within 6 inches of rear tires. Spring-loaded spoilers, wings, or canards prohibited. Adjustment of air foils, wings, or spoilers during run prohibited. NOTE: A spoiler is mounted directly to the deck lid of the vehicle such that air passes only on the top side of the device. An air foil or wing is mounted on stands, struts, or pedestals such that air passes over the top and underneath the device. Minimum fastener size on all front wings, canards, etc. is 1/4-inch. Ball-lock pins prohibited.

For all open-wheel/body cars where rear wings are permitted and mounted to the roll cage, the wing may either be fully mounted to the roll cage via plates and/or short brackets; maximum 6 inches center-to-center between the upper (wing tab) and lower (roll cage tab) bolts or have a roll-cage shroud. A multi-piece shroud is permitted. The shroud must be constructed of minimum .075-inch Grade 2 ASTM-B-265 titanium or .090-inch 4130 steel and must be shaped to conform to the roll cage. The shroud must be attached to each of the side bars with a minimum of three 1/4-inch-minimum-diameter Grade 8 bolts and bosses per side, to the top with one 1/4-inch-minimum-diameter Grade 8 bolt and boss, and to the rear bars with a minimum of two 1/4-inch-minimum-diameter Grade 8 bolts and bosses per side. Tabs with bolt and nut, where the nut is welded to the tab, may be used in place of the bosses. Absolutely no components may be mounted to the helmet shroud above the top of the shoulder hoop. Bolt heads must be 1/2-inch hex-style head.

NHRA-accepted helmet shrouds must be made as a one-piece shroud, a two-piece shroud, where each half must overlap; or a three-piece shroud, that includes two side shields and the center section.

All shrouds must fully encapsulate the rear braces and the secondary roll-cage hoop on the sides and top; when viewed from the rear, the shroud must cover the complete visible roll-cage structure. On the bottom, the shroud must have 2-inch clearance between the upper framerail/shoulder hoop; on the top and sides, the entire shroud must extend fully forward to at least the centerline of the side bars.

When the shroud is fabricated as a two-piece unit, the components must overlap a minimum of 3/4-inch per side.

On a three-piece shroud, the center/rear section of the shroud may stand off from/behind the side pieces by no more than 3/4 inches at any point and must overlap each side a minimum of 1 1/2 inches. The side shrouds must extend to the centerline of the rear hoops.

7:2 COMPETITION NUMBERS

All contestants are required to display a permanent driver number at all NHRA Mello Yello Drag Racing Series national events, NHRA Lucas Oil Drag Racing Series divisional events, divisional NHRA Summit Racing Series Finals, and divisional National Open events. Driver numbers and class designation letters must be displayed on both side windows and the windshield. Numbers on side windows must be a minimum 4 inches high and 1 1/2 inches wide. Class designation letters must be a minimum 3 inches high and 1 inch wide. Numbers and class designation on windshield must be a minimum of 3 inches high and 1 inch wide. Driver's competition number and class designation must be displayed in a legible manner in a contrasting color to the vehicle's background color, or light color on windows, in a prominent position, and be clearly visible to the tower personnel. Class and numbers must be in the form of permanent decals or paint. The use of shoe polish in any form is prohibited.

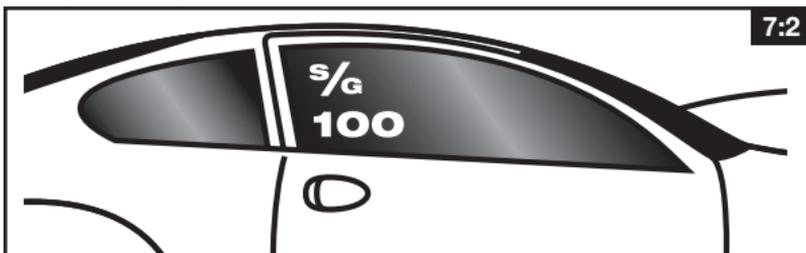

7:3 FENDERS

In Super Stock and Stock, the leading and trailing edges of fender openings may be trimmed for tire clearance, maximum 2 inches. All vehicles in all classes must have re-rolled or beaded edges on altered fenders. Flaring or spreading external fender lines prohibited, except as noted in Class Requirements. Front fenders may not be "drooped" on full-fendered car except as noted in Class Requirements.

7:4 FIREWALL

Each car in competition must be equipped with a minimum .032-inch aluminum or .024-inch steel firewall, extending from side to side of the body and from the top of the engine compartment's upper seal (hood, cowl, or deck) to the bottom of the floor and/or belly pan. Firewall must provide a bulkhead between the engine and/or fuel tank and driver compartment. All holes in firewall must be sealed with aluminum or steel. In certain instances, fiberglass, carbon fiber, or other composites may be used. See Class Requirements or consult NHRA. Use of magnesium prohibited.

7:5 FLOOR

All cars without floors must be equipped with floor pans made

of steel or aluminum that must extend the full length and width of the driver compartment to the rear of the driver's seat. Cars equipped with floors or belly pans made of fiberglass or other breakable material must have metal subfloors. In all cars with OEM fiberglass floors, a crossmember (minimum 2 inches x 2 inches, .083-inch wall thickness square tubing) must be installed between framersails for proper driver's seat, seat belt, shoulder harness, and crotch strap installation. Belly pans and subfloors enclosing engine or driver compartment must contain suitable drain holes so that liquids and foreign matter cannot collect, thus creating a fire hazard. Minimum .032-inch aluminum or .024-inch steel. In certain instances, an NHRA-accepted panel made of composite material may be substituted for steel or aluminum. Contact the NHRA Technical Department for list of accepted composite panels. Use of magnesium prohibited.

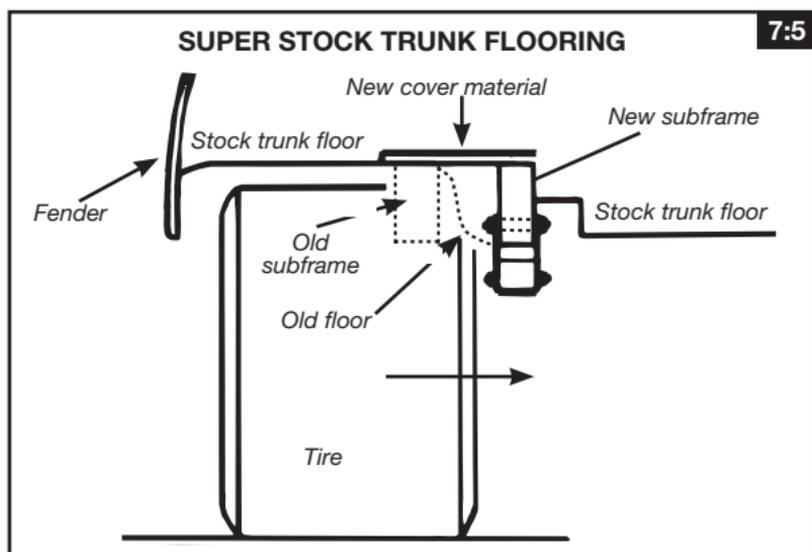

7:6 HOOD SCOOP

On full-bodied cars, where permitted, hood-scoop opening may not extend more than 11 inches above height of original hood surface as measured from the top of the opening directly down to the hood surface. On open-bodied, front-engine cars, scoop may not extend more than 11 inches above height of carburetor top. Scoop must have one opening only in Professional categories, and Top Alcohol Dragster, Pro Mod, Top Alcohol Funny Car, Comp, and Super Stock. All other classes, multiple scoop openings permitted. Sensors, transducers, vents, wiring, hoses, etc. prohibited inside hood scoop. See Class Requirements for additional restrictions.

7:7 WINDSCREEN

On open-bodied cars, or any other class car without a windshield, a metal or other fireproof deflector must be installed. Minimum size on Street Roadster and Altered class cars is 5 inches x 12 inches. The deflector should divert wind, liquids, and foreign matter over the driver's head, be securely mounted, and installed in such a manner that it does not obstruct the driver's frontal view in any way. Tape of any kind prohibited on any transparent windscreen. The use of any temporary or permanent shielding, including paint, that obstructs the driver's vision (e.g., blinders, staging aids) and that is attached to the helmet or windscreen is prohibited.

7:8 WINDSHIELD, WINDOWS

Windshields and/or windows on all cars, when called for under Class Requirements, must be of safety glass, Plexiglas, Lexan, or other shatterproof material, minimum 1/8-inch thick. Windshields may not be attached with self-locking fastener buttons. In all

Mello Yello Drag Racing Series and Lucas Oil Drag Racing Series vehicles, windshields and/or windows must be clear, without tinting or coloring, except factory-tinted safety glass. In all other applications, windshield/window tint must meet the applicable state requirements. Windshield/window must be in good condition and free from cracks. Competition number decals are permitted on any window, windshield or backlite, except as noted in Class Requirements. Tape of any kind prohibited on any windshield or window. The use of any temporary or permanent shielding, including paint, that obstructs the driver's vision (e.g., blinders, staging aids) and that is attached to the helmet, window or windshield is prohibited. Permitted shielding not to exceed 4 inches by 8 inches is permitted at this time provided that (a) it has a permanent attachment to the vehicle, such that it requires tools for removal, and (b) that the shielding is deemed safe by the driver in the driver's judgment and so long as the driver can demonstrate to technical inspectors that the purpose of the modification is to reduce distraction in the driver's field of vision. By using such a shield, the driver acknowledges and agrees that the driver deems such modification safe in the driver's judgment consistent with the driver's obligations in Section 1, Participant Agreements and Administrative and Procedural Rules, set forth above, and that the shield does not impair or interfere with the safe operation of the driver's vehicle. Tape, tie straps, binder clips, hook-and-loop fasteners, glue, etc. are prohibited for attachment purposes. Vehicle-mounted shielding is allowed to pivot as long as it remains permanently attached. See General Regulations 10:7.

ELECTRICAL/CONTROL: 8

8:1 BATTERIES

All batteries must be securely mounted; must be of sufficient capacity to start vehicle at any time. Batteries may not be relocated into the driver or passenger compartments. Rear firewall of .024-inch steel or .032-inch aluminum (including package tray) required when battery is relocated in trunk. In lieu of rear firewall, battery may be located in a sealed .024-inch steel, .032-inch aluminum, or NHRA-accepted poly box. If sealed box is used in lieu of rear firewall, box may not be used to secure battery and must be vented outside of body. Relocated battery(s) must be fastened to frame or frame structure with a minimum of two 3/8-inch-diameter bolts. OEM located batteries without complete OEM hold-down hardware must be secured to OEM battery box/tray using the same 3/8-inch-diameter bolt hold-down method described in previous sentence. ("J" hooks prohibited or must have open end welded shut.) Metal battery hold-down straps mandatory. Strapping tape prohibited. A maximum of two automobile batteries, or 150 pounds combined maximum weight (unless otherwise specified in Class Requirements), is permitted. Maximums may vary according to Class Requirements.

8:2 DELAY BOXES/DEVICES

Prohibited in Top Fuel, Funny Car, Pro Stock, Pro Stock Motorcycle, Top Alcohol Dragster, Top Alcohol Funny Car, Pro Mod, Comp, Super Stock, and Stock; permitted in all other categories (E.T. rules may vary by division; contact division office). A delay box or delay device is defined as any device (electronic, pneumatic, hydraulic, mechanical, etc.) built for the express purpose of creating a delay between the release of transbrake line-loc, or two-step button, or release of foot or hand brake, or release of clutch pedal/lever, or release of any other device and the resultant action of the vehicle, or as otherwise determined by NHRA.

In categories that prohibit delay devices: Changeable vehicle components, legal unto themselves (solenoids, throttle-linkage

components, hoses, springs, etc.), even though the removal and replacement of that component may affect the reaction time of the vehicle in relation to the driver action, is not considered a delay device. All switches, buttons, wiring, solenoids, etc. must be for normal automotive use; i.e., not intended to create a delay (adjustable or non-adjustable) between release of the button and the resultant action of the solenoid.

Discovery of a delay device, adjustable or non-adjustable, at any time following pre-event technical inspection will be grounds for immediate disqualification from the event, loss of all NHRA Mello Yello Drag Racing Series points for the season, and suspension from all NHRA Championship Drag Racing events for remainder of season. Additional penalties may be imposed at the discretion of NHRA.

Additional requirements for handicap start categories that prohibit delay devices: Wiring may consist of a single (i.e., "one" or "1") continuous wire from a power source to a switch (or button), and a single continuous wire from the switch to the transbrake or line-loc solenoid. One splice (no quick-disconnect) is permitted from the two-step to the solenoid (i.e., between the switch and the solenoid). All line-loc/transbrake wiring before and after the switch must be separate from any other wiring and fully visible. Computer wiring, sensors, relays, and the like may not be wired to the solenoid wiring.

In categories that permit a delay device: Prior to use, all delay boxes/devices manufactured after Jan. 1, 2003, must be NHRA-accepted. A current list of NHRA-accepted delay boxes is available on NHRARacer.com. See Class Requirements for number of boxes/devices permitted. Delay device may serve only to create a preset delay between release of transbrake, line-loc, etc. button and resultant action of vehicle. All wiring associated with the delay device, throttle stop, ignition system, automatic shifter, and electronic fuel injection must be fully visible, labeled, and traceable. Delay devices and components must be utilized in an unaltered manner consistent with the manufacturer's installation and instruction books unless otherwise approved. The use of any visual, audible, etc. indications that are transmitted to the driver in any form that provide on-track data are prohibited.

Discovery of a prohibited device at any time following pre-event technical inspection will be grounds for immediate disqualification from the event, loss of all NHRA Mello Yello Drag Racing Series points for the season, and suspension from all NHRA Championship Drag Racing events for remainder of season. Additional penalties may be imposed at the discretion of NHRA.

8:3 IGNITION

Each car in competition must have a positive-action on/off switch, capable of de-energizing the entire ignition system, in good working order, located within easy reach of the driver. "Momentary contact" switch prohibited. Magneto "kill button"-type switches are prohibited.

All ignition systems and/or components wiring harnesses and attachments must utilize those supplied by the ignition system manufacturer. The wiring harness must be used in an unaltered manner consistent with the manufacturer's installation and instruction books. All wiring associated with the ignition system must be fully visible, labeled, and traceable.

All removable or pin-type timing devices are prohibited. Two-steps or other rev limiters that are adjustable by thumbwheel, replaceable chips, and the like may not be within the driver's reach

and will preferably be located outside the driver compartment.

The use of any programmable multi-point rev limiter and/or a rate-of-acceleration rpm limiter, either by themselves (e.g., MSD 7561, MSD 7761) or integrated into the ignition system (e.g., MSD 7531), is prohibited in NHRA competition.

8:4 MASTER CUTOFF

Mandatory when battery is relocated, or as outlined in Class Requirements. An electrical power cutoff switch (one only) must be installed on the rearmost part of each vehicle and be easily accessible from outside the car body. This cutoff switch must be connected to the **positive** side of the electrical system and must stop all electrical functions including magneto ignition. The off position must be clearly indicated with the word "OFF." If switch is "push/pull" type, "push" must be the action for shutting off the electrical system, "pull" to turn it on. Any rods or cables used to activate the switch must be minimum 1/8-inch diameter. Plastic or keyed switches prohibited. Switches and/or controls must be located behind rear wheels on rear-engine dragsters.

8:5 STARTERS

All cars must be self-starting. Rollers and/or push starts prohibited.

8:6 TAILLIGHTS

All vehicles from E.T. up to and including Competition, one functional taillight mandatory. Strobe, flashing, high intensity, laser, infrared, photo sensitive, or other light-emitting/receiving device prohibited. See also Class Requirements.

8:7 SWITCHES & BUTTONS

Transbrake and/or line-loc switches must be NHRA-accepted for use in Comp, Super Stock, and Stock. A current list of NHRA-accepted transbrake buttons is available on NHRARacer.com. All switches and/or buttons must be standard, mechanical connection type. Infrared, laser, light source, or any other non-mechanical-type switch and/or button prohibited in all NHRA classes.

8:8 SHIFT LIGHT

Shift light may only be triggered by tachometer output or ignition output.

SUPPORT GROUP: 9

9:1 COMPUTER

A computer is defined as any device (electrical, mechanical, pneumatic, hydraulic, etc.) that activates any function of, or in any way affects the operation of, the vehicle based on measurement, sensing, processing, etc. of any data related to the performance of the vehicle. Except those installed on stock vehicles by the new-vehicle manufacturer for the proper operation of such vehicle, no vehicles may be equipped with computers. Per Class Requirements, OEM or aftermarket OEM-type electronic fuel injection permitted. Electronic fuel injection must be closed, OEM-type system; i.e., may monitor only engine functions. Monitoring of vehicle performance criteria, wheel speed, driveshaft speed, vehicle acceleration, etc. by fuel-injection system prohibited. Any form of torque management (e.g., launch control, traction control, height ignition correction, etc.) is prohibited. All related wiring, sensors, etc. must be identifiable to the tech inspector. See General Regulations 9:11 TRACTION CONTROL.

During NHRA competition, a portable computer (e.g., laptop, PDA, Palm Pilot, programmer, etc.) must be securely mounted when located in driver's compartment at any point beyond the staging area ready line. All functions or values must be preset prior to this point.

Per Class Requirements, timed or rpm-activated shifters and the like permitted, but all automated functions must be preset before the run. Timer may display only timer amount dialed in; analog or digital display permitted. Devices may be removed at any time at discretion of NHRA Technical Department.

9:2 DATA RECORDERS

Data recorders may be used (per Class Requirements) to record functions of a vehicle so long as they do not activate any function on the vehicle. All data recorders manufactured after Jan. 1, 2006, must be NHRA-accepted. A current list of NHRA-accepted data recorders is available on NHRARacer.com. Fifth-wheel sensing devices prohibited on all vehicles (includes wheelie-bar wheels). All lines sensing flow, pressure, etc. of fuel or oil must be metallic or steel braided. Ride height sensors prohibited unless specifically permitted by Class Requirements.

Any device (mechanical, hydraulic, pneumatic, electrical, optical, etc.) other than OEM-type that assists in determining track location of the competitor's own vehicle or opponent's vehicle is prohibited. Only OEM-style mirrors, mounted in conventional fashion, permitted.

For non-OEM data recorder applications, the transmission or display of any vehicle performance data (e.g., wheel speed, driveshaft speed, vehicle acceleration, etc.) gathered or processed by the data recorder, to the driver or any remote location, during the run, is prohibited. This data may be reviewed (printout, replay, etc.) only after the run. Discovery of a device that displays, indicates, or transmits "on track," "track location," or "elapsed time"-type data will be grounds for immediate disqualification from the event, loss of all NHRA Mello Yello Drag Racing Series or Lucas Oil Drag Racing Series points for the season, and suspension from all NHRA Championship Drag Racing events for remainder of season. Additional penalties may be imposed at the discretion of NHRA. Devices may be removed at any time at the discretion of the NHRA Technical Department.

9:3 FIRE EXTINGUISHER

An onboard fire extinguisher system is mandated under certain Class Requirements. Must be installed per manufacturer's specifications with all gauges clearly visible; viewing window(s) may be required for some applications. In other classes, it is recommended that each contestant and/or his or her crew have a loaded, serviceable fire extinguisher and a fire blanket in their possession, carried in the tow vehicle, race car, or otherwise available for immediate use. Dry chemical or CO₂-type extinguishers, 2 1/2-pound minimum size, are recommended. When installed in a race car, must be mounted in a secure manner; use of flip-open-type clamps prohibited.

When required, Top Fuel, Funny Car, Pro Stock, Top Alcohol Dragster, and Top Alcohol Funny Car, fire extinguishing system must meet SFI Spec 17.1 and installed and utilized per manufacturer's installation requirements. All front-engine, open-bodied supercharged or turbocharged (gasoline or methanol) cars running 7.49 seconds or quicker must be equipped with an SFI-rated 20-pound fire system.

For all other vehicles, onboard fire extinguisher systems must be manually controlled Cold Fire 302, Fire X plus, Halon FE1211 or 1301 or FM200, or F500, 3M Novec 1230 or DuPont FE-36 or FE-227, and mounted per manufacturer's specifications with the primary nozzle(s) directed in an attempt to protect the driver. Other agents, classified on the EPA SNAP list as Acceptable Total Flooding

Agents (Feasible for Use in Occupied Areas) and NHRA accepted, may be used. Bottles and lines must be mounted above the bottom of the adjacent framerails. Fire bottle activation cables must be installed inside framerail where cables pass engine/bellhousing area. Bottles must be DOT approved or meet SFI Spec 17.1 and permanently mounted (no hose clamps or tie wraps). In the case of more than one bottle, each bottle must have its own distribution tubing and nozzles. The use of bottles, nozzles, or tubing other than that recommended by the manufacturer is prohibited. Upon activation of the system, the contents of the bottle(s) must be totally discharged; partial-discharge systems prohibited. The bottles must be mounted in such a manner that should an explosion or failure of any mechanical component of the vehicle occur, the bottles will be protected from flying parts. When installed in/on a race car, must be mounted in a secure manner; use of flip-open-type clamps, hose clamps, tie wraps, snaps, etc. prohibited. They should be protected from excessive temperature and mounted rigidly to the vehicle. Remote cables must be metallic (plastic or plastic-wrapped cables prohibited) and installed so they are protected in the event of an upset or collision. Follow the manufacturer's recommendations regarding installation, especially on bend radius, and protection from crimping or kinking. All fire systems must use steel lines, steel or aluminum distribution nozzles, and must be equipped with a pressure gauge. **All bottles must be identified with a gross loaded weight figure.** It is the responsibility of the competitor to weigh the bottle prior to each event.

9:4 GENERATORS

All generators, air compressors, etc. that are powered by an internal combustion engine must have the exhaust directed up and above the top of the trailer, truck, RV, tent/awning, etc. and clear of other people's pits.

9:5 JACKS & JACKSTANDS

No work may be done under any car in the pit area while the car is supported by only one jack. Additional safety devices such as jackstands are mandatory to provide additional protection in the event of jack failure. Failure to observe this rule is grounds for immediate disqualification. Top Fuel, Funny Car, Pro Stock, Top Alcohol Dragster, and Top Alcohol Funny Car must use cradles/jackstand devices that attach to the frame (conventional jackstands prohibited) when working on and/or running engine in pits with vehicle in a raised position. Jackstand devices must be constructed as to provide a minimum ground clearance of 7 inches as measured from the ground to the outer diameter limit of the rear tires.

9:6 LIFTING DEVICES

Any form of mechanical, hydraulic, or other leverage-type device for raising a car's driving wheels off the starting-line surface is prohibited.

9:7 OVERSIZE TRAILERS

Contestants using lift-gate-type rear door must allow door to be open only during active unloading/loading. Further, contestants must take steps to prohibit anyone from passing underneath any part of the lift-gate-type door during the unloading/loading procedure. Also, all extended ramps must be stowed after use. Maximum width of trailer and awning combination not to exceed 22 feet.

9:8 PRESSURIZED BOTTLES

All pressurized bottles, excluding SFI Spec 17.1 Onboard Fire Extinguishing Systems (i.e., air, CO₂, nitrous, etc.), used for air shifters, clutches, etc. must meet, and be engraved as meeting, DOT-1800 pound minimum Spec. All bottles must be securely mounted (hose clamps and/or tie wraps prohibited). Any pressurized bottle used for pneumatic operation must be filled with

compressed air, nitrogen, or CO₂. All other materials prohibited.

9:9 PUSH BARS

Push bar must be designed to prevent push car from riding up on rear wheel of open-wheeled race cars. Push or tow starts prohibited.

9:10 TELEMETRY DEVICES

Telemetry transmission of certain Professional-category vehicle parameters intended for the sole purpose of national event television coverage, which meet applicable NHRA criteria, permitted. Application for telemetry transmission(s) must be submitted in writing to NHRA Technical Services, National Headquarters, Glendora, Calif. Final, written authorization from applicable event Technical Services Crew Chief mandatory. Discovery of any unauthorized telemetry device, or unauthorized transmission of data, in any category, will result in disqualification from the event, loss of all season points, plus suspension of competition privileges for the remainder of the season. Additional penalties may be imposed at the sole and absolute discretion of NHRA.

9:11 TRACTION CONTROL

Any type of traction-control device, electronic or mechanical, is prohibited. A traction-control device is any unit or system that uses live data to control functions of the vehicle, such as tire slip, which are not controlled by the driver. These devices are, but not limited to, timing control based on wheel, driveline, or engine acceleration, braking control, throttle control, tire-shake meters, vertical acceleration meters, misfire control, stutter box, relays, and/or rpm-activated chips. See 9:10 TELEMETRY DEVICES, 8:2 DELAY BOXES/DEVICES, 8:3 IGNITION, 9:1 COMPUTER.

9:12 TOW VEHICLE

Any vehicle used as a tow vehicle must have the driver's competition number displayed on the tow vehicle. Limit of six crewmembers in tow or push vehicle. Crewmembers must be inside cab or completely inside bed or truck, not to be seated on tailgate, standing on running boards, or otherwise not completely inside vehicle. Generators or other external power supplies, extension cords, support equipment other than the tow vehicle, etc. are prohibited outside the pit area. Once a race vehicle leaves the pit, it must be in race-ready condition, and the only support equipment permitted is the tow or push vehicle until the vehicle returns to the assigned pit area. (Exceptions for engine start-up equipment needed in Top Alcohol Funny Car, Top Alcohol Dragster, Pro Stock Bike, Funny Car, and Top Fuel.) Competitors in Super categories and Super Stock classes may use portable generators while stationary in the staging lanes.

9:13 TWO-WAY RADIO COMMUNICATION

The use of two-way radios for the purpose of voice communication between driver and crew is permitted in all classes. Telemetry may in no way be used for gathering data or performing control functions. When radio is mounted in driver's compartment, must be secured in holder by some type of strap or device when car is moving.

9:14 WARM-UPS

It is mandatory that a driver be seated in the car in the normal driving position anytime the engine is running, unless coupler or driveline is removed from vehicle. **The practice of transbrake testing, converter stalls, line-loc testing, and/or transmission warming is prohibited in all classes, in all areas of the event except in starting-line approach areas beyond staging, or unless vehicle is on jackstands. Non-compliance is grounds for disqualification or such other and/or action as deemed appropriate by NHRA.**

TOP FUEL & FUNNY CAR: When starting these categories of

vehicles in the pit area, the car must be fully within the assigned space. Race teams may not back car out of the pit space to start the engine. NO PART OF THE REAR TIRE MAY EXTEND PAST THE END OF the assigned pit space. When occupying the “end spot” pit space or if the neighboring trailer does not completely shield your car, it is mandatory to park a tow truck/ car alongside the race car while the engine is running.

9:15 CAMERAS

Images from any camera permitted under this section are permitted to be used for competition/analytical purposes only. One camera permitted unless NHRA permission is granted for additional cameras. May not be intentionally directed at the racer in the other lane without NHRA permission. Video may not be transmitted in any means or manner without NHRA permission, which permission, if granted, may be revoked at any time. Incident video may not be transmitted under any circumstances. No video monitors permitted in or on the car. Video may not be used in any way to determine track position in real time. Must be securely attached to the vehicle with appropriate fasteners. May not be attached with suction cups, wire ties, hose clamps etc. For any camera mounted external to any vehicle, all mounting brackets, associated fasteners, hardware, etc. from the camera to the vehicle attachment point must be metal, no plastic or nonmetallic components permitted. For all vehicles, attachment to the driver, the driver’s helmet, or the steering wheel/handle bars prohibited.

DRIVER: 10

10:1 APPAREL

Each member of a participant crew must be fully attired when present in the staging, starting, and competition areas of the racetrack. Shoes are mandatory. Shorts, bare legs, tank tops, or bare torsos are prohibited when driving in any class. See Class Requirements.

10:2 APPEARANCE

Vehicles participating in drag racing events must be presentable in appearance at all times; those considered improperly prepared may be rejected by the technical inspector. The appearance of personnel attending contestant vehicles is equally important and is subject to the same considerations.

10:3 ARM RESTRAINTS

Where mandated by Class Requirements, arm restraints must be worn and adjusted in such a manner that driver’s hands and/or arms cannot be extended outside of roll cage and/or frame rails. Arm restraints shall be combined with the driver restraint system such that the arm restraints are released with the driver restraints. Refer to manufacturer for instructions.

10:4 CREDENTIALS

Each driver of a vehicle entered in any event conducted at an NHRA member track must be at least 16 years of age (except Jr Dragster or Jr Street) and have either a valid state or government issued driver’s license beyond a learner’s-permit level or NHRA Competition License subject to inspection by officials at any time. In addition, a current NHRA license is required for participation in any divisional or national NHRA-sanctioned event.

All competitors at NHRA Mello Yello national events must be a minimum of 18 years of age. A 17-year-old may apply for a Professional-category license and national event entry if all the following criteria are met: 1) applicant’s 18th birthday falls during the regular NHRA national event schedule; 2) applicant was an active participant in another NHRA license category (9.99 E.T. or quicker) the previous year; 3) applicant holds a valid NHRA competition license (9.99 E.T. or quicker).

PROFESSIONAL

	Type A	Type B	Type C	Type D
LEVEL 1	TF	FC	PS	PSM
PRO SPORTSMAN				
LEVEL 2	TAD, NTF	TAFC, NFC	PM	TFH, PFH
LEVEL 3	COMP, TD, Adv. ET	COMP, TD, TS, Adv. ET	HU	Adv. ETM
LEVEL 4	SC	SC, SG, SST, SS, STK		
LEVEL 5		SST, SS, STK		
SPORTSMAN				
LEVEL 6	ET	ET, HU		ETM, SM, ATV
LEVEL 7	ET	ET, HU		ETM, SM, ATV

All license applicants must complete two runs at or above the requested class(es)' minimum e.t. and mph standard. The class standards are:

Class	Standard
Top Fuel	Two quarter-mile runs of 5.20 or quicker and two runs of 260 mph or faster OR two 1,000-foot runs of 4.50 or quicker and 240 mph or faster
Funny Car	Two quarter-mile runs of 5.50 or quicker and two runs of 250 mph or faster OR two 1,000-foot runs of 4.70 or quicker and 230 mph or faster
Pro Stock	Two quarter-mile runs of 7.40 or quicker and 175 mph or faster
Pro Stock Motorcycle	Two quarter-mile runs of 7.90 or quicker and two runs of 165 mph or faster
TAD/TAFC	Two quarter-mile runs of 6.20 or quicker and two runs of 205 mph or faster
Pro Mod	Two quarter-mile runs of 6.90 or quicker and two runs of 190 mph or faster
NTF/NFC/SPF	Two quarter-mile runs of 6.99 or quicker
TFH	Two quarter-mile runs of 7.50 or quicker
PFH	Two quarter-mile runs of 8.30 or quicker
Comp	Two quarter-mile runs representative of Comp class
TD/TS	Two quarter-mile runs of 7.99 or quicker
Levels 4 and 6	Two quarter-mile runs of 9.99 or quicker OR 135 mph or faster

All Level 1-3 license applicants are required to have a completed and approved physical examination prior to making any test runs. Physical forms and license applications are available at NHRARacer.com. (License and physical will expire two years from end of the month of exam date.) Likewise, the vehicle used for test runs must be current with respect to rules and regulations for the class/license being applied for.

To obtain a new permanent competition license or renew a license, please visit NHRARacer.com for the applications.

WHEEL-DRIVEN CATEGORIES

A new driver who has not previously held a competition license will be given a special cockpit-orientation (blindfold) test, and will be required to make a minimum of six runs under the observation of two licensed drivers and a designated NHRA official. Witnessing drivers must hold a competition license equal to or greater than one being applied for. A driver who is upgrading or crossgrading (bodied category to/from open-wheel category) is required to take the cockpit-orientation test and make three runs (per license application instructions). A licensed

driver may drive a car classed under his or her license limitation. It is prohibited to cross over to or from the long wheelbase category to short wheelbase, dragster to bodied, motorcycle to car, etc. unless specifically licensed for each.

JET EXHIBITION CATEGORIES

New driver must notify NHRA of intention to obtain a license and receive all required forms and rules for the category. Applicant must be minimum 18 years of age. All new drivers will pay a \$200 application fee with the submission of a physical-exam form. Proof of car must be submitted and inspection must be performed prior to NHRA issuing a permit, which will include NHRA membership and insurance, to begin initial licensing runs.

New driver, or driver cross grading from Funny Car to dragsters, etc. will be given a cockpit-orientation (blindfold) test. New driver must make a minimum of 12 test runs over a two-day (minimum) period. Blindfold test and test runs must be witnessed by two currently licensed jet exhibition drivers with at least three years' experience, a track official, and an NHRA-designated person. Test runs are typically divided into three sessions, as follows:

Session 1: Three half passes, one moderate pass.

Session 2: Four moderate passes.

Session 3: One moderate pass, three full passes.

Driver crossgrading from one jet exhibition category to another must complete a blindfold test and minimum three full test runs in front of standard witnesses. (A driver with an NHRA competition license in any wheel-driven category may not crossgrade to a jet exhibition license, regardless of experience.)

In all categories, competition license will be granted or denied in NHRA's discretion.

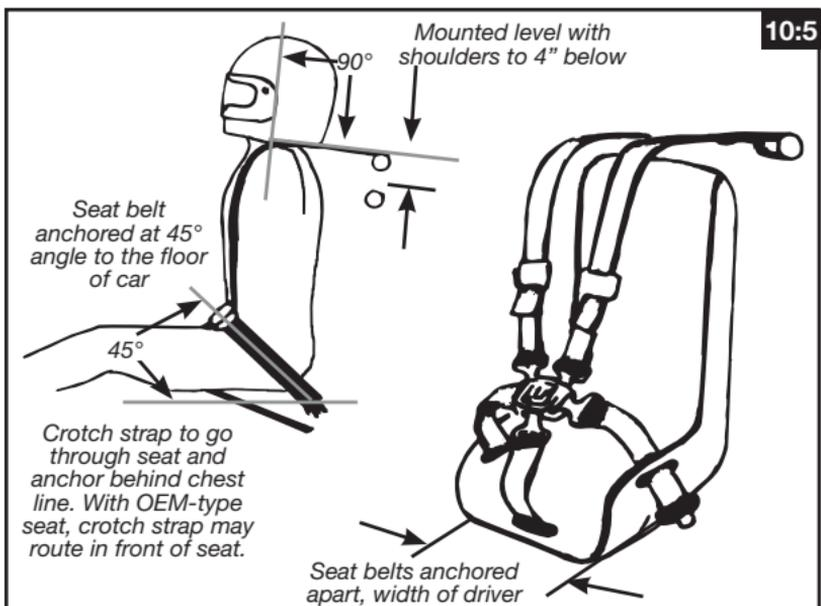

10:5 DRIVER RESTRAINT SYSTEMS

A quick-release driver restraint system meeting SFI Spec 16.1 or SFI Spec 16.5 is mandatory in all cars in competition required by the rules to have a roll bar or a roll cage. (Permitted in all other classes.) Driver restraint system must be clearly labeled as meeting SFI Spec 16.1 or SFI Spec 16.5 and be dated by manufacturer. SFI 16.1 or 16.5 3-inch-wide shoulder harness straps folded over and sewn to be 2 inches wide by the original manufacturer in order to fit into head and neck restraint lips/channels are acceptable. See Class Requirements for

additional requirements for Top Fuel and Funny Car. SFI Spec 16.1 or 16.5 Y-type belts prohibited. (In cases where the class does not require an SFI 16.1 or 16.5 driver restraint system, the two-year recertification does not apply.) System must be updated at two-year intervals from date of manufacture. All seat-belt and shoulder harness hardware must be originally designed to be used with each other and produced by the same manufacturer. For harness installation, see illustration. Cars using OEM or OEM-type seat may route crotch strap in front of seat instead of through seat; otherwise, install according to manufacturer's instructions. Mandatory that units must release all attachment points (five, six or seven, if applicable) in one action. When arm restraints are worn with a restraint system that utilizes a "latch lever," a protective cover must be installed to prevent arm restraint from accidentally releasing the latch lever. Protective cover not required if system utilizes "duck-bill" latch hardware. All harness sections must be mounted to the frame, crossmember, or reinforced mounting, and installed to limit driver's body travel both upward and forward. Seat belts may not be wrapped around lower frameroils. Under no circumstances are bolts inserted through belt webbing permitted for mounting.

10:6 HEAD PROTECTOR

In any car where a roll bar or roll cage is installed, a padded head protector must be provided at the back of the driver's head and constructed in an attempt to prevent whiplash upon impact. The roll bar or cage must be padded wherever it may come in contact with the driver's helmet. Adequate padding should permit minimum 1/4-inch compression or meet SFI Spec 45.1. The use of weather stripping and similar thin or low impact resisting materials is prohibited. A padded roll bar or cage alone is not acceptable as a padded head protector unless it is within 4 inches of the driver's helmet. A seat that incorporates a reinforced head rest is permitted.

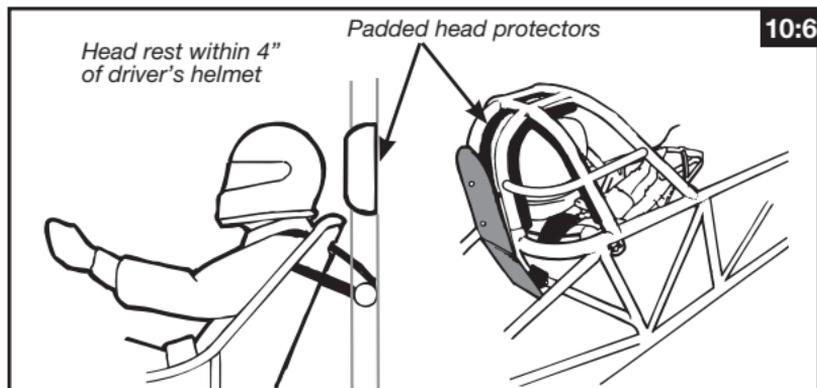

10:7 HELMET

As outlined under Class Requirements, drivers in all classes, including motorcycles, must wear a helmet meeting Snell or SFI Specifications.

Full-face helmet mandatory on all cars 9.99 or quicker. See individual Class Requirements for additional requirements. Shield mandatory 7.49 and quicker.

Drivers of NHRA Lucas Oil Drag Racing Series and E.T. cars (13.99 or quicker) must use a helmet meeting Snell K2015, SA2010, SAH2010, K2010, M2010, SA2015, M2015, or SFI 31.1/2010, 31.1/2015, 41.1/2010, or 41.1/2015 Specs. Drivers in supercharged, front-engine, open-bodied cars and Funny Cars must wear a helmet meeting Snell SA2010, SA2015, SAH2010, or SFI 31.1/2010, 31.1/2015 Specs. See Class Requirements.

NHRA Helmet Expiration Dates

Label	Expires	Label	Expires
Snell 2010	1/1/2022	SFI 24.1/2010 (JDRL only)	1/1/2022
Snell 2015	1/1/2027	SFI 24.1/2015 (JDRL only)	1/1/2027
SFI 31.1 and 41.1/2010	1/1/2022	Snell CMR 2007 (JDRL only)	1/1/2019
SFI 31.1 and 41.1/2015	1/1/2027	Snell CMS 2007 (JDRL only)	1/1/2019

Structural modifications to helmet/shield are prohibited. Cutting of helmet or helmet shield prohibited. Helmet must remain as manufactured, except for paint scheme/graphics and permitted non-structural driver modifications to helmet shield as set forth below. Taping or similar modifications to the helmet shield made by the driver that reduce the driver's field of vision, and are deemed safe by driver in the driver's judgment, are permitted at this time so long as the driver can demonstrate to technical inspectors that the purpose of the modification is to reduce distraction in the driver's field of vision. By using such a modification to the helmet shield, the driver acknowledges and agrees that the driver deems such modification safe in the driver's judgment consistent with the driver's obligations in Section 1, Participant Agreements and Administrative and Procedural Rules, set forth above, and that the modification does not impair or interfere with the safe operation of the driver's vehicle. See General Regulations 7:8.

10:8 NECK COLLAR/HEAD AND NECK RESTRAINT DEVICE/SYSTEM

Neck collar must be commercially produced and designed for racing. Two different types of collars are commercially available: a full 360-degree "donut" type or a pull-together "horseshoe" type. Modification according to manufacturer's recommendations to fit helmet and driver's neck/shoulder spacing permitted. Must be worn as per manufacturer's recommendations. Must meet SFI Spec 3.3 as per class rules.

Neck collar meeting SFI Spec 3.3 mandatory in all open-bodied cars and any car running 9.99 (*6.39) or quicker or cars exceeding 135 mph. A head and neck restraint device/system may be used in lieu of a neck collar.

A head and neck restraint device/system meeting SFI 38.1 is mandatory for any vehicle running 200 mph or faster or running 7.49 (*4.49) or quicker or by Class Requirements.

When using a head and neck restraint device/system, at all times that the driver is in the race vehicle, from the ready line until the vehicle is on the return road, driver must properly utilize the SFI-approved head and neck restraint device/system, including connecting the helmet as required for full functionality of the device. The device/system must meet SFI Spec 38.1 and must display a valid SFI label. The head and neck restraint device/system, when connected, must conform to the manufacturer's mounting instructions, and it must be configured, maintained, and used in accordance with the manufacturer's instructions.

A head and neck restraint device/system may be used with or without a neck collar.

10:9 OCCUPANTS

No more than one person is permitted in any car during any run,

except one co-driver permitted in 14-second (*8.60) and slower E.T. cars; co-driver must be a minimum of 16 years old. All occupants of tow vehicles must be inside of car or pickup in a seated position while tow vehicle is in operation. Anytime a car is started, whether in the pits, staging lanes, with self-starter, or anywhere else on the race facility, a competent driver must be in the driver's seat unless coupler or driveline is removed. Non-compliance is grounds for disqualification from the event.

10:10 PROTECTIVE CLOTHING

"Protective Clothing" includes suit (one-piece suit or jacket and pants); head sock; gloves; and boots or shoes.

Driver must meet all Protective Clothing requirements stated under Class Requirements for vehicle being driven.

SEE CLASS REQUIREMENTS.

Protective Clothing requirements stated are minimum requirements; drivers are free to upgrade Protective Clothing.

Each item of Protective Clothing must meet applicable specifications. Each item must be properly labeled and in good condition. All jackets/pants or suits for SFI Spec 3.2A/15 or 3.2A/20 must be recertified on a five-year interval.

All gloves must have a full layer of flame-retardant material inside the glove. Leather palm gloves without a full layer of flame-retardant material separating leather from driver's hand prohibited.

An SFI 3.3 head sock or SFI 3.3 skirted helmet is required where a neck collar is required but has been substituted with a head and neck restraint device. See Class Requirements.

If no specific Protective Clothing requirements are stated for a particular class, then the minimum requirements are as follows: full-length pants; short- or long-sleeved shirt; closed shoes; and socks. No shorts. No bare legs. No bare torsos. No tank tops. No open-toe or open-heel shoes or sandals. Synthetic clothing not recommended. For unaltered full-bodied OEM vehicles with an unaltered fuel system using ethanol or methanol and unleaded gasoline fuel blends such as E-85 or gasohol the Protective Clothing requirements are the same as those for gasoline. See Class Requirements.

For any vehicle other than an unaltered full-bodied OEM vehicle with an unaltered fuel system using ethanol or methanol fuel blends in excess of 15% by volume such as E-85, requires the same protective clothing as is required for 100% alcohol and/or methanol fueled cars. For ethanol or methanol fuel blends of 15% or less the Protective Clothing requirements are the same as those for gasoline. See Class Requirements.

10:11 SEAT BELTS

All cars not required by Class Requirements to use SFI 16.1 driver restraint systems must be equipped with an accepted quick-release-type driver seat belt. Belts must be securely fastened to the frame, crossmember, or reinforced mounting so that all fittings are in a direct line with the direction of pull. Seat belts may not be wrapped around lower frameroils. Steel castings of the type recommended by FAA or U-bolt-type mounts are permitted. If used for installation, flat steel plates must be a minimum of 1/4-inch thickness and have rounded edges to prevent cutting seat belts. Under no circumstances can belts be installed with bolts through webbing. In all cars

with fiberglass floors, a crossmember (minimum 2-inch x 2-inch x .083-inch wall thickness square tubing) must be installed between frameroils for proper driver's seat-belt installation.

GENERAL: 11

11:1 ADVERTISING AND OTHER MATERIAL/DISPLAYS

NHRA reserves the right to regulate any advertising or other material that is present on site at any NHRA event including without limitation any material appearing on any participant, on the body or any other visible part of any vehicle or transporter participating in NHRA events including on support vehicles, in any pit area, in any area of the dragstrip from the staging lanes to the end of the dragstrip, and any item or material on site that may constitute a product placement. Participants and vehicles may be excluded from competition and from event facilities if, in NHRA's discretion, any advertising or other material displayed on a person, race or support vehicle, or in a pit area or otherwise is not in the best interests of NHRA and the sport of drag racing, and/or is or may be in conflict with any applicable law.

Moreover, NHRA will require compliance with all guidelines and requirements of any telecaster for events that will be telecast. In addition, NHRA may require certain indicia to be visible on a vehicle as a condition of participation in competition if NHRA determines that such requirement is in the best interests of NHRA and the sport of drag racing.

By way of illustration and without limitation, online gambling is an activity deemed by NHRA to be not in the best interests of NHRA and the sport of drag racing, and an activity that NHRA will not allow to be displayed or advertised on site at any NHRA event or in connection with NHRA in any manner whatsoever. Websites that allow gaming that is entirely free and for fun may be permitted pursuant to further guidelines that may be requested from NHRA. Violation of any part of any such guideline will be treated as violation of the NHRA Rulebook.

SFI SPECIFICATIONS

Following is a list of all SFI Specifications applicable to NHRA Championship Drag Racing, with respective expiration periods. An item with an expiration period must be returned to the original manufacturer for inspection and recertification at the end of this period before it can be permitted for further use at an NHRA event. Unless otherwise noted in this Rulebook, refer to SFI Foundation.com for the latest version of all non-chassis specifications. Also, unless otherwise noted in this document, refer to TechConn.NHRA.com for the latest SFI chassis specification versions. Note: Only certified NHRA chassis inspectors and authorized NHRA officials have access to TechConn.NHRA.com.

SFI SPEC	DESCRIPTION	EXPIRATION PERIOD
1.1	Single-Disc Clutch & Flywheel Assembly	2 years
1.2	Multi-Disc Clutch & Flywheel Assembly E.T. through Comp, PS	2 years
1.3	Multi-Disc Clutch and Flywheel Assembly TAD, TAFC, TF, and FC	1 year
1.4	Multi-Disc Clutch and Flywheel Assembly TAD and TAFC.	1 year
1.5	Multi-Disc Clutch Assembly (with Power Adders).	1 year
2.1	Rear-Engine Dragster Chassis Spec, TAD (Includes Wing and Rear-End Mounting)	1 year
2.2	Front-Engine Dragster Chassis Spec, NTF, TAD	1 year
2.3	Rear-Engine Dragster Chassis Spec, TF (Includes Wing and Rear-End Mounting)	1 year
2.4	Front-Engine Dragster Chassis Spec, Advanced E.T., A/D, B/D, C/D, A/ED, B/ED, A/ND, & B/ND	3 years
2.5	Rear-Engine Dragster Chassis Spec, Adv. E.T. A/D, B/D, C/D, D/D, A/ED, B/ED, C/ED, & D/ED (Does Not Include Wing or Rear-End Mounting)	3 years
2.6	Front-Engine Dragster Chassis Spec, 7.50 and Slower	3 years
2.7	Rear-Engine Dragster Chassis Spec, 7.50 and Slower	3 years
3.2A/1	Jacket (and Pants Where Applicable)	
3.2A/5	Jacket (and Pants Where Applicable)	
3.2A/15	Jacket and Pants or Suit	5 years, including the year on the tag
3.2A/20	Driver's Suit	5 years, including the year on the tag
3.2A/25	Driver's Suit	5 years, including the year on the tag
3.2A/30	Driver's Suit	5 years, including the year on the tag
3.3	Neck Collar and Head Sock	
3.3/1	Gloves, Shoes	
3.3/10	Helmet Skirt, Gloves	
3.3/5	Gloves, Shoes, Boots	
3.3/15	Gloves, Boots	
3.3/20	Gloves, Boots	
4.1	Automatic Transmission Shield, Rigid	5 years
4.1	Automatic Transmission Shield, Flexible	2 years
6.1	Flywheel Shield, Spec 1.1 & 1.2 (2-Disc Max, or 3-Disc, 8-Inch Dia. Max)	5 years
6.2	Flywheel Shield, Spec 1.2, 1.3, 1.4 & 1.5 Clutch (Check with Manufacturer; May Be Only 1 Year)	2 years
6.3	Flywheel Shield, Spec 1.2, 1.3 & 1.4 Clutch (Check with Manufacturer; May Be Only 1 Year)	2 years

SFI SPEC	DESCRIPTION	EXPIRATION PERIOD
7.1	Lower Engine Ballistic/Restraint Device	1 year
7.2	Lower Engine Ballistic/Restraint Device	5 years
10.1	Altered & F/E Dragster Chassis Spec, TAFC	1 year
10.2	Altered Chassis Spec, 6.00 to 7.49	3 years
	Adv. E.T., AA/A, BB/A, AA/AT, BB/AT, A/A, B/A	3 years
10.3	Altered Chassis Spec, 7.50 and slower	3 years
10.4	Side-Steer Roadster Chassis Spec., 9.99 and quicker . . .	3 years
10.5	Funny Car Chassis Spec, FC	1 year
14.1	Supercharger Restraint (Roots)	2 years
14.2	Supercharger Restraint (Roots)	2 years
14.2.1	Supercharger Restraint (Screw-Type)	2 years
14.3	Supercharger Restraint (Top Fuel)	2 years
14.4	Valve Cover Restraint	2 years
14.5	Manifold Blankets	2 years
15.1	Rear-Drive Wheels, TAD, TAFC, Pro Mod, PS	
15.2	Front Wheels	
15.3	Rear-Drive Wheels, TF and FC	2 years
15.4	Rear-Drive Wheels, TF and FC	1 year
16.1	2- or 3-Inch Driver Restraint System	2 years
16.5	2- or 3-Inch Driver Restraint System	2 years
17.1	Onboard Fire Extinguishing Systems	2 years
18.1	Harmonic Balancer	
23.1	Manifold Burst Panel	
24.1/2010	Youth Full-Face Helmet (for JDRL only)	exp. 1/1/2022
24.1/2015	Youth Full-Face Helmet (for JDRL only)	exp. 1/1/2027
25.1	SFI Full Body Chassis Spec, Pro Stock	1 year
	Adv. E.T.	3 years
25.2	SFI Full Body Chassis Spec, 3,200-Pound Maximum	3 years
25.3	Full-Bodied Car, Tube Chassis Roll Cage 6.50-7.49, 3,600-Pound Maximum	3 years
25.4	Full-Bodied Car, Tube Chassis Roll Cage 7.50-8.49, 3,600-Pound Maximum	3 years
25.5	Full-Bodied Car, with OEM Frame 7.50-8.49, 3,600-Pound Maximum	3 years
27.1	Window Net	2 years
28.1	Fuel Cell: Pro Stock, Pro Modified, Advanced E.T.	
29.1	Automatic Transmission Flexplate	3 years
30.1	Automatic Transmission Flexplate Shield	5 years
31.1/2010	Full-Face Helmet	exp. 1/1/2022
31.1/2015	Full-Face Helmet	exp. 1/1/2027
34.1	Supercharger, Screw-Type	3 years
38.1	Head and Neck Restraint System	5 years
40.1/1, 40.1/2	Motorcycle Rider's Suit	
41.1/2010	Open-Face Helmet	exp. 1/1/2022
41.1/2015	Open-Face Helmet	exp. 1/1/2027
42.1	Steering-Wheel Hub	
43.1	Driveshaft	
45.1	Roll-Bar/Cage Padding	
49.1	Top Fuel Rear Wing Assembly	1 year
49.2	Top Fuel Front Wing Assembly	1 year
54.1	Nonflammable, Thermal Barrier/Fire Extinguishing Coatings	

Item	6.00 to 7.49	7.50 to 9.99	10.00 to 10.99	11.00 to 11.49	11.50 to 13.99	14.00 & Slower	Expiration
Master Electrical Cutoff Switch	Y	Y	8:4 / 135 mph	8:4	8:4	8:4	
Neck Collar (SFI 3.3)	Y	Y	10:8	10:8	10:8	10:8	
NHRA Competition License	Y	Y	10:4	10:4	10:4	10:4	
NHRA Chassis Sticker	Y	Y	4:4	4:4	4:4	4:4	
Padding Roll Bar/Cage	Y / SFI	Y / SFI	Y / SFI	Y	10:6 / 135 mph	10:6 / 135 mph	
Parachute	Y	Y / 150 mph	4:8	4:8	4:8	4:8	
Pressurized Bottles DOT (1800)	Y	Y	Y	Y	Y	Y	
Protective Clothing SFI 3.2A/1.5; 3.2A/2.0; 3.2A/2.5; 3.2A/3.0 Driver's Suit	Y	Y	Y	Y	10:10	10:10	5 years, incl. year on tag
Roll Bar			Y	Y	C / 13.49	4:10	
Roll Cage	Y	Y	Y / 135 mph	4:11	4:11	4:11	
SFI Chassis Specification SFI 2.1; 2.2; 2.3; 10.1; 10.5; 25.1 Full Body Chassis Spec; Pro Stock SFI 2.4; 2.5; 2.6; 2.7; 10.2; 10.3; 10.4; 25.1 Adv. E.T.; 25.2; 25.3; 25.4; 25.5	Y	4:4 / 180 mph	4:4	4:4	4:4	4:4	4:4
Supercharger Restraints (SFI 14.1; 14.2; 14.21; 14.3)	Y	1:11	1:11	1:11	1:11	1:11	3 years 1 year
Taillight	Y	Y	Y	Y	Y	Y	
Transmission Flexplate (SFI 29.1)	Y	Y	2:14	2:14	2:14	2:14	3 years
Transmission Locking-Type Dipstick	Y	Y	Y	Y			
Transmission Reverse Lockout	Y	Y	Y	Y	Y	Y	
Transmission Shield (SFI 4.1)	Y	Y	Y	2:14	2:14	2:14	Rigid, 5 yrs.; Flexible, 2 yrs.
Window Net Full-Bodied Cars	Y	Y	6:3 / 10:3	6:3 / 10:3	6:3 / 10:3	6:3 / 10:3	

Thank you for being an NHRA Member. It is always our privilege to serve you. To renew or join, visit NHRAFacer.com.

2019 NHRA E.T. QUICK REFERENCE CHART & SFI EXPIRATIONS

Y = Required • C = Convertibles • Numbers Refer to General Regulations • Years Refer to SFI Expirations • In no way is this Quick Reference Chart intended to supersede or replace the current NHRA Rulebook (quarter-mile e.t.s) Unless otherwise noted in this E.T. Quick Reference Chart, refer to SFI Foundation.com for the latest version of all non-chassis specifications. Also, unless otherwise noted in this document, refer to TechComm.NHRA.com for the latest SFI chassis specification versions. Note: Only certified NHRA chassis inspectors and authorized NHRA officials have access to TechComm.NHRA.com. An item with an expiration period must be returned to the original manufacturer for inspection and recertification at the end of this period before it can be permitted for further use at an NHRA event.

Item	6.00 to 7.49	7.50 to 9.99	10.00 to 10.99	11.00 to 11.49	11.50 to 13.99	14.00 & Slower	Expiration
Aftermarket Rear Axles	Y	Y	Y	2:11	2:11	2:11	
Arm Restraints (Open-Bodyed Cars)	Y	Y	Y	Y	10:3 / 11.99	10:3	
Bellhousing (SFI 6.1; 6.2)	Y	Y	Y	Y	2:10	2:10	
Driver Restraint System (SFI 16.1; 16.5)	Y	Y	Y / 10:5	Y / 10:5	C / 10:5	10:5 / 10:11	2 years
Driveshaft Loop	Y	Y	Y	Y	2:4	2:4	
Electric Vehicle 16.00 & Quicker	Y	Y	Y	Y	Y	2:4	
Flexplate Shield (SFI 30.1)	Y	Y	2:14	2:14	2:14	2:14	5 years
Flywheel/Clutch (SFI 1.1; 1.2)	Y	Y	Y	Y	2:5	2:5	2 years
SFI 1.1: Single-Disc Clutch & Flywheel Assembly, 1.2: Multi-Disc Clutch & Flywheel Assembly E.T. through Comp, PS							
Flywheel Shield (SFI 6.1; 6.2; 6.3; 9.1)	Y	Y	Y	Y	2:10	2:10	
SFI 6.1: Flywheel Shield, Spec 1.1 & 1.2 (2-Disc Max. or 3-Disc, 8-inch Diameter Max.)							5 years
SFI 6.2: Flywheel Shield, Spec 1.2, 1.3, 1.4 & 1.5 Clutch (Check with Manufacturer; May Be Only 1 Year)							2 years
Harmonic Balancer (SFI 18.1)	Y	Y	Y	Permitted	Permitted	Permitted	
Head & Neck Restraint Device/System (SFI 36.1)	Y	10:8 / 200 mph	10:8	10:8	10:8	10:8	5 years
Helmet	Y	Y	Y	Y	Y	10:7	
SFI 24.1/2010; 31.1/2010; 41.1/2010; Snell 2010							exp. 1/1/2022
SFI 24.1/2015; 31.1/2015; 41.1/2015; Snell 2015							exp. 1/1/2027
Liquid Overflow	Y	Y	Y	Y	Y	Y	

Handy Charts and Formulas

- **Cubic Inch Displacement**
CID = bore x bore x stroke x 0.7854 x number of cylinders
- **Horsepower** = (RPM x torque)/5,252
- **Torque** = (5,252 x HP)/RPM
- **Valve Area** = valve diameter x valve diameter x .7854
- **Rod Ratio** = rod length/crank stroke length
- **Average Piston Speed** = crank stroke x RPM/6
- **Rear Gear Ratio** = (RPM at finish line x tire diameter)/(MPH x 336)
- **Volume (cc's) of deck clearance**
= bore x bore x 12.87 x depth of deck clearance
- **Volume (cc's) of head gasket**
= bore x bore x 12.87 x thickness of head gasket

$$\text{Compression Ratio} = \frac{\text{comb chamber cc's} + \text{gasket cc's} + \text{deck CI cc's} + (\text{displacement} \times *2.0483)}{\text{comb chamber cc's} + \text{gasket cc's} + \text{deck CI cc's}}$$

* 2.0483 for 8-cyl. * 2.7311 for 6-cyl. * 4.0967 for 4-cyl.

- **Circumference** = $\pi \times \text{diameter}$
- **Area of circle** = $\pi \times \text{radius}^2$
- **Volume of cylinder** = $\pi \times \text{radius}^2 \times \text{height}$
 $\pi = pi \quad \pi = 3.1416 \quad \text{radius}^2 = \text{radius} \times \text{radius}$

Weights:

Oil	1 gallon = 7.0 pounds	1 quart = 1.75 pounds
Gas	1 gallon = 6.2 pounds	1 quart = 1.55 pounds
Water	1 gallon = 8.4 pounds	1 quart = 2.10 pounds

Metric and Standard Conversion

The metric system is a decimal system of measurements used in scientific work for measuring length, weight, and volume. These basic units are modified with prefixes to express the units as larger or smaller quantities. Some of the common prefixes are:

Kilo: one thousand (1000)

Deci: one-tenth (0.1)

Centi: one-hundredth (0.01)

Milli: one-thousandth (0.001)

Micro: one-millionth (0.000001)

Length

1 kilometer (km) = 1,000 meters = 3,280.83 feet = .6215 mile

1 meter (m) = 100 centimeters = 39.37 inches = 1.09 yards

1 decimeter (dm) = 3.937 inches

1 centimeter (cm) = .3937-inch

1 mile = 1.609 kilometers

1 inch = 2.54 centimeters

1 yard = .91 meters

1 inch = 25.4 millimeters

Mass

1 kilogram (kg) = 1,000 grams (g) = 2.2045855 pounds

1 pound = 453.6 grams

1 ounce = 28.35 grams

1 gram = 1,000mg

kilograms x 2.20 = pounds

pounds / 2.20 = kilos

Volume

1 liter (l) = 1,000 cubic centimeters (cc) = 61.025 cubic inches

1 cubic inch = 16.387 cubic centimeters

MAHLE

Motorsport



MAHLE MOTORSPORTS.
**INDUSTRY
LEADER
IN PISTON TECHNOLOGY**

Every MAHLE Motorsport piston is backed by 95+ years of racing heritage and technology innovation. We employ the most advanced piston design and machining processes being used today, many of which are performed on machinery MAHLE manufactures themselves specifically for piston production. MAHLE's light-weight, low-drag, ultra-strong slipper skirt forging designs truly out perform the competition. Features include profiled pin bores, advanced dual and triple ovality skirt profiles and tighter tolerances with unmatched consistency. All MAHLE Motorsport pistons include application specific surface treatments, like the proprietary Grafal® anti-friction skirt coating, hard anodized top ring grooves to eliminate micro welding and a phosphate coating to protect pin bores from galling. These are just a few of the reasons why top professional race teams use MAHLE Motorsports pistons. Rely on the technology leader MAHLE Motorsports, to give you the winning advantage. www.mahlemotorsports.com 1-888-255-1942



Unbeatable Value! **Summit**[®] RACING EQUIPMENT

- The best selection • Trusted tech • World-famous service
- Fast shipping from locations nationwide • Satisfaction guaranteed

The racing world comes to Summit Racing Equipment because Summit Racing has it all. That means the best parts from the top manufacturers—in stock and ready to ship today! Those parts are backed by expert technical advice from the industry's largest full-time technical department and the best customer service around.

NHRA Members, We're Your Go-Fast Source!

Shop anytime. Use the Summit Racing Mobile App to browse thousands of parts, add items to your cart, check your order status, create wish lists, read and post reviews, access Summit Racing's social media channels, and more.



The World's Speed Shop[®]



Follow us:



1-800-230-3030

