



USER INSTRUCTIONS

DYNA 4000 PRO HIGH ENERGY IGNITION SYSTEM FOR HARLEY-DAVIDSON ENGINES

(QUAD OUTPUT MODEL DP 4000-HD2, FOR DUAL PLUGGED HEADS)

This ignition is a quad output model for use with dual plugged heads. This DP 4000-HD2 ignition module may also be used with single plugged heads if the extra two coil outputs are simply not connected to anything. If you intend to use this module with single plugged heads, refer to the single plug system wiring diagrams and installation instructions included with the DP 4000-HD1 dual output ignition module.

DESCRIPTION

The DYNA 4000 Pro Ignition is a high energy inductive ignition designed to meet the needs of the professional drag racer. The DYNA 4000 includes a built-in two stage rev limiter that is used for launch control and over rev protection.

The DYNA 4000 ignition represents a significant enhancement in the ignition performance available to the serious racer. Traditionally the two types of ignitions available, inductive and capacitive discharge, both have limitations in the racing environment. Inductive ignitions have the benefit of a very long spark duration, but the disadvantage that they can't fully charge the coil at high rpm due to slow charging coils. Capacitive discharge (CD) ignitions can work at high rpm, but can't deliver much spark energy and have a very short spark duration (about 1/5 the spark duration of an inductive system).

The answer!

The best ignition imaginable would have a long spark duration and deliver high spark energy even at very high rpm. This is exactly what the DYNA 4000 has been designed to accomplish. By using specially designed coils, and special microprocessor based control circuitry to manage the high currents that these coils draw, the DYNA 4000 can deliver four times the spark energy of the most popular CD booster all the way up to 17,000 rpm! These high energy sparks also have the desirable long duration characteristics of inductive ignitions. This translates directly into better engine performance across the board.

The DYNA 4000 is not only a powerful ignition system, but also the smoothest two stage rev limiter available. The DYNA 4000 has a programmable launch limiter activated by a clutch switch to help maintain consistency at the starting line. A programmable over rev limiter is also implemented to prevent engine damage due to drive line breakage or missed shifts. The DYNA 4000 launch system is the choice of world champion drag racers due to its rock steady limiting characteristics. Other popular launch limiters cause engine harming banging and popping due to their unsteady limiting. The DYNA 4000 holds the rpm to a perfectly steady and smooth limit while preparing to launch.

INSTALLATION

****IMPORTANT**** With any microprocessor based engine system, such as the DYNA 4000, you must use carbon core type suppression spark plug wires with a resistance of at least 3000 ohms per foot to reduce radio frequency interference caused by ignition sparks. Use of copper or spiral core wires may cause malfunction of this ignition system due to severe electrical noise.

****** The DYNA 4000-HD2 Pro ignition uses the popular DYNA S, DS6-2 (single fire, w/two power modules) ignition as a pickup signal source. The DYNA S must be fitted with the special two magnet rotor included with this kit for the DYNA 4000 to function. The DYNA 4000 Pro can be wired in either single fire mode or dual fire mode (you need a DS6-2, single fire DYNA S as a pickup regardless of mode used).

****** The DYNA 4000 must be used with DYNATEK #DC9-1, 0.7 ohm, blue ignition coils. The DYNA 4000 will not work properly with other coils.

SINGLE FIRE/DUAL FIRE CONSIDERATIONS

A Harley ignition can take two basic forms, dual fire or single fire. In a dual fire system with dual plugged heads, two dual output ignition coils are used. The outputs of one coil are connected to spark plugs of both cylinders. In dual fire mode, each ignition coil always fires into both cylinders at the same time. At the time a spark is made one cylinder is under compression with a fresh air/fuel mixture and the other cylinder is in its exhaust stroke. Very high voltage is required to jump the gap of the spark plug under compression and fairly low voltage is required to jump the gap of the spark plug in the exhaust stroke on the other cylinder. The result of this difference in gap voltages of the spark plugs connected to one coil is that most of the available ignition energy is delivered to the plug under compression. In other words, in a dual fire system, the cylinder that needs its fuel ignited gets the majority of the energy that has been stored in the coil even though the coil is connected to both cylinders. Now, with dual plugged heads and a dual fire ignition, you have two coils hooked to both cylinders. Again the plugs under compression get most of the ignition energy. Since two coils are used, when the spark plugs are fired, the cylinder under compression receives two coils worth of energy to ignite the fuel.

In single fire mode one coil is connected to the plug(s) of one cylinder only. Each cylinder receives sparks independently and only at the firing point in the compression stroke. On street engines with dual plugged heads, a common way to set up a single fire ignition is to take two dual output coils, and connect both outputs of a single coil to the spark plugs of a single cylinder. This works with low compression engines. For racing there are two inherent problems with this setup. First, only one coil worth of energy is delivered to the fuel mixture at the firing point since only one coil is connected to a cylinder, unlike the dual fire setup discussed above where two coils worth of energy is delivered to the compressed cylinder. Secondly, the ignition coil must generate twice the usual firing voltage to get across two spark plug gaps under compression at the same time. This can cause internal arcing in the coil which can degrade ignition performance and eventually cause coil failure. The solution to the single fire, dual plugged head problem is to use four ignition coils. One coil driving each spark plug. Using one coil per spark plug allows you to have a true single fire ignition and deliver two coils worth of energy to the cylinder at the firing point. This setup also puts a reasonable load on the coils that will not degrade their performance. In order to accomplish this setup you need a quad (four) output ignition that can drive the four ignition coils such as the DYNA DP 4000-HD2 ignition.

COILS

For single fire w/dual plugged heads you need four DC9-1 coils; for dual fire w/dual plugged heads you need two DC9-1 coils.

1. Choose a mounting place for the DYNA 4000 that is well away from the ignition coils and spark plug wires. The coils are a source of intense magnetic interference which can cause erratic operation of sensitive electronics. The most common ignition placement is under the seat near the rear tire.

For dual fire installation skip down to step DF 2 ('DUAL FIRE INSTALLATION').

SINGLE FIRE INSTALLATION (separate coil for each spark plug)

SF 2. Mount the four DC9-1 coils close to the spark plugs to minimize spark plug wire length. Assign one coil to each spark plug. Connect carbon core spark plug wires from one of the output towers of each coil to the appropriate spark plug.

Locate the 6 inch coil tower grounding wires included with your kit. Plug a tower grounding wire into the second (unused) coil output on each coil and attach the other end of the wire to chassis ground (usually attached to the coil mounting bracket) (see wiring diagram).

***Refer to the included system wiring diagram during the following steps

SF 3. Find the main extension harness in your kit (the one with the six pin connector). Position the six pin connector in the area where you will be mounting the DYNA 4000. This harness has six 16 gauge wires: red, black, blue, white, purple and yellow. Route these wires to the coil area. It is best to route the blue, white, purple and yellow wires away from the red and black wires. For instance, run the blue, white, purple and yellow wires down one side of the frame backbone and the red and black wires down the other side of the frame backbone. This will help to isolate the high voltage pulses found in the blue, white, purple and yellow wires from the rest of the system. (Other wiring on the vehicle should also be kept away from the blue, white, purple and yellow wires)

Connect the 16 gauge white wire to one of the primary terminals on one coil assigned to the rear cylinder. Connect the 16 gauge yellow wire to one of the primary terminals on the other coil assigned to the rear cylinder. Connect the 16 gauge blue wire to one of the primary terminals on one coil assigned to the front cylinder. Connect the 16 gauge purple wire to one of the primary terminals on the other coil assigned to the front cylinder. (On a dual output coil it doesn't matter which primary terminal you attach the ignition wire to, there is no polarity to the coil primary terminals)

SF 4. You may need some additional 16 gauge red wire to complete this step. Attach a length of 16 gauge wire to the unused primary terminal of each coil. This will be the +12V supply to each coil. Connect these four wires together along with the 16 gauge red wire from the DYNA 4000. This joint should be made well, preferably with solder, to insure a good connection. Route a heavy gauge, (at least 14 gauge) wire from your ignition switch to this junction of these wires to supply +12V to the coils and DYNA 4000. A four coil system can draw more than 10 amps of current at high rpm, so it is very important to have large gauge power wires from the battery, through the ignition and kill switches and to the coils and ignition. Some kill switches and ignition switches have small gauge wires permanently attached to them, if you have one of these - replace it! By far the most common cause of electrical problems on race bikes is poor power distribution through inadequate or faulty switches or through the use of wire that is too small to handle the required current. (After you finish your installation check the supply voltage at the coil +12V terminals with the engine running at mid rpm. If there is more than a one volt drop from the battery +12V terminal to the coil +12V terminal with the engine running you need to improve your power wiring to the coils and ignition system.)

To continue single fire installation skip to 'SINGLE OR DUAL FIRE CONTINUED' below.

DUAL FIRE INSTALLATION (each coil feeds both cylinders)

DF 2. Mount the DC9-1 coils close to the spark plugs to minimize spark plug wire length. Connect carbon core spark plug wires from the output towers of each coil to the spark plugs of both cylinders.

***Refer to the included system wiring diagram during the following steps

DF 3. Find the main extension harness in your kit (the one with the six pin connector). Position the six pin connector in the area where you will be mounting the DYNA 4000. This harness has six 16 gauge wires: red, black, blue, white, purple and yellow. Route these wires to the coil area. It is best to route the blue, white, purple and yellow wires away from the red and black wires. For instance, run the blue, white, purple and yellow wires down one side of the frame backbone and the red and black wires down the other side of the frame backbone. This will help to isolate the high voltage pulses found in the blue, white, purple and yellow wires from the rest of the system. (Other wiring on the vehicle should also be kept away from the blue, white, purple and yellow wires)

Connect the 16 gauge white and blue wires to one of the primary terminals on one coil (connect them to the same terminal). Connect the 16 gauge purple and yellow wires to one of the primary terminals on the other coil (connect them to the same terminal).

DF 4. Locate the six inch 16 gauge red jumper wire included with your kit. Connect this jumper between the unused primary terminals on each coil. Connect +12V from the ignition switch to one end of the jumper at a coil. Connect the 16 gauge red wire from the DYNA 4000 to the same coil terminal that you connected the ignition switch wire to.

SINGLE OR DUAL FIRE CONTINUED

****IMPORTANT**** This is a +12V only system, do not connect +18V or other voltages to the ignition coils. More voltage will not produce more energy on this system, it will only cause overheating of the DYNA 4000 ignition module.

5. Connect the 16 gauge black wire from the DYNA 4000 to a good chassis ground point.

6. Locate the pickup extension harness. This harness contains four wires, red, black/wht, white, and blue on a four position connector. Route these wires separately from the main harness going to the coils for best electrical noise isolation. Route the DYNA 4000 pickup wires to the wires coming from your DYNA S ignition. Connect the DYNA 4000 pickup wires to the DYNA S wires as follows:

| <u>DYNA 4000 pickup wire</u> | <u>to</u> | <u>DYNA S wire</u> |
|------------------------------|-----------|----------------------------------|
| red | to | red |
| white | to | white |
| blue | to | black |
| black/wht | to | DYNA S base plate mounting screw |

Route the black/wht pickup wire from the DYNA 4000 down to the DYNA S ignition base plate and connect it to one of the base plate mounting screws using a ring terminal.

7. Install the special two magnet DYNA S rotor onto the camshaft. The extra magnet is located 90 degrees ahead of the normal firing magnet as seen by the pickups when the camshaft is rotating (the camshaft rotates counterclockwise).

8. After the main extension harness and pickup harness have been installed and the two magnet DYNA S rotor is in place and the 0.7 ohm coil(s) have been installed, you are ready to static time the motor. Plug the DYNA 4000 ignition module onto the six pin main harness connector and the four pin pickup connector. Apply +12V power to the DYNA 4000 by turning on the ignition switch. While slowly turning the engine in its normal forward direction with a wrench (camshaft turns counterclockwise), watch the red LED lamp located on top of the DYNA 4000. When either magnet of the DYNA S pickup rotor passes in front of one of the DYNA S modules, the red LED will light. This indicates the switching action of the pickup. When the crankshaft is turned in its normal forward direction, the first magnet to pass the DYNA S module is the 90 degree lead magnet. Do not static time off this magnet. Static timing must be checked when the second magnet comes near the DYNA S, at the point where the LED comes on. The crankshaft timing marks should be visible in the inspection hole on the flywheel side of the motor when the 2nd magnet passes the front cylinder (larger) module of the DYNA S.

9. You should be able to start the motor at this point. If the motor will not start, check that you are getting +12V from the ignition switch to the coil(s) and to the DYNA 4000 and check all other wiring.

10. In order to use the two stage rev limiter, complete the following: Locate the red and black two wire extension harness in your kit. Connect the two pin connector on the harness to the mating two pin connector on the DYNA 4000 ignition module. The red and black wires should be routed to the clutch switch on the handle bar. Again it is best to route these wires on the opposite side of the frame as the blue, white, purple and yellow coil wires to minimize electrical noise in the clutch switch circuitry. Connect the red and black wires to either side of the clutch switch. When the clutch switch is closed (lever pulled in) the DYNA 4000 low side rev limiter will be active. When the clutch switch is open (lever released) the high side rev limiter will be active. If you do not connect these wires to anything, the high side limiter will always be active.

11. If you wish to use an air kill switch to interrupt the ignition during shifts, complete the following: Locate the orange and black two wire extension harness included with your kit. Connect the two pin connector on the harness to the mating connector on the DYNA 4000 ignition module. The orange and black wires should be connected to either side of the air kill switch. Use the switch contacts that are normally open. When the switch contacts close, connecting the black and orange wires, the ignition will be interrupted. No other wires should be connected to the air kill switch. Do not run +12v ignition power through the air kill switch as you would with other systems.

12. Tach out wire. The green tach output wire extending from the DYNA 4000 ignition module can be used to directly drive an electronic tachometer or other crank speed sensing device, such as a DYNA Shiftminder or DYNA Datalog computer.

USING YOUR DYNA 4000 SYSTEM

You should have your system completely installed at this point, and the motor timed and ready to run. Locate the two white knobs on the end of the DYNA 4000 ignition module. These are used to set the rev limiters. Adjust the left knob according to the legend to set the low side launch limit to the desired rpm. Adjust the right knob according to the legend to set the high side over rev limit. Both rev limiters are adjustable in 250 rpm increments.

The DYNA 4000 reads the settings of the rpm limit switches only when the unit is first turned on. In other words, if you make an adjustment to one of the rev limit switch settings while the ignition power is on, you must turn off power to the DYNA 4000 then reapply power for the new switch settings to be recognized.

When you have the clutch lever pulled in you should be able to rev the motor up to the preset low side limit and slowly roll the throttle wide open. The limiter should hold the motor to the desired rpm until the clutch lever is released, then the high side limit will take over.

DYNA 4000-HD PRO, QUAD WIRING, DUAL FIRE W/DUAL PLUG

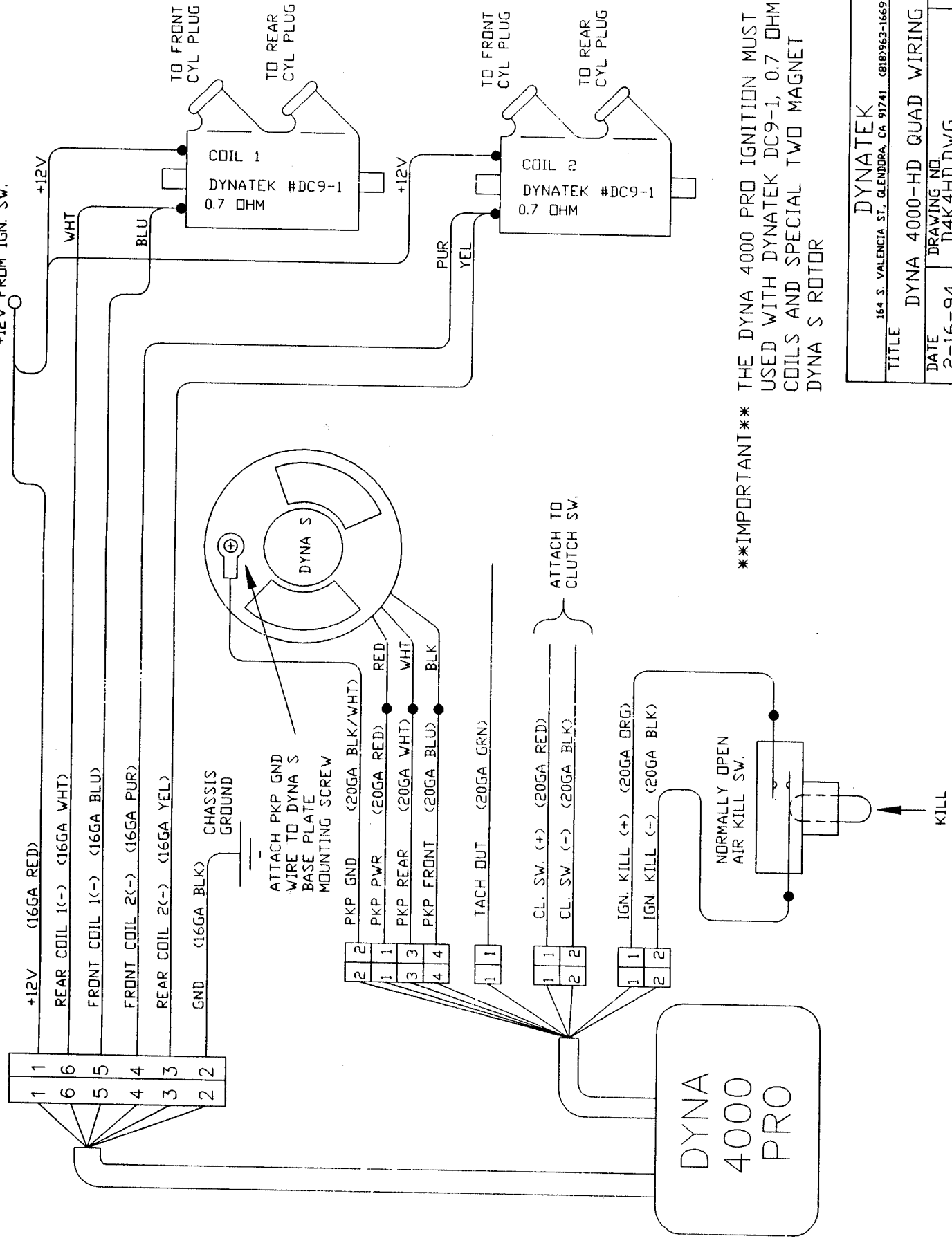

****IMPORTANT**** THE DYNA 4000 PRO IGNITION MUST BE USED WITH DYNATEK DC9-1, 0.7 OHM COILS AND SPECIAL TWD MAGNET DYNA S ROTOR

| | |
|--|--------------------------|
| DYNATEK 164 S. VALENCIA ST., GLENDORA, CA 91741 (818)963-1669 | |
| TITLE | DYNA 4000-HD QUAD WIRING |
| DATE | 2-16-94 |
| DRAWING NO. | D4K4HD.DWG |
| REV | 2.0 |

DYNA 4000 PRO - QUAD SYSTEM COIL WIRING HARLEY DUAL PLUG, SINGLE FIRE

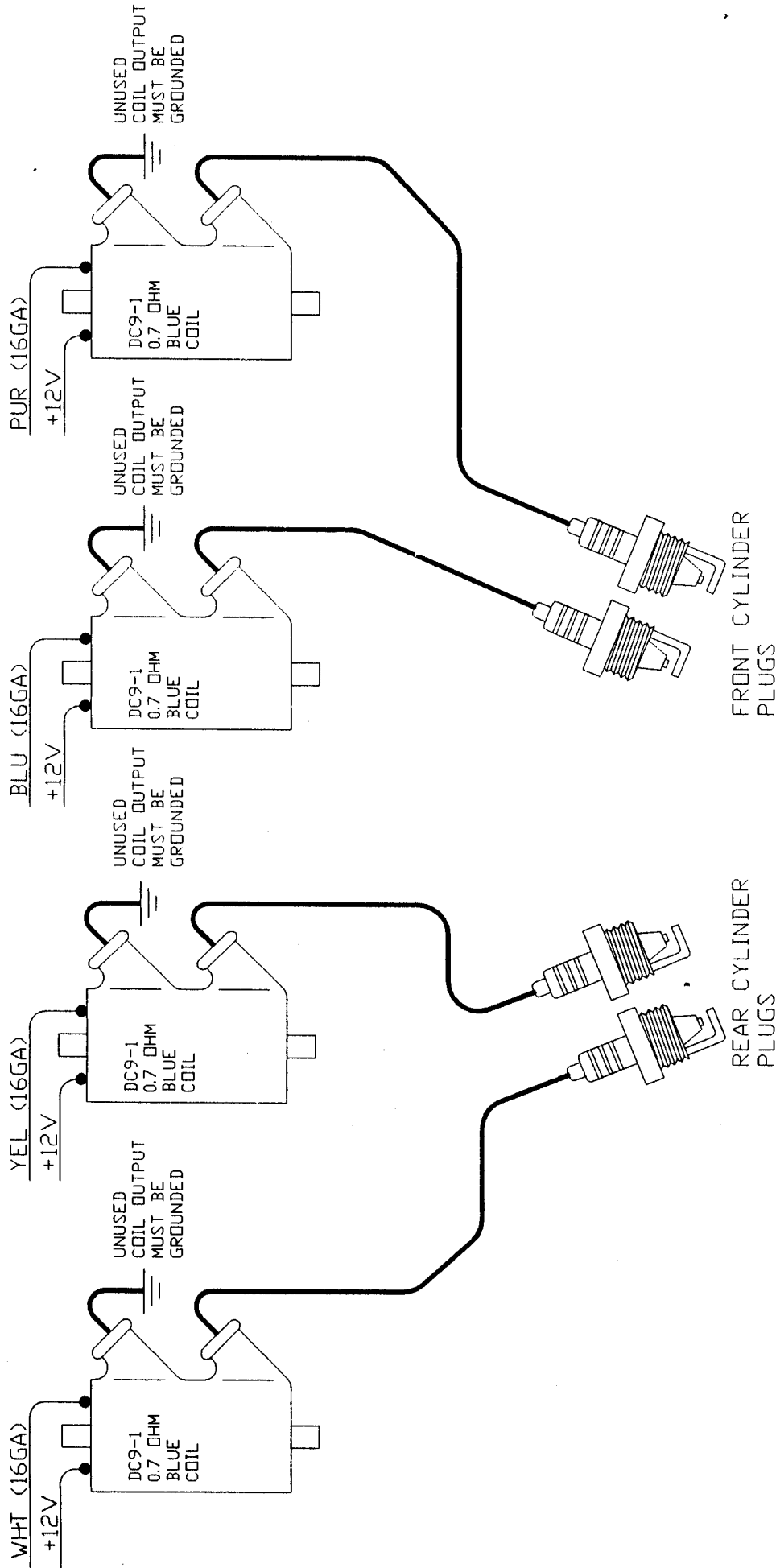

IMPORTANT
USE ONLY CARBON CORE SPARK PLUG
WIRES WITH RESISTANCE OF AT
LEAST 3000 OHMS PER FOOT

| | |
|---|----------------------------|
| DYNATEK | |
| 164 S. VALENCIA ST, GLENDBRA, CA 91741 (818) 963-1669 | |
| TITLE | DYNA 4000 QUAD COIL WIRING |
| DATE | 2-15-94 |
| DRAWING NO. | D4KHD4CL.DWG |
| REV | 2.0 |

DYNA 4000-HD PRO, QUAD WIRING, SINGLE FIRE W/DUAL PLUG

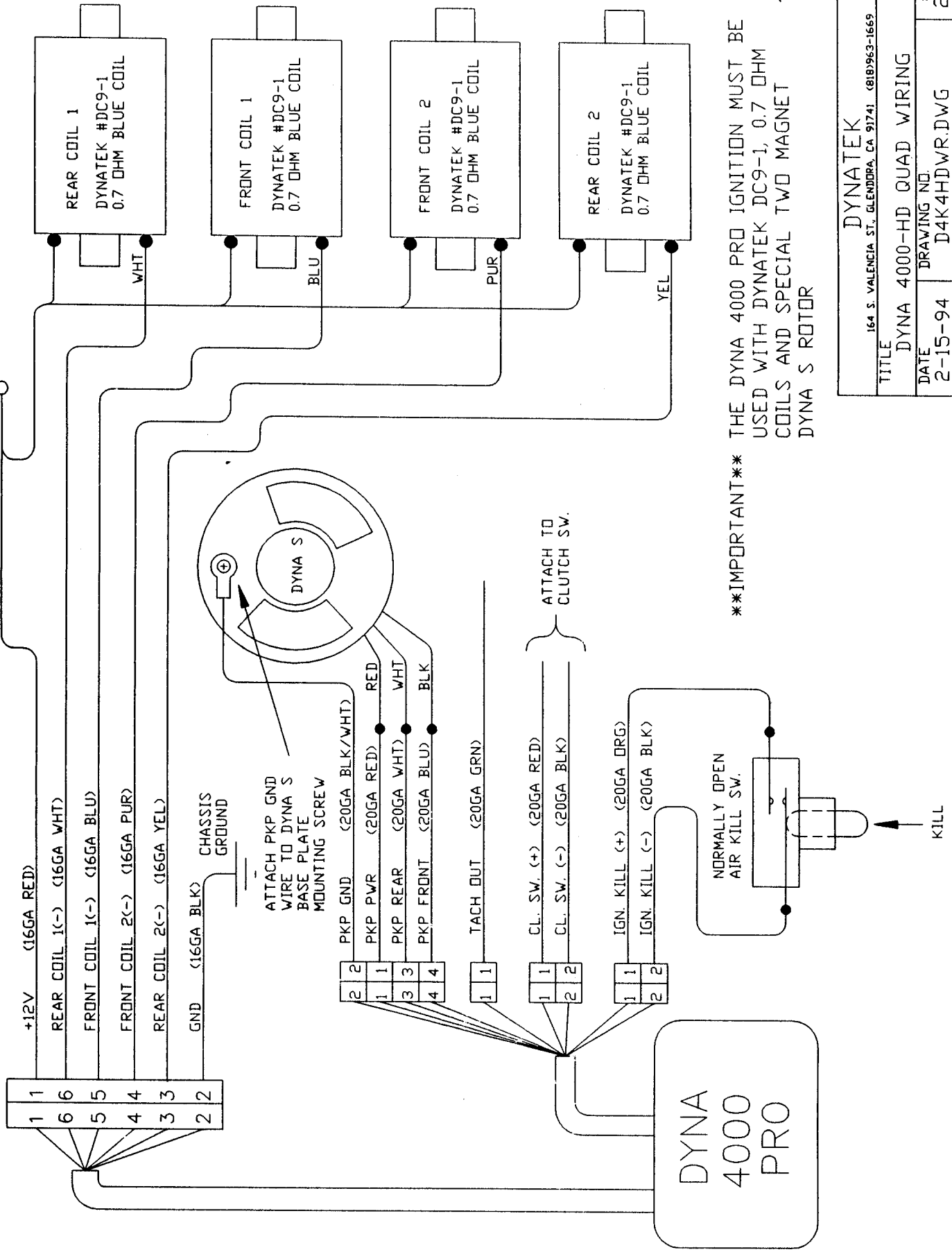

****IMPORTANT**** THE DYNA 4000 PRO IGNITION MUST BE USED WITH DYNATEK DC9-1, 0.7 OHM COILS AND SPECIAL TWD MAGNET DYNA S ROTOR

| | |
|---|-----------------------------|
| DYNATEK | |
| 164 S. VALENCIA ST., GLENDDRA, CA 91741 (818)963-1669 | |
| TITLE DYNA 4000-HD QUAD WIRING | |
| DATE 2-15-94 | DRAWING NO. D4K4HDWR.DWG |
| REV 2.0 | |